

Appendices

Appendix A – Lubbethorpe Off Site Junction Improvements Plan

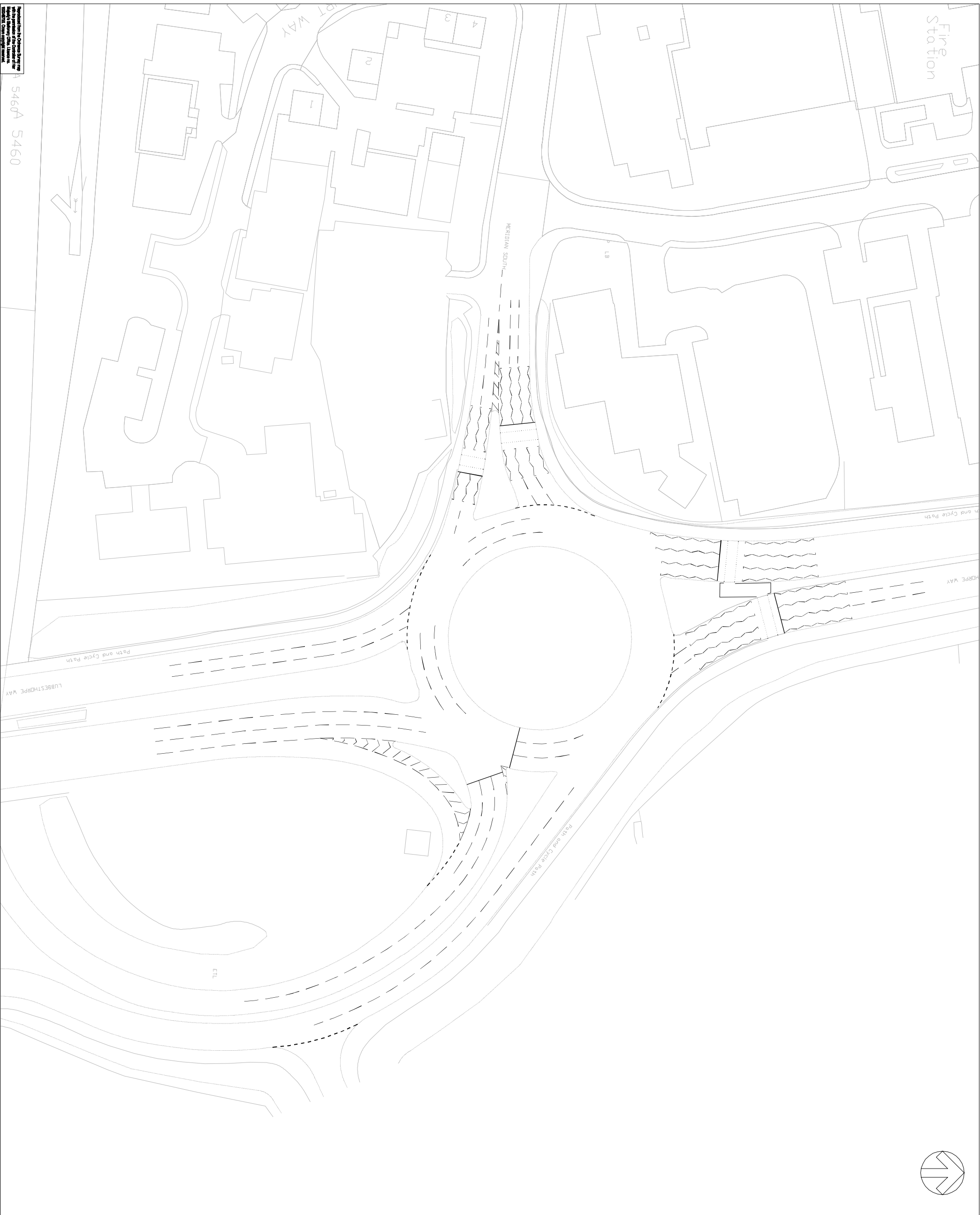

DO NOT SCALE

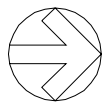

5460A 5460

<p>DATE: 26-08-12 REV: 01 DATE: 01-09-12</p>		<p>REV: 01 DATE: 01-09-12</p>		<p>DESCRIPTION: MERIDIAN SOUTH</p>		<p>ISS: 01 CHK: ALN APP: ALN</p>	
<p>DRAWING STATUS: FOR INFORMATION ONLY</p>							
<p>CLIENT: HLM, BARRATT HOMES & DAVIDSON DEVELOPMENTS</p>							
<p>PROJECT: NEW LOBBESTHORPE, LEICESTER</p>							
<p>PROJ: FPCR</p>							
<p>SCALE: 1:500</p>							
<p>DATE: 1693-GA-01 MERIDIAN SOUTH</p>							
<p>PROJECT NO: 11501693</p>							
<p>DATE: August 2012</p>							
<p>PROJECT NO: 1693-GA-01</p>							
<p>REV: A</p>							



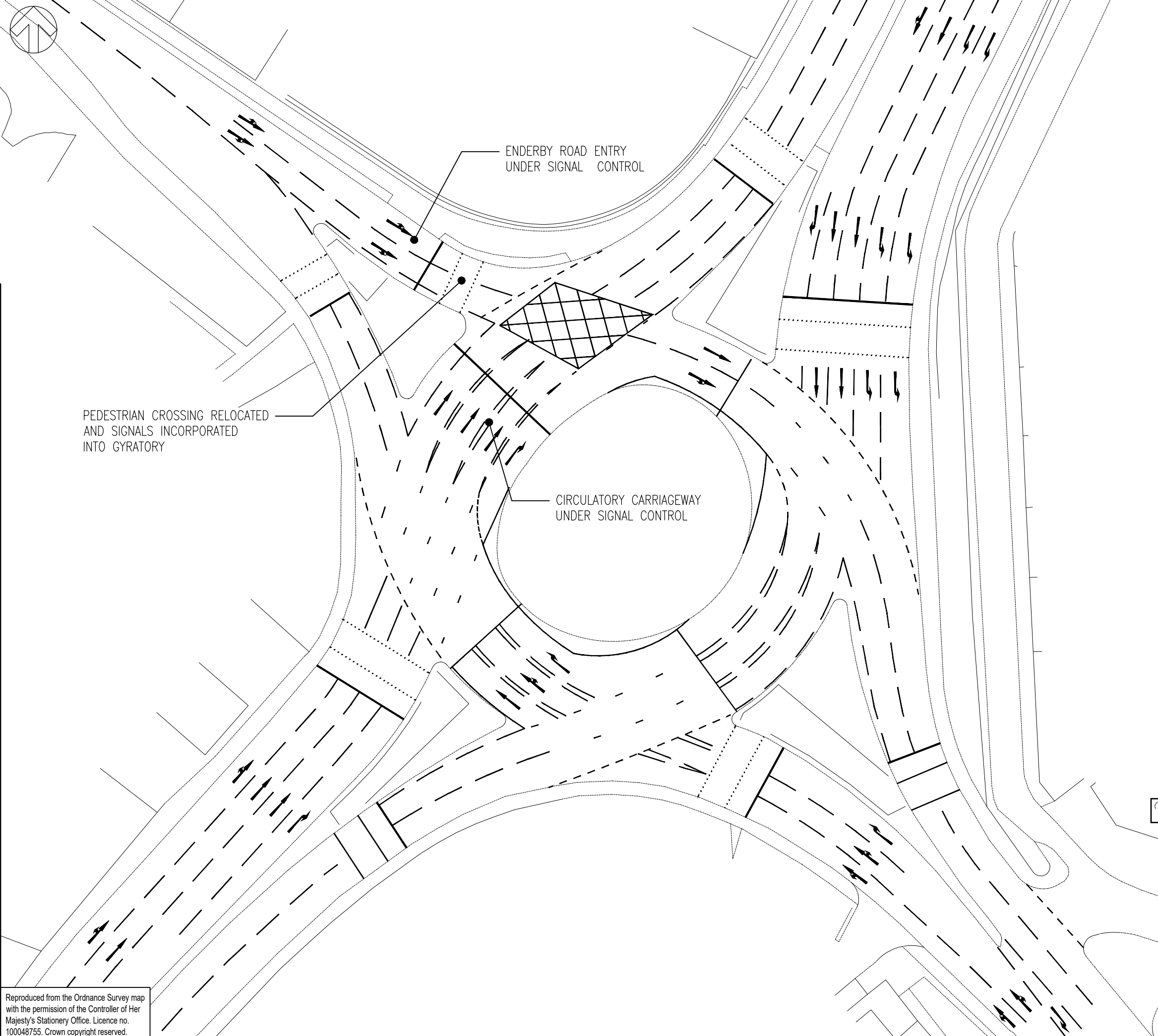

ENDERBY ROAD ENTRY
UNDER SIGNAL CONTROL

PEDESTRIAN CROSSING RELOCATED
AND SIGNALS INCORPORATED
INTO GYRATORY

CIRCULATORY CARRIAGEWAY
UNDER SIGNAL CONTROL

DO NOT SCALE

A	16/03/2012	DMG	FIRST ISSUE		DMG	BP
REV	DATE	BY	DESCRIPTION	CHK	APD	

DRAWING STATUS: FOR INFORMATION ONLY



Unit 9, The Chase, John Tate Road
Foxholes Business Park, Hertford SG13 7NN
Tel: +44 (0)1992 526000 Fax: +44 (0)1992 526001
<http://www.wspgroup.com>

CLIENT:
HLM, BARRATT HOMES & DAVIDSON DEVELOPMENTS

ARCHITECT:
FPCR

PROJECT:
LEICESTER, NEW LUBBESTHORPE

TITLE:
B582/B4114 FOXHUNTER ROUNDABOUT
PROPOSED SIGNALISATION OF
ENDERBY ROAD

SCALE @ A3: 1:500 CHECKED: DMG APPROVED: BP

CAD FILE: 1693-P-25 DESIGN-DRAWN: DMG DATE: September 2013

PROJECT No: 11501693 DRAWING No: 1693-P-25 REV: A

© WSP Group plc

P:\11501693\11501693_P-25\11501693_P-25.dwg 16/03/2012 11:58:59 AM DMG

Reproduced from the Ordnance Survey map with the permission of the Controller of Her Majesty's Stationery Office. Licence no. 100048755. Crown copyright reserved.

NOTES
 1. This drawing has been prepared in accordance with the scope of RPS's appointment with its client and is subject to the terms and conditions of that appointment. RPS accepts no liability for any use of this document other than by its client and only for the purposes for which it was prepared and provided.
 2. If received electronically it is the recipient's responsibility to print to correct scale. Only written dimensions should be used. DO NOT SCALE.

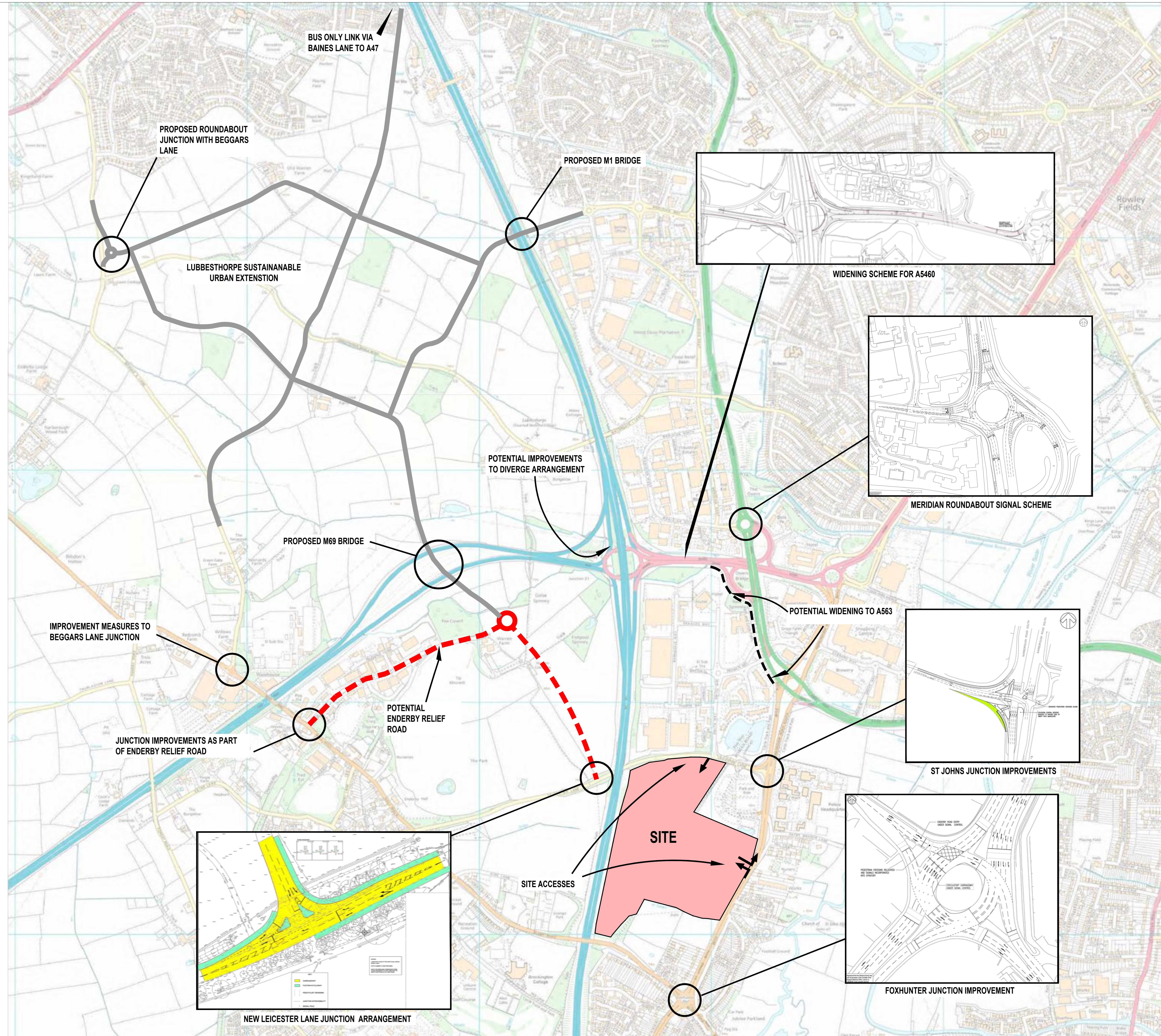

Rev	Description	Date	Initial	Checked

RPS
 140 London Wall
 London, EC2Y 5DU
 T: +44(0)20 7300 3300 E: transport@rpsgroup.com

Client **DRUMMOND ESTATE**
 Project **ENDERBY, BLABY**

Title **PROPOSED MEASURES TO BE IMPLEMENTED BY NEW LUBBESTHORPE SCHEME & BY PROPOSED B8 DEVELOPMENT**

Status **MRA** Drawn By **BRP** Checked by **BRP**
 Project Number **JNY8838** Scale **@ A0** Date Created **25/08/2016**
 NTS

Drawing Number **JNY8838/14** Rev

© Crown Copyright. All rights reserved. RPS Group Licence Number 1000000000

Appendix B – Accident Data

Year 2017

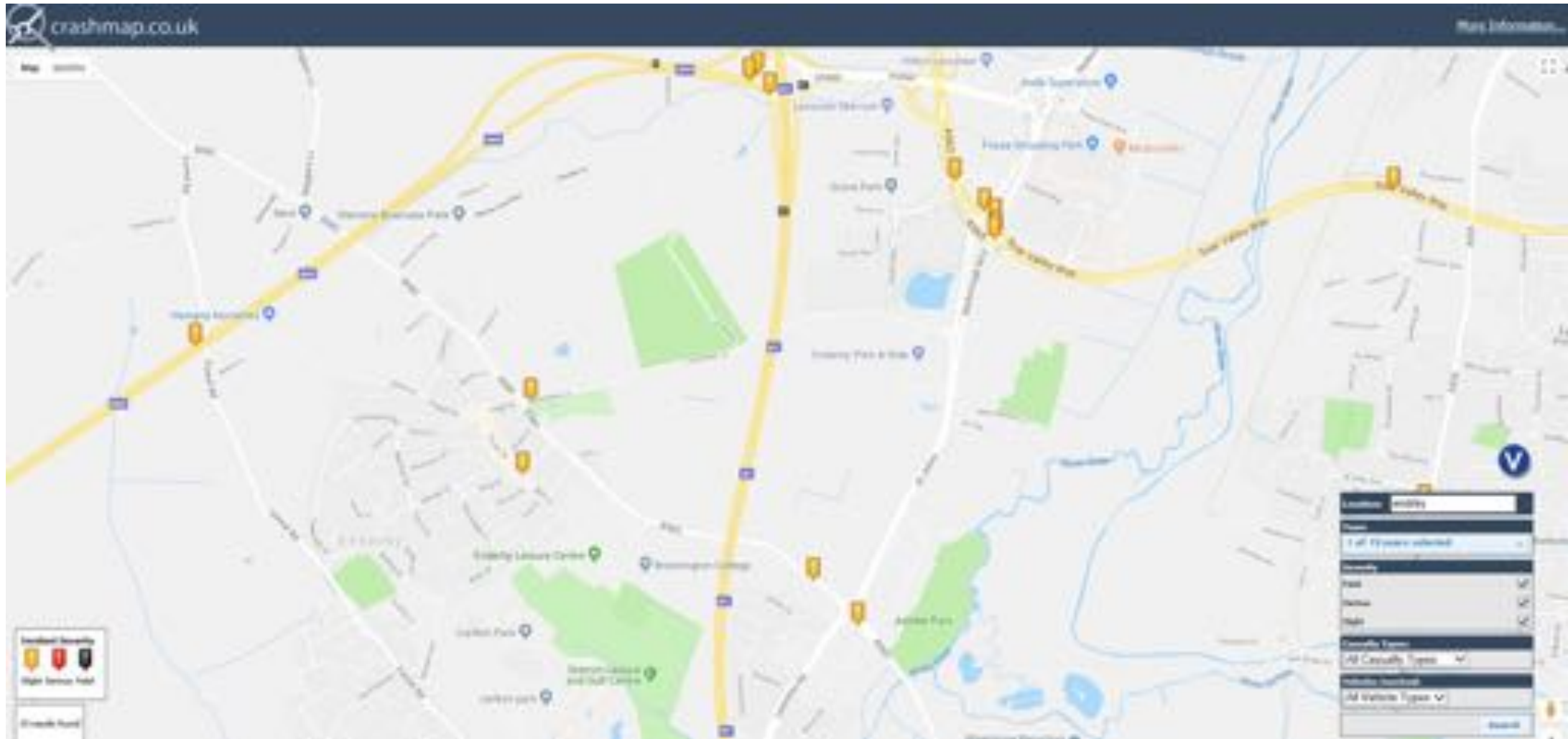

Accidents between dates 01/01/2011 and 02/09/2016 (68) months

Selection: Notes:

; Refined using Accidents within selected Polygons -Data request polygons ("RPS Enderby 15.09.2016")

Selected Polygon:RPS Enderby 15.09.2016

201100354 19/01/2011 Wednesday Time 1230 Vehicles 2 Casualties 1 Slight
 Fine without high winds Road surface Wet/Damp Daylight:
 Special Conditions None Road Type Dual carriageway
 V2 TRAV N ST JOHNS COLLS REAR V1 STATIONARY AHEAD HELD AT TRAFFIC LIGHTS.
 Occurred on B4114 ST JOHNS ENDERBY JW LEICESTER LANE.

Vehicle Reference 1 Car Waiting to go ahead but held up
 Not in restricted lane No skidding, jack-knifing or overturning
 First point of impact Back Age of Driver 30 Breath test Not requested
 Vehicle direction S to N
 FRV Journey 6
 Casualty Reference: 1 Age: 30 Female Driver/rider Severity: Slight

Vehicle Reference 2 Car Going ahead
 Not in restricted lane No skidding, jack-knifing or overturning
 First point of impact Front Age of Driver 38 Breath test Not requested
 Vehicle direction S to N
 FRV Journey 6

201100367 19/01/2011 Wednesday Time 1605 Vehicles 2 Casualties 3 Slight
 Fine without high winds Road surface Dry Daylight:
 Special Conditions None Road Type Roundabout
 V2 TRAV N/W SOAR VALLEY WAY TURNING R TRAV N/E COLLS O/S V1 TRAV N/E N/R/S ON R/ABOUT. UNKNOWN WHICH PARTY DISOBEYED TRAFFIC LIGHTS.
 Occurred on B4114 NARBOROUGH ROAD SOUTH ENDERBY ROUNDABOUT JW SOAR VALLEY WAY.

Vehicle Reference 1 Car Going ahead
 Not in restricted lane No skidding, jack-knifing or overturning
 First point of impact Front Age of Driver 36 Breath test Negative
 Vehicle direction S to NE
 FRV Journey 6
 Casualty Reference: 1 Age: 36 Female Driver/rider Severity: Slight

Casualty Reference: 2 Age: 48 Female Passenger Severity: Slight

Vehicle Reference 2 Car Turning right
 Not in restricted lane No skidding, jack-knifing or overturning
 First point of impact Nearside Age of Driver 60 Breath test Negative
 Vehicle direction SE to NE
 FRV Journey 6
 Casualty Reference: 3 Age: 60 Female Driver/rider Severity: Slight

Accidents between dates 01/01/2011 and 02/09/2016 (68) months

Selection:

; Refined using Accidents within selected Polygons -Data request polygons ("RPS Enderby 15.09.2016")

Notes:

201100574 27/01/2011 Thursday Time 0742 Vehicles 2 Casualties 1 Slight
Fine without high winds Road surface Dry Daylight:
Special Conditions None Road Type Single carriageway
V1 REVERSING TRAV S/W ST JOHNS COLLS REAR V2 (CYCLE) TRAV UNKNOWN DIRECTION ST JOHNS.
Occurred on ST JOHNS ENDERBY JW TRINITY ROAD

Vehicle Reference	1	Car				Reversing
Not in restricted lane						No skidding, jack-knifing or overturning
First point of impact	Back		Age of Driver	44	Breath test	Negative
Vehicle direction	NW to SW					
FRV					Journey	Journey as part of work
Vehicle Reference	2	Pedal cycle				Slowing or Stopping
Not in restricted lane						No skidding, jack-knifing or overturning
First point of impact	Back		Age of Driver	37	Breath test	Not applicable
Vehicle direction	SE to NW					
FRV					Journey	Journey as part of work
Casualty Reference:	1	Age:	37	Male	Driver/rider	Severity: Slight

201100850 11/02/2011 Friday Time 0925 Vehicles 2 Casualties 2 Slight
Fine without high winds Road surface Dry Daylight:
Special Conditions None Road Type Roundabout
V1 TRAV N/W SOAR VALLEY WAY POSSIBLY DISOBEYED RED TRAFFIC SIGNAL TRAV AHEAD ENTERING R/ABOUT & COLLS N/S V2 TRAV S/E NARBOROUGH RD SOUTH.
Occurred on B4114 NARBOROUGH ROAD ENDERBY ROUNDABOUT JW SOAR VALLEY WAY.

Vehicle Reference	1	Car				Going ahead
Not in restricted lane						No skidding, jack-knifing or overturning
First point of impact	Front		Age of Driver	25	Breath test	Negative
Vehicle direction	SE to NW					
FRV					Journey	6
Casualty Reference:	1	Age:	25	Male	Driver/rider	Severity: Slight
Vehicle Reference	2	Car				Going ahead
Not in restricted lane						No skidding, jack-knifing or overturning
First point of impact	Nearside		Age of Driver	21	Breath test	Not provided (medical)
Vehicle direction	NE to SW					
FRV					Journey	6
Casualty Reference:	2	Age:	21	Male	Driver/rider	Severity: Slight

Accidents between dates 01/01/2011 and 02/09/2016 (68) months

Selection: ; Refined using Accidents within selected Polygons -Data request polygons ("RPS Enderby 15.09.2016")

Notes:

201101135 23/02/2011 Wednesday Time 1825 Vehicles 2 Casualties 1 Slight
 Fine without high winds Road surface Dry Darkness: street lights present and lit
 Special Conditions None Road Type Dual carriageway
 V2 TRAV S/W NARBOROUGH RD SOUTH LANE 1 CHANGES LANES R & COLLS N/S V1 TRAV S/W LANE 2. V2 HIT & RUN.
 Occurred on B4114 NARBOROUGH ROAD SOUTH ENDERBY ROUNDABOUT JW LUBBESTHORPE WAY.

Vehicle Reference 1 Car Going ahead
 Not in restricted lane No skidding, jack-knifing or overturning
 First point of impact Nearside Age of Driver 22 Breath test Driver not contacted
 Vehicle direction NE to SW
 FRV Journey 6
 Casualty Reference: 1 Age: 22 Female Driver/rider Severity: Slight

Vehicle Reference 2 Car Changing lane to right
 Not in restricted lane No skidding, jack-knifing or overturning
 First point of impact Offside Age of Driver Breath test Driver not contacted
 Vehicle direction NE to SW
 FRV Journey 6

201101508 17/03/2011 Thursday Time 1519 Vehicles 2 Casualties 1 Slight
 Fine without high winds Road surface Dry Daylight:
 Special Conditions None Road Type Dual carriageway
 V2 & V1 TRAV N/W SOAR VALLEY WAY. V2 STOPS AT CHANGE OF TRAFFIC LIGHTS. V1 EXPECTING V2 TO PROCEED
 SLOWS BUT COLLS REAR V2.
 Occurred on A563 SOAR VALLEY WAY ENDERBY ROUNDABOUT JW NARBOROUGH ROAD SOUTH.

Vehicle Reference 1 Goods <= 3.5 tonnes mgw Slowing or Stopping
 Not in restricted lane No skidding, jack-knifing or overturning
 First point of impact Front Age of Driver 44 Breath test Negative
 Vehicle direction SE to NW
 FRV Journey 6
 Vehicle Reference 2 Car Waiting to go ahead but held up
 Not in restricted lane No skidding, jack-knifing or overturning
 First point of impact Back Age of Driver 29 Breath test Negative
 Vehicle direction SE to NW
 FRV Journey Journey as part of work
 Casualty Reference: 1 Age: 29 Male Driver/rider Severity: Slight

Accidents between dates 01/01/2011 and 02/09/2016 (68) months

Selection:

; Refined using Accidents within selected Polygons -Data request polygons ("RPS Enderby 15.09.2016")

Notes:

201102448 04/05/2011 Wednesday Time 1040 Vehicles 2 Casualties 1 Slight
Fine without high winds Road surface Dry Daylight:
Special Conditions None Road Type Roundabout
V1 TRAV S/E BLABY RD ENTERS ROUNDABOUT IN FRONT V2 TRAV N/E LEICESTER RD LEAVING ROUNDABOUT. V2 COLLS O/S V1.
Occurred on B4114 LEICESTER ROAD ENDERBY ROUNDABOUT JW BLABY ROAD.

Vehicle Reference 1 Car Going ahead
Not in restricted lane No skidding, jack-knifing or overturning
First point of impact Offside Age of Driver 73 Breath test Negative
Vehicle direction NW to SE
FRV Journey 6
Casualty Reference: 1 Age: 73 Female Driver/rider Severity: Slight

Vehicle Reference 2 Car Going ahead
Not in restricted lane No skidding, jack-knifing or overturning
First point of impact Front Age of Driver 26 Breath test Negative
Vehicle direction SW to NE
FRV Journey 6

201102596 12/05/2011 Thursday Time 1540 Vehicles 2 Casualties 1 Slight
Fine without high winds Road surface Dry Daylight:
Special Conditions None Road Type Single carriageway
V1 TRAV S/E BLABY RD TURNS R TRAV S/W LIME TREE RD & COLLS V2 (CYCLE) TRAV S/E CROSSING LIME TREE RD FROM FOOTWAY ON BLABY RD.
Occurred on LIME TREE ROAD ENDERBY JW BLABY ROAD.

Vehicle Reference 1 Car Turning right
Not in restricted lane No skidding, jack-knifing or overturning
First point of impact Front Age of Driver 40 Breath test Negative
Vehicle direction NW to SW
FRV Journey 6
Vehicle Reference 2 Pedal cycle Going ahead
Not in restricted lane No skidding, jack-knifing or overturning
First point of impact Front Age of Driver 40 Breath test Not applicable
Vehicle direction NW to SE
FRV Journey 6
Casualty Reference: 1 Age: 40 Male Driver/rider Severity: Slight

Accidents between dates 01/01/2011 and 02/09/2016 (68) months

Selection:

; Refined using Accidents within selected Polygons -Data request polygons ("RPS Enderby 15.09.2016")

Notes:

201102977 29/05/2011 Sunday Time 0830 Vehicles 3 Casualties 1 Slight

Fine without high winds Road surface Dry Daylight:

Special Conditions None Road Type Roundabout

V1 TRAV S/E LANE 1 ON R/ABOUT DISOBEYED RED TRAFFIC SIGNAL & COLLS V2 & V3 TRAV S/W LANE 3 & 2. ENTERING R/ABOUT. V1 LEAVES C/WAY AHEAD.

Occurred on B4114 NARBOROUGH ROAD SOUTH ROUNDABOUT JW SOAR VALLEY WAY.

Vehicle Reference 1 Car

Going ahead

Not in restricted lane

No skidding, jack-knifing or overturning

First point of impact Front

Age of Driver 32 Breath test Negative

Vehicle direction NW to SE

FRV

Journey 6

Vehicle Reference 2 Car

Going ahead

Not in restricted lane

No skidding, jack-knifing or overturning

First point of impact Offside

Age of Driver 32 Breath test Not provided (medical)

Vehicle direction NE to SW

FRV

Journey 6

Casualty Reference: 1 Age: 32 Male Driver/rider Severity: Slight

Vehicle Reference 3 Car

Going ahead

Not in restricted lane

No skidding, jack-knifing or overturning

First point of impact Offside

Age of Driver 68 Breath test Negative

Vehicle direction NE to SW

FRV

Journey 6

Accidents between dates 01/01/2011 and 02/09/2016 (68) months

Selection:

; Refined using Accidents within selected Polygons -Data request polygons ("RPS Enderby 15.09.2016")

Notes:

201103021 01/06/2011 Wednesday Time 2140 Vehicles 2 Casualties 2 Slight
 Fine without high winds Road surface Dry Darkness: street lights present and lit
 Special Conditions None Road Type Roundabout
 V1 TRAV S/E LUBBESTHORPE WAY ONTO SOAR VALLEY WAY & V2 TRAV S/W NARBOROUGH RD S COLLS MID JCT. V2 CLAIMED V1 DISOBEYED RED TRAFFIC LIGHT
 Occurred on B4114 NARBOROUGH ROAD SOUTH ENDERBY ROUNDABOUT JW SOAR VALLEY WAY.

Vehicle Reference	1	Car	Going ahead
Not in restricted lane			No skidding, jack-knifing or overturning
First point of impact	Nearside	Age of Driver	43
Vehicle direction	NW to SE	Breath test	Negative
FRV		Journey	6
Vehicle Reference	2	Car	Going ahead
Not in restricted lane			No skidding, jack-knifing or overturning
First point of impact	Front	Age of Driver	20
Vehicle direction	NE to SW	Breath test	Negative
FRV		Journey	6
Casualty Reference:	1	Age: 20	Male
			Passenger
			Severity: Slight
Casualty Reference:	2	Age: 19	Male
			Passenger
			Severity: Slight

201103222 10/06/2011 Friday Time 0715 Vehicles 2 Casualties 2 Slight
 Fine without high winds Road surface Dry Daylight:
 Special Conditions None Road Type Single carriageway
 V2 TRAV S/W ON SERVICE RD TURNS R TRAV N/W & COLLS V1 TRAV S/E BLABY RD. V1 & V2 LEAVES C/WAY O/S & N/S RESPECTIVELY.
 Occurred on B582 BLABY ROAD ENDERBY JW BLABY RD SERVICE ROAD TO HOUSES 252-260.

Vehicle Reference	1	Car	Going ahead
Not in restricted lane			No skidding, jack-knifing or overturning
First point of impact	Front	Age of Driver	35
Vehicle direction	NW to SE	Breath test	Negative
FRV		Journey	Journey as part of work
Casualty Reference:	1	Age: 35	Male
			Driver/rider
			Severity: Slight
Vehicle Reference	2	Car	Turning right
Not in restricted lane			No skidding, jack-knifing or overturning
First point of impact	Front	Age of Driver	67
Vehicle direction	NE to NW	Breath test	Negative
FRV		Journey	6
Casualty Reference:	2	Age: 67	Male
			Driver/rider
			Severity: Slight

Accidents between dates 01/01/2011 and 02/09/2016 (68) months

Selection:

; Refined using Accidents within selected Polygons -Data request polygons ("RPS Enderby 15.09.2016")

Notes:

201104577 16/08/2011 Tuesday Time 1705 Vehicles 2 Casualties 1 Serious
Fine without high winds Road surface Dry Daylight:
Special Conditions None Road Type Single carriageway
V1 TRAV S/W ON PRIVATE DRIVE MOVES OFF TO TURN L TRAV S/E MILL HILL & COLLS V2 (CYCLE) TRAV N/W LEAVING FOOTWAY TO CROSS PRIVATE DRIVE.
Occurred on B582 MILL HILL ENDERBY JW PRIVATE DRIVE TO BUILDING NO 57.

Vehicle Reference	1	Car	Moving off
Not in restricted lane			No skidding, jack-knifing or overturning
First point of impact	Front		Age of Driver 38 Breath test Driver not contacted
Vehicle direction	NE to SE		
FRV			Journey 6
Vehicle Reference	2	Pedal cycle	Going ahead
Not in restricted lane			No skidding, jack-knifing or overturning
First point of impact	Front		Age of Driver 56 Breath test Not applicable
Vehicle direction	SE to NW		
FRV			Journey Commuting to/from work
Casualty Reference:	1	Age: 56 Male	Driver/rider Severity: Serious

201104852 01/09/2011 Thursday Time 1710 Vehicles 2 Casualties 1 Slight
Fine without high winds Road surface Dry Daylight:
Special Conditions None Road Type Dual carriageway
V1 TRAV N/E PENMAN WAY FAILS TO STOP DUE TO CLAIMED BRAKE FAILURE & COLLS REAR V2 STATIONARY AHEAD HELD AT TRAFFIC LIGHTS.
Occurred on PENMAN WAY ENDERBY JW LUBBESTHORPE WAY.

Vehicle Reference	1	Car	Slowing or Stopping
Not in restricted lane			No skidding, jack-knifing or overturning
First point of impact	Front		Age of Driver 28 Breath test Negative
Vehicle direction	SW to NE		
FRV			Journey Commuting to/from work
Vehicle Reference	2	Car	Waiting to go ahead but held up
Not in restricted lane			No skidding, jack-knifing or overturning
First point of impact	Back		Age of Driver 30 Breath test Not provided (medical)
Vehicle direction	SW to NE		
FRV			Journey Commuting to/from work
Casualty Reference:	1	Age: 30 Female	Driver/rider Severity: Slight

Accidents between dates 01/01/2011 and 02/09/2016 (68) months

Selection:

; Refined using Accidents within selected Polygons -Data request polygons ("RPS Enderby 15.09.2016")

Notes:

201105262 20/09/2011 Tuesday Time 1102 Vehicles 3 Casualties 1 Slight
 Fine without high winds Road surface Dry Daylight:
 Special Conditions None Road Type Dual carriageway
 V1 (BUS) & UNKNOWN V3 TRAV N NARBOROUGH RD S BRAKE SUDDENLY FOR V2 (POLICE ON CALL) TURNING FROM HQ. V1 STANDING PASSENGER RECIEVES INJURY.
 Occurred on B4114 NARBOROUGH ROAD SOUTH ENDERBY JW PRIVATE ENTRANCE TO POLICE HQ.

Vehicle Reference 1 Bus or coach Slowing or Stopping
 Not in restricted lane No skidding, jack-knifing or overturning
 First point of impact Did not impact Age of Driver 64 Breath test Driver not contacted
 Vehicle direction S to N
 FRV Journey Journey as part of work
 Casualty Reference: 1 Age: 75 Female Passenger Severity: Slight

Vehicle Reference 2 Car Turning right
 Not in restricted lane No skidding, jack-knifing or overturning
 First point of impact Did not impact Age of Driver Breath test Driver not contacted
 Vehicle direction E to N
 FRV Journey Journey as part of work

Vehicle Reference 3 Car Slowing or Stopping
 Not in restricted lane No skidding, jack-knifing or overturning
 First point of impact Did not impact Age of Driver Breath test Driver not contacted
 Vehicle direction S to N
 FRV Journey 6

201105678 29/09/2011 Thursday Time 1645 Vehicles 2 Casualties 1 Slight
 Fine without high winds Road surface Dry Daylight:
 Special Conditions None Road Type Dual carriageway
 V1 & V2 TRAV S/W IN SLOW MOVING TRAFFIC. V2 SLOWS BUT COLLS REAR V1 ALREADY STATIONARY AHEAD.
 Occurred on B4114 ST JOHNS ENDERBY. EXACT LOCATION UNKNOWN.

Vehicle Reference 1 Car Waiting to go ahead but held up
 Not in restricted lane No skidding, jack-knifing or overturning
 First point of impact Back Age of Driver 28 Breath test Driver not contacted
 Vehicle direction NE to SW
 FRV Journey 6
 Casualty Reference: 1 Age: 28 Female Driver/rider Severity: Slight

Vehicle Reference 2 Car Slowing or Stopping
 Not in restricted lane No skidding, jack-knifing or overturning
 First point of impact Front Age of Driver Breath test Driver not contacted
 Vehicle direction NE to SW
 FRV Journey 6

Accidents between dates 01/01/2011 and 02/09/2016 (68) months

Selection:

; Refined using Accidents within selected Polygons -Data request polygons ("RPS Enderby 15.09.2016")

Notes:

201105822 14/10/2011 Friday Time 2135 Vehicles 2 Casualties 1 Slight
Fine without high winds Road surface Dry Darkness: street lights present and lit
Special Conditions None Road Type Roundabout
V1 TRAV TRAV S/W LANE 2 NARBOROUGH RD SOUTH & V2 TRAV N/W LANE 2 SOAR VALLEY WAY COLL MID JCT.
UNKNOWN WHICH VEH DISOBEYED TRAFFIC SIGNAL.
Occurred on B4114 NARBOROUGH ROAD SOUTH ENDERBY ROUNDABOUT JW SOAR VALLEY WAY.

Vehicle Reference 1 Car Going ahead
Not in restricted lane No skidding, jack-knifing or overturning
First point of impact Nearside Age of Driver 32 Breath test Negative
Vehicle direction NE to SW
FRV Journey 6
Casualty Reference: 1 Age: 32 Female Driver/rider Severity: Slight

Vehicle Reference 2 Car Going ahead
Not in restricted lane No skidding, jack-knifing or overturning
First point of impact Offside Age of Driver 45 Breath test Negative
Vehicle direction SE to NW
FRV Journey 6

201105944 24/10/2011 Monday Time 1530 Vehicles 2 Casualties 1 Slight
Fine without high winds Road surface Dry Daylight:
Special Conditions None Road Type Dual carriageway
V2 TRAV N/E PENMAN WAY TURNS R TO TRAV S/E & V1 TRAV N/W LUBBESTHORPE WAY COLLIDE MID JCT. UNKNOWN
WHICH PARTY DISOBEYED TRAFFIC SIGNAL.
Occurred on A563 LUBBESTHORPE WAY ENDERBY JW PENMAN WAY.

Vehicle Reference 1 Car Going ahead
Not in restricted lane No skidding, jack-knifing or overturning
First point of impact Front Age of Driver 21 Breath test Negative
Vehicle direction SE to NW
FRV Journey Commuting to/from work
Casualty Reference: 1 Age: 21 Female Driver/rider Severity: Slight

Vehicle Reference 2 Car Turning right
Not in restricted lane No skidding, jack-knifing or overturning
First point of impact Offside Age of Driver 48 Breath test Negative
Vehicle direction SW to SE
FRV Journey Commuting to/from work

Accidents between dates 01/01/2011 and 02/09/2016 (68) months

Selection:

; Refined using Accidents within selected Polygons -Data request polygons ("RPS Enderby 15.09.2016")

Notes:

201106217 04/11/2011 Friday Time 1149 Vehicles 2 Casualties 2 Slight
 Fine without high winds Road surface Dry Daylight:
 Special Conditions None Road Type Roundabout
 V1 TRAV S/E BLABY RD ENTERS R/ABOUT LANE 1. V1 STOPS AT TRAFFIC LIGHTS ON R/ABOUT. V2 TRAV N/E LANE 3 LEAVING R/ABOUT COLLS REAR O/S V1.
 Occurred on B4114 LEICESTER ROAD ENDERBY ROUNDABOUT JW BLABY ROAD.

Vehicle Reference 1 Car Waiting to go ahead but held up
 Not in restricted lane No skidding, jack-knifing or overturning
 First point of impact Back Age of Driver 26 Breath test Negative
 Vehicle direction NW to SE
 FRV Journey 6
 Casualty Reference: 1 Age: 65 Female Passenger Severity: Slight
 Casualty Reference: 2 Age: 26 Male Driver/rider Severity: Slight

Vehicle Reference 2 Car Turning right
 Not in restricted lane No skidding, jack-knifing or overturning
 First point of impact Front Age of Driver 30 Breath test Negative
 Vehicle direction SE to NE
 FRV Journey 6

201106247 05/11/2011 Saturday Time 1324 Vehicles 2 Casualties 2 Serious
 Fine without high winds Road surface Dry Daylight:
 Special Conditions None Road Type Single carriageway
 V2 TRAV S/W TRINITY RD TURNS R TRAV N/W & COLLS V1 (M/CYCLE) TRAV S/E BLABY RD. RIDER V1 HAD NOT UNDERTAKEN ANY TRAINING.
 Occurred on B582 BLABY ROAD ENDERBY JW TRINITY ROAD.

Vehicle Reference 1 Motorcycle over 500cc Going ahead
 Not in restricted lane Skidded
 First point of impact Nearside Age of Driver 19 Breath test Negative
 Vehicle direction NW to SE
 FRV Journey 6
 Casualty Reference: 1 Age: 19 Male Driver/rider Severity: Serious

Vehicle Reference 2 Car Turning right
 Not in restricted lane No skidding, jack-knifing or overturning
 First point of impact Front Age of Driver 38 Breath test Negative
 Vehicle direction NE to NW
 FRV Journey 6
 Casualty Reference: 2 Age: 38 Female Driver/rider Severity: Slight

Accidents between dates 01/01/2011 and 02/09/2016 (68) months

Selection:

; Refined using Accidents within selected Polygons -Data request polygons ("RPS Enderby 15.09.2016")

Notes:

201106730 28/11/2011 Monday Time 2140 Vehicles 2 Casualties 3 Slight
Fine without high winds Road surface Dry Darkness: street lights present and lit
Special Conditions None Road Type Roundabout
V2 TRAV S/E BLABY RD MISTAKES GREEN PED LIGHT FOR TRAFFIC LIGHT ENTERS R/ABOUT TRAV AHEAD & COLLS
N/S V1 TRAV N/E LEICS RD LEAVING R/ABOUT.
Occurred on B4114 LEICESTER ROAD ENDERBY ROUNDABOUT JW BLABY ROAD.

Vehicle Reference	1	Car	Going ahead
Not in restricted lane			No skidding, jack-knifing or overturning
First point of impact	Front		Age of Driver 50 Breath test Negative
Vehicle direction	SW to NE		
FRV			Journey 6
Casualty Reference:	1	Age: 50 Male	Driver/rider Severity: Slight
Casualty Reference:	2	Age: 26 Male	Passenger Severity: Slight
Vehicle Reference	2	Car	Going ahead
Not in restricted lane			No skidding, jack-knifing or overturning
First point of impact	Front		Age of Driver 60 Breath test Negative
Vehicle direction	NW to SE		
FRV			Journey 6
Casualty Reference:	3	Age: 60 Female	Driver/rider Severity: Slight

Accidents between dates 01/01/2011 and 02/09/2016 (68) months

Selection:

; Refined using Accidents within selected Polygons -Data request polygons ("RPS Enderby 15.09.2016")

Notes:

201106813 01/12/2011 Thursday Time 0800 Vehicles 2 Casualties 2 Slight
Fine without high winds Road surface Dry Daylight:
Special Conditions None Road Type Single carriageway
V2 TRAV N/W BLABY ROAD COLLS REAR V1 STATIONARY AHEAD HELD IN TRAFFIC QUEUE.
Occurred on B582 BLABY ROAD ENDERBY APPROX 130M S/E FOXHUNTER ROUNDABOUT.

Vehicle Reference 1 Car Going ahead
Not in restricted lane No skidding, jack-knifing or overturning
First point of impact Back Age of Driver 55 Breath test Negative
Vehicle direction SE to NW
FRV Journey Commuting to/from work
Casualty Reference: 1 Age: 55 Female Driver/rider Severity: Slight

Vehicle Reference 2 Car Going ahead
Not in restricted lane No skidding, jack-knifing or overturning
First point of impact Front Age of Driver 51 Breath test Negative
Vehicle direction SE to NW
FRV Journey Commuting to/from work
Casualty Reference: 2 Age: 51 Female Driver/rider Severity: Slight

201107059 13/12/2011 Tuesday Time 1700 Vehicles 1 Casualties 1 Slight
Fine without high winds Road surface Dry Darkness: street lights present and lit
Special Conditions None Road Type Single carriageway
PED TRAV N/E CROSSES ROAD DAZZLED BY V1 HEADLIGHTS & COLLS N/S V1 TRAV N/W MILL LANE IN SLOW MOVING TRAFFIC.
Occurred on B582 MILL LANE ENDERBY JW QUARRY LANE. OUTSIDE HOUSE NO 37.

Vehicle Reference 1 Car Going ahead
Not in restricted lane No skidding, jack-knifing or overturning
First point of impact Nearside Age of Driver 30 Breath test Negative
Vehicle direction SE to NW
FRV Journey Journey as part of work
Casualty Reference: 1 Age: 20 Female Pedestrian Severity: Slight
Pedestrian Direction: NE

Accidents between dates 01/01/2011 and 02/09/2016 (68) months

Selection:

; Refined using Accidents within selected Polygons -Data request polygons ("RPS Enderby 15.09.2016")

Notes:

201107221 20/12/2011 Tuesday Time 1110 Vehicles 2 Casualties 1 Slight
 Fine without high winds Road surface Dry Daylight:
 Special Conditions None Road Type Roundabout

NO STATS 19 FORM RECEIVED.

Occurred on B4114 LEICS RD ENDERBY FOX HUNTER ROUNDABOUT. EXACT LOCATION UNKNOWN.

Vehicle Reference 1 Car Going ahead
 Not in restricted lane No skidding, jack-knifing or overturning
 First point of impact Front Age of Driver Breath test Not requested
 Vehicle direction SE to NW
 FRV Journey 6
 Casualty Reference: 1 Age: Male Passenger Severity: Slight

Vehicle Reference 2 Car Going ahead
 Not in restricted lane No skidding, jack-knifing or overturning
 First point of impact Back Age of Driver Breath test Not requested
 Vehicle direction SE to NW
 FRV Journey 6

201107411 29/12/2011 Thursday Time 1604 Vehicles 2 Casualties 1 Slight
 Fine without high winds Road surface Wet/Damp Darkness: street lights present and lit
 Special Conditions None Road Type Dual carriageway
 V2 TRAV N LANE 2 NARBOROUGH RD SOUTH SLOWS FOR RED TRAFFIC LIGHTS AHEAD. V1 FAILS TO SEE SLOWING TRAFFIC & COLLS REAR V2.
 Occurred on B4114 NARBOROUGH ROAD SOUTH ENDERBY ROUNDABOUT JW LUBBESTHORPE WAY.

Vehicle Reference 1 Car Going ahead
 Not in restricted lane No skidding, jack-knifing or overturning
 First point of impact Front Age of Driver 42 Breath test Not requested
 Vehicle direction S to N
 FRV Journey Journey as part of work
 Vehicle Reference 2 Car Slowing or Stopping
 Not in restricted lane No skidding, jack-knifing or overturning
 First point of impact Back Age of Driver 20 Breath test Not requested
 Vehicle direction S to N
 FRV Journey Commuting to/from work
 Casualty Reference: 1 Age: 20 Female Driver/rider Severity: Slight

Accidents between dates 01/01/2011 and 02/09/2016 (68) months

Selection: Notes:
; Refined using Accidents within selected Polygons -Data request
polygons ("RPS Enderby 15.09.2016")

201200070 05/01/2012 Thursday Time 1200 Vehicles 2 Casualties 2 Slight
Raining with high winds Road surface Wet/Damp Daylight:
Special Conditions None Road Type Roundabout
V1 TRAV S/E BLABY RD ENTERS ROUNDABOUT TRAV AHEAD LANE 1 & COLLS N/S V2 TRAV N/E LANE 2 LEAVING
ROUNDABOUT.
Occurred on B4114 LEICESTER ROAD ENDERBY ROUNDABOUT JW BLABY ROAD.

Vehicle Reference 1 Car Going ahead
Not in restricted lane No skidding, jack-knifing or overturning
First point of impact Offside Age of Driver Breath test Driver not contacted
Vehicle direction NW to SE
FRV Journey 6

Vehicle Reference 2 Car Going ahead
Not in restricted lane No skidding, jack-knifing or overturning
First point of impact Nearside Age of Driver 38 Breath test Driver not contacted
Vehicle direction SW to NE
FRV Journey 6

Casualty Reference: 1 Age: 38 Male Driver/rider Severity: Slight

Casualty Reference: 2 Age: 11 Male Passenger Severity: Slight

Accidents between dates 01/01/2011 and 02/09/2016 (68) months

Selection:

; Refined using Accidents within selected Polygons -Data request polygons ("RPS Enderby 15.09.2016")

Notes:

201200108 06/01/2012 Friday Time 0956 Vehicles 4 Casualties 2 Slight
 Fine without high winds Road surface Dry Daylight:
 Special Conditions None Road Type Dual carriageway
 V1 TRAV N STOPS FOR UNKNOWN REASON. V2 COLLS REAR V1. V3 COLLS REAR V2. V4 COLLS REAR V3.
 Occurred on B4114 ST JOHNS ENDERBY OPPOSITE POLICE HQ.

Vehicle Reference 1 Car Waiting to go ahead but held up
 Not in restricted lane No skidding, jack-knifing or overturning
 First point of impact Back Age of Driver 53 Breath test Negative
 Vehicle direction S to N
 FRV Journey 6

Vehicle Reference 2 Car Going ahead
 Not in restricted lane No skidding, jack-knifing or overturning
 First point of impact Front Age of Driver 69 Breath test Negative
 Vehicle direction S to N
 FRV Journey 6

Vehicle Reference 3 Car Going ahead
 Not in restricted lane No skidding, jack-knifing or overturning
 First point of impact Front Age of Driver 35 Breath test Negative
 Vehicle direction S to N
 FRV Journey 6

Vehicle Reference 4 Car Going ahead
 Not in restricted lane No skidding, jack-knifing or overturning
 First point of impact Front Age of Driver 84 Breath test Negative
 Vehicle direction S to N
 FRV Journey 6

Casualty Reference: 1 Age: 84 Male Driver/rider Severity: Slight

Casualty Reference: 2 Age: 76 Female Passenger Severity: Slight

Accidents between dates 01/01/2011 and 02/09/2016 (68) months

Selection:

; Refined using Accidents within selected Polygons -Data request polygons ("RPS Enderby 15.09.2016")

Notes:

201200104 08/01/2012 Sunday Time 1222 Vehicles 2 Casualties 1 Slight
Fine without high winds Road surface Dry Daylight:
Special Conditions None Road Type Dual carriageway
V2 TRAV N/W LANE 2 SOAR VALLEY WAY FAILS TO STOP & COLLS REAR V1 STATIONARY AHEAD HELD AT RED TRAFFIC LIGHTS.
Occurred on A563 SOAR VALLEY WAY ENDERBY JW ROUNDABOUT NARBOROUGH ROAD SOUTH.

Vehicle Reference 1 Car Waiting to go ahead but held up
Not in restricted lane No skidding, jack-knifing or overturning
First point of impact Back Age of Driver 40 Breath test Negative
Vehicle direction SE to NW
FRV Journey 6
Casualty Reference: 1 Age: 40 Male Driver/rider Severity: Slight

Vehicle Reference 2 Car Going ahead
Not in restricted lane No skidding, jack-knifing or overturning
First point of impact Front Age of Driver 69 Breath test Negative
Vehicle direction SE to NW
FRV Journey 6

201200420 23/01/2012 Monday Time 2050 Vehicles 2 Casualties 1 Slight
Fine without high winds Road surface Dry Darkness: street lights present and lit
Special Conditions None Road Type Roundabout
V2 TRAV S/E BLABY RD ENTERS R/ABOUT TRAV AHEAD LANE 2 IN FRONT V1 TRAV N/E LANE 3 TURNING R TRAV S/E.
V1 COLLS REAR V2 & LEAVES C/WAY N/S.
Occurred on B4114 LEICESTER ROAD ENDERBY JW BLABY ROAD.

Vehicle Reference 1 Car Turning right
Not in restricted lane No skidding, jack-knifing or overturning
First point of impact Front Age of Driver 23 Breath test Negative
Vehicle direction SW to SE
FRV Journey Commuting to/from work
Vehicle Reference 2 Car Going ahead
Not in restricted lane No skidding, jack-knifing or overturning
First point of impact Offside Age of Driver 21 Breath test Negative
Vehicle direction NW to SE
FRV Journey 6
Casualty Reference: 1 Age: 21 Male Driver/rider Severity: Slight

Accidents between dates 01/01/2011 and 02/09/2016 (68) months

Selection:

; Refined using Accidents within selected Polygons -Data request polygons ("RPS Enderby 15.09.2016")

Notes:

201200686 06/02/2012 Monday Time 1120 Vehicles 2 Casualties 2 Slight
 Fine without high winds Road surface Wet/Damp Daylight:
 Special Conditions None Road Type Roundabout
 V1 TRAV S/E LUBBESTHORPE WAY DISOBEYED RED TRAFFIC LIGHT & COLLS N/S V2 TRAV N/E NARBOROUGH RD SOUTH.
 Occurred on B4114 NARBOROUGH ROAD SOUTH ENDERBY ROUNDABOUT JW LUBBESTHORPE WAY.

Vehicle Reference 1 Car Going ahead
 Not in restricted lane No skidding, jack-knifing or overturning
 First point of impact Front Age of Driver 42 Breath test Negative
 Vehicle direction NW to SE
 FRV Journey 6
 Casualty Reference: 1 Age: 61 Female Passenger Severity: Slight

Vehicle Reference 2 Car Going ahead
 Not in restricted lane No skidding, jack-knifing or overturning
 First point of impact Nearside Age of Driver 22 Breath test Negative
 Vehicle direction S to NE
 FRV Journey 6
 Casualty Reference: 2 Age: 22 Male Driver/rider Severity: Slight

201201009 08/02/2012 Wednesday Time 1430 Vehicles 2 Casualties 1 Slight
 Fine without high winds Road surface Dry Daylight:
 Special Conditions None Road Type Dual carriageway
 V1 MOVES OFF TRAV S/E AT TRAFFIC LIGHTS & STALLS VEHICLE. V2 MOVES OFF BEHIND & COLLS REAR V1 STATIONARY AHEAD.
 Occurred on A563 LUBBESTHORPE WAY ENDERBY ROUNDABOUT JW NARBOROUGH RD SOUTH.

Vehicle Reference 1 Car Waiting to go ahead but held up
 Not in restricted lane No skidding, jack-knifing or overturning
 First point of impact Back Age of Driver 21 Breath test Driver not contacted
 Vehicle direction NW to SE
 FRV Journey Journey as part of work
 Casualty Reference: 1 Age: 21 Male Passenger Severity: Slight

Vehicle Reference 2 Car Moving off
 Not in restricted lane No skidding, jack-knifing or overturning
 First point of impact Front Age of Driver Breath test Driver not contacted
 Vehicle direction NW to SE
 FRV Journey 6

Accidents between dates 01/01/2011 and 02/09/2016 (68) months

Selection: ; Refined using Accidents within selected Polygons -Data request polygons ("RPS Enderby 15.09.2016")

Notes:

201200809 10/02/2012 Friday Time 1849 Vehicles 2 Casualties 1 Slight
 Fine without high winds Road surface Wet/Damp Darkness: street lights present and lit
 Special Conditions None Road Type Roundabout
 V1 TRAV N/W LANE 2 SOAR VALLEY WAY UNFAMILIAR WITH AREA PASSES THRO RED LIGHT TURNING R TRAV N/E &
 COLLS V2 TRAV N/E NARBOROUGH RD S.
 Occurred on B4114 NARBOROUGH ROAD SOUTH ENDERBY ROUNDABOUT JW SOAR VALLEY WAY.

Vehicle Reference	1	Car	Going ahead
Not in restricted lane			No skidding, jack-knifing or overturning
First point of impact	Front		Age of Driver 22 Breath test Negative
Vehicle direction	SE to NE		
FRV			Journey 6
Vehicle Reference	2	Car	Turning right
Not in restricted lane			No skidding, jack-knifing or overturning
First point of impact	Offside		Age of Driver 41 Breath test Negative
Vehicle direction	S to NE		
FRV			Journey 6
Casualty Reference:	1	Age: 41 Female Passenger	Severity: Slight

201201001 21/02/2012 Tuesday Time 1745 Vehicles 3 Casualties 1 Slight
 Fine without high winds Road surface Dry Darkness: street lights present and lit
 Special Conditions None Road Type Single carriageway
 V1 TRAV S/W TRINITY RD TURNS R IN FRONT NK V3 STATIONARY TRAV S/E ON N/S OF C/WAY BLABY RD & COLLS N/S
 V2 TRAV S/E OVERTAKING V3.
 Occurred on B582 BLABY ROAD ENDERBY JW TRINITY ROAD.

Vehicle Reference	1	Car	Turning right
Not in restricted lane			No skidding, jack-knifing or overturning
First point of impact	Front		Age of Driver 21 Breath test Not requested
Vehicle direction	NE to NW		
FRV			Journey 6
Casualty Reference:	1	Age: 21 Female Driver/rider	Severity: Slight

Vehicle Reference	2	Car	Overtaking stationary vehicle on its offside
Not in restricted lane			No skidding, jack-knifing or overturning
First point of impact	Nearside		Age of Driver 45 Breath test Not requested
Vehicle direction	NW to SE		
FRV			Journey 6

Vehicle Reference	3	Car	Waiting to go ahead but held up
Not in restricted lane			No skidding, jack-knifing or overturning
First point of impact	Did not impact		Age of Driver Breath test Driver not contacted
Vehicle direction	NW to SE		
FRV			Journey 6

Accidents between dates 01/01/2011 and 02/09/2016 (68) months

Selection:

; Refined using Accidents within selected Polygons -Data request polygons ("RPS Enderby 15.09.2016")

Notes:

201205364 22/03/2012 Thursday Time 1610 Vehicles 2 Casualties 1 Slight
 Fine without high winds Road surface Dry Daylight:
 Special Conditions None Road Type Roundabout
 V1 TRAV S/E BLABY RD ENTERS R/ABOUT TRAV AHEAD & COLLS FRONT V2 TRAV N/E LEICESTER RD LEAVING
 ROUNDABOUT IN LANE 2.
 Occurred on B4114 LEICESTER ROAD ENDERBY JW ROUNDABOUT BLABY ROAD.

Vehicle Reference 1 Car Going ahead
 Not in restricted lane No skidding, jack-knifing or overturning
 First point of impact Offside Age of Driver 75 Breath test Negative
 Vehicle direction NW to SE
 FRV Journey 6
 Casualty Reference: 1 Age: 75 Male Driver/rider Severity: Slight

Vehicle Reference 2 Car Going ahead
 Not in restricted lane No skidding, jack-knifing or overturning
 First point of impact Front Age of Driver 32 Breath test Negative
 Vehicle direction SW to NE
 FRV Journey 6

201201722 27/03/2012 Tuesday Time 1635 Vehicles 3 Casualties 1 Slight
 Fine without high winds Road surface Dry Daylight:
 Special Conditions None Road Type Single carriageway
 V1 TRAV N/W MILL HILL COLLS REAR V2 STATIONARY AHEAD. V2 COLLS REAR V3 WAITING TO TURN R TRAV N/E
 INTO BUILDERS YARD.
 Occurred on B582 MILL HILL ENDERBY JW PRIVATE DRIVE TO BUILDERS YARD.

Vehicle Reference 1 Car Going ahead
 Not in restricted lane No skidding, jack-knifing or overturning
 First point of impact Front Age of Driver 43 Breath test Not requested
 Vehicle direction SE to NW
 FRV Journey Journey as part of work
 Casualty Reference: 1 Age: 43 Male Driver/rider Severity: Slight

Vehicle Reference 2 Car Waiting to go ahead but held up
 Not in restricted lane No skidding, jack-knifing or overturning
 First point of impact Back Age of Driver 61 Breath test Not requested
 Vehicle direction SE to NW
 FRV Journey Journey as part of work

Vehicle Reference 3 Car Waiting to turn right
 Not in restricted lane No skidding, jack-knifing or overturning
 First point of impact Back Age of Driver 51 Breath test Not requested
 Vehicle direction SE to NE
 FRV Journey Journey as part of work

Accidents between dates 01/01/2011 and 02/09/2016 (68) months

Selection:

; Refined using Accidents within selected Polygons -Data request polygons ("RPS Enderby 15.09.2016")

Notes:

201202110 19/04/2012 Thursday Time 0822 Vehicles 2 Casualties 2 Slight
 Fine without high winds Road surface Dry Daylight:
 Special Conditions None Road Type Roundabout
 V2 TRAV S/W ON ROUNDABOUT CHANGES LANE L IN FRONT V1 TRAV S/W LANE 1. V1 COLLS REAR V2.
 Occurred on B4114 NARBOROUGH ROAD SOUTH ENDERBY ROUNDABOUT JW SOAR VALLEY WAY.

Vehicle Reference 1 Car Going ahead
 Not in restricted lane No skidding, jack-knifing or overturning
 First point of impact Front Age of Driver 32 Breath test Not requested
 Vehicle direction NE to SW
 FRV Journey Journey as part of work
 Casualty Reference: 1 Age: 32 Male Driver/rider Severity: Slight

Vehicle Reference 2 Car Changing lane to left
 Not in restricted lane No skidding, jack-knifing or overturning
 First point of impact Back Age of Driver 28 Breath test Not requested
 Vehicle direction NE to SW
 FRV Journey Journey as part of work
 Casualty Reference: 2 Age: 28 Male Driver/rider Severity: Slight

201205060 27/04/2012 Friday Time 1605 Vehicles 2 Casualties 1 Slight
 Raining without high winds Road surface Wet/Damp Daylight:
 Special Conditions None Road Type Dual carriageway
 V2 TRAV W GROVE FARM TRIANGLE TURNS L TRAV S/E LUBBESTHORPE WAY & V1 (M/CYCLE) TRAV N/E PENMAN
 WAY TURNING R TRAV S/E COLLS MID JCT.
 Occurred on A563 LUBBESTHORPE WAY ENDERBY JW PENMAN WAY.

Vehicle Reference 1 Motorcycle - unknown cc Turning right
 Not in restricted lane Skidded
 First point of impact Front Age of Driver 19 Breath test Driver not contacted
 Vehicle direction SW to SE
 FRV Journey 6
 Casualty Reference: 1 Age: 19 Male Driver/rider Severity: Slight

Vehicle Reference 2 Car Turning left
 Not in restricted lane No skidding, jack-knifing or overturning
 First point of impact Back Age of Driver 90 Breath test Driver not contacted
 Vehicle direction E to SE
 FRV Journey 6

Accidents between dates 01/01/2011 and 02/09/2016 (68) months

Selection:

; Refined using Accidents within selected Polygons -Data request polygons ("RPS Enderby 15.09.2016")

Notes:

201205075 06/05/2012 Sunday Time 2220 Vehicles 3 Casualties 3 Slight
Fine without high winds Road surface Dry Darkness: street lights present and lit
Special Conditions None Road Type Dual carriageway
V1 (PARAMEDIC ON CALL) TRAV N A563 CROSSES RED LIGHT & COLLS V2 MOVING OFF TRAV E PENMAN WAY. V2
CROSSES C/WAY & COLLS V3 TRAV S/E A563.
Occurred on A563 LUBBESTHORPE WAY ENDERBY JW PENMAN WAY.

Vehicle Reference 1 Car Going ahead
Not in restricted lane No skidding, jack-knifing or overturning
First point of impact Front Age of Driver 49 Breath test Not provided (medical)
Vehicle direction S to N
FRV Journey Journey as part of work
Casualty Reference: 1 Age: 49 Male Driver/rider Severity: Slight

Vehicle Reference 2 Car Moving off
Not in restricted lane No skidding, jack-knifing or overturning
First point of impact Offside Age of Driver 49 Breath test Negative
Vehicle direction W to E
FRV Journey 6
Casualty Reference: 2 Age: 49 Male Driver/rider Severity: Slight

Vehicle Reference 3 Car Moving off
Not in restricted lane No skidding, jack-knifing or overturning
First point of impact Offside Age of Driver 23 Breath test Negative
Vehicle direction W to SE
FRV Journey 6
Casualty Reference: 3 Age: 23 Male Driver/rider Severity: Slight

Accidents between dates 01/01/2011 and 02/09/2016 (68) months

Selection: Notes:
; Refined using Accidents within selected Polygons -Data request
polygons ("RPS Enderby 15.09.2016")

201205235 30/05/2012 Wednesday Time 2315 Vehicles 2 Casualties 2 Slight
Fine without high winds Road surface Dry Darkness: street lights present and lit
Special Conditions None Road Type Roundabout
V1 TRAV S/E LUBBESTHORPE WAY TO SOAR VALLEY WAY FAILS TO SEE RED TRAFFIC LIGHT & COLLS N/S V2 TRAV
N/E ON R/ABOUT NARBOROUGH RD SOUTH.
Occurred on B4114 NARBOROUGH ROAD SOUTH ENDERBY ROUNDABOUT JW LUBBESTHORPE WAY.

Vehicle Reference 1 Car Going ahead
Not in restricted lane No skidding, jack-knifing or overturning
First point of impact Front Age of Driver 52 Breath test Negative
Vehicle direction NW to SE
FRV Journey Journey as part of work
Casualty Reference: 1 Age: 52 Female Driver/rider Severity: Slight

Vehicle Reference 2 Car Going ahead
Not in restricted lane No skidding, jack-knifing or overturning
First point of impact Nearside Age of Driver 23 Breath test Negative
Vehicle direction SW to NE
FRV Journey 6
Casualty Reference: 2 Age: 21 Female Passenger Severity: Slight

201205230 02/06/2012 Saturday Time 1110 Vehicles 2 Casualties 1 Slight
Fine without high winds Road surface Dry Daylight:
Special Conditions None Road Type Roundabout
V1 (HGV) TRAV S/E LUBBESTHORPE WAY ONTO SOAR VALLEY WAY DISOBEYED TRAFFIC SIGNAL BRAKES SKIDS &
COLLS N/S V2 TRAV N/E NARBOROUGH RD SOUTH
Occurred on B4114 NARBOROUGH ROAD SOUTH ENDERBY ROUNDABOUT JW LUBBESTHORPE WAY.

Vehicle Reference 1 Goods between 3.5 and 7.5 tonnes mgw Slowing or Stopping
Not in restricted lane Skidded
First point of impact Front Age of Driver 38 Breath test Negative
Vehicle direction NW to SE
FRV Journey Journey as part of work
Vehicle Reference 2 Car Going ahead
Not in restricted lane Overturned
First point of impact Nearside Age of Driver 61 Breath test Not requested
Vehicle direction SW to NE
FRV Journey 6
Casualty Reference: 1 Age: 61 Male Driver/rider Severity: Slight

Accidents between dates 01/01/2011 and 02/09/2016 (68) months

Selection:

; Refined using Accidents within selected Polygons -Data request polygons ("RPS Enderby 15.09.2016")

Notes:

201205615 14/07/2012 Saturday Time 1820 Vehicles 2 Casualties 1 Slight
Fine without high winds Road surface Dry Daylight:
Special Conditions None Road Type Roundabout

V2 TRAV S/E BLABY RD ENTERS R/ABOUT TRAV AHEAD & COLLS REAR N/S V1 LEAVING R/ABOUT TRAV N/E LEICESTER RD. V2 LEAVES C/WAY N/S & COLLS SIGN.

Occurred on B4114 LEICESTER ROAD ENDERBY ROUNDABOUT JW BLABY ROAD.

Vehicle Reference 1 Car Going ahead
Not in restricted lane No skidding, jack-knifing or overturning
First point of impact Nearside Age of Driver 46 Breath test Negative
Vehicle direction SW to NE
FRV Journey 6

Vehicle Reference 2 Car Going ahead
Not in restricted lane No skidding, jack-knifing or overturning
First point of impact Front Age of Driver 82 Breath test Negative
Vehicle direction NW to SE
FRV Journey 6

Casualty Reference: 1 Age: 82 Female Passenger Severity: Slight

Accidents between dates 01/01/2011 and 02/09/2016 (68) months

Selection:

; Refined using Accidents within selected Polygons -Data request polygons ("RPS Enderby 15.09.2016")

Notes:

201205627 24/07/2012 Tuesday Time 1756 Vehicles 5 Casualties 1 Slight
 Fine without high winds Road surface Dry Daylight:
 Special Conditions None Road Type Dual carriageway
 V1 V2 V3 V4 & V5 TRAV S LANE 2. V1 & V2 TRAV AHEAD STOP. V3 COLLS REAR V2. V2 COLLS REAR V1. V4 COLLS REAR
 V3. V5 COLLS REAR V4.
 Occurred on B5114 NARBOROUGH ROAD SOUTH ENDEBY. APPROX 25M S LEICESTER LANE.

Vehicle Reference 1 Car Waiting to go ahead but held up
 Not in restricted lane No skidding, jack-knifing or overturning
 First point of impact Back Age of Driver 71 Breath test Negative
 Vehicle direction N to S
 FRV Journey 6

Vehicle Reference 2 Car Waiting to go ahead but held up
 Not in restricted lane No skidding, jack-knifing or overturning
 First point of impact Back Age of Driver 56 Breath test Negative
 Vehicle direction N to S
 FRV Journey Journey as part of work

Casualty Reference: 1 Age: 22 Male Passenger Severity: Slight

Vehicle Reference 3 Car Going ahead
 Not in restricted lane No skidding, jack-knifing or overturning
 First point of impact Front Age of Driver 19 Breath test Negative
 Vehicle direction N to S
 FRV Journey Journey as part of work

Vehicle Reference 4 Car Going ahead
 Not in restricted lane No skidding, jack-knifing or overturning
 First point of impact Front Age of Driver 41 Breath test Negative
 Vehicle direction N to S
 FRV Journey Journey as part of work

Vehicle Reference 5 Car Going ahead
 Not in restricted lane No skidding, jack-knifing or overturning
 First point of impact Front Age of Driver 19 Breath test Negative
 Vehicle direction N to S
 FRV Journey Journey as part of work

Accidents between dates 01/01/2011 and 02/09/2016 (68) months

Selection:

; Refined using Accidents within selected Polygons -Data request polygons ("RPS Enderby 15.09.2016")

Notes:

201205743 16/08/2012 Thursday Time 0845 Vehicles 2 Casualties 1 Slight
Fine without high winds Road surface Dry Daylight:
Special Conditions None Road Type Roundabout

V1 (LHD ARTIC) TRAV S/W LUBBESTHORPE WAY DISOBEYED TRAFFIC SIGNAL ENTERING R/ABOUT IN FRONT V2 TRAV N/E NARBOROUGH RD S. V2 COLLS O/S V1.

Occurred on B4114 NARBOROUGH ROAD SOUTH ROUNDABOUT JW LUBBESTHORPE WAY.

Vehicle Reference 1 Goods >= 7.5 tonnes mgw Going ahead
Not in restricted lane No skidding, jack-knifing or overturning
First point of impact Offside Age of Driver 57 Breath test Negative
Vehicle direction NW to SE
FRV Journey Journey as part of work

Vehicle Reference 2 Car Going ahead
Not in restricted lane No skidding, jack-knifing or overturning
First point of impact Front Age of Driver 56 Breath test Negative
Vehicle direction SW to NE
FRV Journey 6

Casualty Reference: 1 Age: 56 Male Driver/rider Severity: Slight

201205795 27/08/2012 Monday Time 1545 Vehicles 2 Casualties 1 Slight
Fine without high winds Road surface Dry Daylight:
Special Conditions None Road Type Roundabout

V1 TRAV N/E NARBOROUGH RD S DISOBEYED TRAFFIC SIGNAL TRAV AHEAD ON ROUNDABOUT. V2 TRAV S/E LUBBESTHORPE WAY COLLS N/S REAR V1.

Occurred on B4114 NARBOROUGH ROAD SOUTH ENDERBY ROUNDABOUT JW LUBBESTHORPE WAY.

Vehicle Reference 1 Car Going ahead
Not in restricted lane No skidding, jack-knifing or overturning
First point of impact Nearside Age of Driver 60 Breath test Negative
Vehicle direction S to NE
FRV Journey 6

Vehicle Reference 2 Car Going ahead
Not in restricted lane No skidding, jack-knifing or overturning
First point of impact Front Age of Driver 25 Breath test Negative
Vehicle direction NW to SE
FRV Journey 6

Casualty Reference: 1 Age: 25 Female Driver/rider Severity: Slight

Accidents between dates 01/01/2011 and 02/09/2016 (68) months

Selection:

; Refined using Accidents within selected Polygons -Data request polygons ("RPS Enderby 15.09.2016")

Notes:

201205949 08/09/2012 Saturday Time 0502 Vehicles 1 Casualties 1 Serious
Fine without high winds Road surface Dry Darkness: street lights present and lit
Special Conditions None Road Type Single carriageway
PED HAVING ALIGHTED FROM TAXI CROSSES ROAD TRAV N/E & COLLS V1 TRAV S/E MILL HILL. PED IMPAIRED BY ALCOHOL.
Occurred on B582 MILL HILL ENDERBY JW CONERY LANE.

Vehicle Reference 1 Car Going ahead
Not in restricted lane No skidding, jack-knifing or overturning
First point of impact Front Age of Driver 43 Breath test Negative
Vehicle direction NW to SE
FRV Journey 6
Casualty Reference: 1 Age: 37 Male Pedestrian Severity: Serious
Pedestrian Direction: NE

201205945 16/09/2012 Sunday Time 2037 Vehicles 2 Casualties 2 Slight
Fine without high winds Road surface Dry Darkness: street lights present and lit
Special Conditions None Road Type Roundabout
V1 TRAV N/W SOAR VALLEY WAY DISOBEYED RED TRAFFIC LIGHT TRAV AHEAD & COLLS N/S V2 TRAV S/W NARBOROUGH RD SOUTH. V2 LEAVES C/WAY O/S.
Occurred on B4114 NARBOROUGH ROAD SOUTH ROUNDABOUT JW SOAR VALLEY WAY.

Vehicle Reference 1 Car Going ahead
Not in restricted lane No skidding, jack-knifing or overturning
First point of impact Front Age of Driver 49 Breath test Negative
Vehicle direction SE to NW
FRV Journey Journey as part of work
Casualty Reference: 1 Age: 49 Male Driver/rider Severity: Slight

Vehicle Reference 2 Car Going ahead
Not in restricted lane No skidding, jack-knifing or overturning
First point of impact Nearside Age of Driver 42 Breath test Negative
Vehicle direction NE to SW
FRV Journey 6
Casualty Reference: 2 Age: 42 Female Driver/rider Severity: Slight

Accidents between dates 01/01/2011 and 02/09/2016 (68) months

Selection: Notes:
; Refined using Accidents within selected Polygons -Data request
polygons ("RPS Enderby 15.09.2016")

201206517 27/11/2012 Tuesday Time 1735 Vehicles 2 Casualties 2 Slight
Fine without high winds Road surface Dry Darkness: street lights present and lit
Special Conditions None Road Type Dual carriageway
V1 TRAV N LANE 1 CHANGES LANE R & COLLS REAR V2 TRAV AHEAD LANE 2.
Occurred on B4114 NARBOROUGH ROAD SOUTH ENDERBY. APPROX 100M S SOAR VALLEY WAY.

Vehicle Reference 1 Car Changing lane to right
Not in restricted lane No skidding, jack-knifing or overturning
First point of impact Front Age of Driver 30 Breath test Driver not contacted
Vehicle direction S to N
FRV Journey 6

Vehicle Reference 2 Car Going ahead
Not in restricted lane No skidding, jack-knifing or overturning
First point of impact Back Age of Driver 52 Breath test Driver not contacted
Vehicle direction S to N
FRV Journey 6

Casualty Reference: 1 Age: 52 Male Driver/rider Severity: Slight

Casualty Reference: 2 Age: 50 Female Passenger Severity: Slight

201206541 05/12/2012 Wednesday Time 1408 Vehicles 1 Casualties 1 Slight
Fine without high winds Road surface Dry Daylight:
Special Conditions None Road Type Roundabout
V1 (BUS) TRAV N SMITH WAY BRAKES ENTERING ROUNDABOUT & WHEELCHAIR PASSENGER UNSUPERVISED &
POSITIONED INCORRECTLY RECEIVES INJURY.
Occurred on SMITH WAY ENDERBY ROUNDABOUT JW BARTON CLOSE.

Vehicle Reference 1 Bus or coach Slowing or Stopping
Not in restricted lane No skidding, jack-knifing or overturning
First point of impact Did not impact Age of Driver 51 Breath test Not requested
Vehicle direction S to N
FRV Journey Journey as part of work

Casualty Reference: 1 Age: 93 Female Passenger Severity: Slight

Accidents between dates 01/01/2011 and 02/09/2016 (68) months

Selection:

; Refined using Accidents within selected Polygons -Data request polygons ("RPS Enderby 15.09.2016")

Notes:

201206617 16/12/2012 Sunday Time 1145 Vehicles 2 Casualties 1 Slight

Fine without high winds Road surface Wet/Damp Daylight:

Special Conditions None Road Type Roundabout

V1 TRAV N/E NARBOROUGH RD S TRAV AHEAD ON ROUNDABOUT COLLS O/S V2 TRAV S/E LUBBESTHORPE WAY. NK WHICH PARTY DISOBEYED TRAFFIC LIGHTS.

Occurred on B4114 NARBOROUGH ROAD SOUTH ENDERBY ROUNDABOUT JW LUBBESTHORPE WAY.

Vehicle Reference 1 Car Going ahead
Not in restricted lane No skidding, jack-knifing or overturning
First point of impact Front Age of Driver 33 Breath test Negative
Vehicle direction SW to NE
FRV Journey 6
Casualty Reference: 1 Age: 33 Female Driver/rider Severity: Slight

Vehicle Reference 2 Car Going ahead
Not in restricted lane No skidding, jack-knifing or overturning
First point of impact Offside Age of Driver 60 Breath test Negative
Vehicle direction NW to SE
FRV Journey 6

201206656 17/12/2012 Monday Time 1630 Vehicles 2 Casualties 1 Slight

Fine without high winds Road surface Dry Darkness: street lights present and lit

Special Conditions None Road Type Slip road

V1 & V2 TRAV N NARBOROUGH ROAD S MOVES OFF WITH GREEN TRAFFIC LIGHT TO TURN L TRAV N/W. V2 COLLS REAR V1 AHEAD.

Occurred on B4114 NARBOROUGH ROAD SOUTH ENDERBY JW LUBBESTHORPE WAY.

Vehicle Reference 1 Car Moving off
Not in restricted lane No skidding, jack-knifing or overturning
First point of impact Back Age of Driver 33 Breath test Driver not contacted
Vehicle direction S to NW
FRV Journey Commuting to/from work
Casualty Reference: 1 Age: 33 Male Driver/rider Severity: Slight

Vehicle Reference 2 Car Moving off
Not in restricted lane No skidding, jack-knifing or overturning
First point of impact Front Age of Driver 35 Breath test Driver not contacted
Vehicle direction S to NW
FRV Journey 6

Accidents between dates 01/01/2011 and 02/09/2016 (68) months

Selection: Notes:
; Refined using Accidents within selected Polygons -Data request
polygons ("RPS Enderby 15.09.2016")

201300349 05/03/2013 Tuesday Time 1120 Vehicles 2 Casualties 1 Slight
Fine without high winds Road surface Dry Daylight:
Special Conditions None Road Type Dual carriageway
V2 TRAV S/E LANE 2 LUBBESTHORPE WAY MOVES OFF & CHANGES LANE R TO TURN R TRAV S/W B4114 & COLLS N/S
V1 MOVING OFF LANE 3 TO TRAV S/W.
Occurred on A563 LUBBESTHORPE WAY ENDERBY ROUNDABOUT JW NARBOROUGH ROAD SOUTH.

Vehicle Reference 1 Car Moving off
Not in restricted lane Skidded
First point of impact Nearside Age of Driver 25 Breath test Negative
Vehicle direction NW to SW
FRV Journey 6
Casualty Reference: 1 Age: 25 Female Driver/rider Severity: Slight

Vehicle Reference 2 Car Changing lane to right
Not in restricted lane Skidded
First point of impact Offside Age of Driver 32 Breath test Negative
Vehicle direction NW to SW
FRV Journey 6

201300636 25/04/2013 Thursday Time 2144 Vehicles 2 Casualties 2 Serious
Raining without high winds Road surface Wet/Damp Darkness: street lights present and lit
Special Conditions None Road Type Roundabout
V1 TRAV S/E LUBBESTHORPE WAY DISOBEYED RED TRAFFIC LIGHTS & COLLS N/S V2 (MOPED) TURNING R TRAV S/E
ON ROUNDABOUT NARBOROUGH RD SOUTH.
Occurred on B4114 NARBOROUGH ROAD SOUTH ENDERBY ROUNDABOUT JW LUBBESTHORPE WAY.

Vehicle Reference 1 Car Going ahead
Not in restricted lane No skidding, jack-knifing or overturning
First point of impact Front Age of Driver 17 Breath test Negative
Vehicle direction NW to SE
FRV Journey 6
Casualty Reference: 1 Age: 17 Female Driver/rider Severity: Slight

Vehicle Reference 2 Motorcycle 50cc and under Turning right
Not in restricted lane No skidding, jack-knifing or overturning
First point of impact Nearside Age of Driver 21 Breath test Not provided (medical)
Vehicle direction S to SE
FRV Journey 6
Casualty Reference: 2 Age: 21 Male Driver/rider Severity: Serious

Accidents between dates 01/01/2011 and 02/09/2016 (68) months

Selection:

; Refined using Accidents within selected Polygons -Data request polygons ("RPS Enderby 15.09.2016")

Notes:

201300752 15/05/2013 Wednesday Time 1125 Vehicles 2 Casualties 1 Slight
 Raining without high winds Road surface Wet/Damp Daylight:
 Special Conditions None Road Type Roundabout
 V1 & V2 (HGV) TRAV S/E LANE 2 ON ROUNDABOUT TURNING R TRAV S/W NARBOROUGH RD S. V1 STOPS AT TRAFFIC LIGHTS & V2 COLLS REAR V1.
 Occurred on B4114 NARBOROUGH ROAD SOUTH ROUNDABOUT JW SOAR VALLEY WAY.

Vehicle Reference 1 Goods <= 3.5 tonnes mgw Waiting to go ahead but held up
 Not in restricted lane No skidding, jack-knifing or overturning
 First point of impact Back Age of Driver 59 Breath test Not requested
 Vehicle direction NW to SW
 FRV Journey 6

Vehicle Reference 2 Goods >= 7.5 tonnes mgw Slowing or Stopping
 Not in restricted lane No skidding, jack-knifing or overturning
 First point of impact Front Age of Driver 60 Breath test Not requested
 Vehicle direction NW to SW
 FRV Journey Journey as part of work

Casualty Reference: 1 Age: 60 Male Driver/rider Severity: Slight

201300856 30/05/2013 Thursday Time 1705 Vehicles 2 Casualties 1 Slight
 Fine without high winds Road surface Wet/Damp Daylight:
 Special Conditions None Road Type Dual carriageway
 V1 TRAV W LANE 1 GROVE FARM TRIANGLE TURNS L TRAV S/E & COLLS REAR V2 (CYCLE) TRAV S/E LUBBESTHORPE WAY.
 Occurred on A563 LUBBESTHORPE WAY ENDERBY JW GROVE FARM TRIANGLE.

Vehicle Reference 1 Car Turning left
 Not in restricted lane No skidding, jack-knifing or overturning
 First point of impact Front Age of Driver 57 Breath test Negative
 Vehicle direction E to SE
 FRV Journey 6

Vehicle Reference 2 Pedal cycle Going ahead
 Not in restricted lane No skidding, jack-knifing or overturning
 First point of impact Back Age of Driver 30 Breath test Not applicable
 Vehicle direction NW to SE
 FRV Journey Commuting to/from work

Casualty Reference: 1 Age: 30 Male Driver/rider Severity: Slight

Accidents between dates 01/01/2011 and 02/09/2016 (68) months

Selection:

; Refined using Accidents within selected Polygons -Data request polygons ("RPS Enderby 15.09.2016")

Notes:

201301030 18/06/2013 Tuesday Time 1850 Vehicles 2 Casualties 2 Slight
 Fine without high winds Road surface Dry Daylight:
 Special Conditions None Road Type Dual carriageway
 V1 TRAV S LANE 1 NARBOROUGH RD S COLLS REAR V2 STATIONARY AHEAD HELD AT TRAFFIC LIGHTS. V2 LEAVES
 C/WAY N/S & COLLS RAILINGS.
 Occurred on B4114 NARBOROUGH ROAD SOUTH ENDERBY JW LEICESTER LANE.

Vehicle Reference 1 Car Going ahead
 Not in restricted lane No skidding, jack-knifing or overturning
 First point of impact Front Age of Driver Breath test Driver not contacted
 Vehicle direction N to S
 FRV Journey 6

Vehicle Reference 2 Car Waiting to go ahead but held up
 Not in restricted lane No skidding, jack-knifing or overturning
 First point of impact Back Age of Driver 42 Breath test Driver not contacted
 Vehicle direction N to S
 FRV Journey 6

Casualty Reference: 1 Age: 42 Male Driver/rider Severity: Slight

Casualty Reference: 2 Age: 21 Female Passenger Severity: Slight

201301322 20/07/2013 Saturday Time 1625 Vehicles 2 Casualties 2 Slight
 Fine without high winds Road surface Dry Daylight:
 Special Conditions None Road Type Dual carriageway
 V1 TRAV N/W LANE 1 SOAR VALLEY WAY DISTRACTED BY SAT NAV BRAKES LATE & COLLS REAR V2 STATIONARY
 AHEAD HAVING STOPPED AT RED TRAFFIC LIGHT.
 Occurred on A563 SOAR VALLEY WAY ENDERBY JW ROUNDABOUT NARBOROUGH ROAD SOUTH.

Vehicle Reference 1 Car Slowing or Stopping
 Not in restricted lane No skidding, jack-knifing or overturning
 First point of impact Front Age of Driver 34 Breath test Driver not contacted
 Vehicle direction SE to NW
 FRV Journey 6

Vehicle Reference 2 Car Waiting to go ahead but held up
 Not in restricted lane No skidding, jack-knifing or overturning
 First point of impact Back Age of Driver 41 Breath test Negative
 Vehicle direction SE to NW
 FRV Journey 6

Casualty Reference: 1 Age: 41 Male Driver/rider Severity: Slight

Casualty Reference: 2 Age: 14 Male Passenger Severity: Slight

Accidents between dates 01/01/2011 and 02/09/2016 (68) months

Selection:

; Refined using Accidents within selected Polygons -Data request polygons ("RPS Enderby 15.09.2016")

Notes:

201301499 02/09/2013 Monday Time 1718 Vehicles 2 Casualties 3 Slight
 Fine without high winds Road surface Dry Daylight:
 Special Conditions None Road Type Roundabout
 V1 TRAV S/E BLABY RD WITH PED FACILITY TRAFFIC LIGHTS ON GREEN. V1 ENTERS ROUNDABOUT & COLLS FRONT
 V2 TRAV N/E LEICESTER RD.
 Occurred on B4114 NARBOROUGH ROAD SOUTH ENDERBY ROUNDABOUT JW BLABY ROAD.

Vehicle Reference 1 Car Going ahead
 Not in restricted lane No skidding, jack-knifing or overturning
 First point of impact Front Age of Driver 80 Breath test Negative
 Vehicle direction NW to SE
 FRV Journey 6
 Casualty Reference: 1 Age: 80 Male Driver/rider Severity: Slight
 Casualty Reference: 2 Age: 73 Female Passenger Severity: Slight

Vehicle Reference 2 Car Going ahead
 Not in restricted lane Skidded
 First point of impact Front Age of Driver 23 Breath test Negative
 Vehicle direction SW to NE
 FRV Journey 6
 Casualty Reference: 3 Age: 23 Male Driver/rider Severity: Slight

201301613 11/09/2013 Wednesday Time 2000 Vehicles 1 Casualties 1 Slight
 Raining without high winds Road surface Wet/Damp Darkness: street lights present and lit
 Special Conditions None Road Type Dual carriageway
 V1 SLOWING TRAV S/W ST JOHNS AT LOW SPEED IN TRAFFIC. INTOXICATED REAR SEAT PASSENGER ATTEMPTS TO
 EXIT V1 & IS INJURED FALLING ONTO C/WAY.
 Occurred on B4114 ST JOHNS ENDERBY. APPROX 110M N/E FOXHUNTER ROUNDABOUT.

Vehicle Reference 1 Car Slowing or Stopping
 Not in restricted lane No skidding, jack-knifing or overturning
 First point of impact Did not impact Age of Driver 56 Breath test Negative
 Vehicle direction NE to SW
 FRV Journey 6
 Casualty Reference: 1 Age: 21 Female Passenger Severity: Slight

Accidents between dates 01/01/2011 and 02/09/2016 (68) months

Selection:

; Refined using Accidents within selected Polygons -Data request polygons ("RPS Enderby 15.09.2016")

Notes:

201301636 18/09/2013 Wednesday Time 1110 Vehicles 2 Casualties 1 Serious
 Fine without high winds Road surface Dry Daylight:
 Special Conditions None Road Type Roundabout
 V1 TRAV S/E BLABY RD ENTERS ROUNDABOUT TRAV AHEAD & COLLS V2 TRAV N/E LANE 2 LEICESTER RD. V1 & V2
 COLLS RAILINGS ON ROADABOUT.
 Occurred on B4114 LEICESTER ROAD ENDERBY ROUNDABOUT JW BLABY ROAD.

Vehicle Reference 1 Car Going ahead
 Not in restricted lane No skidding, jack-knifing or overturning
 First point of impact Front Age of Driver 70 Breath test Not provided (medical)
 Vehicle direction NW to SE
 FRV Journey 6
 Casualty Reference: 1 Age: 70 Male Driver/rider Severity: Serious

Vehicle Reference 2 Car Going ahead
 Not in restricted lane No skidding, jack-knifing or overturning
 First point of impact Front Age of Driver 44 Breath test Negative
 Vehicle direction SW to NE
 FRV Journey Journey as part of work

201301667 19/09/2013 Thursday Time 1053 Vehicles 2 Casualties 1 Slight
 Raining without high winds Road surface Wet/Damp Daylight:
 Special Conditions None Road Type Single carriageway
 V2 TRAV S ST JOHNS COLLS O/S V1 TRAV W MOVES OFF ON PRIVATE ROAD TRAV AHEAD AT JCT WITH GREEN TRAFFIC
 LIGHT.
 Occurred on B4114 ST JOHNS ENDERBY JW EXIT ROAD FROM POLICE HQ.

Vehicle Reference 1 Car Moving off
 Not in restricted lane No skidding, jack-knifing or overturning
 First point of impact Offside Age of Driver 53 Breath test Not requested
 Vehicle direction E to W
 FRV Journey Journey as part of work
 Casualty Reference: 1 Age: 53 Female Driver/rider Severity: Slight

Vehicle Reference 2 Car Going ahead
 Not in restricted lane No skidding, jack-knifing or overturning
 First point of impact Front Age of Driver 36 Breath test Not requested
 Vehicle direction N to S
 FRV Journey 6

Accidents between dates 01/01/2011 and 02/09/2016 (68) months

Selection:

; Refined using Accidents within selected Polygons -Data request polygons ("RPS Enderby 15.09.2016")

Notes:

201301849 28/09/2013 Saturday Time 0600 Vehicles 2 Casualties 1 Slight
Fine without high winds Road surface Dry Darkness: street lights present and lit
Special Conditions None Road Type Roundabout
V2 TRAV N/W SOAR VALLEY WAY DISOBEYED RED TRAFFIC LIGHT & COLLS FRONT V1 MOVING OFF TRAV S/W
NARBOROUGH RD SOUTH.
Occurred on B4114 NARBOROUGH ROAD SOUTH ENDERBY ROUNDABOUT JW SOAR VALLEY WAY.

Vehicle Reference 1 Car Moving off
Not in restricted lane No skidding, jack-knifing or overturning
First point of impact Front Age of Driver 55 Breath test Negative
Vehicle direction NE to SW
FRV Journey 6

Vehicle Reference 2 Car Going ahead
Not in restricted lane No skidding, jack-knifing or overturning
First point of impact Offside Age of Driver 41 Breath test Negative
Vehicle direction SE to NW
FRV Journey Journey as part of work

Casualty Reference: 1 Age: 41 Male Driver/rider Severity: Slight

Accidents between dates 01/01/2011 and 02/09/2016 (68) months

Selection: Notes:
; Refined using Accidents within selected Polygons -Data request
polygons ("RPS Enderby 15.09.2016")

201301917 23/10/2013 Wednesday Time 0852 Vehicles 4 Casualties 1 Slight
Fine without high winds Road surface Dry Daylight:
Special Conditions None Road Type Dual carriageway
V1 TRAV N/E LANE 2 ST JOHNS SLOWS TO ALLOW NK V4 TRAV LANE 1 TO CHANGE LANE R. V3 COLLS REAR V2. V2
COLLS REAR V1. NO COLLS V1 & V4.
Occurred on B4114 ST JOHNS ENDERBY JW ROUNDABOUT BLABY ROAD.

Vehicle Reference	1	Car							
									Slowing or Stopping
									No skidding, jack-knifing or overturning
First point of impact	Back		Age of Driver	63	Breath test	Negative			
Vehicle direction	SW to NE								
FRV								Journey	Journey as part of work
Vehicle Reference	2	Car							Going ahead
									No skidding, jack-knifing or overturning
First point of impact	Back		Age of Driver	29	Breath test	Negative			
Vehicle direction	SW to NE								
FRV								Journey	6
Casualty Reference:	1	Age:	2	Male	Passenger			Severity:	Slight
Vehicle Reference	3	Car							Going ahead
									No skidding, jack-knifing or overturning
First point of impact	Front		Age of Driver	46	Breath test	Negative			
Vehicle direction	SW to NE								
FRV								Journey	6
Vehicle Reference	4	Car							Changing lane to right
									No skidding, jack-knifing or overturning
First point of impact	Did not impact		Age of Driver		Breath test	Driver not contacted			
Vehicle direction	SW to NE								
FRV								Journey	6

Accidents between dates 01/01/2011 and 02/09/2016 (68) months

Selection:

; Refined using Accidents within selected Polygons -Data request polygons ("RPS Enderby 15.09.2016")

Notes:

201302026 05/11/2013 Tuesday Time 1720 Vehicles 2 Casualties 4 Slight
 Fine without high winds Road surface Dry Darkness: street lights present and lit
 Special Conditions None Road Type Roundabout
 V1 & V2 MOVE OFF TRAV S/W FROM TRAFFIC LIGHTS ON ROUNDABOUT. V1 AHEAD MOVES OFF SLOWLY LOOKING FOR CAR PARK ENTRANCE & V2 COLLS REAR V1.
 Occurred on B4114 LEICESTER ROAD ENDERBY ROUNDABOUT JW BLABY ROAD.

Vehicle Reference	1	Car			Moving off		
					No skidding, jack-knifing or overturning		
Not in restricted lane							
First point of impact	Back		Age of Driver	41	Breath test	Negative	
Vehicle direction	NE to SW						
FRV					Journey	6	
Casualty Reference:	1	Age:	41	Female	Driver/rider	Severity:	Slight
Casualty Reference:	2	Age:	20	Male	Passenger	Severity:	Slight
Casualty Reference:	3	Age:	15	Male	Passenger	Severity:	Slight
Casualty Reference:	4	Age:	10	Female	Passenger	Severity:	Slight

Vehicle Reference	2	Car			Moving off		
					No skidding, jack-knifing or overturning		
Not in restricted lane							
First point of impact	Front		Age of Driver	46	Breath test	Negative	
Vehicle direction	NE to SW						
FRV					Journey	Commuting to/from work	

Accidents between dates 01/01/2011 and 02/09/2016 (68) months

Selection:

; Refined using Accidents within selected Polygons -Data request polygons ("RPS Enderby 15.09.2016")

Notes:

201302149 26/11/2013 Tuesday Time 0956 Vehicles 2 Casualties 1 Slight
Fine without high winds Road surface Dry Daylight:
Special Conditions None Road Type Roundabout

V1 TRAV N/E NARBOROUGH RD S ON ROUNDABOUT DISOBEYED RED TRAFFIC LIGHT & COLLS FRONT V2 TRAV S/E ENTERING ROUNDABOUT FROM LUBBESTHORPE WAY.

Occurred on B4114 NARBOROUGH ROAD SOUTH ENDERBY ROUNDABOUT JW LUBBESTHORPE WAY.

Vehicle Reference 1 Car Going ahead
Not in restricted lane No skidding, jack-knifing or overturning
First point of impact Front Age of Driver 21 Breath test Negative
Vehicle direction SW to NE
FRV Journey Journey as part of work

Vehicle Reference 2 Car Going ahead
Not in restricted lane No skidding, jack-knifing or overturning
First point of impact Front Age of Driver 37 Breath test Negative
Vehicle direction NW to SE
FRV Journey Journey as part of work

Casualty Reference: 1 Age: 37 Male Driver/rider Severity: Slight

201302194 01/12/2013 Sunday Time 0930 Vehicles 2 Casualties 2 Slight
Fine without high winds Road surface Dry Daylight:
Special Conditions None Road Type Roundabout

V1 TRAV S/E BLABY RD CONFUSED BY TRAFFIC SIGNALS FAILS TO GIVE WAY & COLLS V2 TRAV N/E TURNING R ON ROUNDABOUT TO TRAV S/E.

Occurred on B4114 LEICESTER ROAD ENDERBY ROUNDABOUT JW BLABY ROAD.

Vehicle Reference 1 Car Moving off
Not in restricted lane No skidding, jack-knifing or overturning
First point of impact Front Age of Driver 35 Breath test Negative
Vehicle direction NW to SE
FRV Journey 6

Casualty Reference: 1 Age: 35 Male Driver/rider Severity: Slight

Vehicle Reference 2 Car Turning right
Not in restricted lane No skidding, jack-knifing or overturning
First point of impact Nearside Age of Driver 38 Breath test Negative
Vehicle direction SW to SE
FRV Journey 6

Casualty Reference: 2 Age: 38 Male Driver/rider Severity: Slight

Accidents between dates 01/01/2011 and 02/09/2016 (68) months

Selection:

; Refined using Accidents within selected Polygons -Data request polygons ("RPS Enderby 15.09.2016")

Notes:

201302263 10/12/2013 Tuesday Time 1701 Vehicles 2 Casualties 2 Slight
 Fine without high winds Road surface Dry Darkness: no street lighting
 Special Conditions None Road Type Single carriageway
 V2 TRAV E LEICESTER LANE DISTRACTED BY CHILD IN VEHICLE BRAKES LATE & COLLS REAR V1 STATIONARY
 AHEAD HELD IN QUEUE AT TRAFFIC LIGHTS.
 Occurred on C3603 LEICESTER LANE ENDERBY. NEAR SMITH WAY.

Vehicle Reference 1 Car Waiting to go ahead but held up
 Not in restricted lane No skidding, jack-knifing or overturning
 First point of impact Back Age of Driver 34 Breath test Negative
 Vehicle direction W to E
 FRV Journey Journey as part of work
 Casualty Reference: 1 Age: 34 Female Driver/rider Severity: Slight
 Casualty Reference: 2 Age: 32 Female Passenger Severity: Slight

Vehicle Reference 2 Car Slowing or Stopping
 Not in restricted lane No skidding, jack-knifing or overturning
 First point of impact Front Age of Driver 27 Breath test Negative
 Vehicle direction W to E
 FRV Journey 6

201400029 05/01/2014 Sunday Time 2200 Vehicles 2 Casualties 1 Serious
 Raining without high winds Road surface Wet/Damp Darkness: street lights present and lit
 Special Conditions None Road Type Single carriageway
 V2 (CYCLE) TRAV N/E ST JOHNS LEAVES FOOTWAY TO CROSS ROAD & COLLS N/S V1 TRAV W OLD CHURCH RD
 TURNING L TRAV S/W ST JOHNS.
 Occurred on OLD CHURCH ROAD ENDERBY JW ST JOHNS.

Vehicle Reference 1 Car Turning left
 Not in restricted lane No skidding, jack-knifing or overturning
 First point of impact Nearside Age of Driver 40 Breath test Negative
 Vehicle direction E to SW
 FRV Journey Journey as part of work
 Vehicle Reference 2 Pedal cycle Going ahead
 Not in restricted lane No skidding, jack-knifing or overturning
 First point of impact Front Age of Driver 24 Breath test Not applicable
 Vehicle direction SW to NE
 FRV Journey 6
 Casualty Reference: 1 Age: 24 Male Driver/rider Severity: Serious

Accidents between dates 01/01/2011 and 02/09/2016 (68) months

Selection:

; Refined using Accidents within selected Polygons -Data request polygons ("RPS Enderby 15.09.2016")

Notes:

201400084 15/01/2014 Wednesday Time 1611 Vehicles 5 Casualties 1 Slight
 Fine without high winds Road surface Wet/Damp Daylight:
 Special Conditions None Road Type Single carriageway
 V1 TRAV W CROSSES C/WAY TO OVERTAKE V5 (CYCLE) IN FRONT V2 V3 & V4 TRAV E. ALL BRAKE TO AVOID V1. V4
 COLLS REAR V3. V3 COLLS REAR V2.
 Occurred on C3603 LEICESTER LANE ENDERBY. EXACT LOCATION UNKNOWN.

Vehicle Reference 1 Car Overtaking moving vehicle on its offside
 Not in restricted lane No skidding, jack-knifing or overturning
 First point of impact Did not impact Age of Driver Breath test Driver not contacted
 Vehicle direction E to W
 FRV Journey 6

Vehicle Reference 2 Car Slowing or Stopping
 Not in restricted lane No skidding, jack-knifing or overturning
 First point of impact Back Age of Driver 42 Breath test Negative
 Vehicle direction W to E
 FRV Journey Journey as part of work

Vehicle Reference 3 Car Slowing or Stopping
 Not in restricted lane No skidding, jack-knifing or overturning
 First point of impact Back Age of Driver 22 Breath test Negative
 Vehicle direction W to E
 FRV Journey Commuting to/from work

Vehicle Reference 4 Car Slowing or Stopping
 Not in restricted lane No skidding, jack-knifing or overturning
 First point of impact Front Age of Driver 20 Breath test Negative
 Vehicle direction W to E
 FRV Journey Commuting to/from work

Casualty Reference: 1 Age: 20 Female Driver/rider Severity: Slight

Vehicle Reference 5 Pedal cycle Going ahead
 Not in restricted lane No skidding, jack-knifing or overturning
 First point of impact Did not impact Age of Driver Breath test Not applicable
 Vehicle direction E to W
 FRV Journey 6

Accidents between dates 01/01/2011 and 02/09/2016 (68) months

Selection:

; Refined using Accidents within selected Polygons -Data request polygons ("RPS Enderby 15.09.2016")

Notes:

201400131 15/01/2014 Wednesday Time 0858 Vehicles 2 Casualties 1 Slight
 Fine without high winds Road surface Dry Daylight:
 Special Conditions None Road Type Single carriageway
 V1 TRAV N/E LANE 1 BRAKES FOR NK REASON SWERVES R & COLLS N/S V2 TRAV N/E LANE 2 ST JOHNS.
 Occurred on B4114 ST JOHNS ENDERBY. OUTSIDE PALMERS GARDEN CENTRE.

Vehicle Reference 1 Car Slowing or Stopping
 Not in restricted lane No skidding, jack-knifing or overturning
 First point of impact Offside Age of Driver 44 Breath test Not requested
 Vehicle direction SW to NE
 FRV Journey Commuting to/from work

Vehicle Reference 2 Car Going ahead
 Not in restricted lane No skidding, jack-knifing or overturning
 First point of impact Nearside Age of Driver 43 Breath test Not requested
 Vehicle direction SW to NE
 FRV Journey Commuting to/from work

Casualty Reference: 1 Age: 43 Female Driver/rider Severity: Slight

201400166 29/01/2014 Wednesday Time 0754 Vehicles 2 Casualties 2 Slight
 Raining without high winds Road surface Wet/Damp Darkness: street lights present but unlit
 Special Conditions None Road Type Dual carriageway
 V1 (ARTIC) TRAV S LANE 2 CHANGES LANE L & COLLS O/S V2 TRAV S LANE1.
 Occurred on B4114 NARBOROUGH ROAD SOUTH ENDERBY. OUTSIDE POLICE HQ.

Vehicle Reference 1 Goods >= 7.5 tonnes mgw Changing lane to left
 Not in restricted lane No skidding, jack-knifing or overturning
 First point of impact Front Age of Driver 59 Breath test Negative
 Vehicle direction N to S
 FRV Journey Journey as part of work

Vehicle Reference 2 Car Going ahead
 Not in restricted lane No skidding, jack-knifing or overturning
 First point of impact Offside Age of Driver 32 Breath test Negative
 Vehicle direction N to S
 FRV Journey Commuting to/from work

Casualty Reference: 1 Age: 32 Female Driver/rider Severity: Slight

Casualty Reference: 2 Age: 37 Male Passenger Severity: Slight

Accidents between dates 01/01/2011 and 02/09/2016 (68) months

Selection:

; Refined using Accidents within selected Polygons -Data request polygons ("RPS Enderby 15.09.2016")

Notes:

201400224 02/02/2014 Sunday Time 1520 Vehicles 2 Casualties 2 Slight
Fine without high winds Road surface Dry Daylight:

Special Conditions None Road Type Roundabout

V1 TRAV S/W ENTERING NARBOROUGH RD S & V2 (M/CYCLE) TRAV S/E LEAVING ROUNDABOUT ONTO SOAR VALLEY WAY COLLS O/S TO FRONT.

Occurred on B4114 NARBOROUGH ROAD SOUTH ROUNDABOUT JW SOAR VALLEY WAY.

Vehicle Reference 1 Car Going ahead
Not in restricted lane No skidding, jack-knifing or overturning
First point of impact Offside Age of Driver 61 Breath test Negative
Vehicle direction NE to SW
FRV Journey 6

Casualty Reference: 1 Age: 61 Male Driver/rider Severity: Slight

Vehicle Reference 2 Motorcycle over 500cc Going ahead
Not in restricted lane No skidding, jack-knifing or overturning
First point of impact Front Age of Driver 45 Breath test Negative
Vehicle direction NW to SE
FRV Journey 6

Casualty Reference: 2 Age: 45 Male Driver/rider Severity: Slight

201400430 04/02/2014 Tuesday Time 0745 Vehicles 2 Casualties 1 Slight
Fine without high winds Road surface Dry Daylight:

Special Conditions None Road Type Dual carriageway

V1 TRAV W PENMAN WAY COLLS REAR V2 STATIONARY AHEAD AT ROUNDABOUT.

Occurred on PENMAN WAY ENDERBY ROUNDABOUT JW SMITH WAY

Vehicle Reference 1 Car Going ahead
Not in restricted lane No skidding, jack-knifing or overturning
First point of impact Front Age of Driver 45 Breath test Driver not contacted
Vehicle direction E to W
FRV Unknown Journey 6

Vehicle Reference 2 Car Waiting to go ahead but held up
Not in restricted lane No skidding, jack-knifing or overturning
First point of impact Back Age of Driver 56 Breath test Driver not contacted
Vehicle direction E to W
FRV Unknown Journey 6

Casualty Reference: 1 Age: 56 Female Driver/rider Severity: Slight

Accidents between dates 01/01/2011 and 02/09/2016 (68) months

Selection: Notes:

; Refined using Accidents within selected Polygons -Data request polygons ("RPS Enderby 15.09.2016")

201400269 12/02/2014 Wednesday Time 2228 Vehicles 2 Casualties 1 Slight
Raining with high winds Road surface Wet/Damp Darkness: street lights present and lit
Special Conditions None Road Type Roundabout
V2 TRAV N/W SOAR VALLEY WAY DISOBEYED RED TRAFFIC LIGHT & COLLS
N/S V1 TRAV S/W ON ROUNDABOUT NARBOROUGH RD SOUTH.
Occurred on B4114 NARBOROUGH ROAD SOUTH ENDERBY ROUNDABOUT JW SOAR VALLEY WAY.

Vehicle Reference	1	Car				Slowing or Stopping
Not in restricted lane					Skidded	
First point of impact	Front		Age of Driver	25	Breath test	Negative
Vehicle direction	NE to SW					
FRV	Unknown				Journey	Other/Not known
Vehicle Reference	2	Car				Going ahead
Not in restricted lane					No skidding, jack-knifing or overturning	
First point of impact	Nearside		Age of Driver	34	Breath test	Negative
Vehicle direction	SE to NW					
FRV	Unknown				Journey	Other/Not known
Casualty Reference:	1	Age:	34	Male	Driver/rider	Severity: Slight

201400534 23/03/2014 Sunday Time 2101 Vehicles 2 Casualties 1 Slight
Fine without high winds Road surface Wet/Damp Darkness: street lights present and lit
Special Conditions None Road Type Roundabout
V2 TRAV N/W SOAR VALLEY WAY DISOBEYED RED TRAFFIC LIGHT & COLLS FRONT V1 TRAV S/W NARBOROUGH RD S.
DRIVER V2 IMPAIRED BY ALCOHOL.
Occurred on B4114 NARBOROUGH ROAD SOUTH ENDERBY ROUNDABOUT JW SOAR VALLEY WAY.

Vehicle Reference	1	Car				Going ahead
Not in restricted lane					No skidding, jack-knifing or overturning	
First point of impact	Front		Age of Driver	41	Breath test	Negative
Vehicle direction	NE to SW					
FRV					Journey	6
Casualty Reference:	1	Age:	41	Male	Driver/rider	Severity: Slight
Vehicle Reference	2	Car				Going ahead
Not in restricted lane					No skidding, jack-knifing or overturning	
First point of impact	Offside		Age of Driver	57	Breath test	Positive
Vehicle direction	SE to NW					
FRV					Journey	6

Accidents between dates 01/01/2011 and 02/09/2016 (68) months

Selection: ; Refined using Accidents within selected Polygons -Data request polygons ("RPS Enderby 15.09.2016")
Notes:

201400794 01/05/2014 Thursday Time 1312 Vehicles 2 Casualties 1 Slight
Fine without high winds Road surface Dry Daylight:
Special Conditions None Road Type Roundabout

V1 TRAV S/E BLABY RD MISTAKES GREEN PED LIGHT FOR TRAFFIC LIGHTS ENTERS ROUNDABOUT TRAV AHEAD & COLLS V2 TRAV N/E LEICESTER RD ON ROUNDABOUT. V1 & V2 LEAVES C/WAY ONTO CENTRAL RESERVATION & COLLS TRAFFIC SIGNAL.

Occurred on B4114 LEICESTER ROAD ENDERBY ROUNDABOUT JW BLABY ROAD.

Vehicle Reference 1 Car Going ahead
Not in restricted lane No skidding, jack-knifing or overturning
First point of impact Offside Age of Driver 68 Breath test Not provided (medical)
Vehicle direction NW to SE
FRV Unknown Journey Other/Not known
Casualty Reference: 1 Age: 68 Male Driver/rider Severity: Slight

Vehicle Reference 2 Car Going ahead
Not in restricted lane No skidding, jack-knifing or overturning
First point of impact Nearside Age of Driver 19 Breath test Negative
Vehicle direction SW to NE
FRV Unknown Journey Other/Not known

201400825 12/05/2014 Monday Time 1700 Vehicles 2 Casualties 1 Serious
Fine without high winds Road surface Dry Daylight:
Special Conditions None Road Type Dual carriageway

V2 TRAV E ON PRIVATE RD DISOBEYED RED TRAFFIC LIGHT TURNING R TRAV S & COLLS V1 TRAV N ST JOHNS.
Occurred on B4114 ST JOHNS ENDERBY JW PRIVATE ROAD TO PARK & RIDE.

Vehicle Reference 1 Car Going ahead
Not in restricted lane No skidding, jack-knifing or overturning
First point of impact Front Age of Driver 64 Breath test Negative
Vehicle direction S to N
FRV Unknown Journey 6

Vehicle Reference 2 Car Turning right
Not in restricted lane No skidding, jack-knifing or overturning
First point of impact Offside Age of Driver 61 Breath test Negative
Vehicle direction W to S
FRV Unknown Journey 6

Casualty Reference: 1 Age: 61 Male Driver/rider Severity: Serious

Accidents between dates 01/01/2011 and 02/09/2016 (68) months

Selection:

; Refined using Accidents within selected Polygons -Data request polygons ("RPS Enderby 15.09.2016")

Notes:

201405071 04/06/2014 Wednesday Time 1545 Vehicles 2 Casualties 1 Slight
 Fine without high winds Road surface Dry Daylight:
 Special Conditions None Road Type Dual carriageway
 NO STATS 19 FORM RECEIVED.
 Occurred on B4114 ST JOHNS ENDERBY. OUTSIDE GARDEN CENTRE.

Vehicle Reference 1 Car Going ahead
 Not in restricted lane No skidding, jack-knifing or overturning
 First point of impact Front Age of Driver 45 Breath test Not requested
 Vehicle direction NE to SW
 FRV Unknown Journey 6
 Casualty Reference: 1 Age: 45 Female Driver/rider Severity: Slight

Vehicle Reference 2 Car Going ahead
 Not in restricted lane No skidding, jack-knifing or overturning
 First point of impact Back Age of Driver 56 Breath test Not requested
 Vehicle direction NE to SW
 FRV Unknown Journey 6

201401234 14/07/2014 Monday Time 1815 Vehicles 3 Casualties 1 Slight
 Fine without high winds Road surface Dry Daylight:
 Special Conditions None Road Type Single carriageway
 V2 TRAV E LEICESTER LANE BRAKES TO AVOID TREE BRANCH FALLING FROM V3 (NK HGV) & V1 TRAV BEHIND COLLS REAR V2.
 Occurred on C3603 LEICESTER LANE ENDERBY. EXACT LOCATION UNKNOWN.

Vehicle Reference 1 Car Going ahead
 Not in restricted lane No skidding, jack-knifing or overturning
 First point of impact Front Age of Driver 20 Breath test Driver not contacted
 Vehicle direction W to E
 FRV Unknown Journey 6

Vehicle Reference 2 Car Slowing or Stopping
 Not in restricted lane No skidding, jack-knifing or overturning
 First point of impact Back Age of Driver 28 Breath test Driver not contacted
 Vehicle direction W to E
 FRV Unknown Journey 6

Casualty Reference: 1 Age: 28 Female Driver/rider Severity: Slight

Vehicle Reference 3 Goods between 3.5 and 7.5 tonnes mgw Going ahead
 Not in restricted lane No skidding, jack-knifing or overturning
 First point of impact Did not impact Age of Driver Breath test Driver not contacted
 Vehicle direction W to E
 FRV Unknown Journey 6

Accidents between dates 01/01/2011 and 02/09/2016 (68) months

Selection:

; Refined using Accidents within selected Polygons -Data request polygons ("RPS Enderby 15.09.2016")

Notes:

201401370 24/07/2014 Thursday Time 1310 Vehicles 2 Casualties 2 Slight
 Fine without high winds Road surface Dry Daylight:
 Special Conditions None Road Type Roundabout
 V1 TURNING R ON ROUNDABOUT TRAV S/W DISOBEYED RED TRAFFIC LIGHT & COLLS O/S V2 TRAV N/W ENTERING ROUNDABOUT FROM ENDERBY RD.
 Occurred on B4114 LEICESTER ROAD ENDERBY ROUNDABOUT JW ENDERBY RD.

Vehicle Reference 1 Car Going ahead
 Not in restricted lane No skidding, jack-knifing or overturning
 First point of impact Front Age of Driver 75 Breath test Negative
 Vehicle direction NW to SW
 FRV Unknown Journey Other/Not known
 Casualty Reference: 1 Age: 75 Female Driver/rider Severity: Slight

Vehicle Reference 2 Car Going ahead
 Not in restricted lane No skidding, jack-knifing or overturning
 First point of impact Offside Age of Driver 25 Breath test Negative
 Vehicle direction SE to NW
 FRV Unknown Journey Other/Not known
 Casualty Reference: 2 Age: 25 Female Driver/rider Severity: Slight

201401678 15/08/2014 Friday Time 1047 Vehicles 2 Casualties 1 Slight
 Fine without high winds Road surface Dry Daylight:
 Special Conditions None Road Type Dual carriageway
 V1 (ARTIC) TRAV N/E PENMAN WAY TURNS R TRAV S/E LUBBESTHORPE WAY. V2 TRAV N/W LUBBESTHORPE WAY DISOBEYED RED TRAFFIC LIGHT & COLLS V1.
 Occurred on A563 LUBBESTHORPE WAY ENDERBY JW PENMAN WAY.

Vehicle Reference 1 Goods >= 7.5 tonnes mgw Turning right
 Not in restricted lane No skidding, jack-knifing or overturning
 First point of impact Offside Age of Driver 42 Breath test Not requested
 Vehicle direction SW to SE
 FRV Unknown Journey Journey as part of work
 Vehicle Reference 2 Car Going ahead
 Not in restricted lane No skidding, jack-knifing or overturning
 First point of impact Front Age of Driver 55 Breath test Not requested
 Vehicle direction SE to NW
 FRV Unknown Journey Journey as part of work
 Casualty Reference: 1 Age: 55 Female Driver/rider Severity: Slight

Accidents between dates 01/01/2011 and 02/09/2016 (68) months

Selection:

; Refined using Accidents within selected Polygons -Data request polygons ("RPS Enderby 15.09.2016")

Notes:

201401590 17/08/2014 Sunday Time 1840 Vehicles 2 Casualties 1 Slight
Fine without high winds Road surface Wet/Damp Daylight:
Special Conditions None Road Type Roundabout

V2 TRAV S/W NARBOROUGH RD SOUTH SUSPECTED OF DISOBEYING RED TRAFFIC LIGHT COLLS V1 TRAV S/E LEAVING ROUNDABOUT ONTO SOAR VALLEY WAY.

Occurred on B4114 NARBOROUGH ROAD SOUTH ENDERBY ROUNDABOUT JW SOAR VALLEY WAY.

Vehicle Reference 1 Car Going ahead
Not in restricted lane No skidding, jack-knifing or overturning
First point of impact Front Age of Driver 25 Breath test Negative
Vehicle direction NW to SE
FRV Unknown Journey 6

Vehicle Reference 2 Car Going ahead
Not in restricted lane No skidding, jack-knifing or overturning
First point of impact Front Age of Driver 54 Breath test Negative
Vehicle direction NE to SW
FRV Unknown Journey 6

Casualty Reference: 1 Age: 50 Female Passenger Severity: Slight

201401532 23/08/2014 Saturday Time 1644 Vehicles 2 Casualties 2 Slight
Fine without high winds Road surface Dry Daylight:
Special Conditions None Road Type Roundabout

V1 TRAV S/E LANE 1 LUBBESTHORPE WAY DISOBEYED RED TRAFFIC LIGHT TRAV AHEAD TOWARDS SOAR VALLEY WAY & COLLS N/S V2 TRAV N/E NARBOROUGH RD SOUTH.

Occurred on B4114 NARBOROUGH ROAD SOUTH ENDERBY ROUNDABOUT JW LUBBESTHORPE WAY.

Vehicle Reference 1 Car Going ahead
Not in restricted lane No skidding, jack-knifing or overturning
First point of impact Front Age of Driver 35 Breath test Negative
Vehicle direction NW to SE
FRV Unknown Journey Other/Not known

Casualty Reference: 1 Age: 35 Female Driver/rider Severity: Slight

Vehicle Reference 2 Car Going ahead
Not in restricted lane No skidding, jack-knifing or overturning
First point of impact Nearside Age of Driver 67 Breath test Negative
Vehicle direction SW to NE
FRV Unknown Journey Other/Not known

Casualty Reference: 2 Age: 67 Male Driver/rider Severity: Slight

Accidents between dates 01/01/2011 and 02/09/2016 (68) months

Selection:

; Refined using Accidents within selected Polygons -Data request polygons ("RPS Enderby 15.09.2016")

Notes:

201401667 09/09/2014 Tuesday Time 0815 Vehicles 2 Casualties 1 Slight
 Fine without high winds Road surface Dry Daylight:
 Special Conditions None Road Type Single carriageway
 V1 & V2 TRAV S SMITH WAY. V2 AHEAD SLOWS TO A STOP WAITING TO TURN R TRAV W THORPE WAY. DRIVER V1
 DISTRACTED BY PROTESTERS COLLS REAR V2.
 Occurred on SMITH WAY ENDERBY JW THORPE WAY.

Vehicle Reference	1	Car		Going ahead
				No skidding, jack-knifing or overturning
Not in restricted lane				
First point of impact	Front		Age of Driver	24
Vehicle direction	N to S		Breath test	Negative
FRV	Unknown			
			Journey	Journey as part of work
Vehicle Reference	2	Car		Waiting to turn right
				No skidding, jack-knifing or overturning
Not in restricted lane				
First point of impact	Back		Age of Driver	51
Vehicle direction	N to W		Breath test	Negative
FRV	Unknown			
			Journey	Journey as part of work
Casualty Reference:	1	Age: 51	Male	Driver/rider
				Severity: Slight

201401927 13/10/2014 Monday Time 1040 Vehicles 2 Casualties 2 Slight
 Raining with high winds Road surface Wet/Damp Daylight:
 Special Conditions None Road Type Single carriageway
 V1 TRAV N/W LEICESTER LANE TURNS R TRAV N SMITH WAY & COLLS V2 TRAV S/E NEG R BEND LEICESTER LANE.
 Occurred on C3603 LEICESTER LANE ENDERBY JW SMITH WAY.

Vehicle Reference	1	Car		Turning right
				No skidding, jack-knifing or overturning
Not in restricted lane				
First point of impact	Front		Age of Driver	51
Vehicle direction	SE to N		Breath test	Negative
FRV	Unknown			
			Journey	Journey as part of work
Vehicle Reference	2	Car		Going ahead right hand bend
				No skidding, jack-knifing or overturning
Not in restricted lane				
First point of impact	Front		Age of Driver	38
Vehicle direction	W to SE		Breath test	Negative
FRV	Unknown			
			Journey	Journey as part of work
Casualty Reference:	1	Age: 38	Female	Driver/rider
				Severity: Slight
Casualty Reference:	2	Age: 28	Female	Passenger
				Severity: Slight

Accidents between dates 01/01/2011 and 02/09/2016 (68) months

Selection: Notes:

; Refined using Accidents within selected Polygons -Data request polygons ("RPS Enderby 15.09.2016")

201402115 12/11/2014 Wednesday Time 1340 Vehicles 3 Casualties 2 Slight

Fine without high winds Road surface Dry Daylight:

Special Conditions None Road Type Dual carriageway

V2 & V3 TRAV N LANE 3 ST JOHNS. V2 STOPS BEHIND V1 STATIONARY HELD AT TRAFFIC LIGHTS. V3 FAILS TO STOP & COLLS REAR V2. V2 COLLS REAR V1. DRIVER V3 IMPAIRED BY ALCOHOL.

Occurred on B4114 ST JOHNS ENDERBY CROSSROADS JW LEICESTER LANE.

Vehicle Reference 1 Car Waiting to go ahead but held up
Not in restricted lane No skidding, jack-knifing or overturning
First point of impact Back Age of Driver 50 Breath test Negative
Vehicle direction S to N
FRV Unknown Journey 6

Vehicle Reference 2 Car Waiting to go ahead but held up
Not in restricted lane No skidding, jack-knifing or overturning
First point of impact Back Age of Driver 53 Breath test Negative
Vehicle direction S to N
FRV Unknown Journey 6

Casualty Reference: 1 Age: 53 Male Driver/rider Severity: Slight

Casualty Reference: 2 Age: 53 Female Passenger Severity: Slight

Vehicle Reference 3 Car Going ahead
Not in restricted lane No skidding, jack-knifing or overturning
First point of impact Front Age of Driver 42 Breath test Positive
Vehicle direction S to N
FRV Unknown Journey 6

Accidents between dates 01/01/2011 and 02/09/2016 (68) months

Selection:

; Refined using Accidents within selected Polygons -Data request polygons ("RPS Enderby 15.09.2016")

Notes:

201402219 26/11/2014 Wednesday Time 1540 Vehicles 2 Casualties 1 Slight
 Raining without high winds Road surface Wet/Damp Darkness: street lights present and lit
 Special Conditions None Road Type Roundabout
 V2 TRAV S/W NARBOROUGH RD S DISOBEYED RED TRAFFIC LIGHT & COLLS V1 TRAV N/W SOAR VALLEY WAY ONTO LUBBESTHORPE WAY. V1 LEAVES C/WAY N/S & COLLS WALL.
 Occurred on B4114 NARBOROUGH ROAD SOUTH ENDERBY ROUNDABOUT JW SOAR VALLEY WAY.

Vehicle Reference 1 Car Going ahead
 Not in restricted lane No skidding, jack-knifing or overturning
 First point of impact Nearside Age of Driver 40 Breath test Not requested
 Vehicle direction SE to NW
 FRV Unknown Journey Commuting to/from work
 Casualty Reference: 1 Age: 40 Male Driver/rider Severity: Slight

Vehicle Reference 2 Car Going ahead
 Not in restricted lane No skidding, jack-knifing or overturning
 First point of impact Front Age of Driver 40 Breath test Not requested
 Vehicle direction NE to SW
 FRV Unknown Journey Commuting to/from work

201405183 26/11/2014 Wednesday Time 2031 Vehicles 2 Casualties 1 Serious
 Fine without high winds Road surface Dry Darkness: street lights present and lit
 Special Conditions None Road Type Roundabout
 NO STATS 19 FORM RECEIVED.
 Occurred on B4114 LEICESTER ROAD ENDERBY ROUNDABOUT JW BLABY ROAD.

Vehicle Reference 1 Car Going ahead
 Not in restricted lane No skidding, jack-knifing or overturning
 First point of impact Offside Age of Driver 44 Breath test Not requested
 Vehicle direction NW to SE
 FRV Unknown Journey 6

Vehicle Reference 2 Motorcycle over 500cc Going ahead
 Not in restricted lane No skidding, jack-knifing or overturning
 First point of impact Front Age of Driver 21 Breath test Not requested
 Vehicle direction SW to NE
 FRV Unknown Journey 6
 Casualty Reference: 1 Age: 21 Male Driver/rider Severity: Serious

Accidents between dates 01/01/2011 and 02/09/2016 (68) months

Selection:

; Refined using Accidents within selected Polygons -Data request polygons ("RPS Enderby 15.09.2016")

Notes:

201402437 17/12/2014 Wednesday Time 1710 Vehicles 3 Casualties 2 Serious
 Other Road surface Wet/Damp Darkness: street lights present and lit
 Special Conditions None Road Type Roundabout
 V1 TRAV N/W LANE 3 SOAR VALLEY WAY DISOBEYED RED TRAFIC LIGHT & COLLS N/S V2 MOVING OFF TRAV S/W
 LANE 1 NARBOROUGH RD S. V2 COLLS N/S V3 MOVING OFF TRAV LANE 2 NARBOROUGH RD S..
 Occurred on B4114 NARBOROUGH ROAD SOUTH ENDERBY ROUNDABOUT JW SOAR VALLEY WAY.

Vehicle Reference 1 Car Going ahead
 Not in restricted lane No skidding, jack-knifing or overturning
 First point of impact Front Age of Driver 31 Breath test Negative
 Vehicle direction SE to NW
 FRV Unknown Journey Journey as part of work
 Casualty Reference: 1 Age: 31 Female Driver/rider Severity: Serious

Vehicle Reference 2 Car Moving off
 Not in restricted lane No skidding, jack-knifing or overturning
 First point of impact Nearside Age of Driver 21 Breath test Negative
 Vehicle direction NE to SW
 FRV Unknown Journey Journey as part of work
 Casualty Reference: 2 Age: 21 Female Driver/rider Severity: Slight

Vehicle Reference 3 Car Moving off
 Not in restricted lane No skidding, jack-knifing or overturning
 First point of impact Nearside Age of Driver 45 Breath test Negative
 Vehicle direction NE to SW
 FRV Unknown Journey Journey as part of work

Accidents between dates 01/01/2011 and 02/09/2016 (68) months

Selection:

; Refined using Accidents within selected Polygons -Data request polygons ("RPS Enderby 15.09.2016")

Notes:

201405199 19/12/2014 Friday Time 1635 Vehicles 2 Casualties 1 Slight
Fine without high winds Road surface Dry Darkness: street lights present and lit
Special Conditions None Road Type Single carriageway
NO STATS 19 FORM RECEIVED.
UP DATED APRIL 2015 FROM LATE FORM RECEIVED.
V1 & V2 STATIONARY TRAV S/W ON ENTRANCE TPO PARK. V1 MOVES OFF & COLLS REAR STATIONARY V2.
Occurred on B582 BLABY ROAD ENDERBY JW ENTRANCE TO JUBILEE PARK.

Vehicle Reference	1	Car	Moving off
Not in restricted lane			No skidding, jack-knifing or overturning
First point of impact	Front		Age of Driver 28 Breath test Not requested
Vehicle direction	NE to SW		
FRV	Unknown		Journey 6
Vehicle Reference	2	Car	Waiting to go ahead but held up
Not in restricted lane			No skidding, jack-knifing or overturning
First point of impact	Back		Age of Driver 45 Breath test Not requested
Vehicle direction	NE to SW		
FRV	Unknown		Journey 6

Casualty Reference: 1 Age: 45 Female Driver/rider Severity: Slight

Accidents between dates 01/01/2011 and 02/09/2016 (68) months

Selection:

; Refined using Accidents within selected Polygons -Data request polygons ("RPS Enderby 15.09.2016")

Notes:

201500116 21/01/2015 Wednesday Time 1612 Vehicles 4 Casualties 1 Slight
 Fine without high winds Road surface Wet/Damp Darkness: street lights present and lit
 Special Conditions None Road Type Dual carriageway
 V1 (TAXI) TRAV S/W LANE 1 COLLS REAR V2 STATIONARY AHEAD HELD IN TRAFFIC QUEUE. V2 COLLS REAR V3. V3 COLLS REAR V4.
 Occurred on B4114 ST JOHNS ENDERBY. APPROX 25M N/E OLD CHURCH ROAD.

Vehicle Reference	1	Taxi	Going ahead
Not in restricted lane		No skidding, jack-knifing or overturning	
First point of impact	Front	Age of Driver	41
Vehicle direction	NE to SW	Breath test	Negative
FRV	Unknown	Journey	6
Vehicle Reference	2	Car	Waiting to go ahead but held up
Not in restricted lane		No skidding, jack-knifing or overturning	
First point of impact	Back	Age of Driver	52
Vehicle direction	NE to SW	Breath test	Not requested
FRV	Unknown	Journey	6
Vehicle Reference	3	Car	Waiting to go ahead but held up
Not in restricted lane		No skidding, jack-knifing or overturning	
First point of impact	Back	Age of Driver	45
Vehicle direction	NE to SW	Breath test	Negative
FRV	Unknown	Journey	Commuting to/from work
Casualty Reference:	1	Age:	45
		Male	Driver/rider
			Severity: Slight
Vehicle Reference	4	Car	Waiting to go ahead but held up
Not in restricted lane		No skidding, jack-knifing or overturning	
First point of impact	Back	Age of Driver	50
Vehicle direction	NE to SW	Breath test	Not requested
FRV	Unknown	Journey	6

Accidents between dates 01/01/2011 and 02/09/2016 (68) months

Selection: Notes:

; Refined using Accidents within selected Polygons -Data request polygons ("RPS Enderby 15.09.2016")

201500194 08/02/2015 Sunday Time 0355 Vehicles 2 Casualties 3 Serious
 Raining without high winds Road surface Wet/Damp Darkness: street lights present and lit
 Special Conditions None Road Type Dual carriageway
 V1 TRAV N LANE 4 NARBOROUGH RD S CHANGES LANE L INTENDING TO TURN L TRAV N/W LUBBESTHORPE WAY &
 COLLS V2 ALSO CHANGING LANE L ONTO SLIP ROAD. V1 & V2 LEAVE C/WAY O/S & COLLS BARRIER. DRIVER V1
 IMPAIRED BY ALCOHOL.
 Occurred on B4114 NARBOROUGH ROAD SOUTH ENDERBY JW NARBOROUGH ROAD SOUTH SLIP ROAD.

Vehicle Reference 1 Car Changing lane to left
 Not in restricted lane Skidded
 First point of impact Front Age of Driver 23 Breath test Positive
 Vehicle direction S to NW
 FRV Unknown Journey Other/Not known
 Casualty Reference: 1 Age: 23 Male Driver/rider Severity: Serious

Vehicle Reference 2 Car Changing lane to left
 Not in restricted lane Skidded
 First point of impact Back Age of Driver 23 Breath test Negative
 Vehicle direction S to NW
 FRV Unknown Journey Other/Not known
 Casualty Reference: 2 Age: 23 Male Driver/rider Severity: Slight

Casualty Reference: 3 Age: 23 Female Passenger Severity: Slight

Accidents between dates 01/01/2011 and 02/09/2016 (68) months

Selection:

; Refined using Accidents within selected Polygons -Data request polygons ("RPS Enderby 15.09.2016")

Notes:

201500457 21/03/2015 Saturday Time 1300 Vehicles 2 Casualties 1 Slight
Fine without high winds Road surface Dry Daylight:
Special Conditions None Road Type Roundabout

V1 TRAV S/E LANE 5 & V2 TRAV S/E LANE 4 LUBBESTORPE WAY ENTER ROUNDABOUT INTENDING TO TURN R TRAV S/W NARBOROUGH ROAD SOUTH. V2 UNFAMILIAR WITH LOCATION & FOLLOWING SAT NAV ENTERS LANE 5 IN FRONT V1 WHICH COLLS O/S V2.

Occurred on B4114 NARBOROUGH ROAD SOUTH ENDERBY ROUNDABOUT JW LUBBESTHORPE WAY.

Vehicle Reference	1	Car	Going ahead
Not in restricted lane			No skidding, jack-knifing or overturning
First point of impact	Front	Age of Driver	49
Vehicle direction	NW to SW	Breath test	Negative
FRV	Unknown	Journey	Other/Not known
Vehicle Reference	2	Car	Going ahead
Not in restricted lane			No skidding, jack-knifing or overturning
First point of impact	Offside	Age of Driver	53
Vehicle direction	NW to SW	Breath test	Negative
FRV	Unknown	Journey	Other/Not known
Casualty Reference:	1	Age:	53
		Male	Driver/rider
			Severity: Slight

201500370 24/03/2015 Tuesday Time 1757 Vehicles 2 Casualties 1 Slight
Fine without high winds Road surface Dry Daylight:
Special Conditions None Road Type Dual carriageway

V1 & V2 STATIONARY TRAV S/E SOAR VALLEY WAY HELD IN TRAFFIC QUEUE. V1 ANTICIPATES V2 AHEAD MOVING OFF WITH TRAFFIC QUEUE & V1 COLLS REAR V2 STILL STATIONARY AHEAD.

Occurred on A563 SOAR VALLEY WAY ENDERBY. APPROX 40M S/E NARBOROUGH ROAD SOUTH.

Vehicle Reference	1	Car	Moving off
Not in restricted lane			No skidding, jack-knifing or overturning
First point of impact	Front	Age of Driver	40
Vehicle direction	NW to SE	Breath test	Negative
FRV	Unknown	Journey	Other/Not known
Vehicle Reference	2	Car	Waiting to go ahead but held up
Not in restricted lane			No skidding, jack-knifing or overturning
First point of impact	Back	Age of Driver	27
Vehicle direction	NW to SE	Breath test	Negative
FRV	Unknown	Journey	Other/Not known
Casualty Reference:	1	Age:	27
		Female	Driver/rider
			Severity: Slight

Accidents between dates 01/01/2011 and 02/09/2016 (68) months

Selection:

; Refined using Accidents within selected Polygons -Data request polygons ("RPS Enderby 15.09.2016")

Notes:

201500663 01/05/2015 Friday Time 0730 Vehicles 2 Casualties 1 Slight
 Fine without high winds Road surface Dry Daylight:
 Special Conditions None Road Type Roundabout
 V2 (VAN) TRAV SE ON BLABY ROAD IN LANE 2 TURNS LEFT TO TRAV NE & COLLS V1
 TRAV SE IN LANE 1. V2 FAILS TO STOP.
 Occurred on B4114 ST JOHNS ENDERBY JW BLABY ROAD (FOXHUNTER)

Vehicle Reference 1 Car Moving off
 Not in restricted lane No skidding, jack-knifing or overturning
 First point of impact Offside Age of Driver 45 Breath test Negative
 Vehicle direction NW to SE
 FRV Unknown Journey Journey as part of work
 Casualty Reference: 1 Age: 45 Female Driver/rider Severity: Slight

Vehicle Reference 2 Goods <= 3.5 tonnes mgw Turning left
 Not in restricted lane No skidding, jack-knifing or overturning
 First point of impact Front Age of Driver Breath test Driver not contacted
 Vehicle direction NW to NE
 FRV Unknown Journey 6

201500867 04/05/2015 Monday Time 2135 Vehicles 2 Casualties 2 Slight
 Raining without high winds Road surface Wet/Damp Darkness: street lights present and lit
 Special Conditions None Road Type Roundabout
 V2 (TAXI) TRAV N/W SOAR VALLEY WAY DISOBEYED RED TRAFFIC LIGHT ENTERS ROUNDABOUT & COLLS V1
 MOVING OFF TRAV S/E NARBOROUGH RD S.
 Occurred on B4114 NARBOROUGH ROAD SOUTH ENDERBY ROUNDABOUT JW SOAR VALLEY WAY.

Vehicle Reference 1 Car Moving off
 Not in restricted lane No skidding, jack-knifing or overturning
 First point of impact Nearside Age of Driver 19 Breath test Not provided (medical)
 Vehicle direction NE to SW
 FRV Unknown Journey Other/Not known
 Casualty Reference: 1 Age: 19 Male Driver/rider Severity: Slight

Casualty Reference: 2 Age: 20 Female Passenger Severity: Slight

Vehicle Reference 2 Taxi Going ahead
 Not in restricted lane No skidding, jack-knifing or overturning
 First point of impact Front Age of Driver 59 Breath test Negative
 Vehicle direction SE to NW
 FRV Unknown Journey Other/Not known

Accidents between dates 01/01/2011 and 02/09/2016 (68) months

Selection:

; Refined using Accidents within selected Polygons -Data request polygons ("RPS Enderby 15.09.2016")

Notes:

201500712 15/05/2015 Friday Time 1720 Vehicles 2 Casualties 1 Slight
 Fine without high winds Road surface Dry Daylight:
 Special Conditions None Road Type Dual carriageway
 V1 TRAV N ON PENMAN WAY TURNS LEFT AT JUNCTION & COLLS V2 (M/CYCLE) TRAV W.
 Occurred on PENMAN WAY ENDERBY JW PENMAN WAY.

Vehicle Reference	1	Car		Turning left
Not in restricted lane				No skidding, jack-knifing or overturning
First point of impact	Front		Age of Driver 33	Breath test Negative
Vehicle direction	S to E			
FRV	Unknown		Journey	Journey as part of work
Vehicle Reference	2	Motorcycle over 50cc and up to 125cc		Going ahead
Not in restricted lane				No skidding, jack-knifing or overturning
First point of impact	Nearside		Age of Driver 23	Breath test Negative
Vehicle direction	E to W			
FRV	Unknown		Journey	Journey as part of work
Casualty Reference:	1	Age: 23	Male	Driver/rider Severity: Slight

201501106 23/07/2015 Thursday Time 0650 Vehicles 2 Casualties 1 Slight
 Fine without high winds Road surface Dry Daylight:
 Special Conditions None Road Type Dual carriageway
 V1 (ARTIC) TRAV N/E LANE 3 CHANGES LANE L AT POINT WHERE THREE LANES MERGE INTO TWO & COLLS O/S V2
 TRAV N/E LANE 2. V2 LEAVES C/WAY O/S & COLLS ROAD SIGN.
 Occurred on B4114 ST JOHNS ENDERBY. APPROX 115M N/E BLABY ROAD.

Vehicle Reference	1	Goods >= 7.5 tonnes mgw		Changing lane to left
Not in restricted lane				Skidded
First point of impact	Nearside		Age of Driver 28	Breath test Negative
Vehicle direction	SW to NE			
FRV	Unknown		Journey	Journey as part of work
Vehicle Reference	2	Car		Going ahead
Not in restricted lane				Skidded
First point of impact	Offside		Age of Driver 60	Breath test Negative
Vehicle direction	SW to NE			
FRV	Unknown		Journey	Commuting to/from work
Casualty Reference:	1	Age: 59	Female	Passenger Severity: Slight

Accidents between dates 01/01/2011 and 02/09/2016 (68) months

Selection:

; Refined using Accidents within selected Polygons -Data request polygons ("RPS Enderby 15.09.2016")

Notes:

201501210 09/08/2015 Sunday Time 1005 Vehicles 2 Casualties 1 Slight
Fine without high winds Road surface Dry Daylight:
Special Conditions None Road Type Roundabout

V1 TRAV S/W NARBOROUGH RD S MOVES OFF ENTERING ROUNDABOUT INTENDING TO TURN R TRAV N/W TOWARDS M69 & V2 MOVING OFF TRAV S/E ON ROUNDABOUT FROM LUBBESTHORPE WAY ONTO SOAR VALLEY WAY COLLS MID JCT. BOTH PARTIES CLAIMED GREEN TRAFFIC LIGHT IN THEIR FAVO

Occurred on B4114 NARBOROUGH ROAD SOUTH ENDERBY ROUNDABOUT JW LUBBESTHORPE WAY.

Vehicle Reference	1	Car			Moving off
					No skidding, jack-knifing or overturning
Not in restricted lane					
First point of impact	Front		Age of Driver	52	Breath test Negative
Vehicle direction	NE to NW				
FRV	Unknown				Journey Other/Not known
Vehicle Reference	2	Car			Moving off
					No skidding, jack-knifing or overturning
Not in restricted lane					
First point of impact	Nearside		Age of Driver	30	Breath test Not requested
Vehicle direction	NW to SE				
FRV	Unknown				Journey Other/Not known
Casualty Reference:	1	Age:	30	Male	Driver/rider Severity: Slight

201501340 25/08/2015 Tuesday Time 0006 Vehicles 2 Casualties 2 Slight
Fine without high winds Road surface Wet/Damp Darkness: street lights present and lit
Special Conditions None Road Type Roundabout

V1 TRAV N/W LANE 1 SOAR VALLEY WAY DISOBEYED RED TRAFFIC LIGHT ENTERS ROUNDABOUT IN FRONT V2 TRAV S/W NARBOROUGH RD S. V2 UNABLE TO AVOID V1 COLLS O/S V1.

Occurred on B4114 NARBOROUGH ROAD SOUTH ENDERBY ROUNDABOUT JW SOAR VALLEY WAY.

Vehicle Reference	1	Car			Going ahead
					No skidding, jack-knifing or overturning
Not in restricted lane					
First point of impact	Offside		Age of Driver	33	Breath test Negative
Vehicle direction	SE to NW				
FRV	Unknown				Journey Other/Not known
Casualty Reference:	1	Age:	33	Male	Driver/rider Severity: Slight

Vehicle Reference	2	Car			Going ahead
					No skidding, jack-knifing or overturning
Not in restricted lane					
First point of impact	Front		Age of Driver	23	Breath test Negative
Vehicle direction	NE to SW				
FRV	Unknown				Journey Other/Not known
Casualty Reference:	2	Age:	23	Male	Driver/rider Severity: Slight

Accidents between dates 01/01/2011 and 02/09/2016 (68) months

Selection:

; Refined using Accidents within selected Polygons -Data request polygons ("RPS Enderby 15.09.2016")

Notes:

201501465 08/09/2015 Tuesday Time 0640 Vehicles 2 Casualties 1 Slight
Fine without high winds Road surface Wet/Damp Daylight:
Special Conditions None Road Type Single carriageway
V2 STATIONARY TRAV S/W TRINITY RD MOVES OFF TURNING R TRAV N/W & COLLS V1 (M/CYCLE) TRAV S/E ENDERBY RD.
Occurred on B582 ENDERBY ROAD ENDERBY JW TRINITY ROAD.

Vehicle Reference 1 Motorcycle over 500cc Going ahead
Not in restricted lane No skidding, jack-knifing or overturning
First point of impact Nearside Age of Driver 50 Breath test Not requested
Vehicle direction NW to SE
FRV Unknown Journey 6
Casualty Reference: 1 Age: 50 Male Driver/rider Severity: Slight

Vehicle Reference 2 Car Turning right
Not in restricted lane No skidding, jack-knifing or overturning
First point of impact Front Age of Driver 37 Breath test Negative
Vehicle direction NE to NW
FRV Unknown Journey 6

201501524 14/09/2015 Monday Time 0950 Vehicles 1 Casualties 1 Slight
Fine without high winds Road surface Wet/Damp Daylight:
Special Conditions None Road Type Single carriageway
V1 LOSES CONTROL LEAVING ROUNDABOUT NEG L BEND CONT TRAV S/E BLABY RD COLLS BOLLARD REFUGE LEAVES C/WAY O/S & COLLS TELEGRAPH POLE.
Occurred on B582 BLABY ROAD ENDERBY JW TRINITY ROAD.

Vehicle Reference 1 Car Going ahead left hand bend
Not in restricted lane Skidded
First point of impact Offside Age of Driver 24 Breath test Negative
Vehicle direction NE to SE
FRV Unknown Journey Other/Not known
Casualty Reference: 1 Age: 24 Female Passenger Severity: Slight

Accidents between dates 01/01/2011 and 02/09/2016 (68) months

Selection: Notes:

; Refined using Accidents within selected Polygons -Data request polygons ("RPS Enderby 15.09.2016")

201501547 26/09/2015 Saturday Time 0726 Vehicles 2 Casualties 1 Slight
Fine without high winds Road surface Dry Daylight:
Special Conditions None Road Type Dual carriageway
V1 & V2 TRAV N/W LANE 3 SOAR VALLEY WAY. V2 AHEAD BRAKES & V1 COLLS REAR V2.
Occurred on A563 SOAR VALLEY WAY JW ROUNDABOUT NARBOROUGH ROAD SOUTH.

Vehicle Reference 1 Car Going ahead
Not in restricted lane No skidding, jack-knifing or overturning
First point of impact Front Age of Driver 30 Breath test Negative
Vehicle direction SE to NW
FRV Unknown Journey Other/Not known
Casualty Reference: 1 Age: 12 Male Passenger Severity: Slight

Vehicle Reference 2 Car Slowing or Stopping
Not in restricted lane No skidding, jack-knifing or overturning
First point of impact Back Age of Driver 38 Breath test Negative
Vehicle direction SE to NW
FRV Unknown Journey Commuting to/from work

Accidents between dates 01/01/2011 and 02/09/2016 (68) months

Selection:

; Refined using Accidents within selected Polygons -Data request polygons ("RPS Enderby 15.09.2016")

Notes:

201501730 14/10/2015 Wednesday Time 2030 Vehicles 3 Casualties 2 Slight
Raining without high winds Road surface Wet/Damp Darkness: street lights present and lit
Special Conditions None Road Type Roundabout
V1 TRAV N/W SOAR VALLEY WAY MOVES OFF ENTERING ROUNDABOUT & COLLS N/S V2 & FRONT V3 MOVING OFF
TRAV S/W ON ROUNDABOUT NARBOROUGH RD S. ALL DRIVERS CLAIMED GREEN TRAFFIC LIGHT IN THEIR FAVOUR.
Occurred on B4114 NARBOROUGH ROAD SOUTH ENDERBY ROUNDABOUT JW SOAR VALLEY WAY.

Vehicle Reference 1 Car Moving off
Not in restricted lane No skidding, jack-knifing or overturning
First point of impact Offside Age of Driver 39 Breath test Negative
Vehicle direction SE to NW
FRV Unknown Journey 6
Casualty Reference: 1 Age: 39 Male Driver/rider Severity: Slight

Vehicle Reference 2 Car Moving off
Not in restricted lane No skidding, jack-knifing or overturning
First point of impact Front Age of Driver 18 Breath test Negative
Vehicle direction NE to SW
FRV Unknown Journey 6
Casualty Reference: 2 Age: 18 Male Driver/rider Severity: Slight

Vehicle Reference 3 Car Moving off
Not in restricted lane No skidding, jack-knifing or overturning
First point of impact Front Age of Driver 68 Breath test Negative
Vehicle direction NE to SW
FRV Unknown Journey 6

Accidents between dates 01/01/2011 and 02/09/2016 (68) months

Selection:

; Refined using Accidents within selected Polygons -Data request polygons ("RPS Enderby 15.09.2016")

Notes:

201501584 27/10/2015 Tuesday Time 1706 Vehicles 2 Casualties 1 Slight
 Fine without high winds Road surface Dry Daylight:
 Special Conditions None Road Type Dual carriageway
 V1 & V2 TRAV S/W ST JOHNS IN HEAVY SLOW MOVING TRAFFIC. V2 AHEAD STOPS & V1 COLLS REAR V2. V1 HIT & RUN.
 OUTSTANDING POLICE QUERY.
 Occurred on B4114 ST JOHNS ENDERBY. EXACT LOCATION UNKNOWN.

Vehicle Reference 1 Car Going ahead
 Not in restricted lane No skidding, jack-knifing or overturning
 First point of impact Front Age of Driver Breath test Driver not contacted
 Vehicle direction NE to SW
 FRV Unknown Journey 6

Vehicle Reference 2 Car Waiting to go ahead but held up
 Not in restricted lane No skidding, jack-knifing or overturning
 First point of impact Back Age of Driver 57 Breath test Driver not contacted
 Vehicle direction NE to SW
 FRV Unknown Journey 6

Casualty Reference: 1 Age: 57 Female Driver/rider Severity: Slight

201501867 30/10/2015 Friday Time 1744 Vehicles 2 Casualties 1 Slight
 Fine without high winds Road surface Wet/Damp Daylight:
 Special Conditions None Road Type Single carriageway
 V1 TURNS RIGHT FROM BUILDERS YARD THROUGH LINE OF STATIONARY TRAFFIC & COLLS V2 (M/CYCLE) TRAV NW
 OVERTAKING QUEUE.
 Occurred on B582 MILL HILL ENDERBY AT ENTRANCE TO BUILDERS YARD.

Vehicle Reference 1 Car Turning right
 Not in restricted lane No skidding, jack-knifing or overturning
 First point of impact Offside Age of Driver 53 Breath test Not requested
 Vehicle direction SW to SE
 FRV Unknown Journey Commuting to/from work

Vehicle Reference 2 Car Going ahead
 Not in restricted lane Skidded
 First point of impact Front Age of Driver 22 Breath test Not requested
 Vehicle direction SE to NW
 FRV Unknown Journey Commuting to/from work

Casualty Reference: 1 Age: 22 Male Driver/rider Severity: Slight

Accidents between dates 01/01/2011 and 02/09/2016 (68) months

Selection:

; Refined using Accidents within selected Polygons -Data request polygons ("RPS Enderby 15.09.2016")

Notes:

201502095 10/12/2015 Thursday Time 1154 Vehicles 2 Casualties 1 Slight
 Raining without high winds Road surface Wet/Damp Daylight:
 Special Conditions None Road Type Roundabout
 V1 TRAV S/E LANE 2 BLABY ROAD FAILS TO GIVE WAY ENTERS ROUNDABOUT & COLLS N/S V2 TRAV N/E LEICESTER RD ON ROUNDABOUT.
 Occurred on B4114 LEICESTER ROAD ENDERBY ROUNDABOUT JW BLABY ROAD.

Vehicle Reference 1 Car Going ahead
 Not in restricted lane Skidded
 First point of impact Front Age of Driver 28 Breath test Not provided (medical)
 Vehicle direction NW to SE
 FRV Unknown Journey 6
 Casualty Reference: 1 Age: 28 Male Driver/rider Severity: Slight

Vehicle Reference 2 Car Going ahead
 Not in restricted lane Skidded
 First point of impact Nearside Age of Driver 80 Breath test Negative
 Vehicle direction SW to NE
 FRV Unknown Journey 6

201502082 20/12/2015 Sunday Time 1824 Vehicles 2 Casualties 2 Slight
 Fine without high winds Road surface Wet/Damp Darkness: street lights present and lit
 Special Conditions None Road Type Roundabout
 V2 TRAV S/E LUBBESTHORPE WAY DISOBEYED TRAFFIC LIGHT TRAV AHEAD ONTO SOAR VALLEY WAY & COLLS V1 TRAV N/E ON ROUNDABOUT NARBOROUGH RD SOUTH.
 Occurred on B4114 NARBOROUGH ROAD SOUTH ENDERBY ROUNDABOUT JW LUBBESTHORPE WAY.

Vehicle Reference 1 Car Going ahead
 Not in restricted lane No skidding, jack-knifing or overturning
 First point of impact Nearside Age of Driver 53 Breath test Negative
 Vehicle direction SW to NE
 FRV Unknown Journey 6
 Casualty Reference: 1 Age: 53 Female Driver/rider Severity: Slight

Vehicle Reference 2 Car Going ahead
 Not in restricted lane No skidding, jack-knifing or overturning
 First point of impact Front Age of Driver 72 Breath test Negative
 Vehicle direction NW to SE
 FRV Unknown Journey 6
 Casualty Reference: 2 Age: 72 Female Driver/rider Severity: Slight

Accidents between dates 01/01/2011 and 02/09/2016 (68) months

Selection:

; Refined using Accidents within selected Polygons -Data request polygons ("RPS Enderby 15.09.2016")

Notes:

201505810 24/12/2015 Thursday Time 1121 Vehicles 1 Casualties 1 Serious
 Fine without high winds Road surface Dry Daylight:
 Special Conditions None Road Type Single carriageway
 STATS 19 FORM NOT RECEIVED.
 Occurred on C3603 LEICESTER LANE ENDERBY JW ST JOHNS.

Vehicle Reference 1 Car Turning left
 Not in restricted lane No skidding, jack-knifing or overturning
 First point of impact Did not impact Age of Driver 44 Breath test Negative
 Vehicle direction E to N
 FRV Unknown Journey 6
 Casualty Reference: 1 Age: 86 Female Pedestrian Severity: Serious
 9

201600045 05/01/2016 Tuesday Time 1903 Vehicles 2 Casualties 3 Slight
 Raining without high winds Road surface Wet/Damp Darkness: street lights present and lit
 Special Conditions None Road Type Roundabout
 V1 TRAV N/W LANE 2 SOAR VALLEY WAY. TRAFFIC LIGHTS TURN TO RED. V1 DISOBEYED RED TRAFFIC LIGHT ENTERS
 ROUNDABOUT & COLLS V2 MOVING OFF WITH GREEN TRAFFIC LIGHT TRAV S/W ON ROUNDABOUT NARBOROUGH RD
 SOUTH.
 Occurred on B4114 NARBOROUGH ROAD SOUTH ENDERBY ROUNDABOUT JW SOAR VALLEY WAY.

Vehicle Reference 1 Car Going ahead
 Not in restricted lane No skidding, jack-knifing or overturning
 First point of impact Offside Age of Driver 47 Breath test Not provided (medical)
 Vehicle direction SE to NW
 FRV Unknown Journey Commuting to/from work
 Casualty Reference: 1 Age: 47 Female Driver/rider Severity: Slight

Vehicle Reference 2 Car Moving off
 Not in restricted lane No skidding, jack-knifing or overturning
 First point of impact Front Age of Driver 53 Breath test Not provided (medical)
 Vehicle direction NE to SW
 FRV Unknown Journey Commuting to/from work
 Casualty Reference: 2 Age: 53 Male Driver/rider Severity: Slight

Casualty Reference: 3 Age: 47 Female Passenger Severity: Slight

Accidents between dates 01/01/2011 and 02/09/2016 (68) months

Selection:

; Refined using Accidents within selected Polygons -Data request polygons ("RPS Enderby 15.09.2016")

Notes:

201600534 15/01/2016 Friday Time 0946 Vehicles 2 Casualties 1 Slight
Fine without high winds Road surface Dry Daylight:
Special Conditions None Road Type Roundabout
V2 TRAV N/E LANE 2 NARBOROUGH RD SOUTH DISOBEYED RED TRAFFIC LIGHT AND COLLS V1 TRAV N/W LANE 3
SOAR VALLEY WAY ONTO LUBBESTHORPE WAY.
Occurred on B4114 NARBOROUGH ROAD SOUTH ROUNDABOUT JW SOAR VALLEY WAY.

Vehicle Reference 1 Car Going ahead
Not in restricted lane No skidding, jack-knifing or overturning
First point of impact Nearside Age of Driver 21 Breath test Negative
Vehicle direction SE to NW
FRV Unknown Journey 6
Casualty Reference: 1 Age: 21 Male Driver/rider Severity: Slight

Vehicle Reference 2 Car Going ahead
Not in restricted lane No skidding, jack-knifing or overturning
First point of impact Front Age of Driver 56 Breath test Negative
Vehicle direction SW to NE
FRV Unknown Journey 6

201600530 31/03/2016 Thursday Time 0337 Vehicles 1 Casualties 1 Serious
Fine without high winds Road surface Dry Darkness: street lights present and lit
Special Conditions None Road Type Dual carriageway
V1 TRAV N/W LUBBESTHORPE WAY COLLS KERB LEAVES C/WAY N/S & COLLS CONCRETE BASE OF TRAFFIC LIGHT.
Occurred on A563 LUBBESTHORPE WAY ENDERBY JW PENMAN WAY. APPROX 80M N/W NARBOROUGH RD

Vehicle Reference 1 Car Going ahead
Not in restricted lane No skidding, jack-knifing or overturning
First point of impact Offside Age of Driver 25 Breath test Not provided (medical)
Vehicle direction SE to NW
FRV Unknown Journey 6
Casualty Reference: 1 Age: 25 Male Driver/rider Severity: Serious

Accidents between dates 01/01/2011 and 02/09/2016 (68) months

Selection:

; Refined using Accidents within selected Polygons -Data request polygons ("RPS Enderby 15.09.2016")

Notes:

201600619 15/04/2016 Friday Time 0923 Vehicles 2 Casualties 1 Slight
 Raining without high winds Road surface Wet/Damp Daylight:
 Special Conditions None Road Type Roundabout
 V2 TRAV S ON NARBOROUGH ROAD SOUTH ENTERS ROUNDABOUT & COLLS V1 TRAV E.
 UNKNOWN WHICH VEHICLE DISOBEYED SIGNALS.
 Occurred on B4114 NARBOROUGH ROAD SOUTH ENDERBY JW SOAR VALLEY WAY.

Vehicle Reference	1	Car		Changing lane to left
				No skidding, jack-knifing or overturning
First point of impact	Nearside		Age of Driver	45
Vehicle direction	W to E		Breath test	Not requested
FRV	Unknown		Journey	Journey as part of work
Vehicle Reference	2	Taxi		Going ahead
				Skidded
First point of impact	Offside		Age of Driver	55
Vehicle direction	N to S		Breath test	Not requested
FRV	Unknown		Journey	Journey as part of work
Casualty Reference:	1	Age: 51	Female	Passenger
				Severity: Slight

201600821 16/05/2016 Monday Time 2157 Vehicles 2 Casualties 1 Slight
 Fine without high winds Road surface Dry Darkness: street lights present and lit
 Special Conditions None Road Type Dual carriageway
 V2 TRAV S/W ST JOHNS UNDERTAKES WITNESS VEHICLE BEFORE CHANGING LANE R. V1 SLOWS BUT FAILS TO STOP
 IN TIME & COLLS REAR V1 HELD AT ROUNABOUT. V2 HIT & RUN.
 Occurred on B4114 ST JOHNS ENDERBY JW ROUNDABOUT BLABY ROAD.

Vehicle Reference	1	Car		Waiting to go ahead but held up
				No skidding, jack-knifing or overturning
First point of impact	Back		Age of Driver	22
Vehicle direction	NE to SW		Breath test	Negative
FRV	Unknown		Journey	6
Casualty Reference:	1	Age: 22	Male	Driver/rider
				Severity: Slight

Vehicle Reference	2	Car		Slowing or Stopping
				Skidded
First point of impact	Front		Age of Driver	Breath test
Vehicle direction	NE to SW			Driver not contacted
FRV	Unknown		Journey	6

Accidents between dates 01/01/2011 and 02/09/2016 (68) months

Selection: Notes:
; Refined using Accidents within selected Polygons -Data request
polygons ("RPS Enderby 15.09.2016")

201600820 17/05/2016 Tuesday Time 1104 Vehicles 2 Casualties 1 Slight
Fine without high winds Road surface Dry Daylight:
Special Conditions None Road Type Dual carriageway
V1 & V2 SLOWING FOR TRAFFIC LIGHTS AHEAD TRAV S/E LANE 1 LUBBESTHORPE RD & V2 COLLS REAR V1.
Occurred on A563 LUBBESTHORPE WAY ENDERBY JW ROUNDABOUT NARBOROUGH ROAD SOUTH.

Vehicle Reference 1 Car Slowing or Stopping
Not in restricted lane No skidding, jack-knifing or overturning
First point of impact Back Age of Driver 30 Breath test Negative
Vehicle direction NW to SE
FRV Unknown Journey Journey as part of work
Casualty Reference: 1 Age: 30 Male Driver/rider Severity: Slight

Vehicle Reference 2 Car Slowing or Stopping
Not in restricted lane No skidding, jack-knifing or overturning
First point of impact Front Age of Driver 37 Breath test Negative
Vehicle direction NW to SE
FRV Unknown Journey Journey as part of work

201601128 03/07/2016 Sunday Time 1100 Vehicles 2 Casualties 2 Slight
Fine without high winds Road surface Dry Daylight:
Special Conditions None Road Type Roundabout
V2 TRAV SE FROM ENDERBY FAILS TO GIVE WAY AT ROUNDABOUT TURNING L ONTO ST JOHNS & COLLS V1 TRAV NE.
Occurred on B4114 ST JOHNS ENDERBY AT EXIT FROM FOXHUNTER ROUNDABOUT.

Vehicle Reference 1 Car Going ahead
Not in restricted lane No skidding, jack-knifing or overturning
First point of impact Nearside Age of Driver 50 Breath test Not requested
Vehicle direction SW to NE
FRV Unknown Journey 6
Casualty Reference: 1 Age: 10 Male Passenger Severity: Slight

Vehicle Reference 2 Car Turning left
Not in restricted lane No skidding, jack-knifing or overturning
First point of impact Offside Age of Driver 56 Breath test Not requested
Vehicle direction NW to NE
FRV Unknown Journey 6
Casualty Reference: 2 Age: 56 Female Driver/rider Severity: Slight

Accidents between dates 01/01/2011 and 02/09/2016 (68) months

Selection:

; Refined using Accidents within selected Polygons -Data request polygons ("RPS Enderby 15.09.2016")

Notes:

201601221 06/07/2016 Wednesday Time 1856 Vehicles 2 Casualties 3 Slight
Fine without high winds Road surface Dry Daylight:
Special Conditions None Road Type Roundabout
V1 TRAV SE ON LUBBESTHORPE WAY FAILS TO STOP AT RED SIGNAL & COLLS V2 TRAV NE ON NARBOROUGH ROAD SOUTH.
Occurred on B4114 NARBOROUGH ROAD SOUTH ENDERBYJW LUBBESTHORPE WAY.

Vehicle Reference 1 Car Going ahead
Not in restricted lane No skidding, jack-knifing or overturning
First point of impact Front Age of Driver 35 Breath test Negative
Vehicle direction NW to SE
FRV Unknown Journey Other/Not known
Casualty Reference: 1 Age: 35 Female Driver/rider Severity: Slight

Vehicle Reference 2 Car Going ahead
Not in restricted lane No skidding, jack-knifing or overturning
First point of impact Nearside Age of Driver 58 Breath test Negative
Vehicle direction SW to NE
FRV Unknown Journey Other/Not known
Casualty Reference: 2 Age: 58 Male Driver/rider Severity: Slight

Casualty Reference: 3 Age: 15 Male Passenger Severity: Slight

201601142 08/07/2016 Friday Time 1500 Vehicles 2 Casualties 1 Slight
Fine without high winds Road surface Dry Daylight:
Special Conditions None Road Type Roundabout
V1 (M/CYCLE) TRAV SE ON LUBBESTHORPE WAY FAILS TO STOP AT RED SIGNAL & COLLS V2 TRAV SW ON NARBOROUGH ROAD SOUTH.
Occurred on A563 LUBBESTHORPE WAY ENDERBY JW NARBOROUGH ROAD SOUTH.

Vehicle Reference 1 Motorcycle over 125cc and up to 500cc Going ahead
Not in restricted lane No skidding, jack-knifing or overturning
First point of impact Front Age of Driver 54 Breath test Negative
Vehicle direction NW to SE
FRV Unknown Journey Other/Not known
Casualty Reference: 1 Age: 54 Male Driver/rider Severity: Slight

Vehicle Reference 2 Car Going ahead
Not in restricted lane No skidding, jack-knifing or overturning
First point of impact Offside Age of Driver 24 Breath test Negative
Vehicle direction NE to SW
FRV Unknown Journey Other/Not known

Accidents between dates **01/01/2011 and 02/09/2016** (68) months

Selection:

; Refined using Accidents within selected Polygons -Data request polygons ("RPS Enderby 15.09.2016")

Notes:

Accidents involving:

	Fatal	Serious	Slight	Total
Motor vehicles only (excluding	0	7	96	103
2-wheeled motor vehicles	0	3	4	7
Pedal cycles	0	2	4	6
Horses & other	0	0	1	1
Total	0	12	104	116

Casualties:

	Fatal	Serious	Slight	Total
Vehicle driver	0	5	104	109
Passenger	0	0	39	39
Motorcycle rider	0	3	4	7
Cyclist	0	2	3	5
Pedestrian	0	2	1	3
Other	0	0	0	0
Total	0	12	151	163



Scale 1:8000

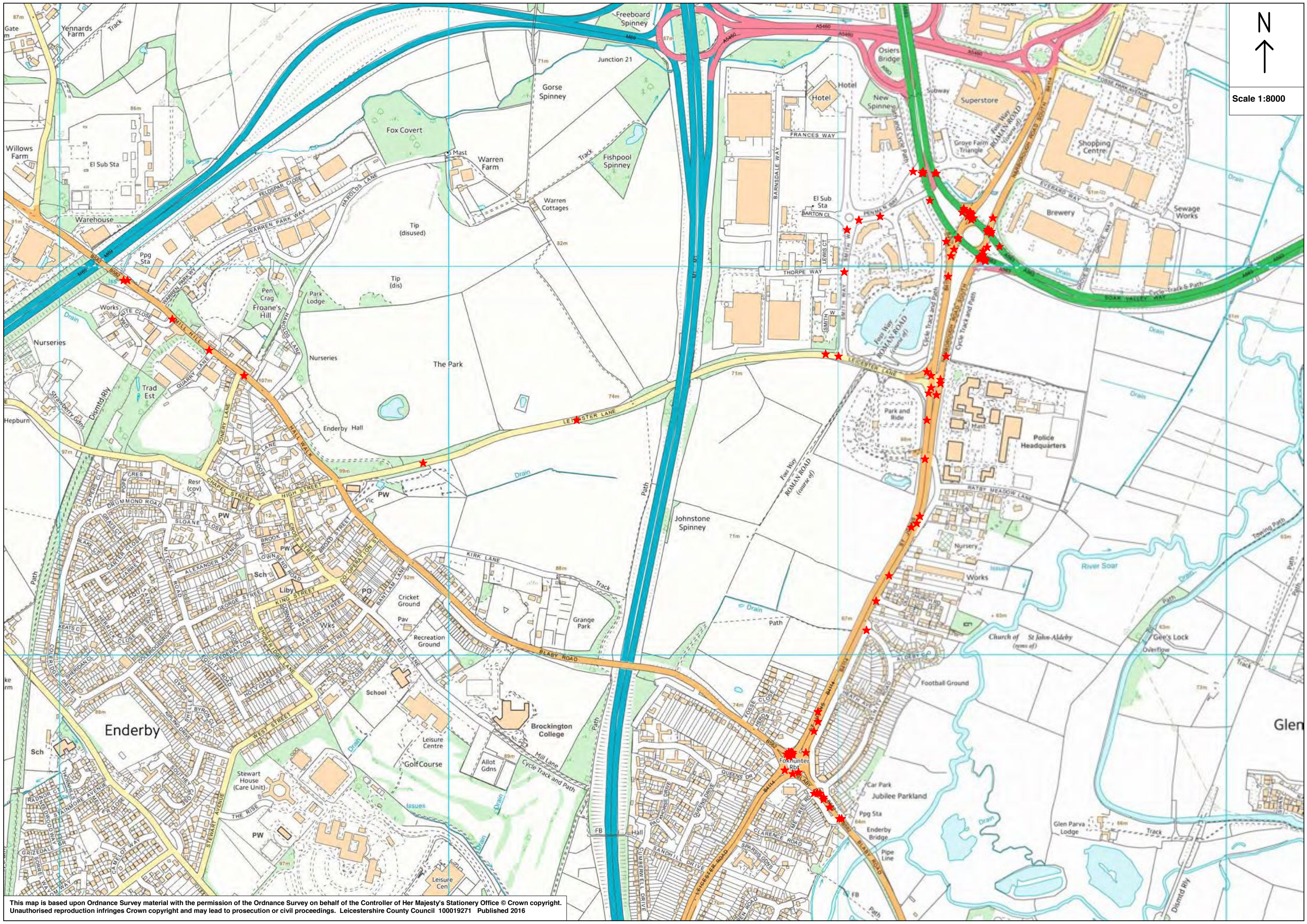

Appendix C – Base Traffic Flows

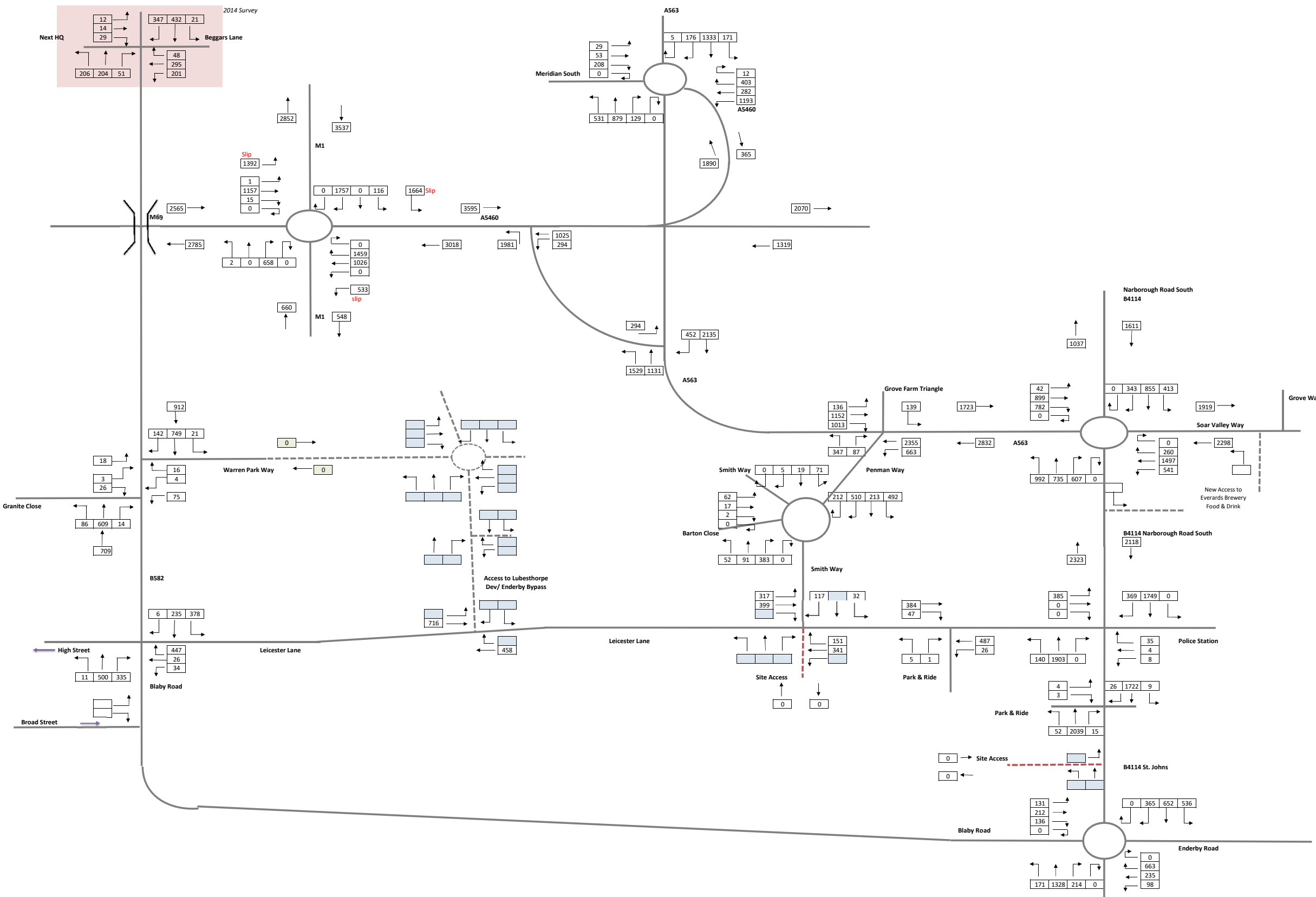

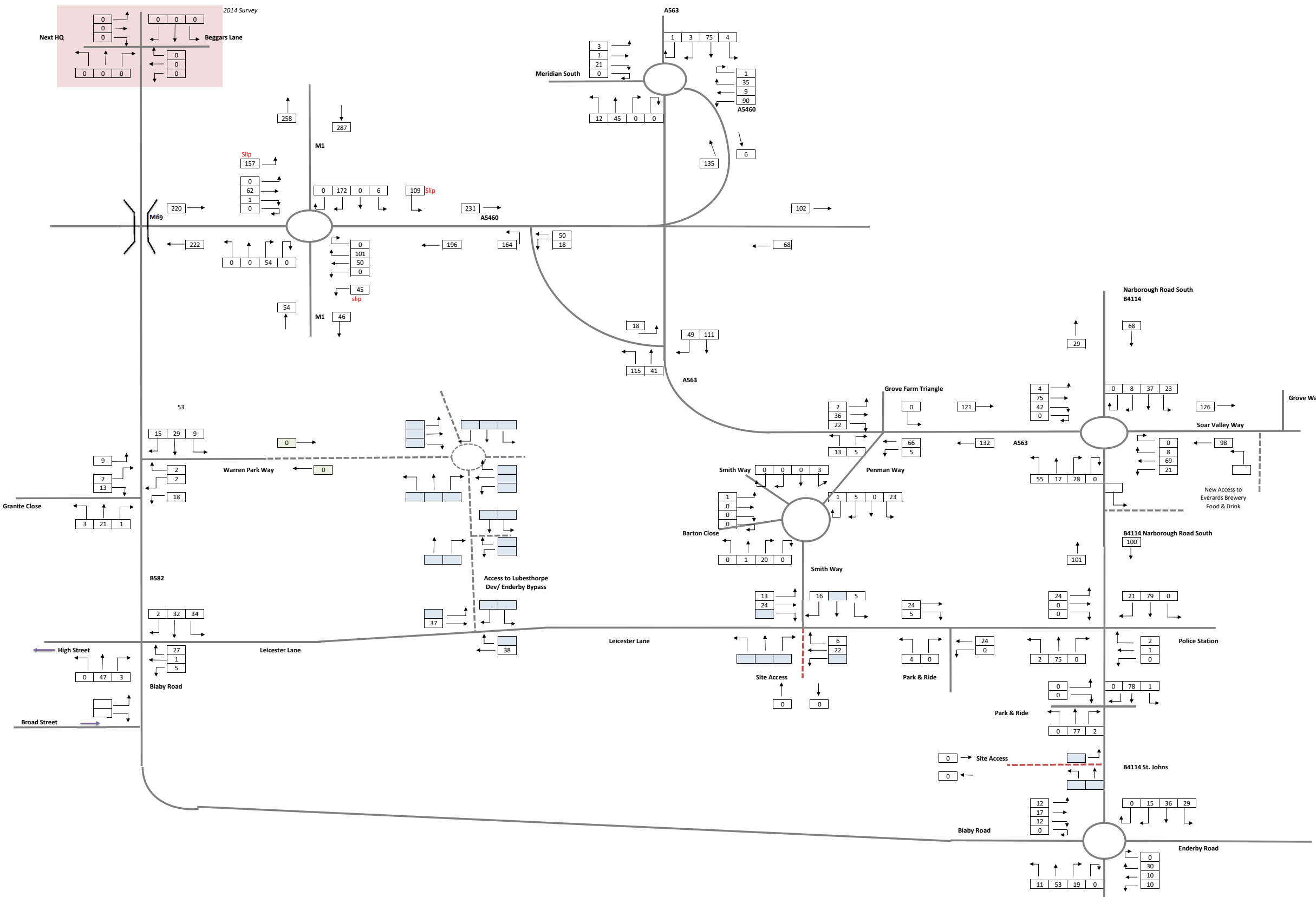

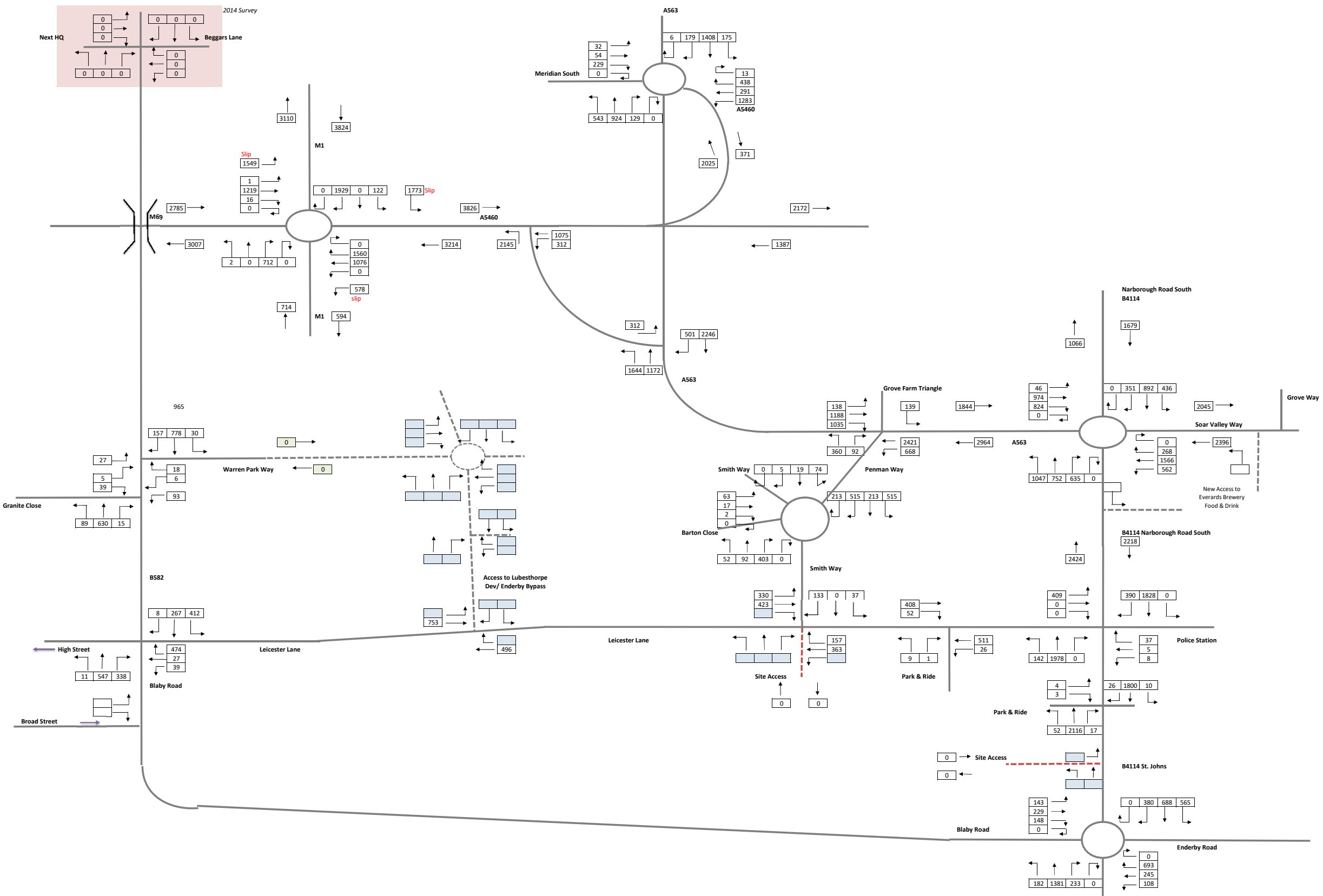

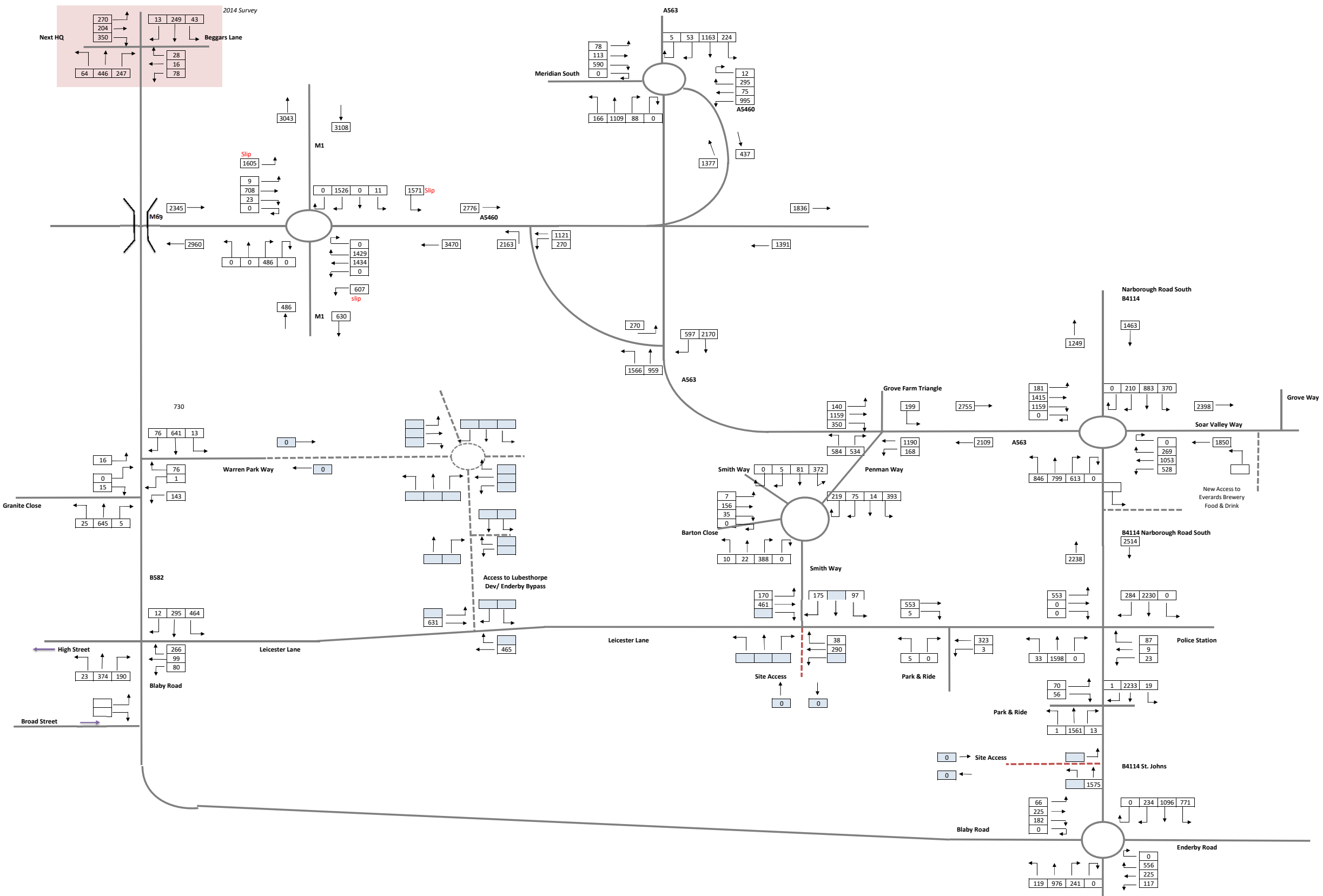

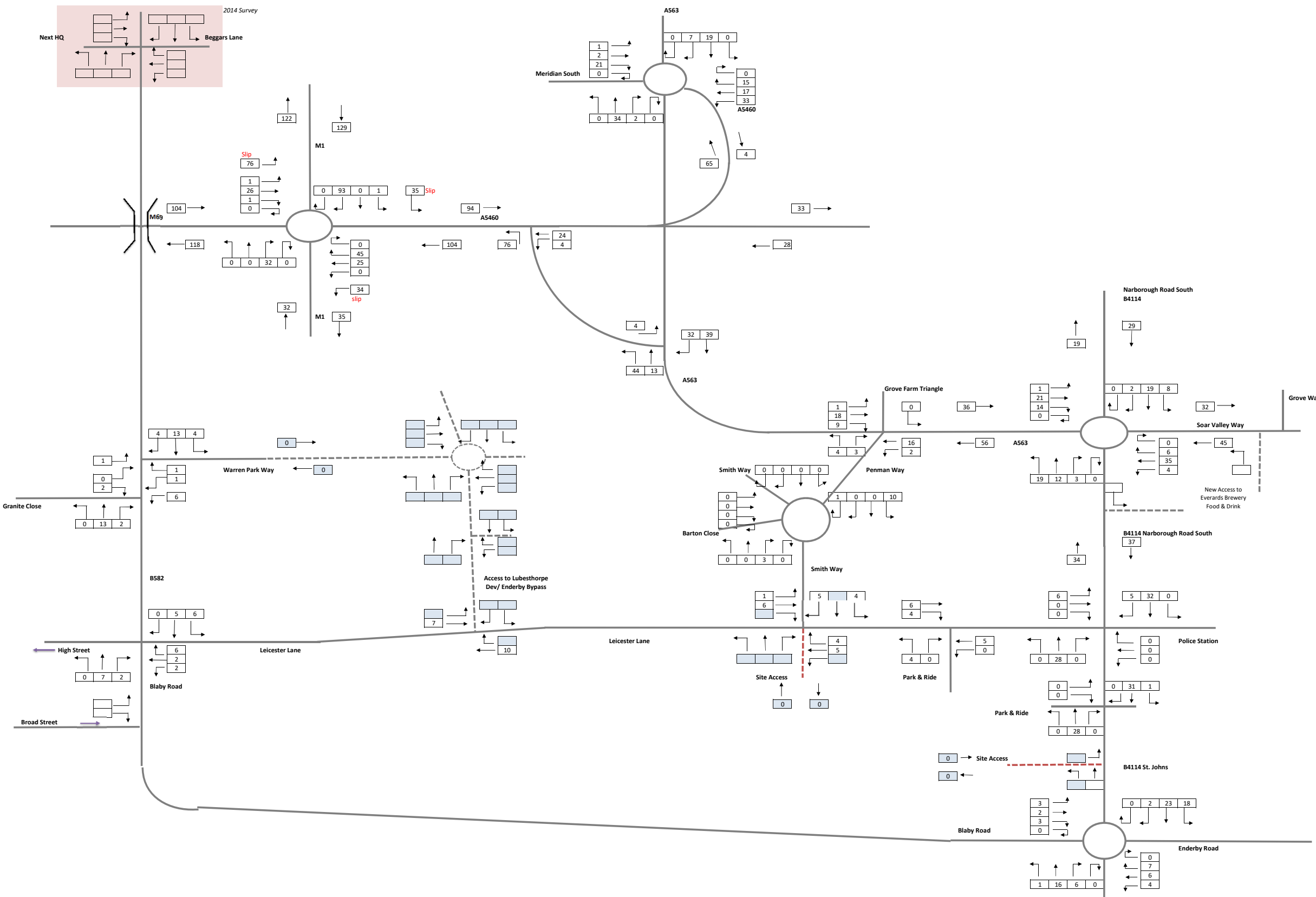

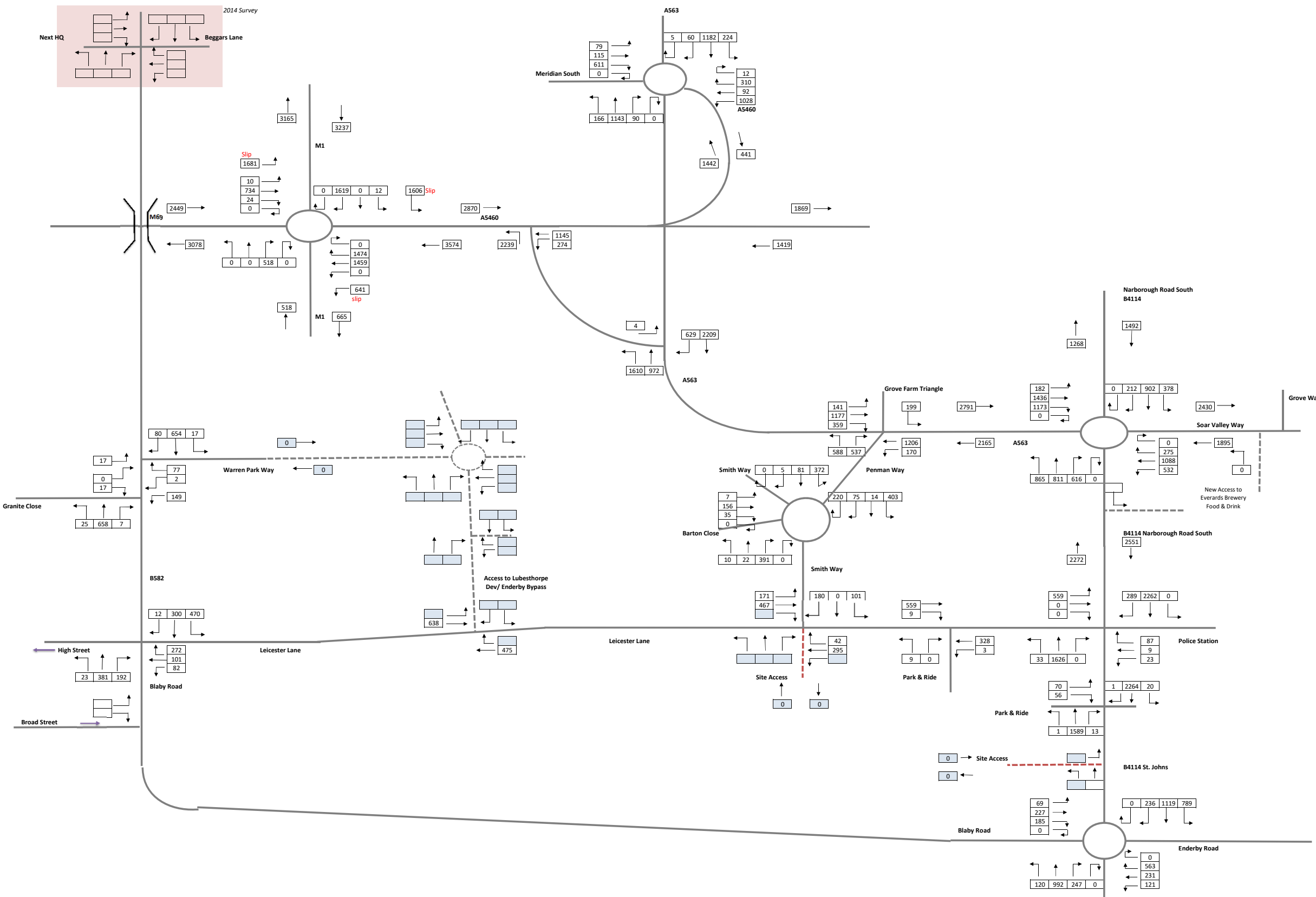

2017 Data	21	12	
2018 Data	11	5	
Next HQ	42	31	

417	450	25
335	355	32

49	63
297	354
228	189

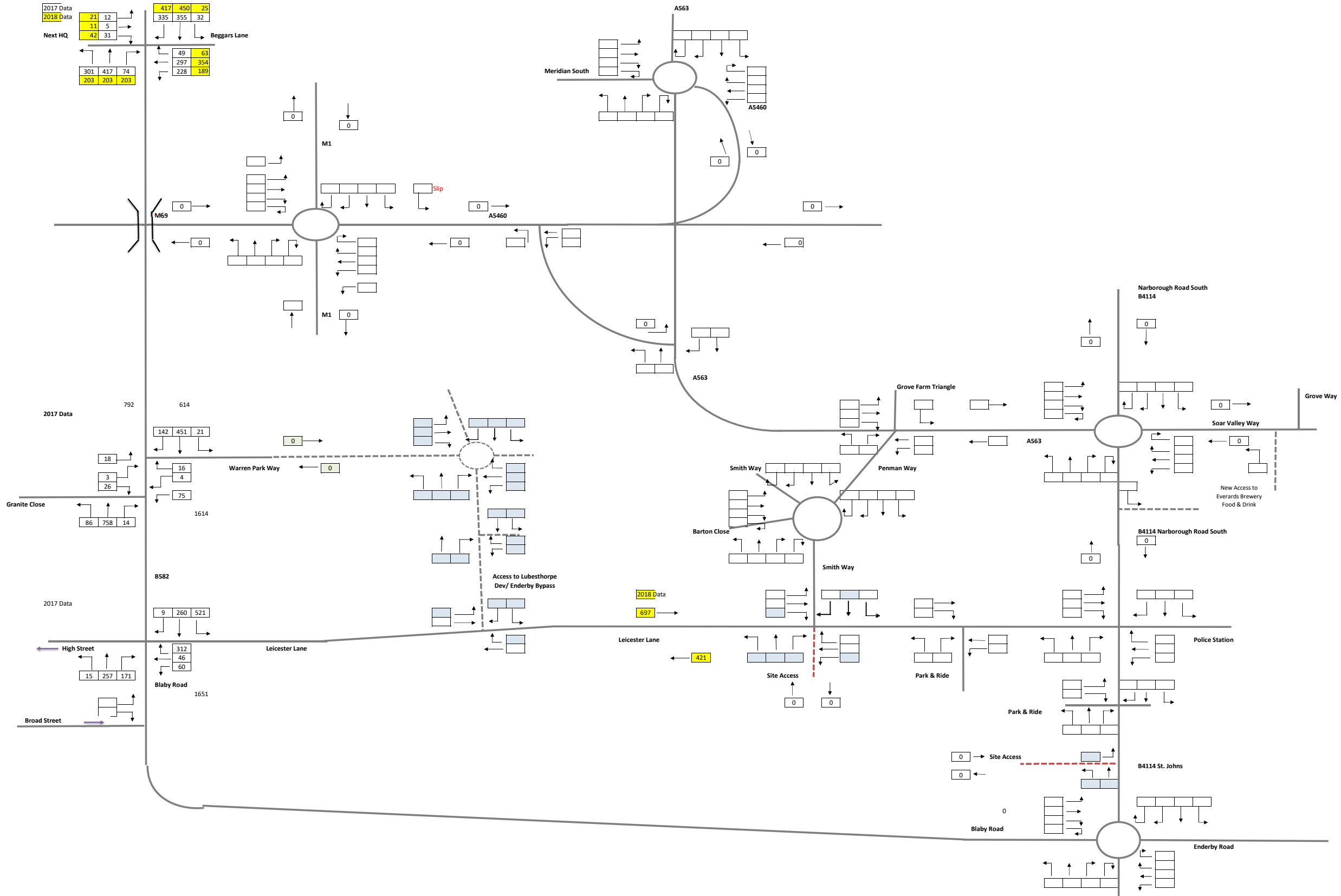

WITH ENDERBY BYPASS

Leicester Lane, Enderby
 JNY 8838
 2017/18 Base Traffic Flows
 AM Peak
 All Vehicles

303	301	13	218	72
240	193	20	317	62
261	209			

2017 Survey
2018 Survey

34	52
15	13
134	75

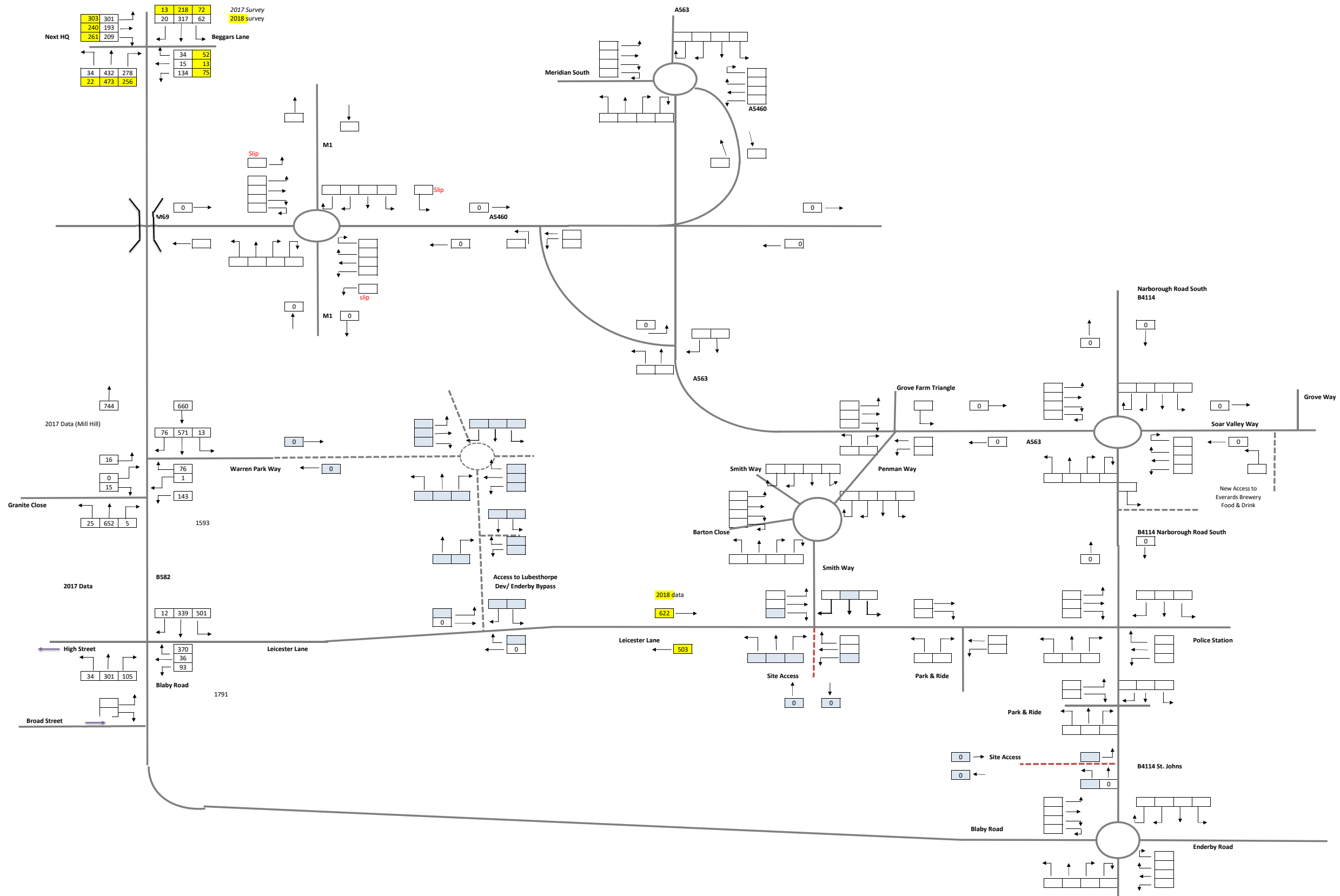

WITH ENDERBY BYPASS

Leicester Lane, Enderby
JNY 8838
2017/18 Base Traffic Flows
PM Peak
All Vehicles

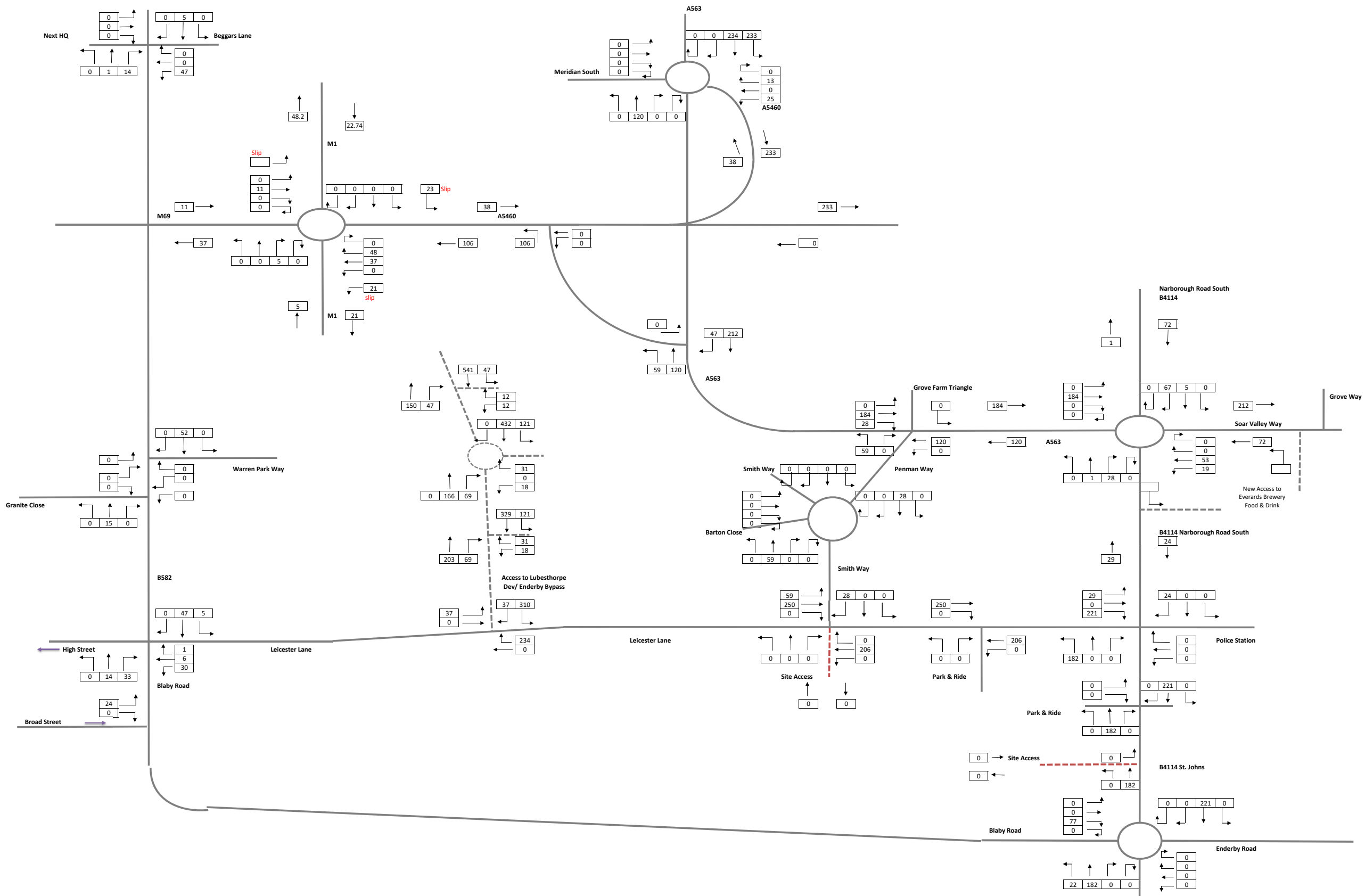

Note: Traffic Movements associated with the Lubbesthorpe Development have been based the traffic flows provided in the original Lubbesthorpe TA.

Lubbesthorpe Development
 100% Employment
 4500 Dwellings
WITH M69 Bridge WITHOUT Enderby Bypass

WITHOUT ENDERBY BYPASS

Leicester Lane, Enderby
 JNY 8838
Full Development of Lubbesthorpe WITH M69 Bridge
Employment & Residential Trips
 AM Peak (08:00 - 09:00)
 PCU's

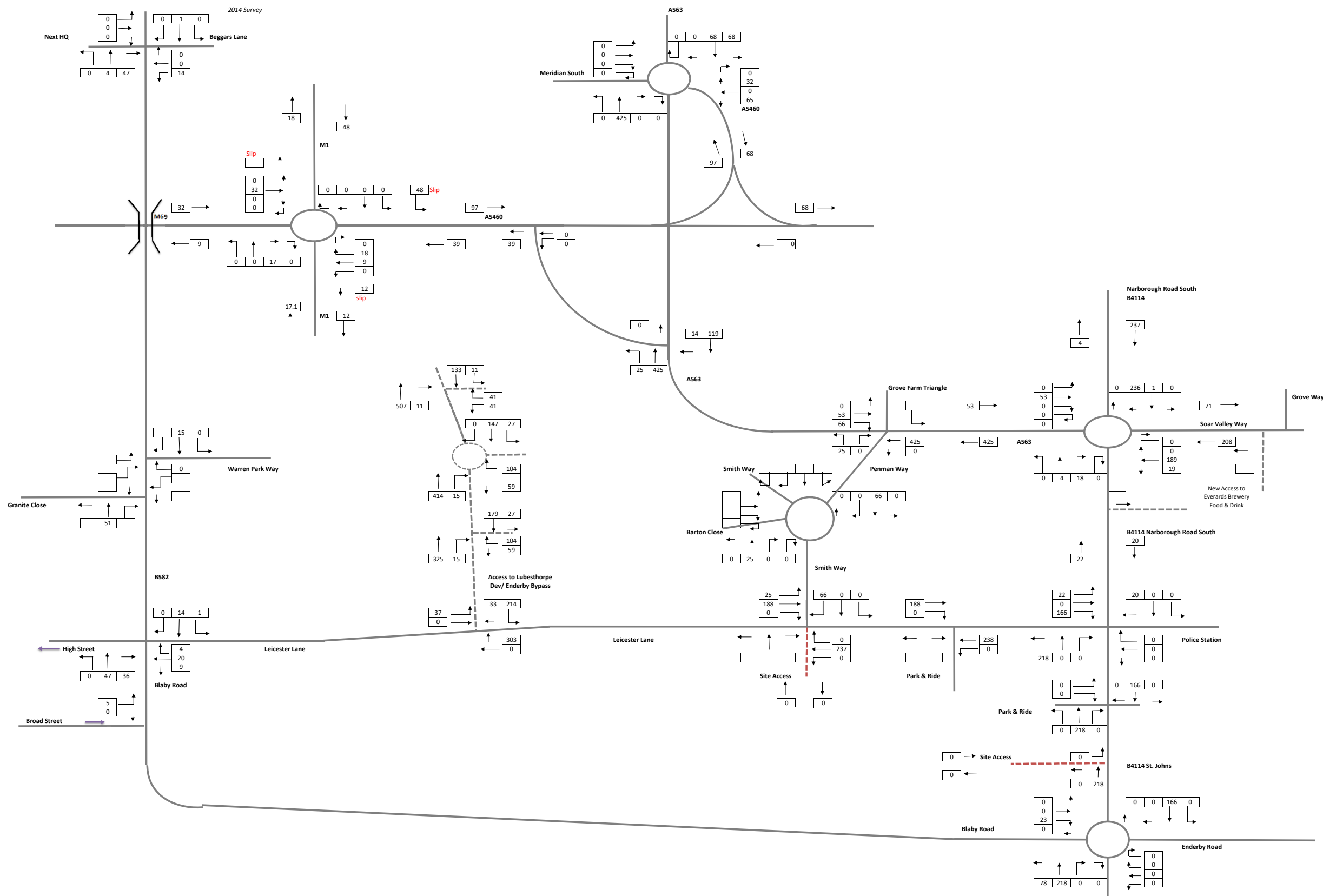

Note: Traffic Movements associated with the Lubbesthorpe Development have been based on the traffic flows provided in the original Lubbesthorpe TA.

Lubbesthorpe Development
 100% Employment
 4500 Dwellings
 WITH M69 Bridge WITHOUT Enderby Bypass

WITHOUT ENDERBY BYPASS

Leicester Lane, Enderby
 JNY 8838
 Full Development of Lubbesthorpe WITH
 M69 Bridge
Employment & Residential Trips
 PM Peak (17:00 - 18:00)
 PCU's

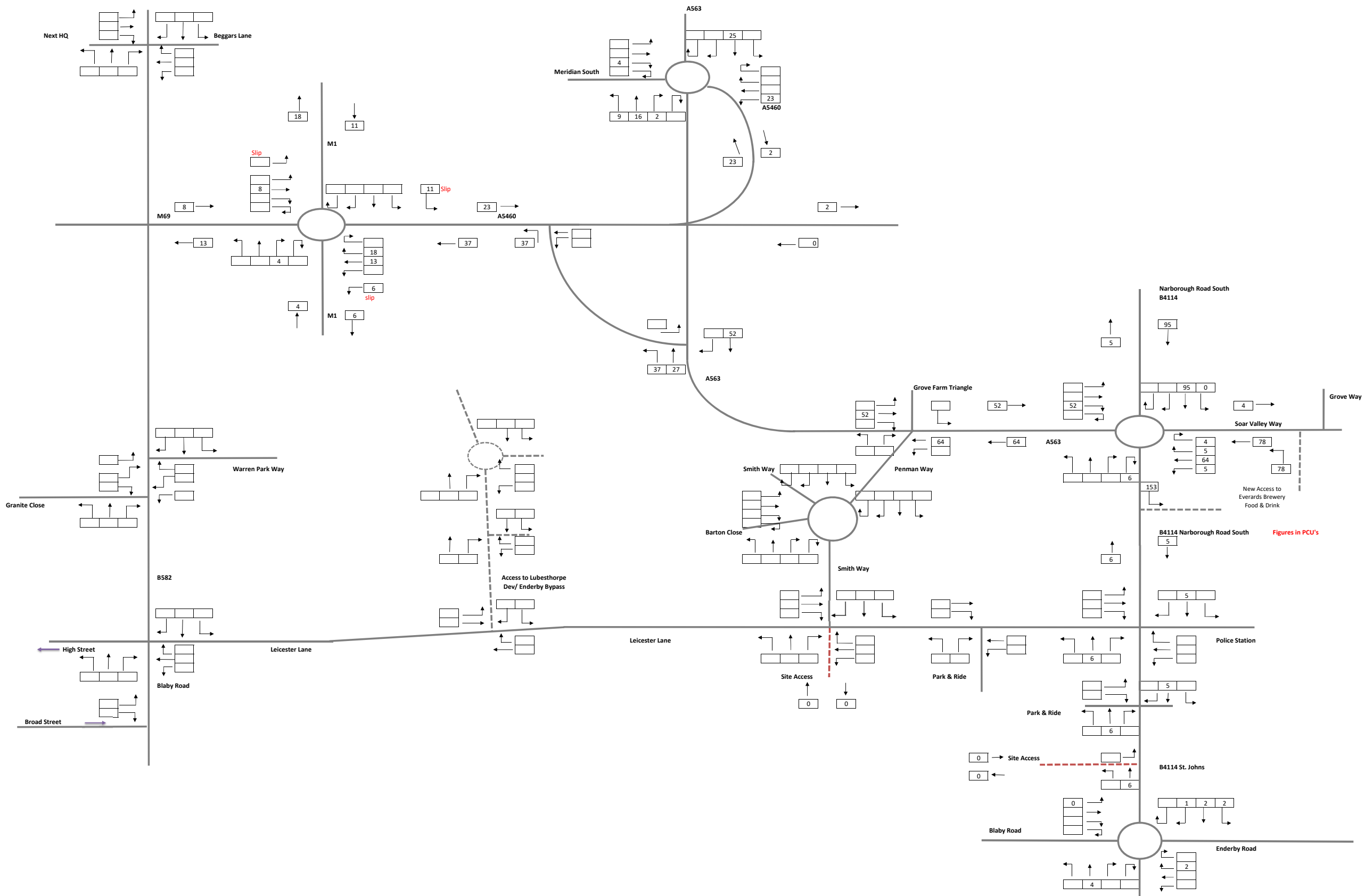

WITHOUT ENDERBY BYPASS

Leicester Lane, Enderby
 JNY 8838
 Committed Development - Everards Brewery
 Proposed Food & Drink Dev

AM Peak (08:00 - 09:00)
 PCU's

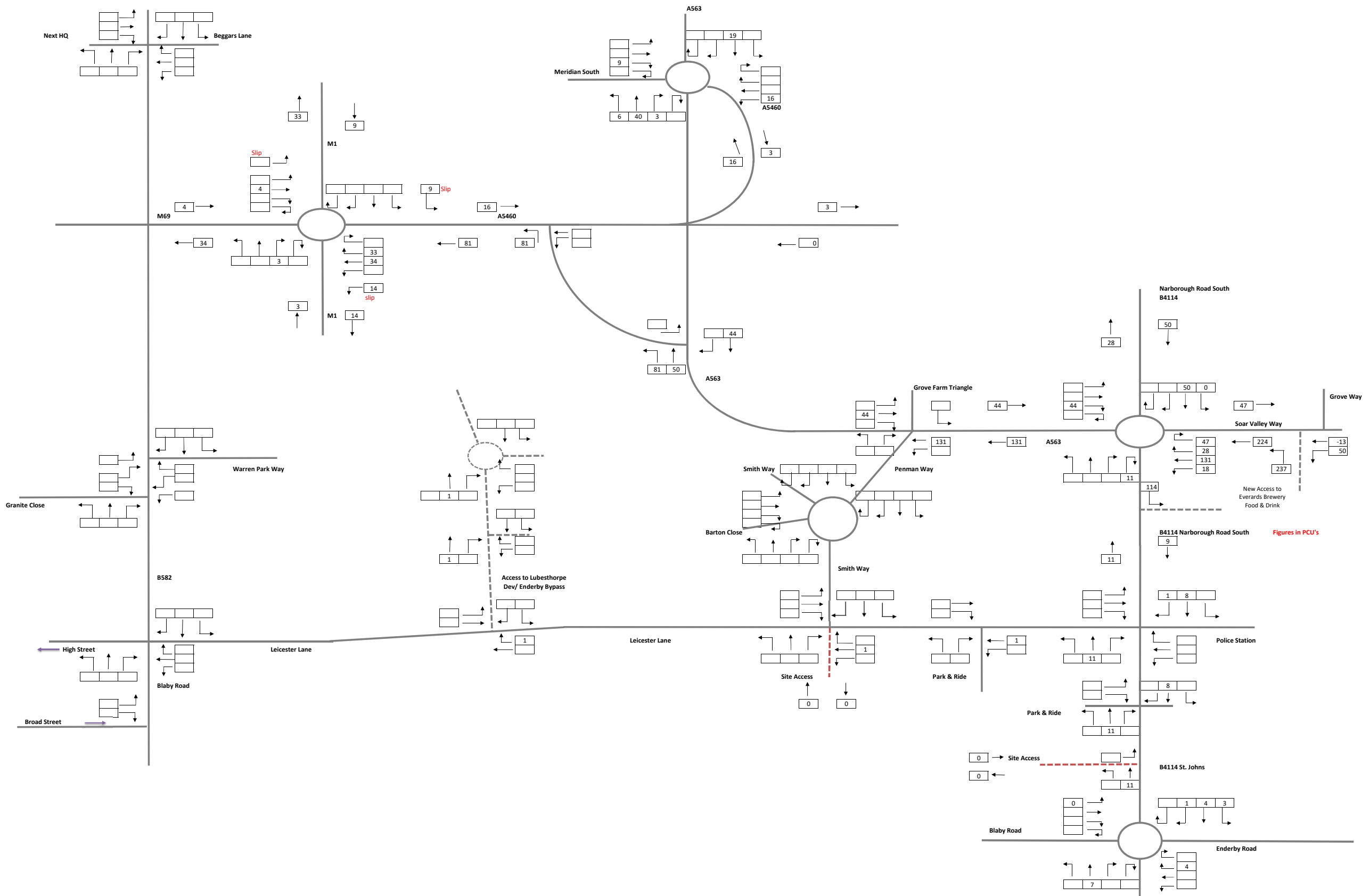

Figures in PCU's



WITHOUT ENDERBY BYPASS

Leicester Lane, Enderby
JNY 8838
Committed Development - Everards Brewery
Proposed Food & Drink Dev

PM Peak (17:00 - 18:00)
PCU's

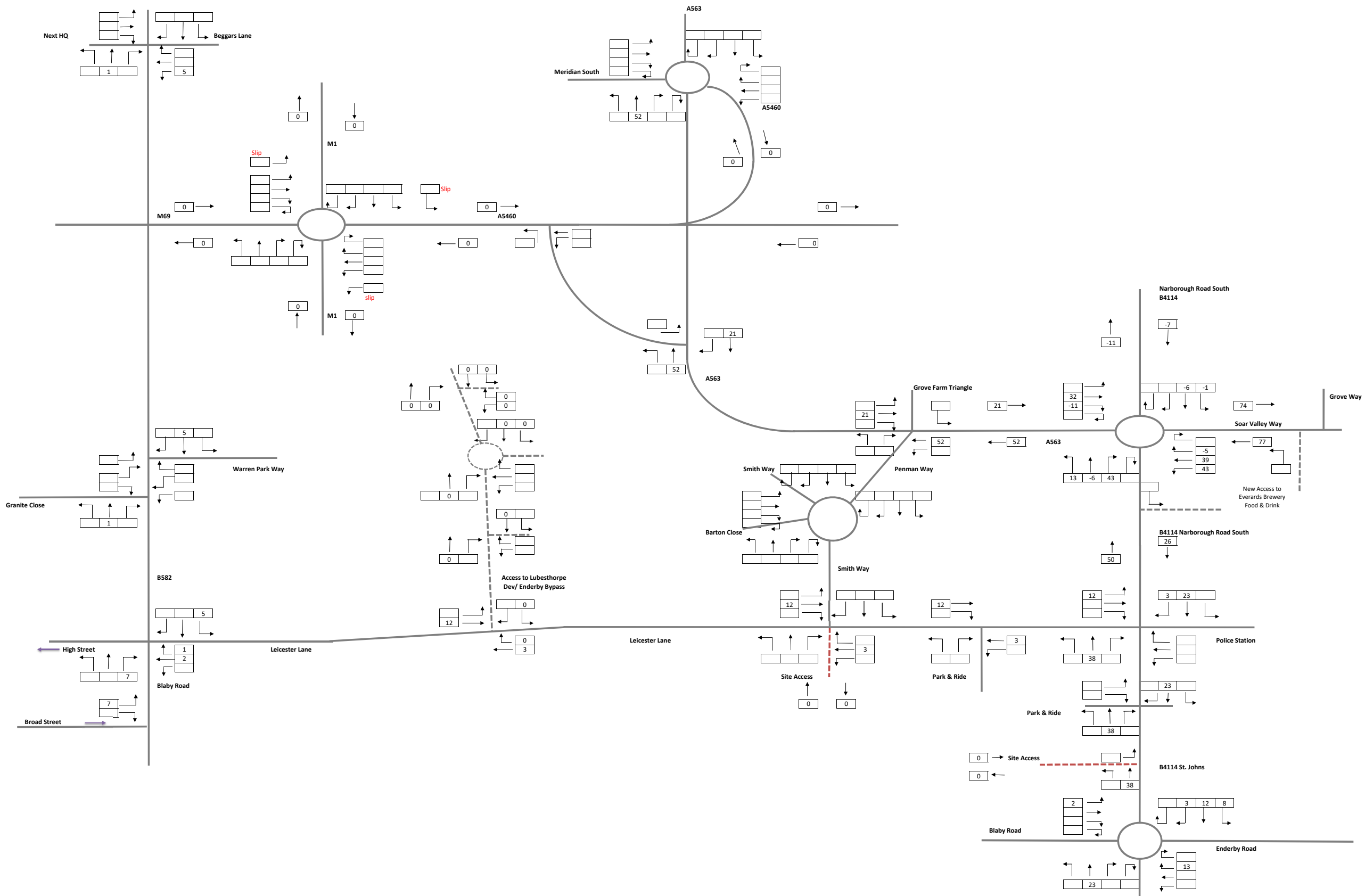

WITHOUT ENDERBY BYPASS

Leicester Lane, Enderby
 JNY 8838
NO M69 Bridge
 Committed Development - Castle Acres
 Proposed Retail Extn
 PM Peak (17:00 - 18:00)
 PCU's

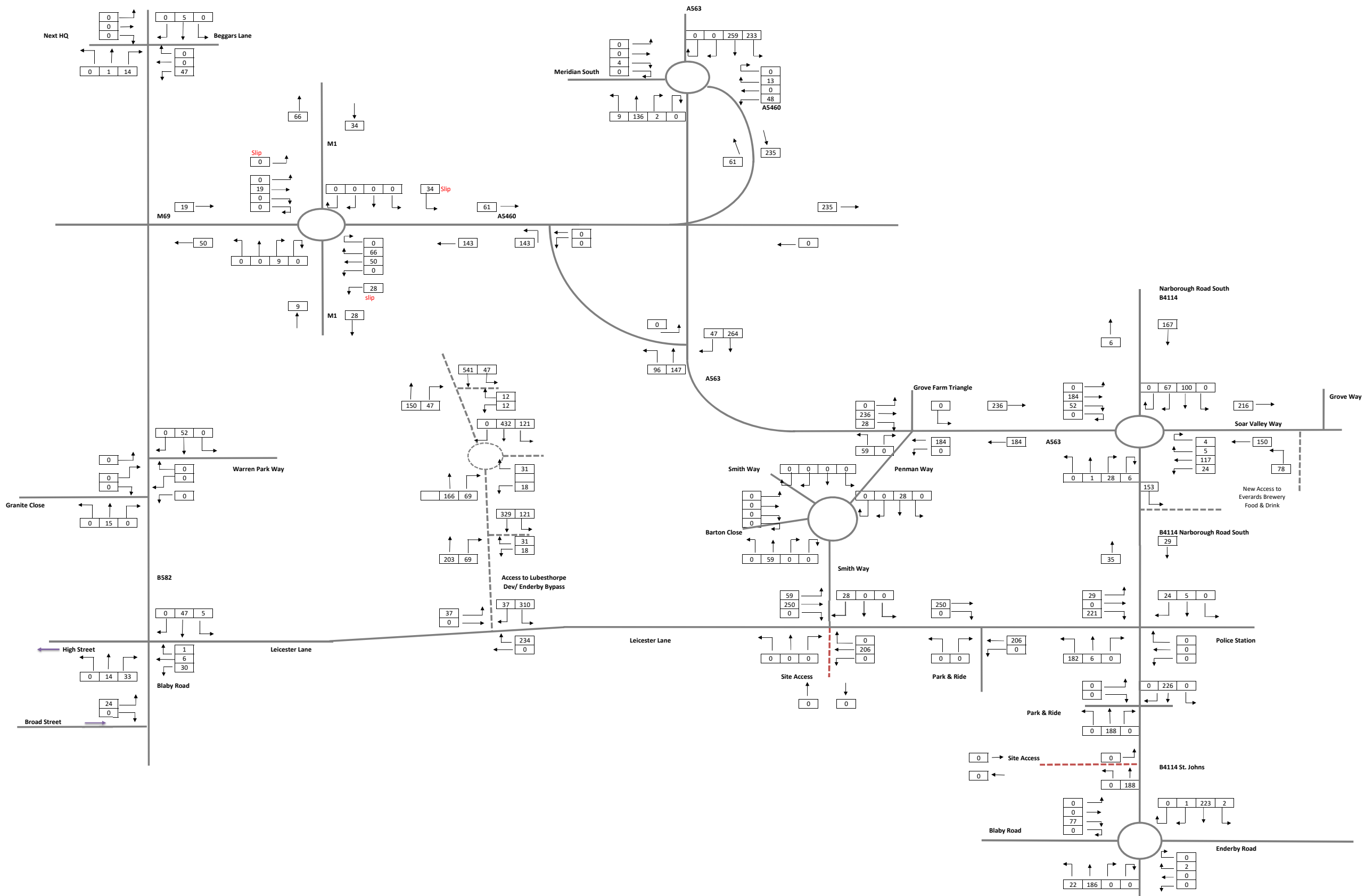

Note: Includes Lubbesthorpe Development Traffic, Everards Brewery & Castle Acres (Scn 2)

WITHOUT ENDERBY BYPASS

Leicester Lane, Enderby
 JNY 8838
 All Committed Development (Inc Full
 Lubbesthorpe & M69 Bridge)
 AM Peak (08:00 - 09:00)
 PCU's



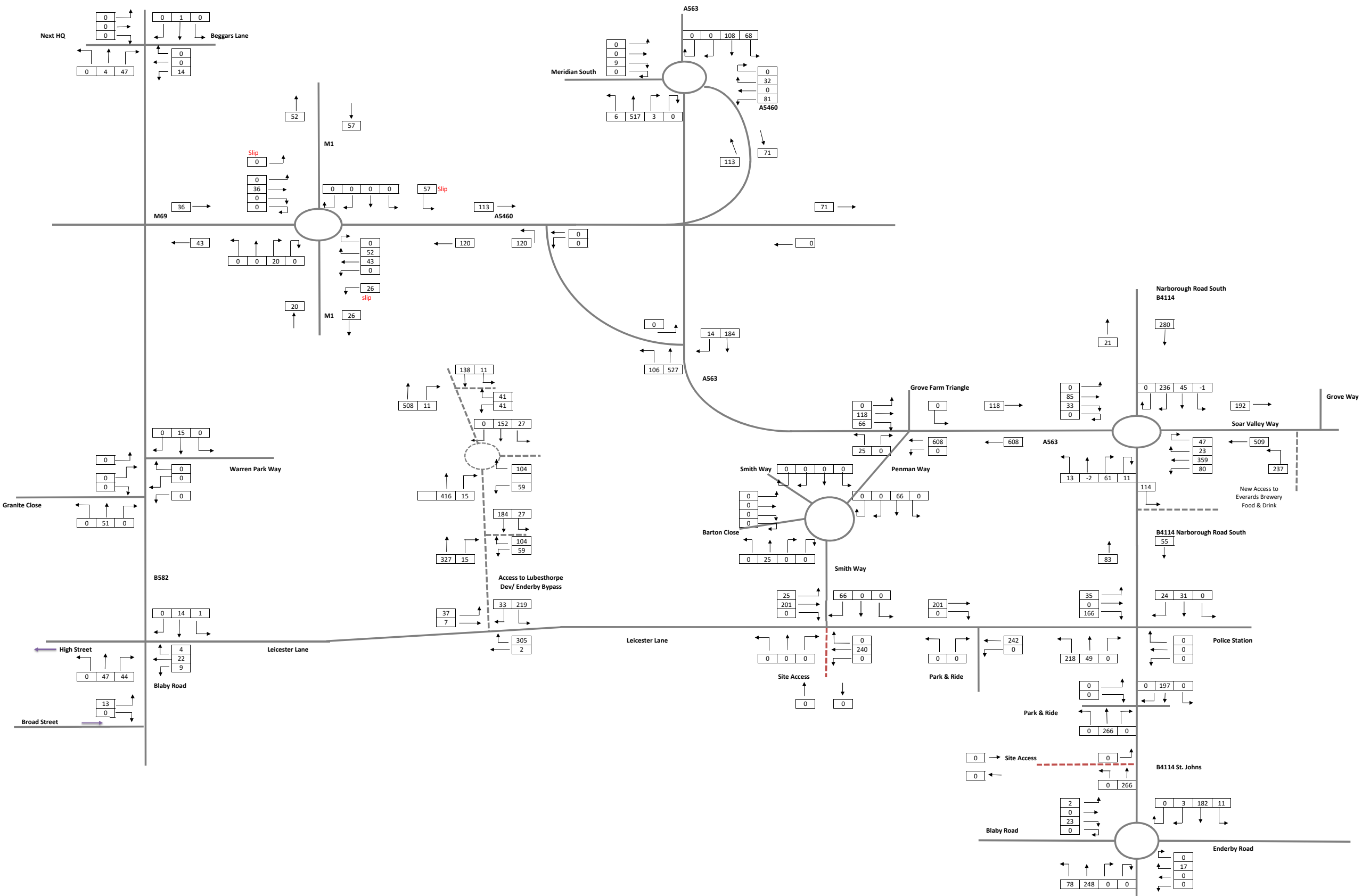

Note: Includes Lubbethorpe Development Traffic, Everards Brewery & Castle Acres (Scn 2)

WITHOUT ENDERBY BYPASS

Leicester Lane, Enderby
 JNY 8838
 All Committed Development (Inc Full
 Lubbethorpe & M69 Bridge)
 PM Peak (17:00 - 18:00)
 PCU's



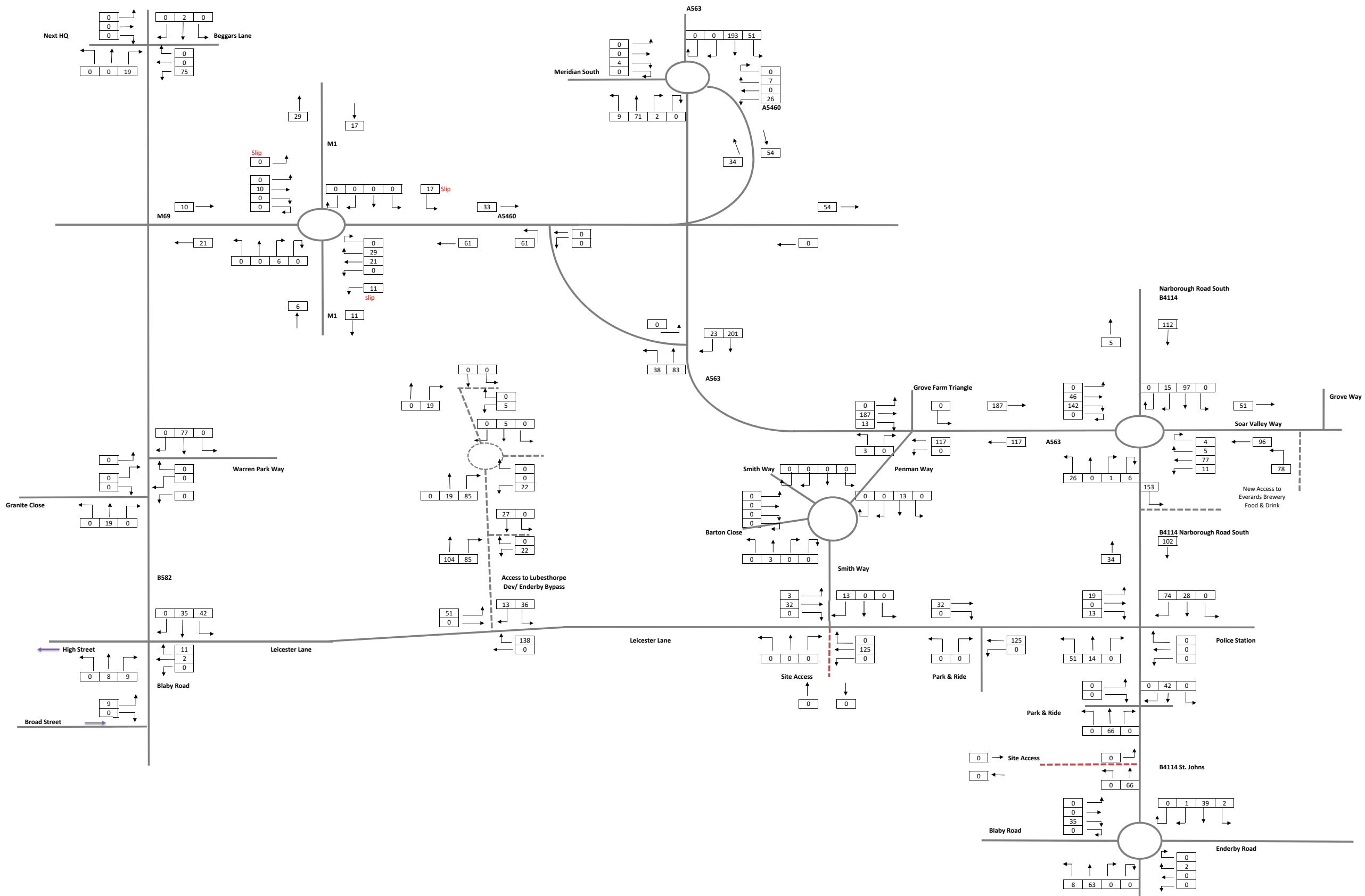

Note: Includes Lubbesthorpe Development Traffic, Everards Brewery & Castle Acres (Scn 2)

WITHOUT ENDERBY BYPASS

Leicester Lane, Enderby
 JNY 8838
 All Committed Development (Inc Part
 Lubbesthorpe NO M69 Bridge)
 AM Peak (08:00 - 09:00)
 PCU's



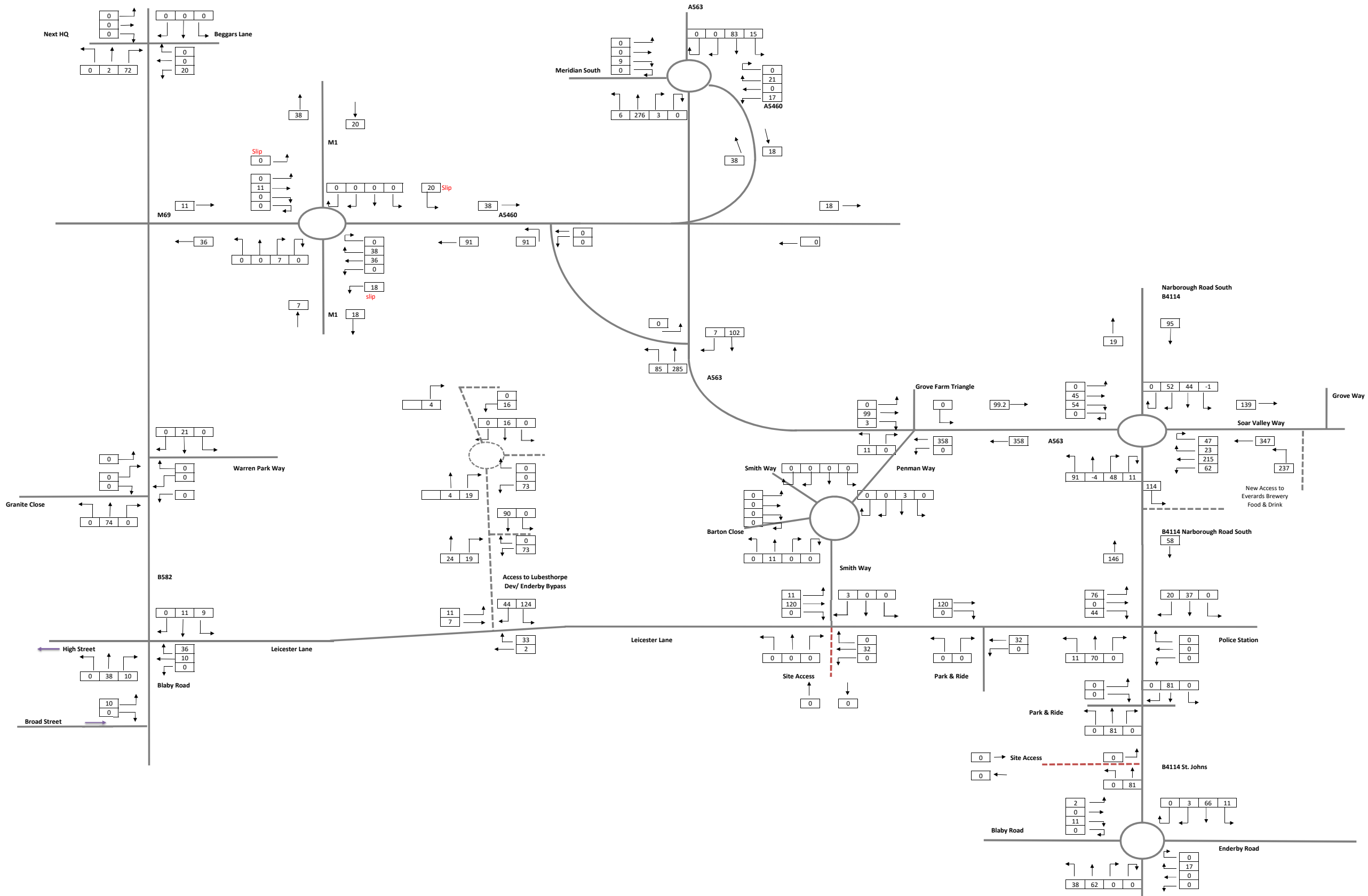

Note: Includes Lubbesthorpe Development Traffic, Everards Brewery & Castle Acres (Scn 2)

WITHOUT ENDERBY BYPASS

Leicester Lane, Enderby
 JNY 8838
 All Committed Development (Inc Part
 Lubbesthorpe NO M69 Bridge)
 PM Peak (17:00 - 18:00)
 PCU's



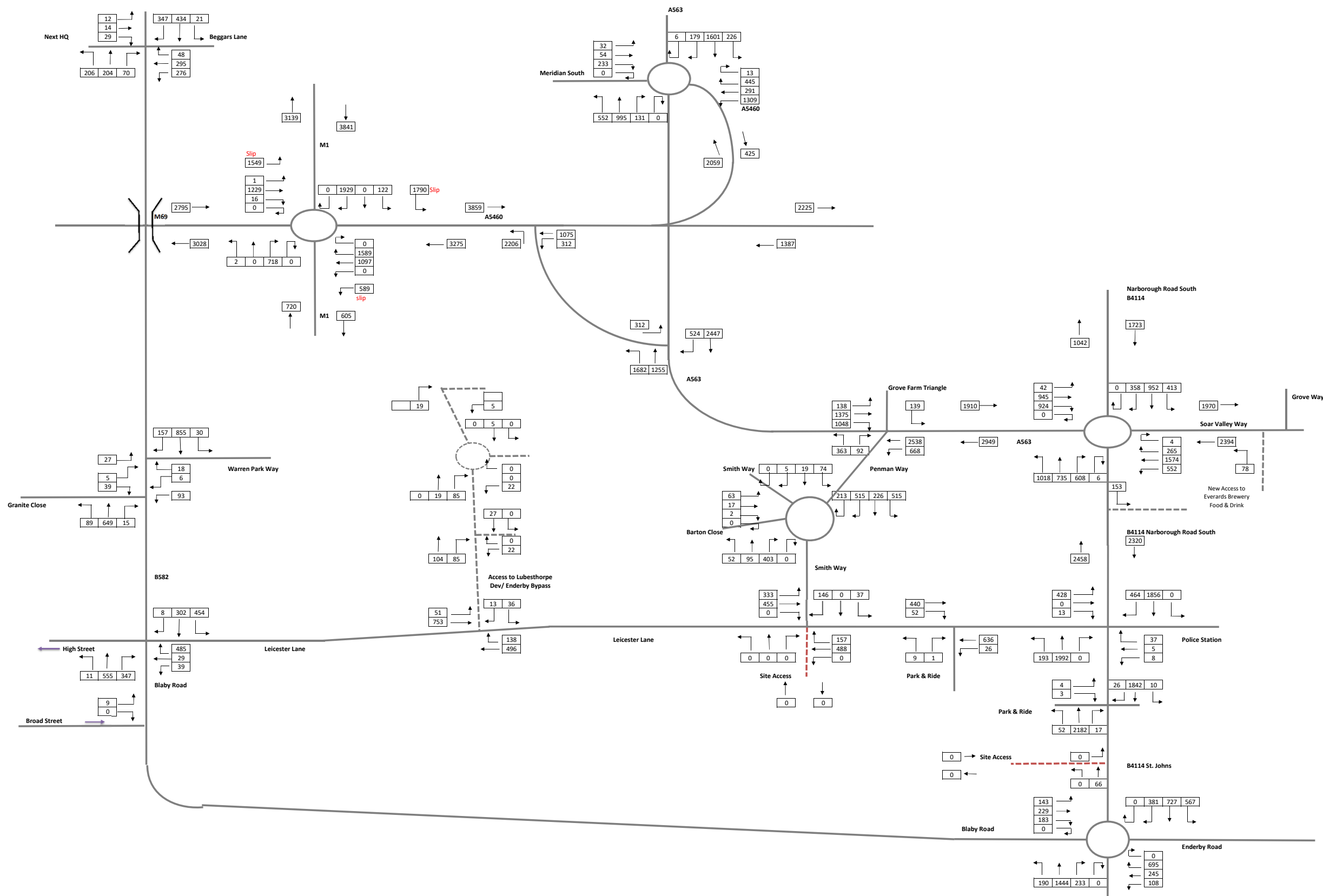

WITHOUT ENDERBY BYPASS

Leicester Lane, Enderby
 JNY 8838
 Base & Committed Traffic Flows (Part
 Lubbesthorpe)
 AM Peak (08:00 - 09:00)
 PCU's
 WITHOUT M69 Bridge

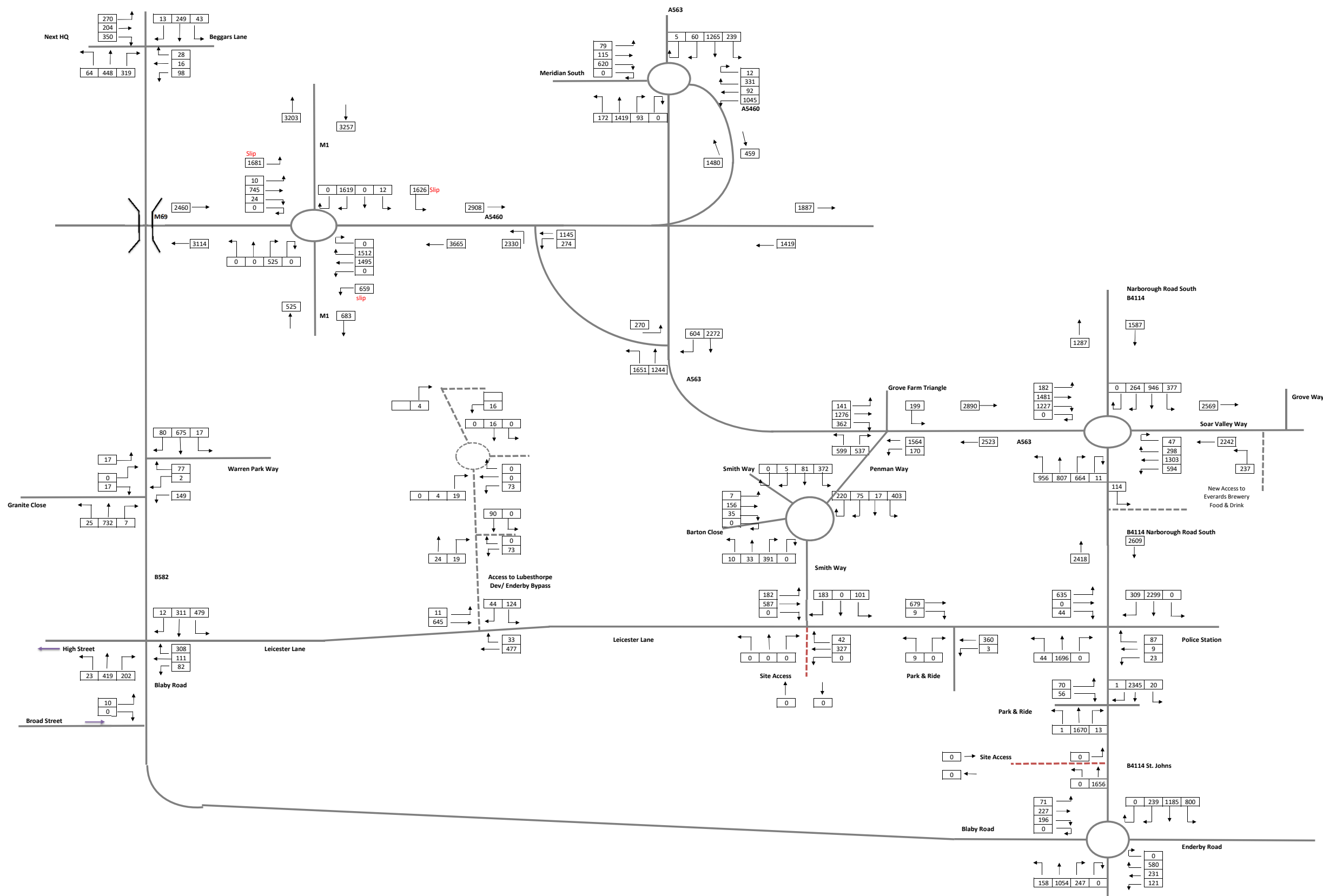

WITHOUT ENDERBY BYPASS

Leicester Lane, Enderby
 JNY 8838
 Base & Committed Traffic Flows (Part
 Lubbesthorpe)
 PM Peak (17:00 - 18:00)
 PCU's
 WITHOUT M69 Bridge

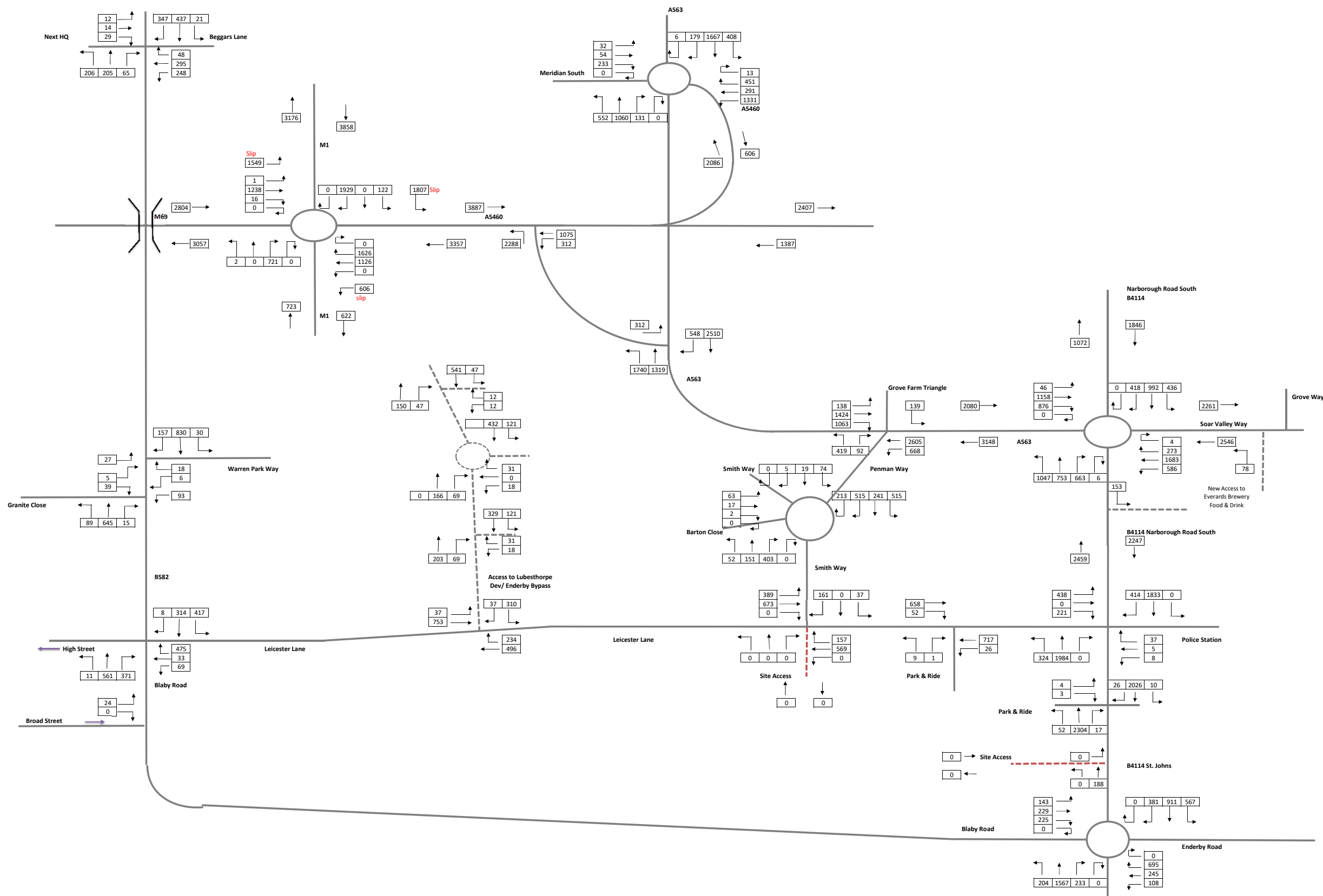

WITHOUT ENDERBY BYPASS

Leicester Lane, Enderby
 JNY 8838
Base & Committed Traffic Flows
 AM Peak (08:00 - 09:00)
 PCU's
 WITH M69 Bridge

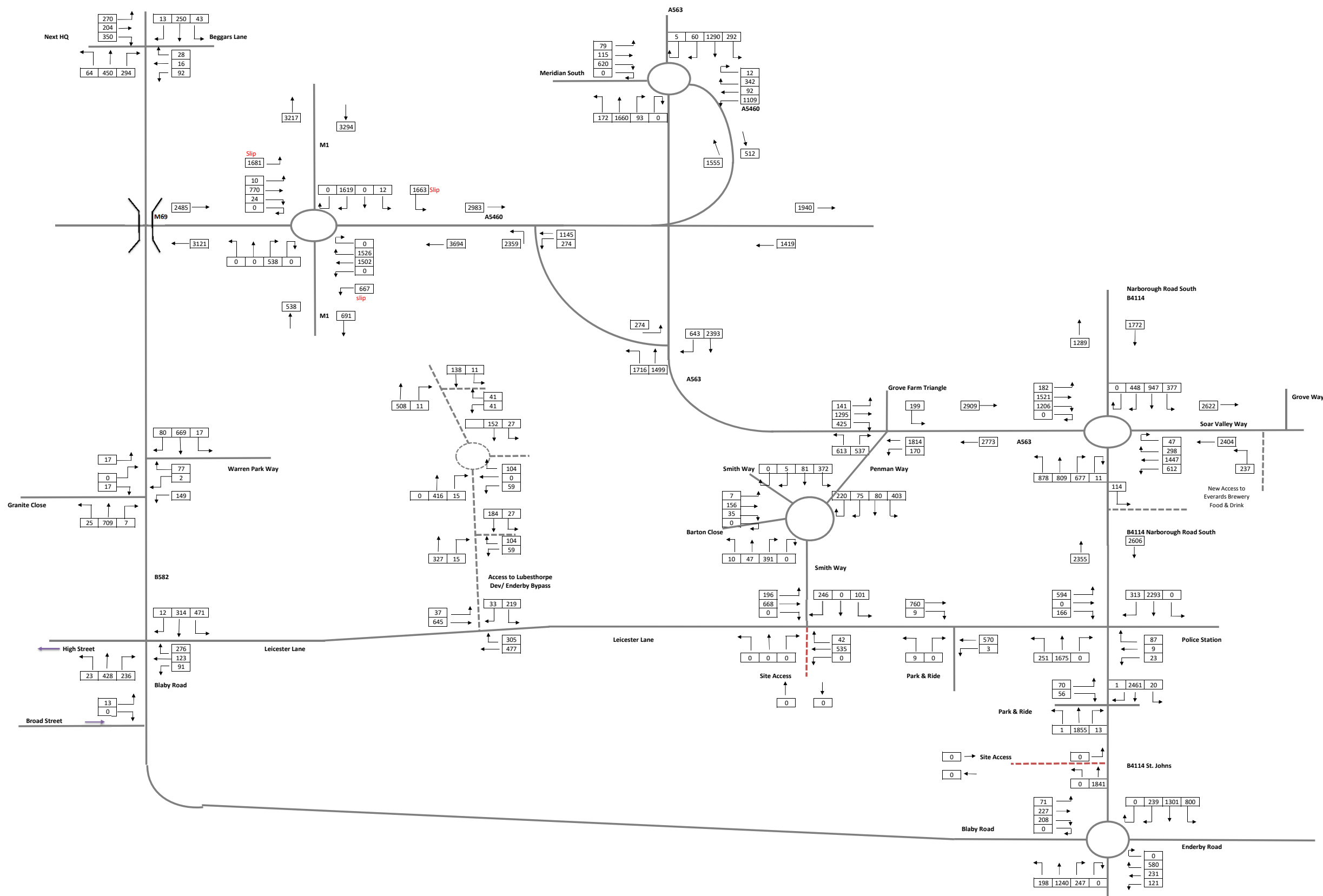

WITHOUT ENDERBY BYPASS

Leicester Lane, Enderby
 JNY 8838
Base & Committed Traffic Flows
 PM Peak (17:00 - 18:00)
 PCU's
 WITH M69 Bridge

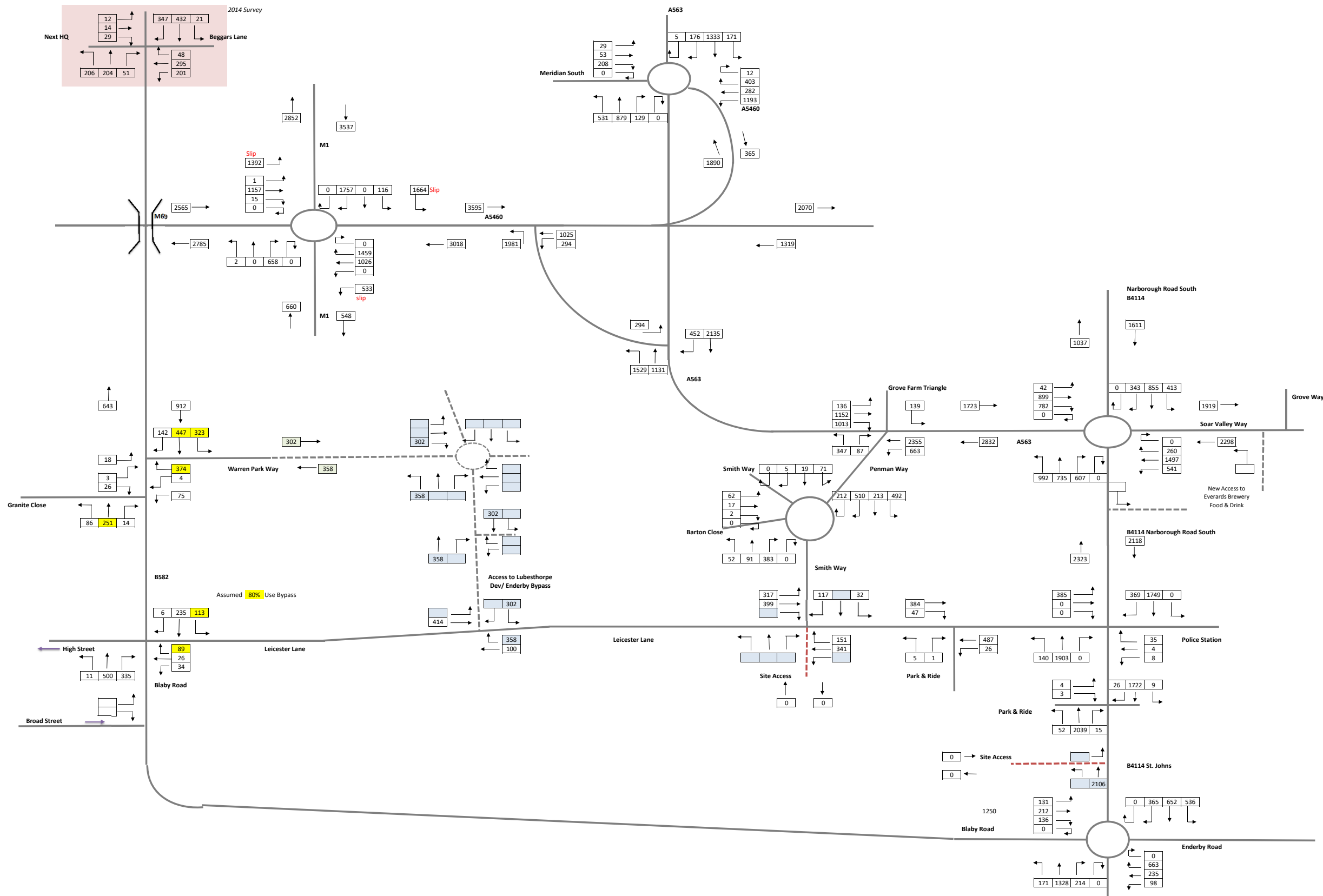

WITH ENDERBY BYPASS

Leicester Lane, Enderby
 JNY 8838
 2015 Base Traffic Flows
 distributed with Bypass
 AM Peak (08:00 - 09:00)
 All Vehicles

Re-

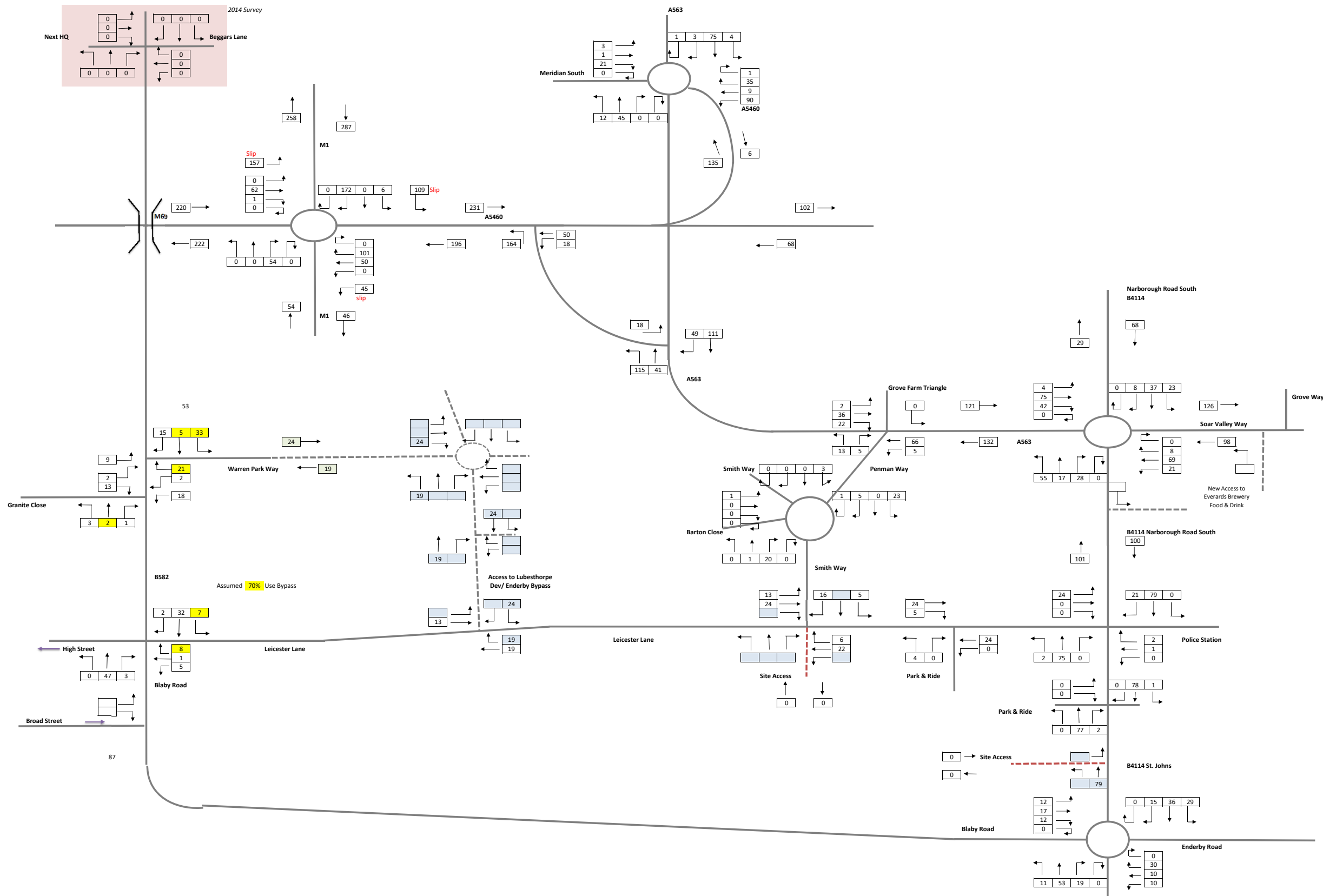

WITH ENDERBY BYPASS

Leicester Lane, Enderby
 JNY 8838
2015 Base Traffic Flows
 distributed with Bypass
 AM Peak (08:00 - 09:00)
 HGV's & Buses

Re-

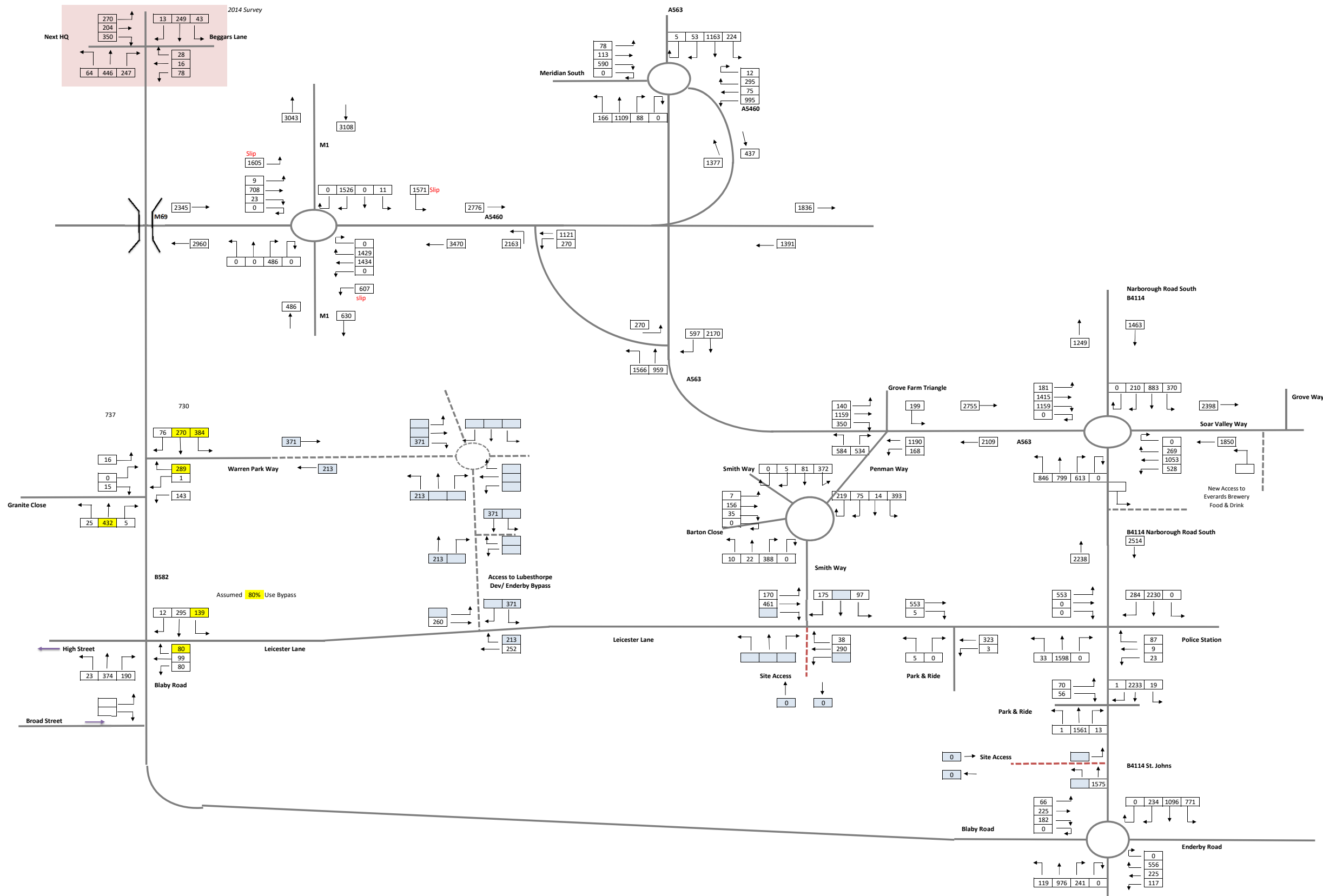

WITH ENDERBY BYPASS

Leicester Lane, Enderby
 JNY 8838
 2015 Base Traffic Flows
 distributed with Bypass
 PM Peak (17:00 - 16:00)
 All Vehicles

Re-

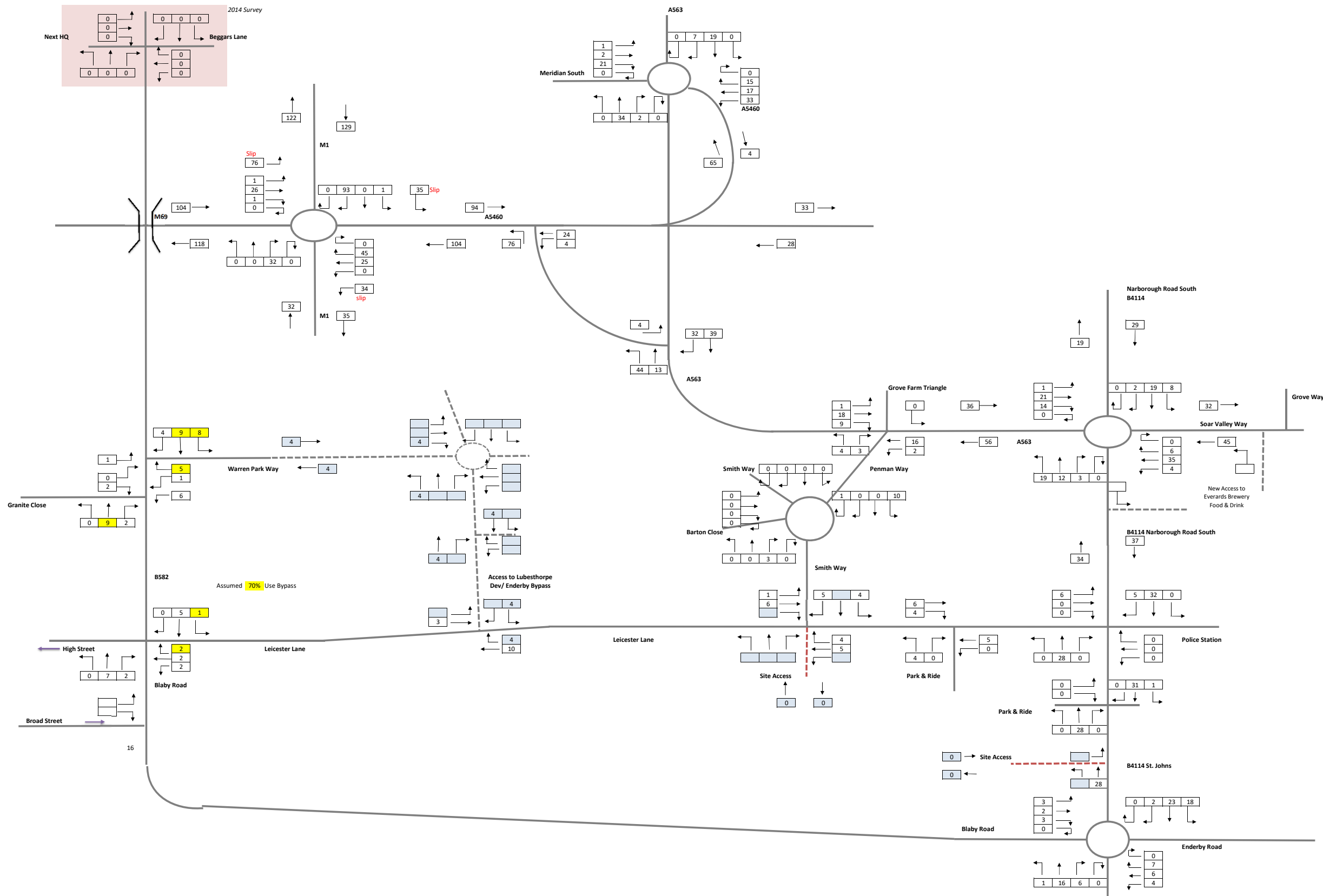

WITH ENDERBY BYPASS

Leicester Lane, Enderby
 JNY 8838
 2015 Base Traffic Flows
 distributed with Bypass
 PM Peak (17:00 - 16:00)
 HGV's & Buses

Re-

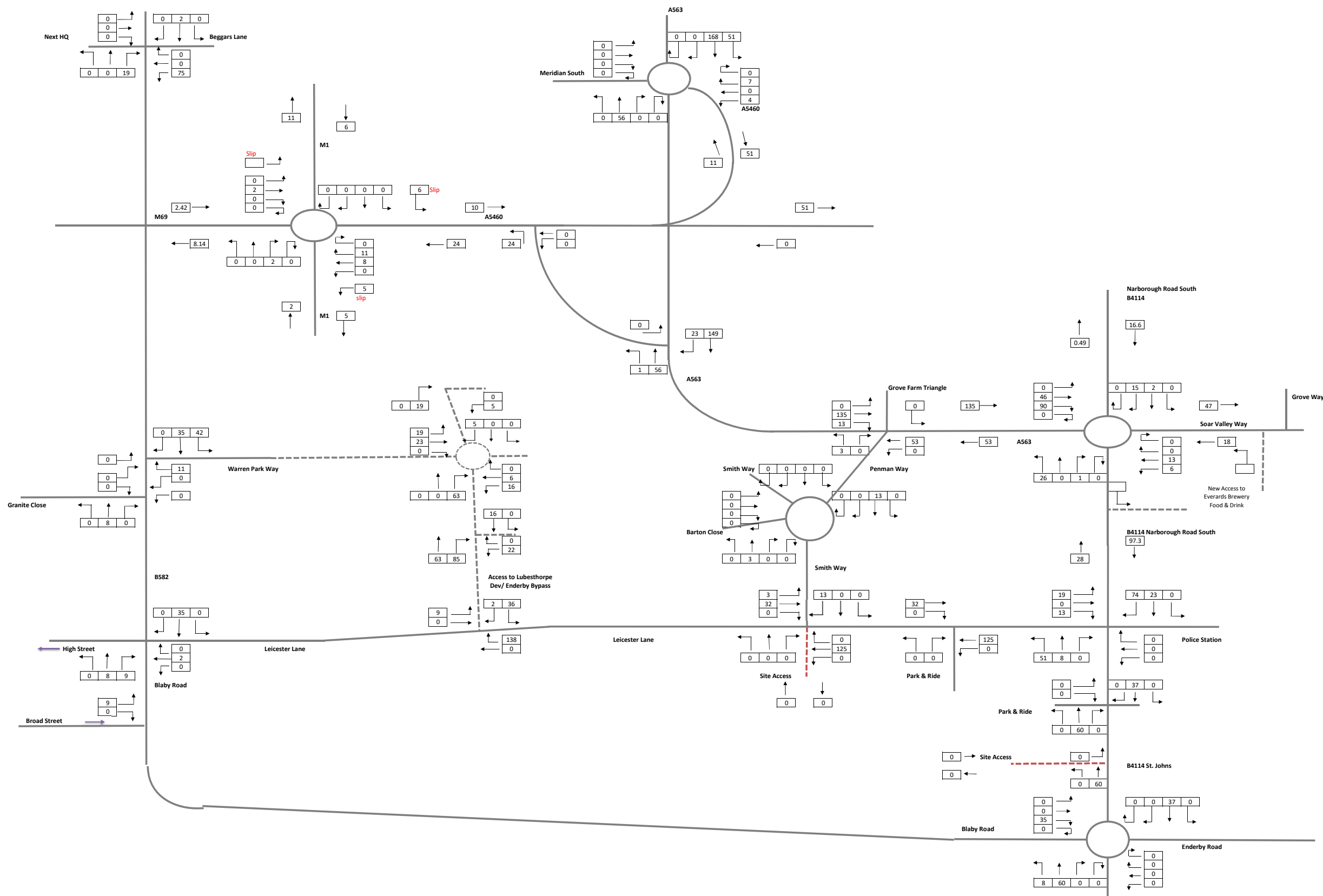

Note: Traffic Movements associated with the Lubbesthorpe Development have been based the traffic flows provided in the original Lubbesthorpe TA.

Lubbesthorpe Development
 40% Employment
 1000 dwellings
WITHOUT M69 Bridge WITH Enderby Bypass

WITH ENDERBY BYPASS

Leicester Lane, Enderby
 JNY 8838
 Part Development of Lubbesthorpe NO M69 Bridge
Employment & Residential Trips
 AM Peak (08:00 - 09:00)
 PCU's

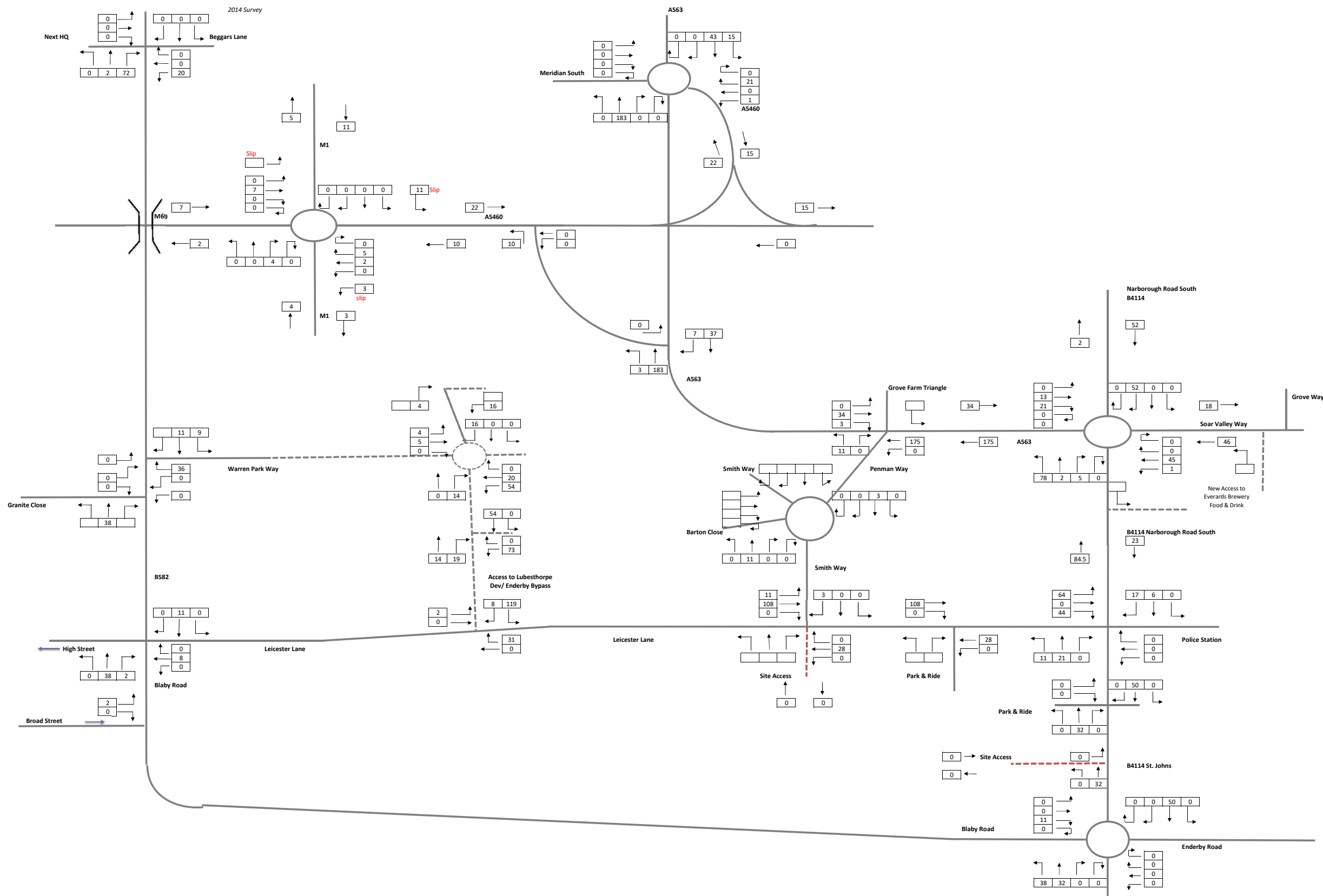

Note: Traffic Movements associated with the Lubbesthorpe Development have been based on the traffic flows provided in the original Lubbesthorpe TA.

Lubbesthorpe Development
 40% Employment
 1000 Dwellings
WITHOUT M69 Bridge WITH Enderby Bypass

WITH ENDERBY BYPASS

Leicester Lane, Enderby
 JNY 8838
 Part Development of Lubbesthorpe NO M69 Bridge
Employment & Residential Trips
 PM Peak (17:00 - 18:00)
 PCU's

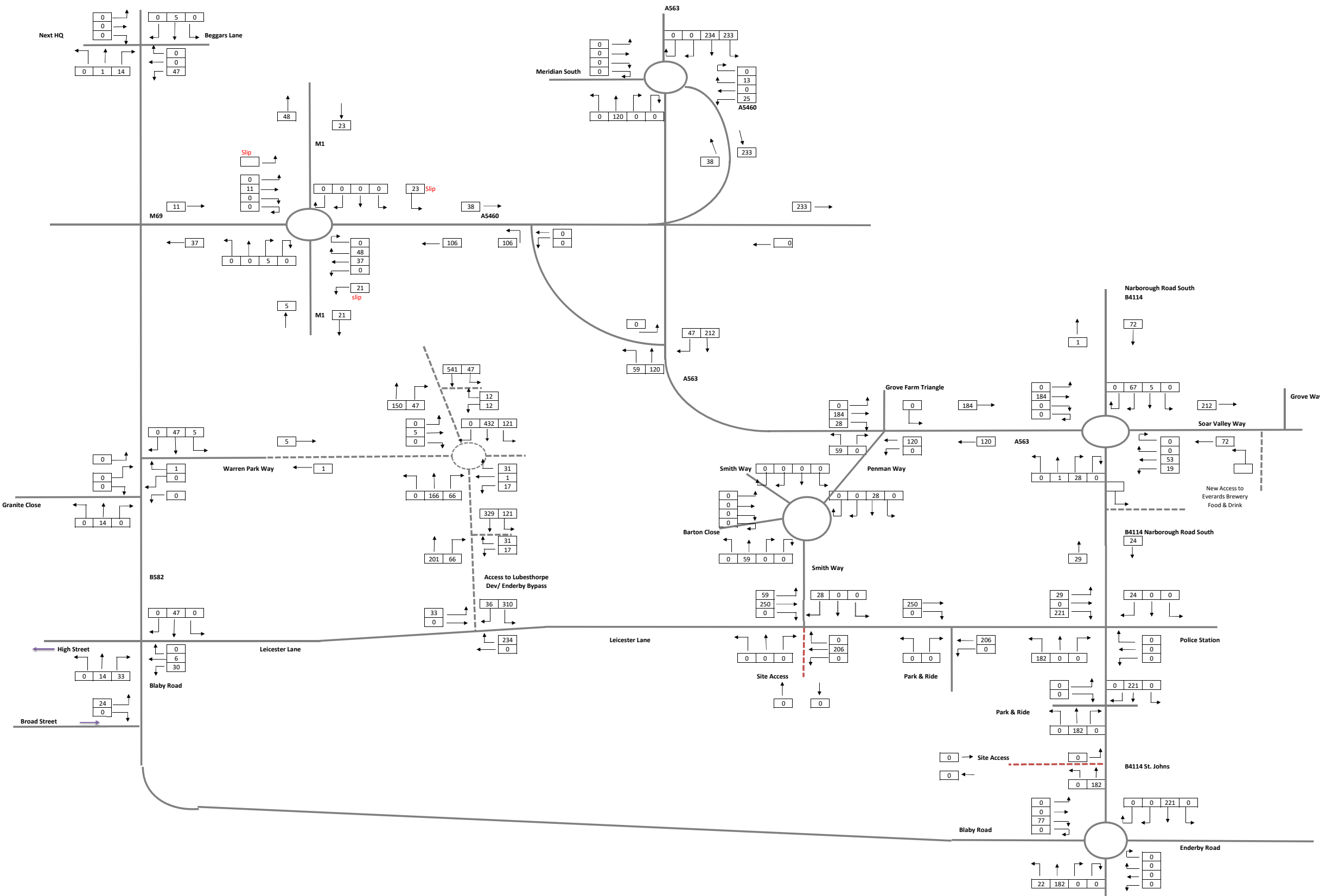

Note: Traffic Movements associated with the Lubbesthorpe Development have been based the traffic flows provided in the original Lubbesthorpe TA.

Lubbesthorpe Development
 100% Employment
 4500 Dwellings
 WITH M69 Bridge WITH Enderby Bypass

WITH ENDERBY BYPASS

Leicester Lane, Enderby
 JNY 8838
 Full Development of Lubbesthorpe WITH
 M69 Bridge
Employment & Residential Trips
 AM Peak (08:00 - 09:00)
 PCU's

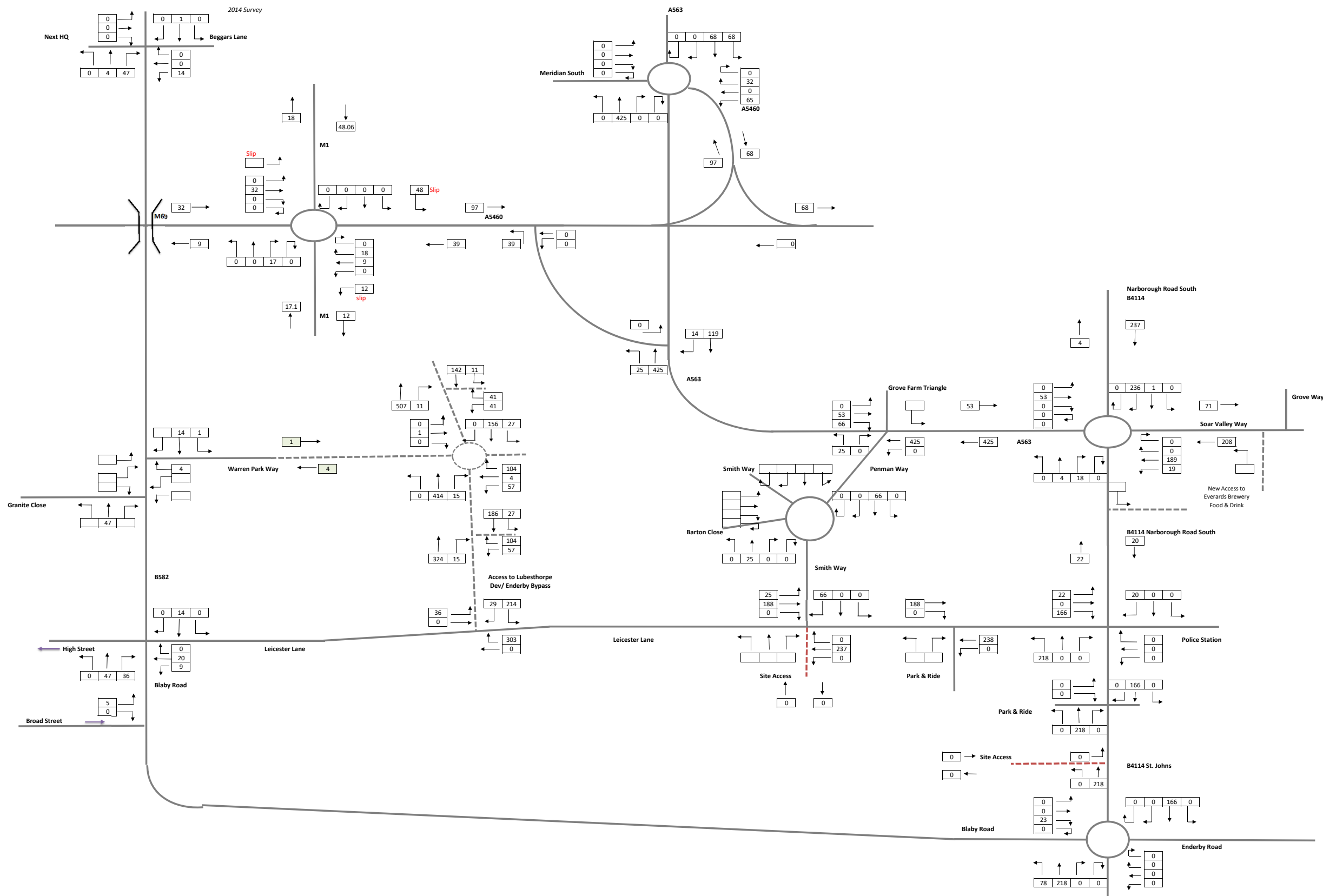

Note: Traffic Movements associated with the Lubbesthorpe Development have been based on the traffic flows provided in the original Lubbesthorpe TA.

Lubbesthorpe Development
 100% Employment
 4500 Dwellings
 WITH M69 Bridge WITH Enderby Bypass

WITH ENDERBY BYPASS

Leicester Lane, Enderby
 JNY 8838
 Full Development of Lubbesthorpe WITH
 M69 Bridge
Employment & Residential Trips
 PM Peak (17:00 - 18:00)
 PCU's

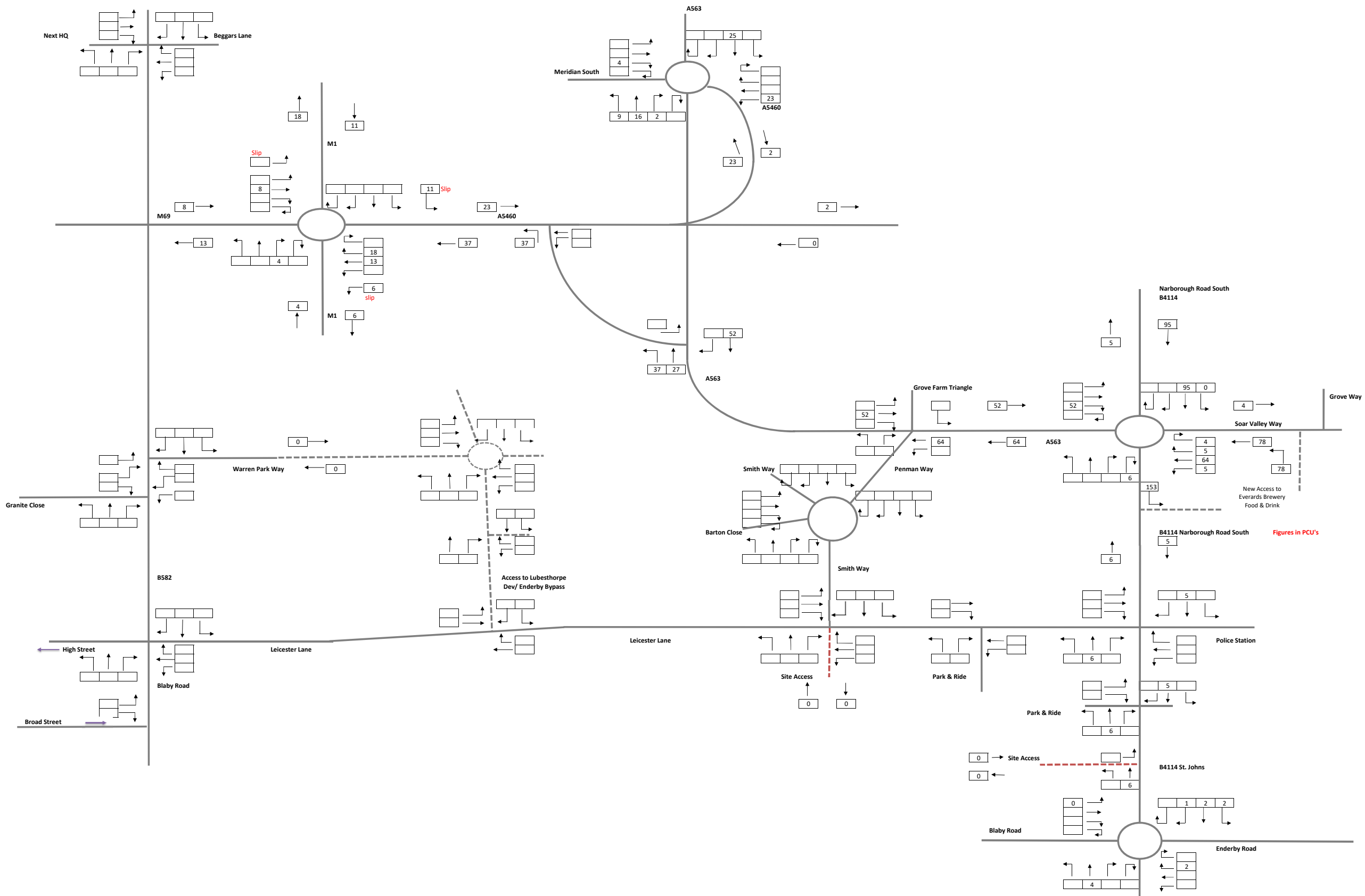

WITH ENDERBY BYPASS

Leicester Lane, Enderby
 JNY 8838
 Committed Development - Everards Brewery
 Proposed Food & Drink Dev

AM Peak (08:00 - 09:00)
 PCU's

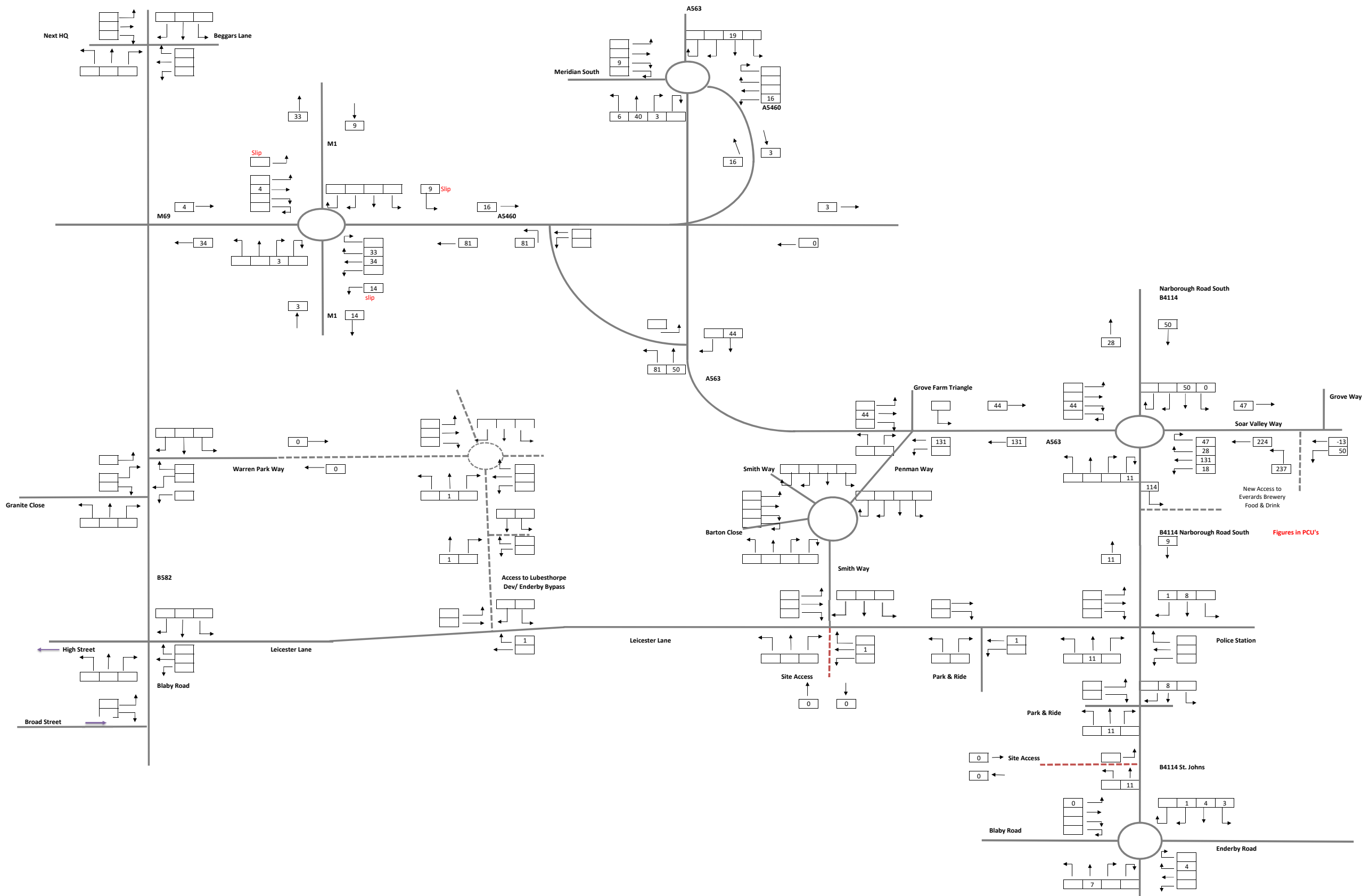

Figures in PCU's



WITH ENDERBY BYPASS

Leicester Lane, Enderby
 JNY 8838
 Committed Development - Everards Brewery
 Proposed Food & Drink Dev

PM Peak (17:00 - 18:00)
 PCU's

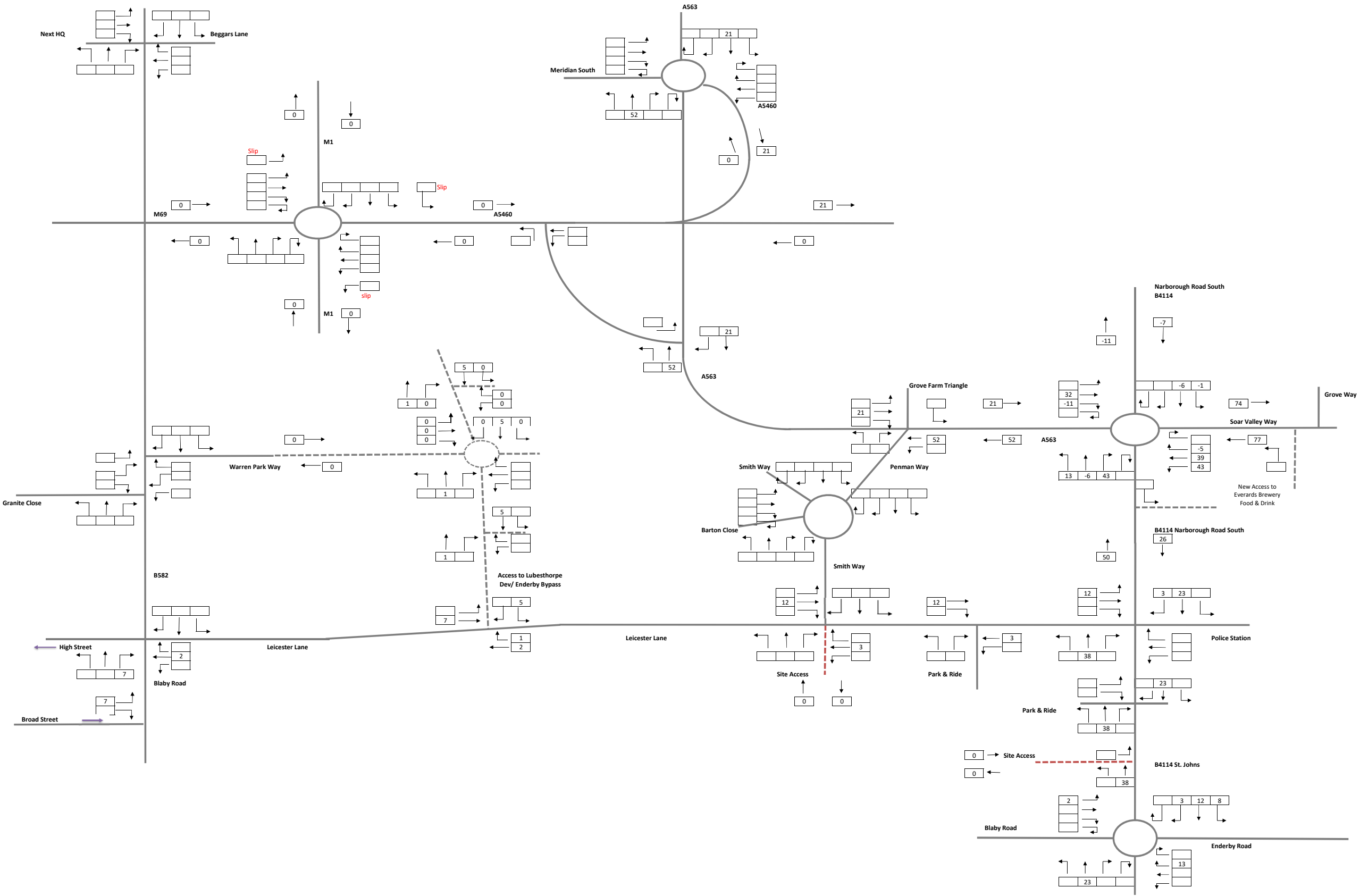

WITH ENDERBY BYPASS

Leicester Lane, Enderby
 JNY 8838
 Committed Development - Castle Acres
 Proposed Retail Extn
 PM Peak (17:00 - 18:00)
 PCU's

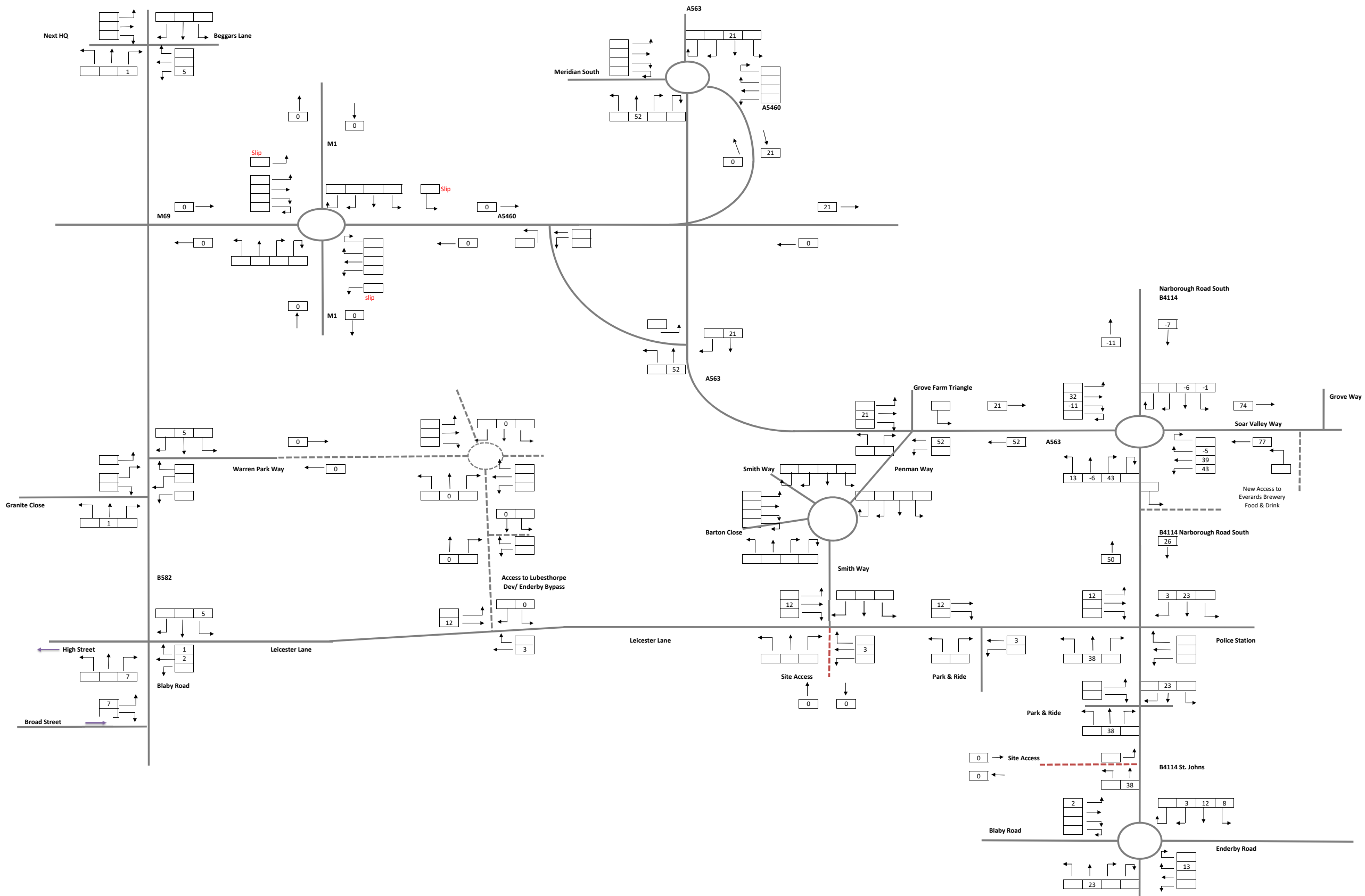

WITH ENDERBY BYPASS

Leicester Lane, Enderby
 JNY 8838
NO M69 Bridge
 Committed Development - Castle Acres
 Proposed Retail Extn
 PM Peak (17:00 - 18:00)
 PCU's

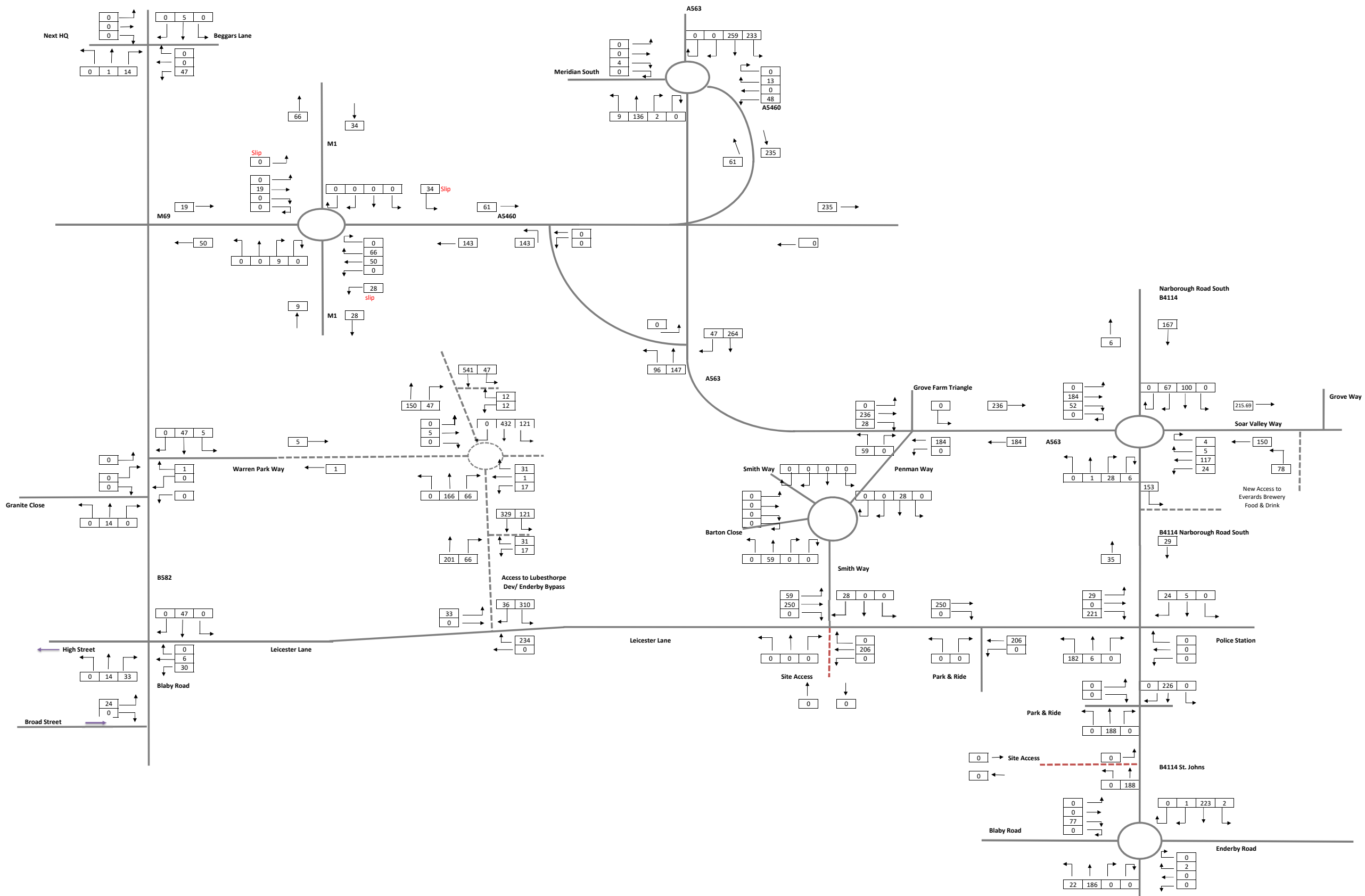

Note: Includes Lubbesthorpe Development Traffic, Everards Brewery & Castle Acres (Scn 2)

WITH ENDERBY BYPASS

Leicester Lane, Enderby
 JNY 8838
 All Committed Development (Inc Full
 Lubbesthorpe & M69 Bridge)
 AM Peak (08:00 - 09:00)
 PCU's



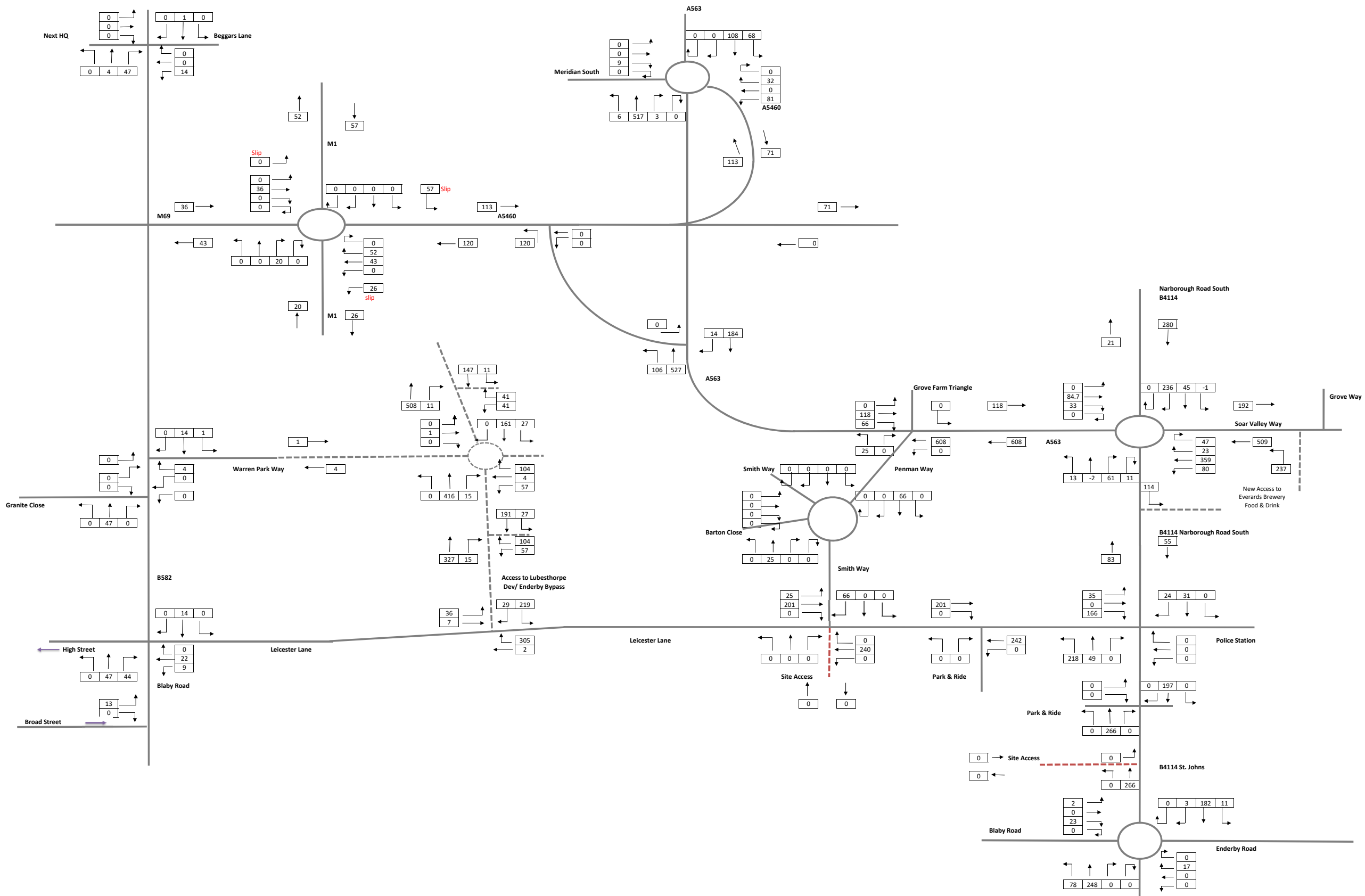

Note: Includes Lubbesthorpe Development Traffic, Everards Brewery & Castle Acres (Scn 2)

WITH ENDERBY BYPASS

Leicester Lane, Enderby
JNY 8838
All Committed Development (Inc Full
Lubbesthorpe & M69 Bridge)
PM Peak (17:00 - 18:00)
PCU's



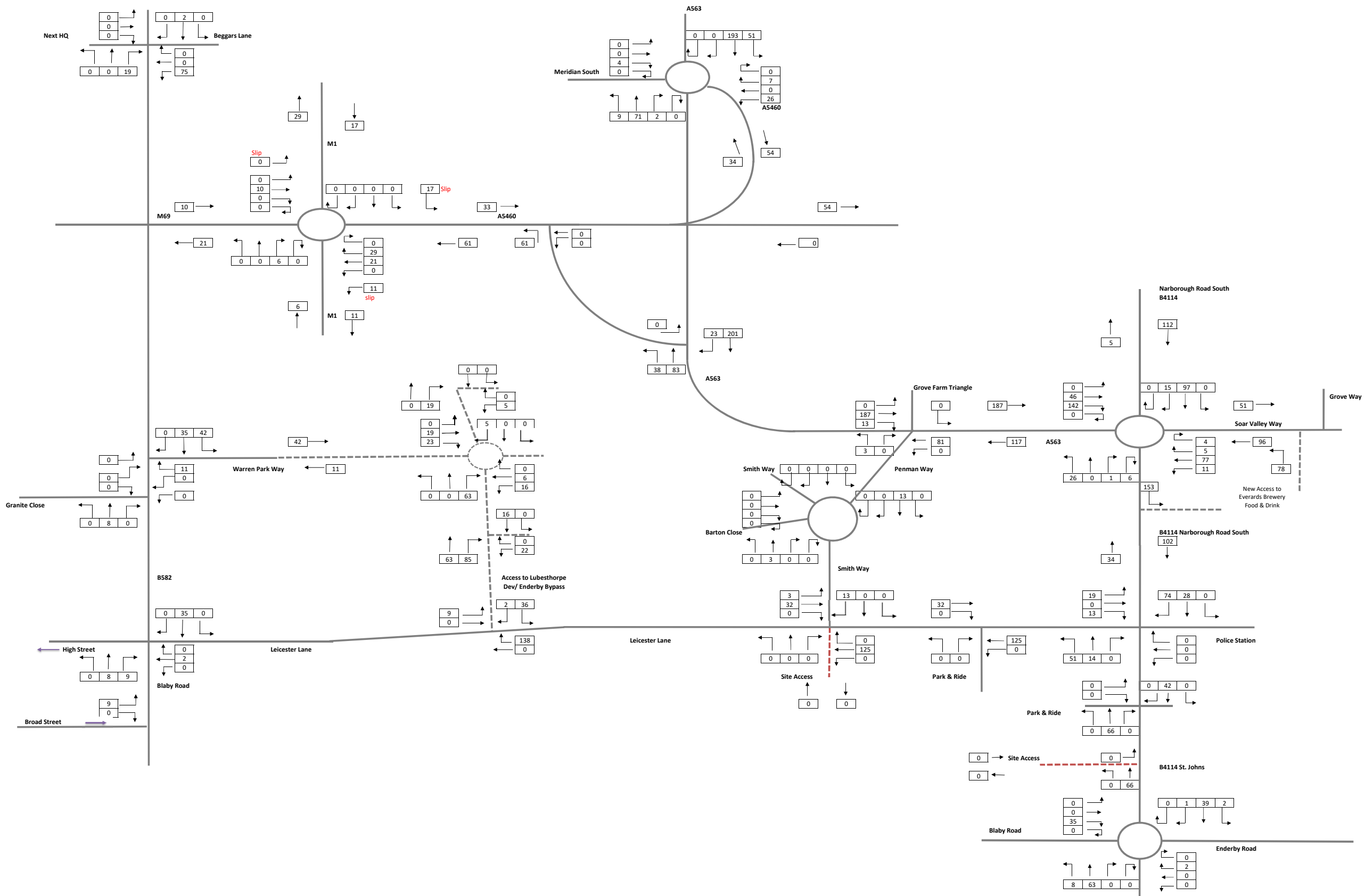

Note: Includes Lubbesthorpe Development Traffic, Everards Brewery & Castle Acres (Scn 2)

WITH ENDERBY BYPASS

Leicester Lane, Enderby
 JNY 8838
 All Committed Development (Inc Part
 Lubbesthorpe NO M69 Bridge)
 AM Peak (08:00 - 09:00)
 PCU's



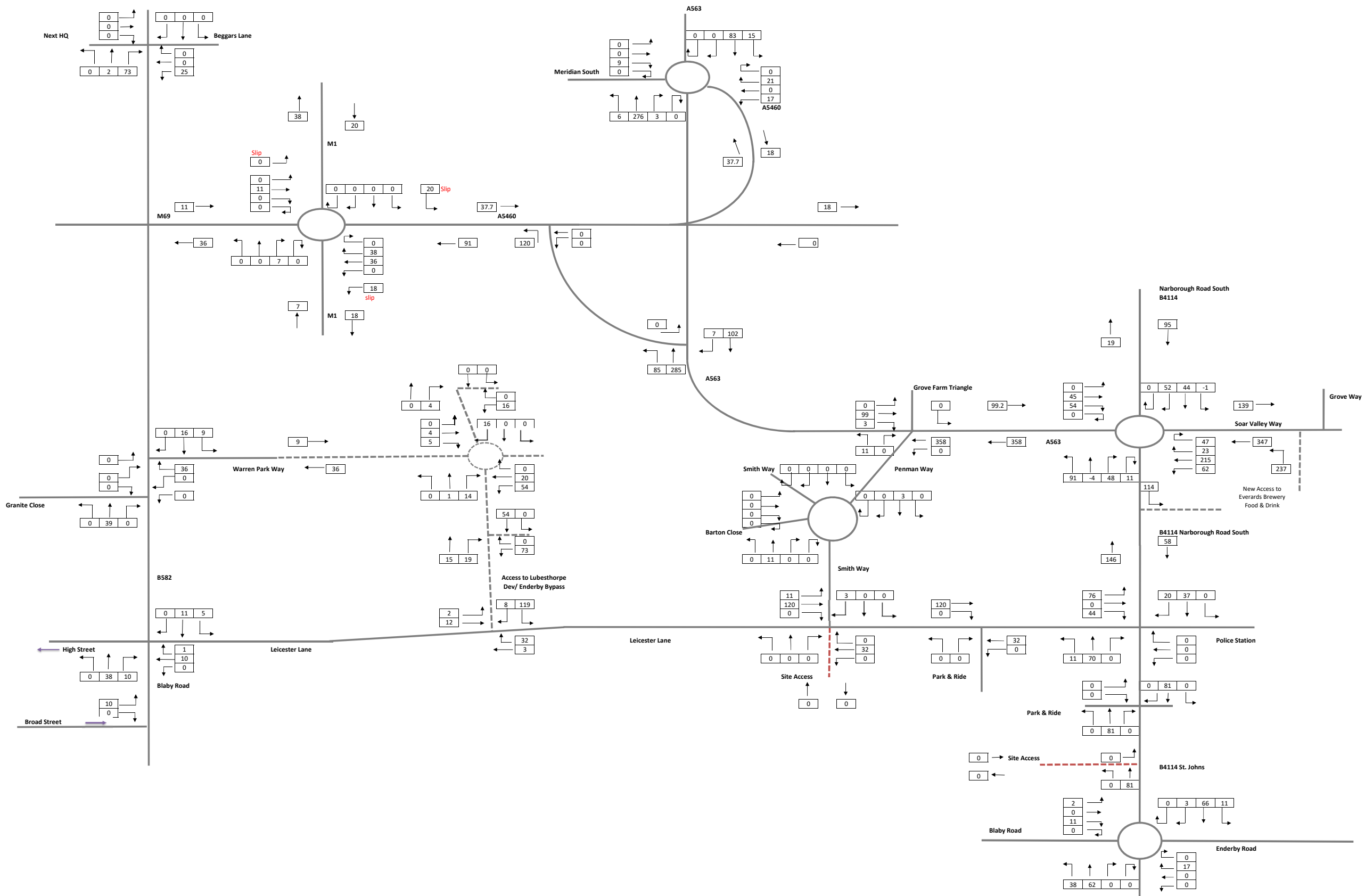

Note: Includes Lubbesthorpe Development Traffic, Everards Brewery & Castle Acres (Scn 2)

WITH ENDERBY BYPASS

Leicester Lane, Enderby
JNY 8838
All Committed Development (Inc Part
Lubbesthorpe NO M69 Bridge)
PM Peak (17:00 - 18:00)
PCU's



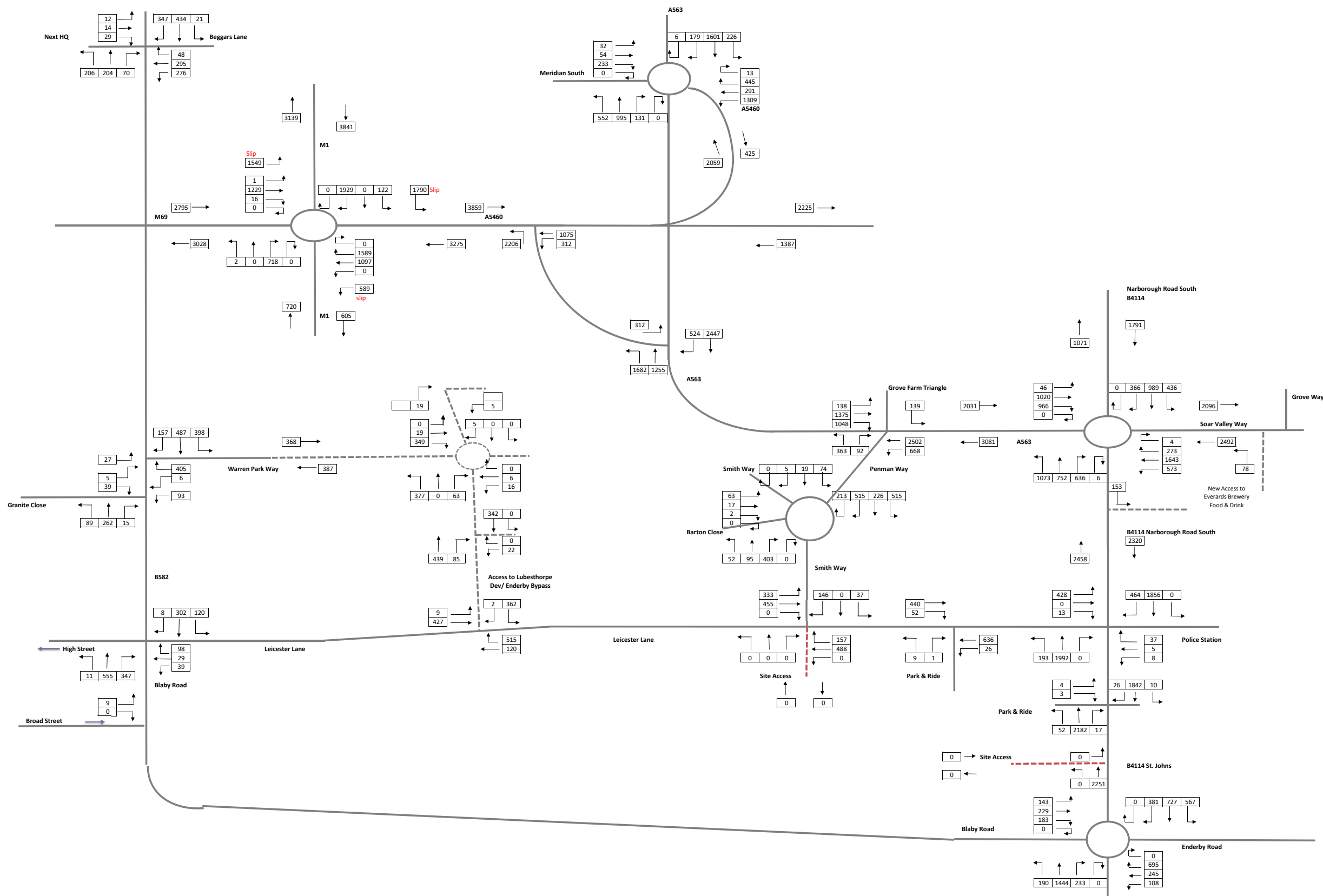

WITH ENDERBY BYPASS

Leicester Lane, Enderby
 JNY 8838
 Base & Committed Traffic Flows (Part
 Lubbesthorpe)
 AM Peak (08:00 - 09:00)
 PCU's
 WITHOUT M69 Bridge

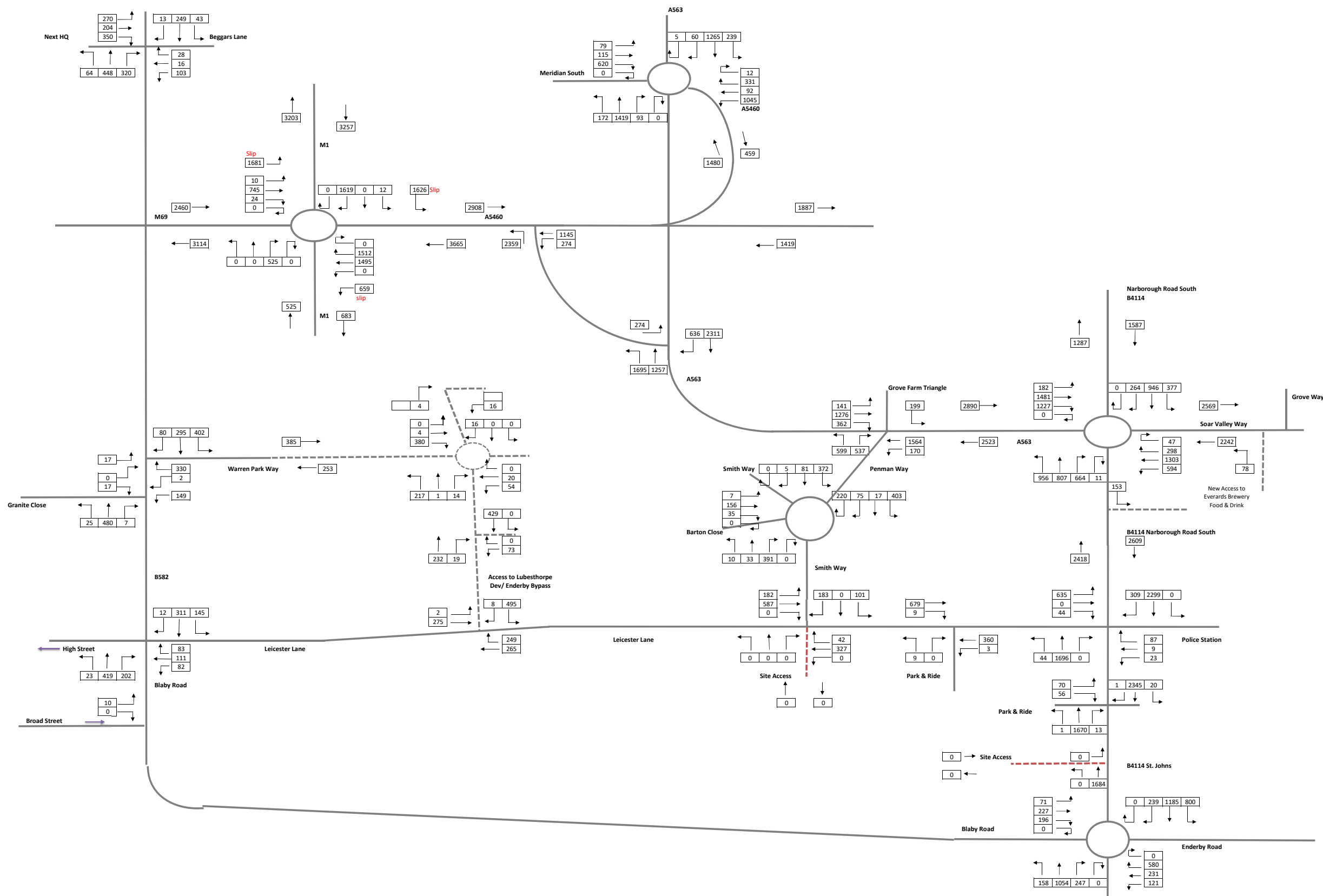

WITH ENDERBY BYPASS

Leicester Lane, Enderby
 JNY 8838
 Base & Committed Traffic Flows (Part
 Lubbesthorpe)
 PM Peak (17:00 - 18:00)
 PCU's
 WITHOUT M69 Bridge

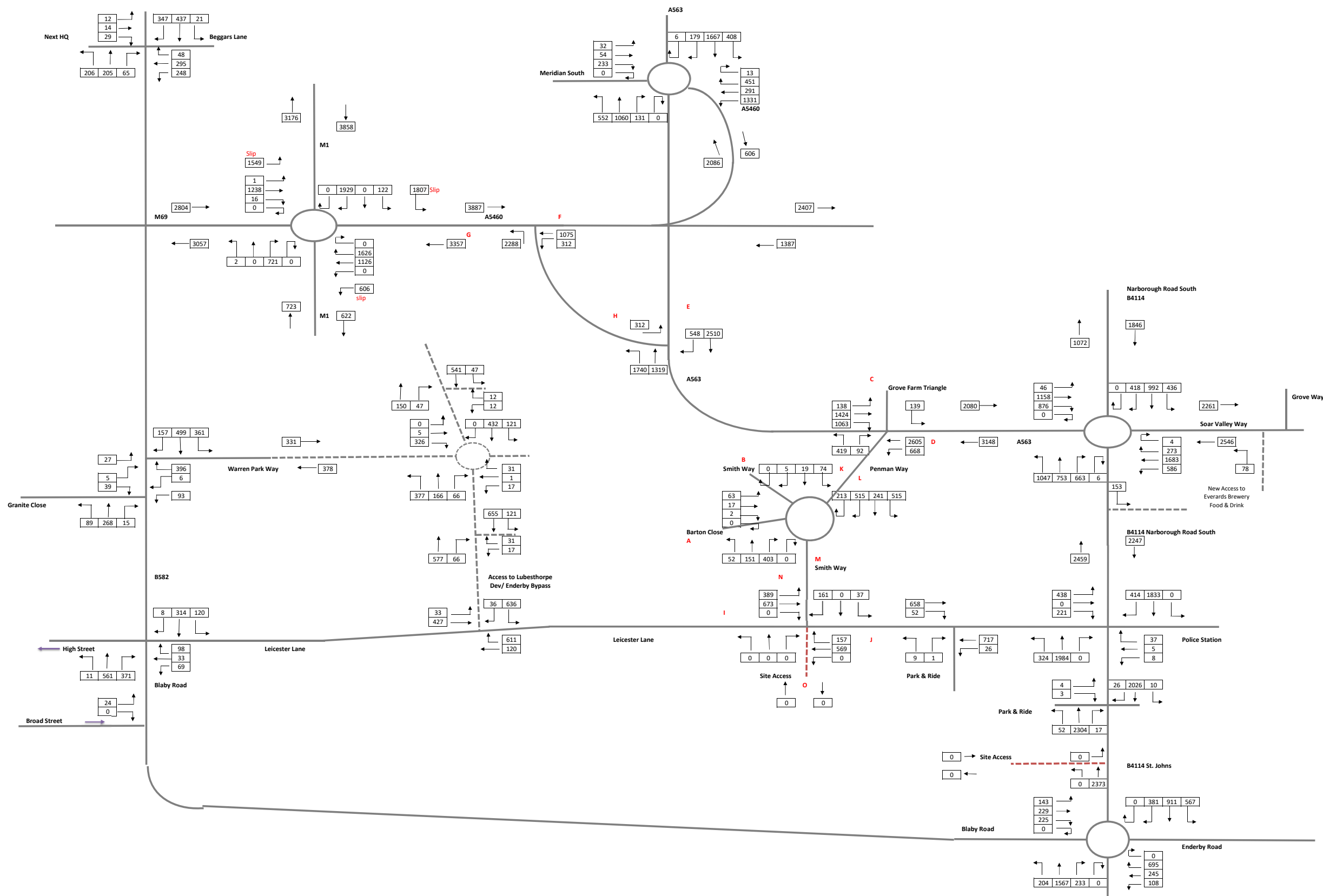

WITH ENDERBY BYPASS

Leicester Lane, Enderby
 JNY 8838
Base & Committed Traffic Flows
 AM Peak (08:00 - 09:00)
 PCU's
 WITH M69 Bridge

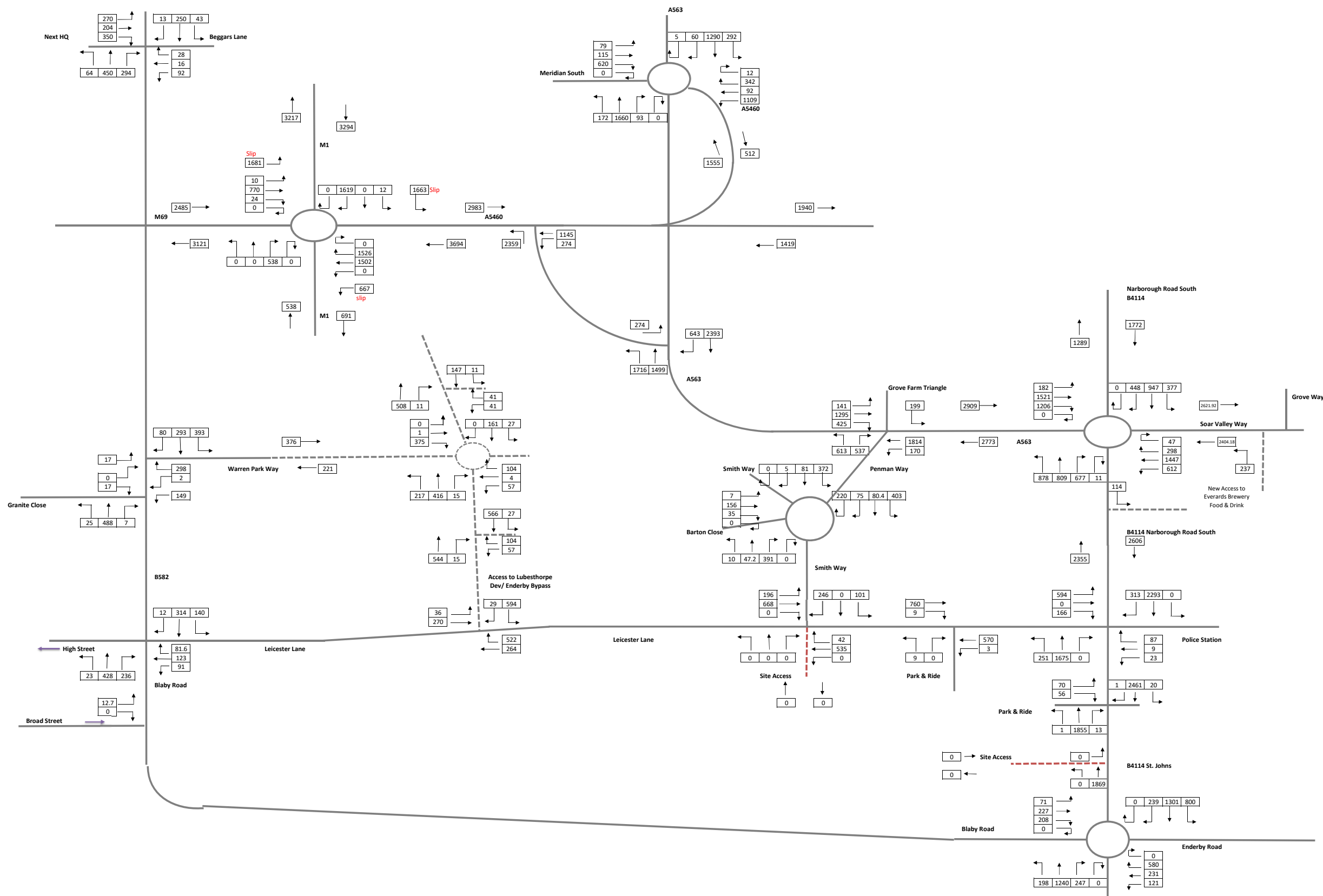

WITH ENDERBY BYPASS

Leicester Lane, Enderby
 JNY 8838
Base & Committed Traffic Flows
 PM Peak (17:00 - 18:00)
 PCU's
 WITH M69 Bridge