

New "Brentwood" Driveway Gate by Gates & Fences UK in natural finish to match existing fence complete with new matching gate posts and steel hinges, locks and handles (in either plain galvanised or antique black finish).

Existing fence with concrete posts and toe-boards and close boarded softwood panels.

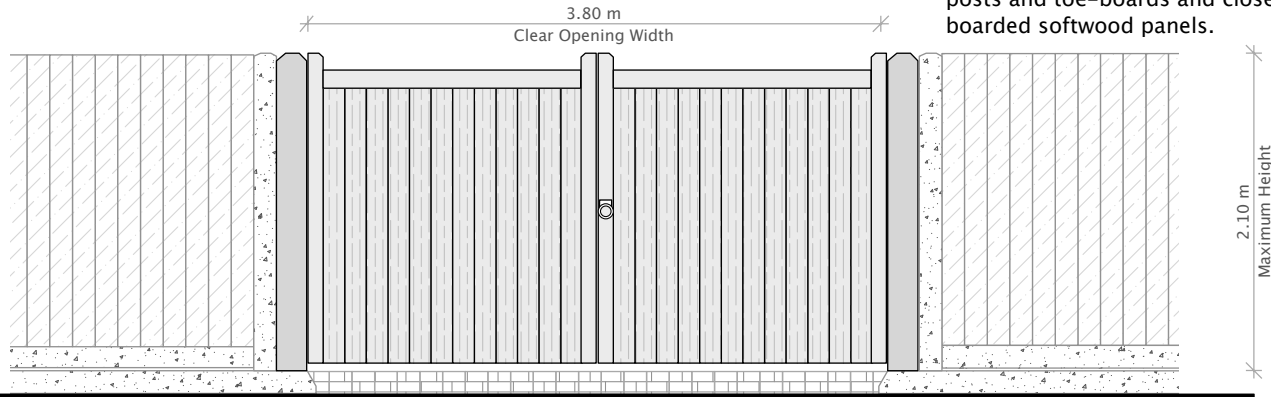

GATE ELEVATION 1:50 (From Car Park)

Existing concrete kerb to car park with new dropped-kerb access and sloping concrete-sett ramp to new driveway.

New "Brentwood" Driveway Gate by Gates & Fences UK in natural finish to match existing fence complete with new matching gate posts and steel hinges, locks and handles (in either plain galvanised or antique black finish).

Existing fence with concrete posts and toe-boards and close boarded softwood panels.

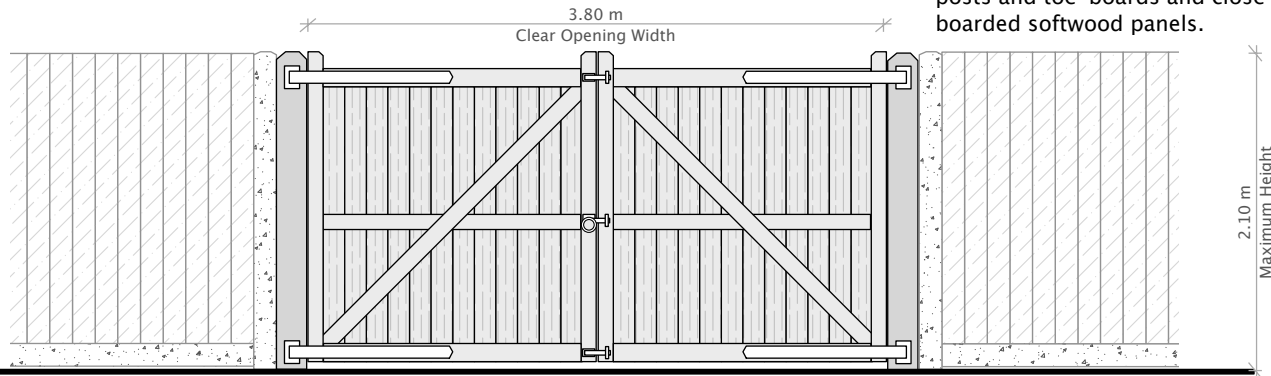

GATE ELEVATION 1:50 (From Garden / Driveway)

5c Soham Road, Fordham

Proposal for New Garage

Drawing No: 5CSR - 006

January 2021

Mr A & Mrs F Morris
5c Soham Road, Fordham

1m 2m 3m 4m 5m