

ATTIC & LOFT PLAN
Scale 1:50@ A1

Section C
Scale 1:20@ A1

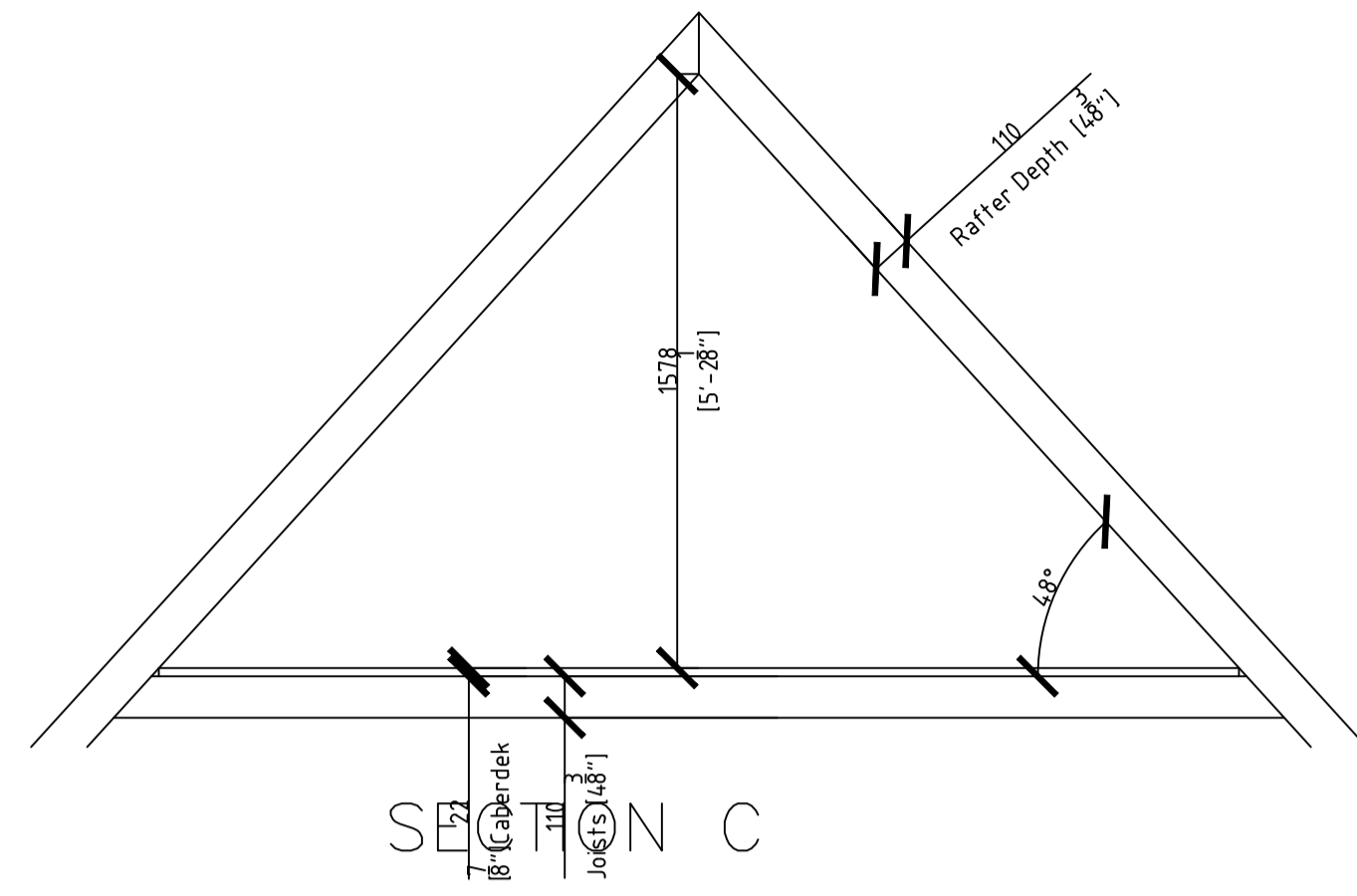

Section B
Scale 1:20@ A1

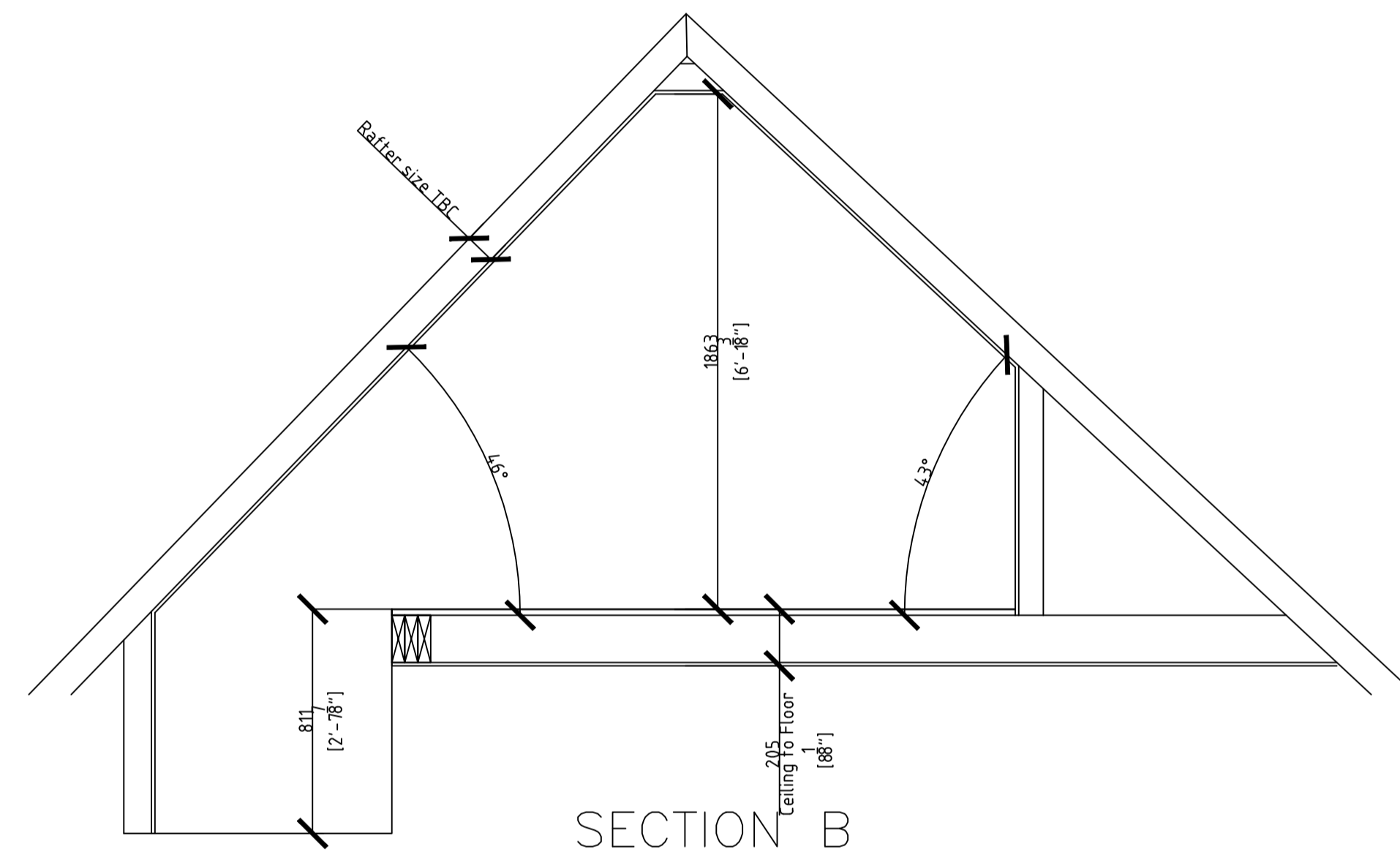

Section A
Scale 1:20@ A1

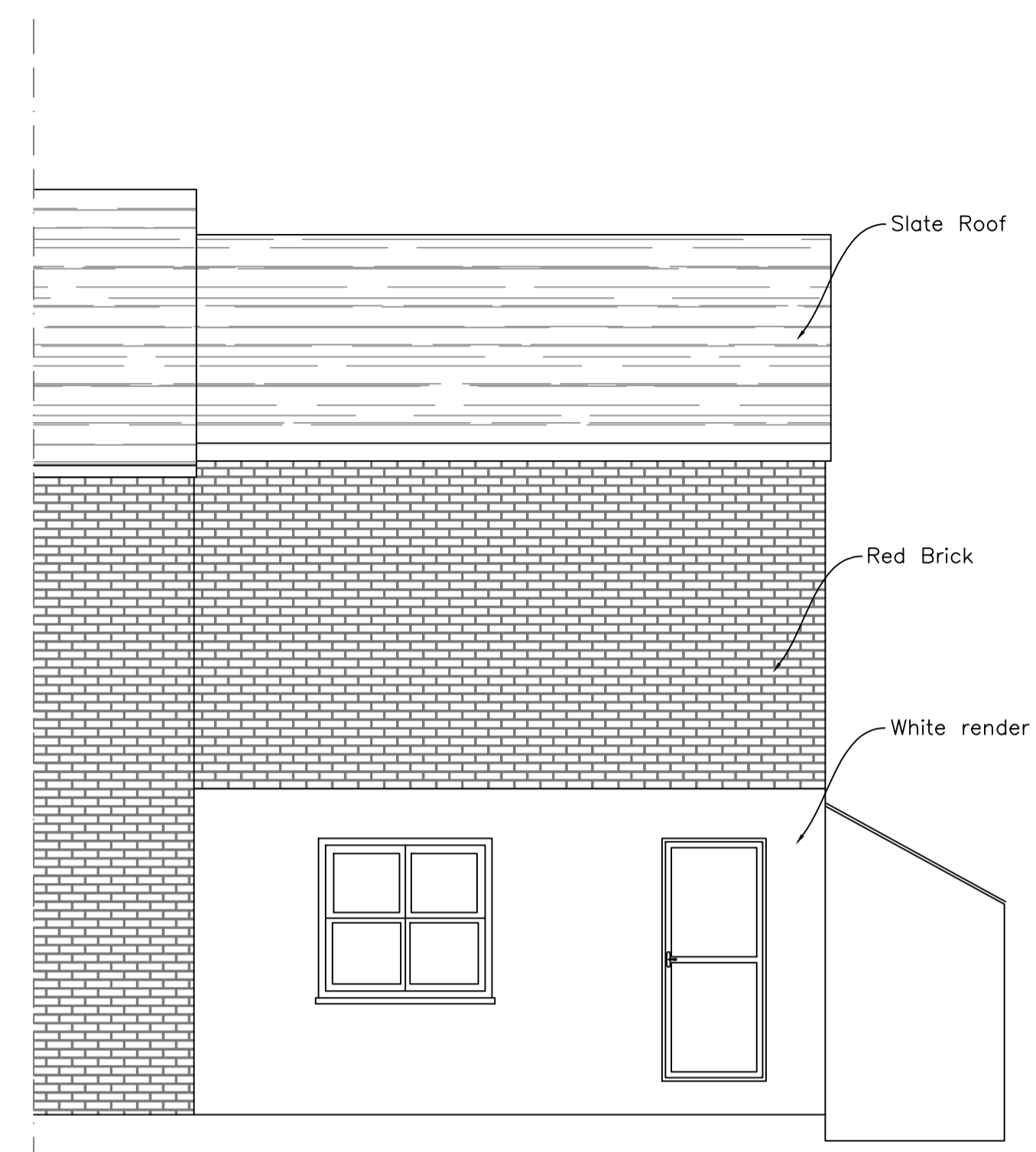
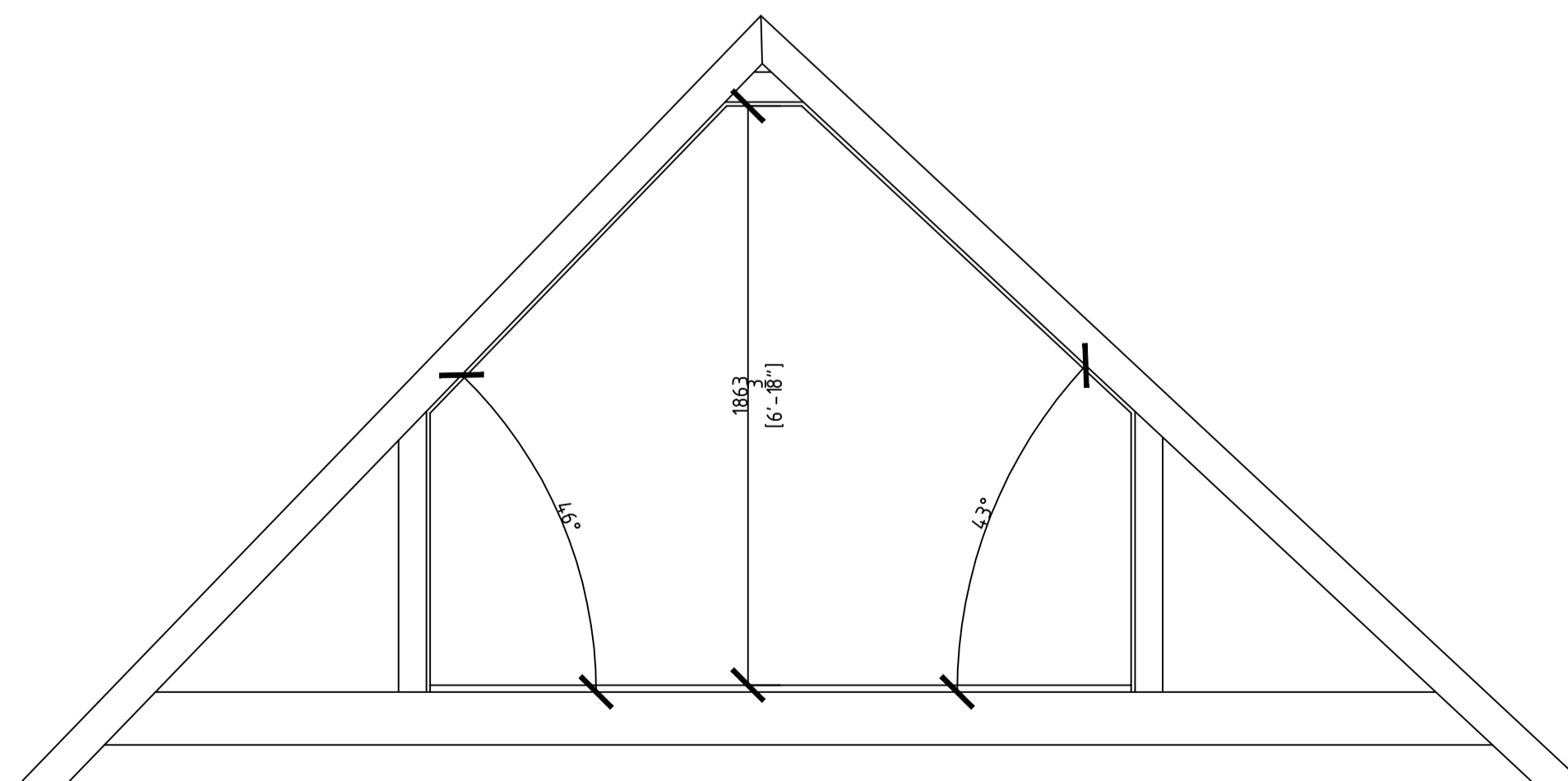

Part Side Elevation
Scale 1:50@ A1

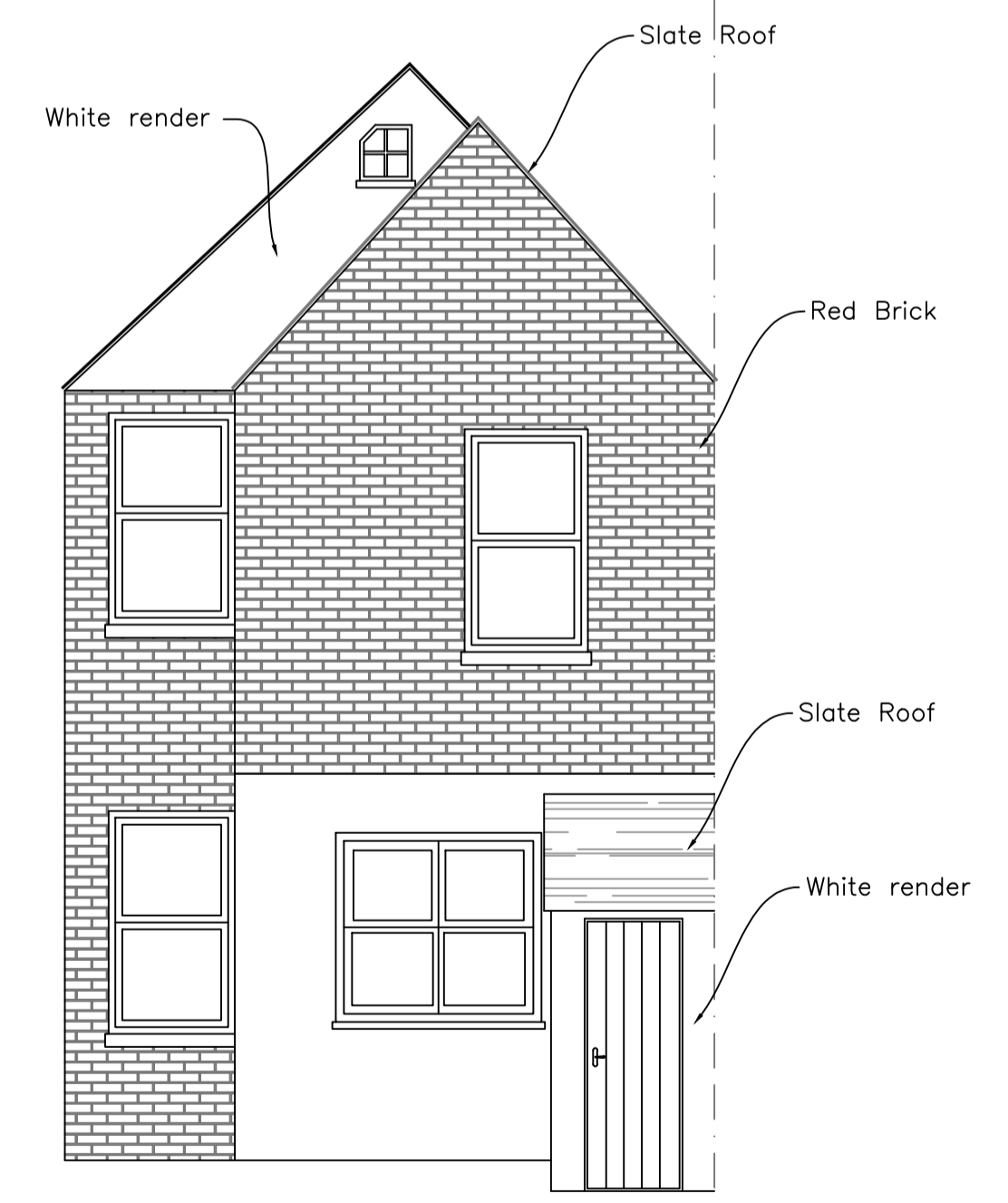

Rear Elevation
Scale 1:50@ A1

Note:
1. The Contractor is responsible for verifying all dimensions and levels on site before commencing work.
2. All given dimensions are to be taken in preference to any scaled dimensions.
3. Any dimensions shown are to be taken in preference to any scaled dimensions.
4. All work is to comply with the Building Regulations, Code of Practice, Best Practice, and the principles of good practice and construction in line with the requirements of the CDM Regulations.
5. All proposed work is to be checked and approved by Building Control prior to commencing work.
The Contractor, Design and Management Regulations 1996:
1. To comply with the CDM Regulations, the Designer has a statutory responsibility to inform the Client of any necessary obligations.
2. The Designer has a statutory responsibility to support the Planning Supervisor and the Principal Contractor for the project in the following ways:
3. The Designer has a statutory responsibility to advise the Client on whether the Regulations are applicable to the project.
4. The CDM Regulations are a statutory requirement and failure to comply with the regulations is a criminal offence.
The Party Wall etc. Act 1996:
1. If you intend to carry out building work which involves one of the following categories:
* work on an existing wall or structure shared with a neighbour
* building a new wall or structure on the boundary with a neighbour's property
* excavating near and from a neighbour's building
then you must give notice to the neighbour at an early stage of the project to identify whether the work will affect the condition of the neighbour's building and to allow them to make any necessary arrangements.
2. If you intend to carry out building work which involves one of the following categories:
* building a new wall or structure on the boundary with a neighbour's property
* excavating near and from a neighbour's building
then you must give notice to the neighbour at an early stage of the project to identify whether the work will affect the condition of the neighbour's building and to allow them to make any necessary arrangements.
Copyright:
The copyright of this drawing remains with Ben Varon Design. No reproduction or distribution is permitted without the prior permission from Ben Varon Design is permitted.

CLIENT		MR & MRS TOOGOOD	
Drawing Title		SURVEY AS EXISTING	
Drwg. No.	Rev.	Date	Drawn by
2020 / 004 / 01	D	October 2020	RN
Rev.	Description	Date	Drawn by
D	Added side elevation	Nov 2020	RN
1:50	1	2	3
1:100	1	2	3
1:200	1	2	3
1:250	1	2	3

SURVEY AS EXISTING
38 GORDON ROAD
COWES
ISLE OF WIGHT
Tel: 07894 061505