



## Shoebox Heat Pumps

### Features and Benefits

- Quiet operation
- Low running costs
- Low carbon emissions
- Ease of installation inside a dwelling
- Available in 3kW and 6kW
- Single phase
- UK manufactured
- Access to industry grants



### Product Description

The [Kensa Shoebox range of heat pumps](#) are designed to provide space heating and domestic hot water (optional extra) for well insulated buildings with multiple accommodation. By using a [communal ground array](#) this avoids the high heat losses associated with running high temperature pipe throughout buildings improving the overall efficiency of the system.

The Shoebox heat pump is designed specifically to operate with low noise levels enabling easy installation in places such as an apartment's kitchen.

The unit has been specifically designed to provide a renewable alternative for heating multiple apartment blocks. When combined with a [District Vertical Array \(D-VA\)](#) communal ground array,

Shoebox units are eligible for the [Renewable Heat Incentive \(RHI\)](#) commercial tariff.

The Shoebox heat pump is available in two sizes; a 3kW version and 6kW version. Both units come complete with the ground side water pump internal to the unit reducing the complexity of installation.

Kensa Shoebox heat pumps use low grade renewable energy from a communal borehole field and each individual apartment's heat pump concentrates this to a higher temperature to provide heat into the apartment's heating system.

As a UK manufacturer, Kensa offers a high quality product which is supported by leading industry technical support to ensure the application engineering is performed to the highest standard.



### Shoebox Heat Pumps

	Single Phase	
Nominal thermal kW rating	3.0	6.0
Part No	S3-P0K	S6-P0K
MCS Approved	BBA0055/31	BBA0055/35
<b>Performance data—rated heating output at B0/W35 BS EN14511</b>		
Power consumption	0.8kW	1.6kW
Coefficient of performance*	4.05	3.84
Immersion heater output	Kensa heat pumps do not feature back-up electric immersion heaters**	
<b>Brine (primary) based on 0°C in, -4°C out</b>		
Design flow rate kg/min	9.2	18.4
Pressure drop kPa at design flow rate	5	16
Max inlet temperature °C	25	
Min temperature °C (Outlet)	-5 (at standard settings)	
<b>Heating water (secondary) based on 30°C in, 35°C out</b>		
Design flow rate l/min	8.62	16.88
Pressure drop kPa at design flow rate	1.0	0.64
Max flow temperature °C***	65 (RHI applications 64C)	65 (RHI applications 60C)
<b>Electrical Values @B0/W35</b>		
Rated Voltage	220 – 240 V / 50-60 Hz	
Power supply rating amps	13	25
Rated current (max) amps	7	14
Typical running current @ B0/W35 amps	4	8
Starting current amps	30	34
<b>Acoustic Performance</b>		
Sound Power Level	47dBA	52dBA



Apartment Development with a DV-A Communal ground array

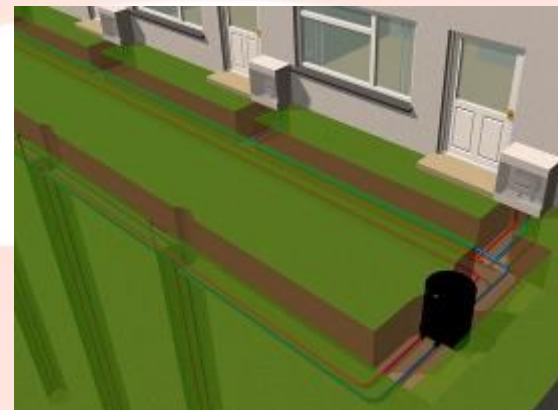

Terraced House Communal Ground Array



### Shoebox Heat Pumps

	Single Phase	
<b>Nominal thermal kW rating</b>	<b>3.0</b>	<b>6.0</b>
<b>Refrigerant circuit</b>		
Process medium	R134a	
Fill volume kg	0.7	1.6
Compressor type	Reciprocal	
<b>Nominal Dimensions</b>		
H x W x D (mm)	515 (H) X 480 (W) X 360 (D)	585 (H) X 610(W)X 595(D)
Nominal weight kg	60	100
<b>Operating pressure</b>		
Brine circuit min (primary) bar g	0.3	
Heating water circuit min (secondary) bar g	0.6	
Low pressure reset bar g	1.8	
<b>Connection sizes</b>		
Primary IN and OUT	3/4" BSP Parallel with 22mm Adaptor valves	
Heating flow and re-turn		
<b>Performance (based on Average Climate) @35°C</b>		
ErP rating	A+	A+
SCOP	3.68	3.45
Seasonal space heating energy efficiency	139%	130%
<b>Performance (based on Average Climate) @55°C</b>		
ErP rating	A+	A+
SCOP	2.99	2.97
Seasonal space heating energy efficiency	112%	111%

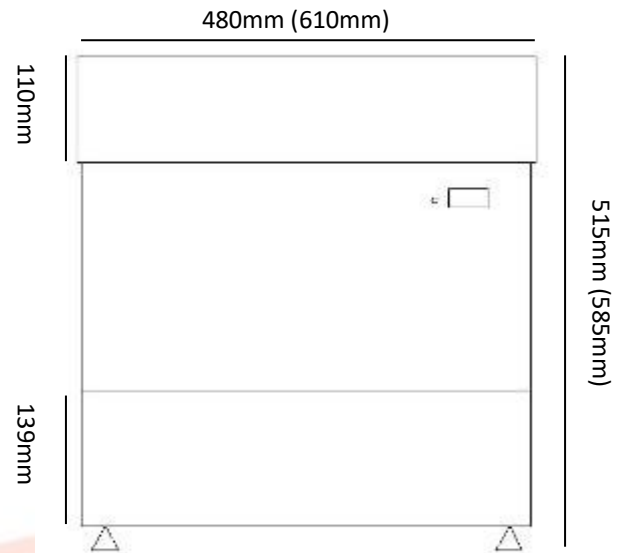

Dimensions in brackets are for the twin compressor 6kW version.

\* The COP figure quoted is calculated as per EN14511

\*\* In-built immersion heaters will increase running costs and CO2 emissions as they use direct electricity, because of this Kensa heat pumps do not include them.

\*\*\* By increasing the flow temperature from the heat pump the efficiency of the unit will drop and the COP decreases.

Note: Design flowrates are for a ground temperature of 0 and -4°C and a load temperature of 30 and 35°C



## Shoebox Heat Pumps

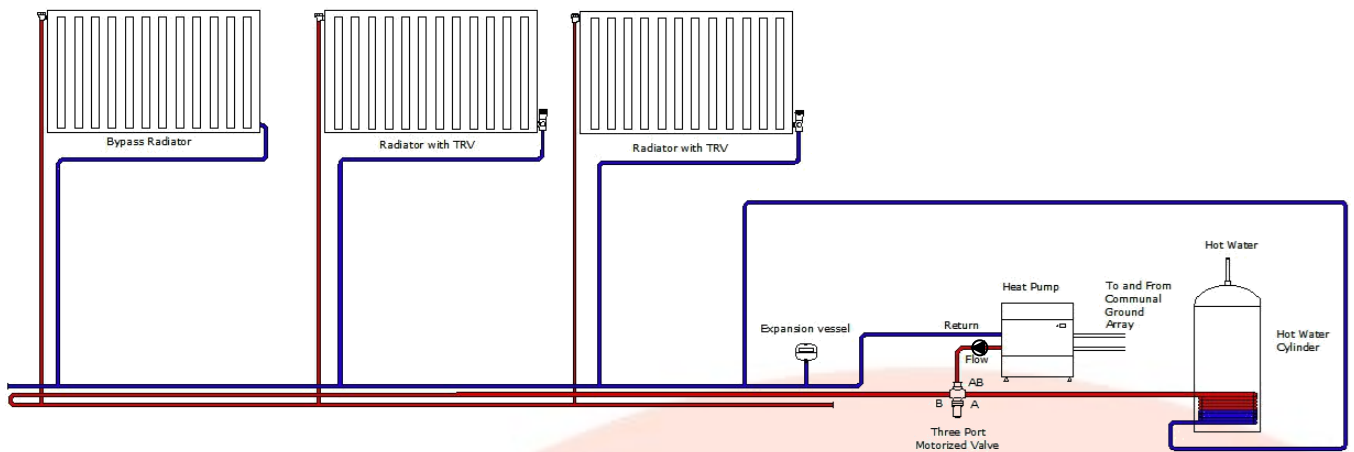

Shoebox Installation Schematic—Radiators

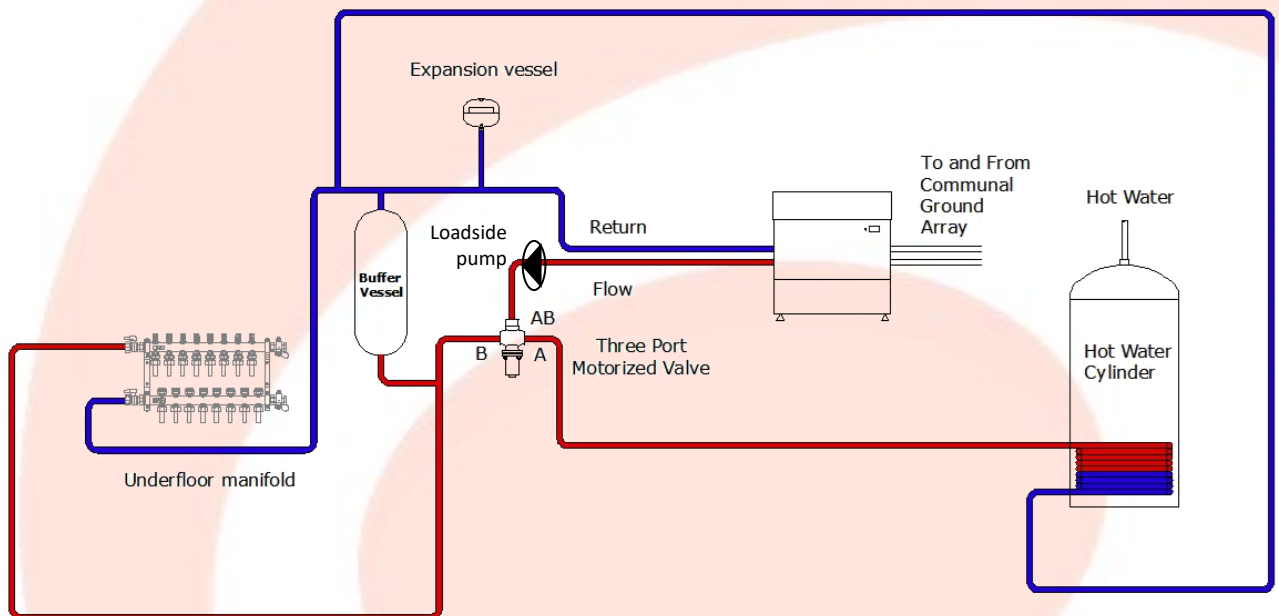

Shoebox Installation Schematic—Underfloor