

01 PROPOSED FASCIA SIGNAGE A - INTERNALLY ILLUMINATED - ILLUMINATION LEVEL - 375 cd/m²
P143059213 1:50@A3

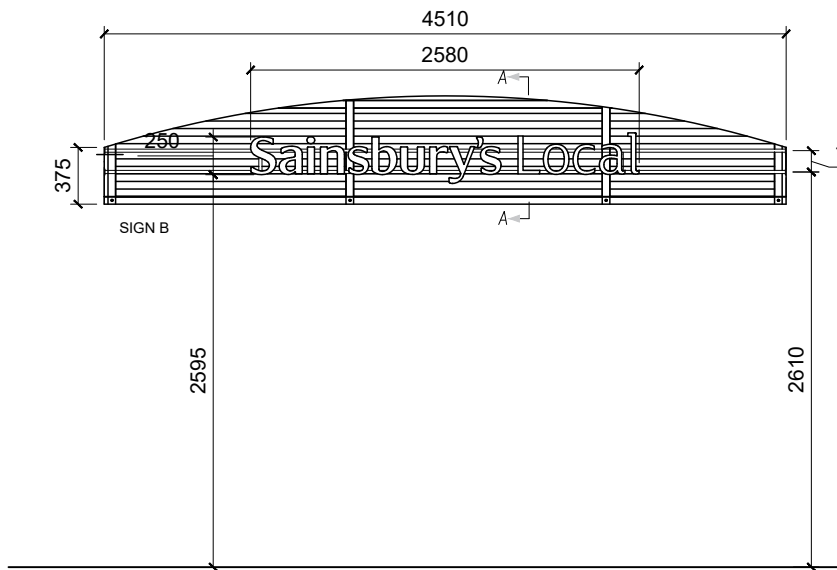

03 PROPOSED FASCIA SIGNAGE B - INTERNALLY ILLUMINATED - ILLUMINATION LEVEL - 375 cd/m²
P143059213 1:50@A3

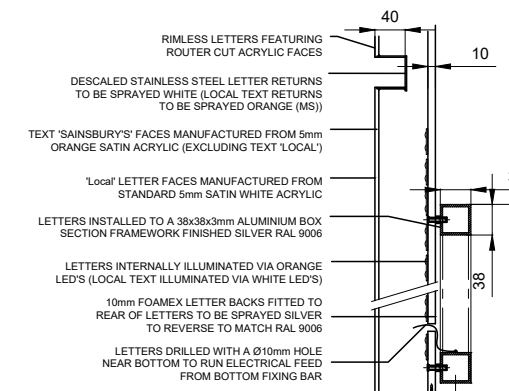

04 PROPOSED FASCIA SIGNAGE B DETAILS
P143059213 1:10@A3

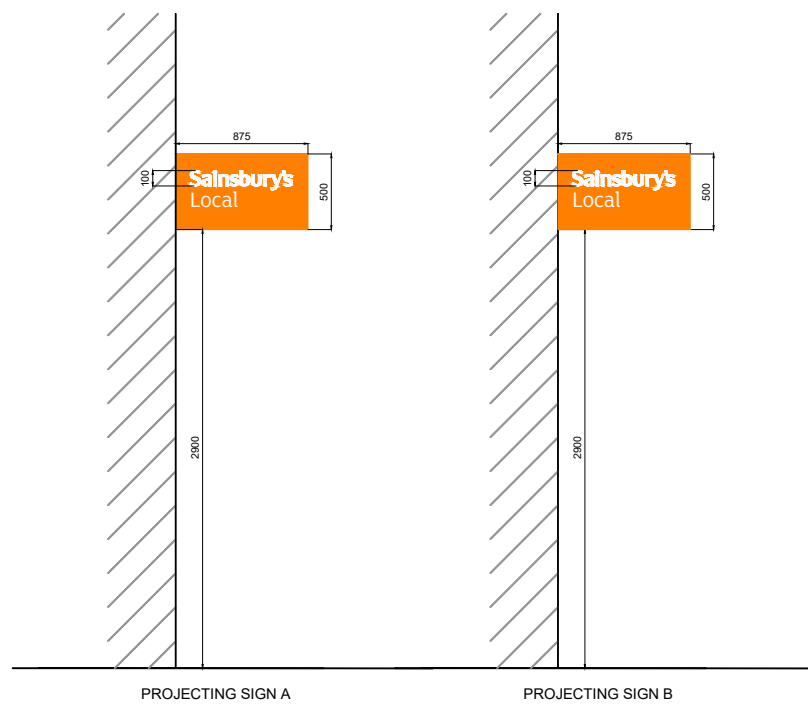

05 PROJECTING SIGNS
P143059213 1:50@A3
ILLUMINATION LEVEL - 204 cd/m²

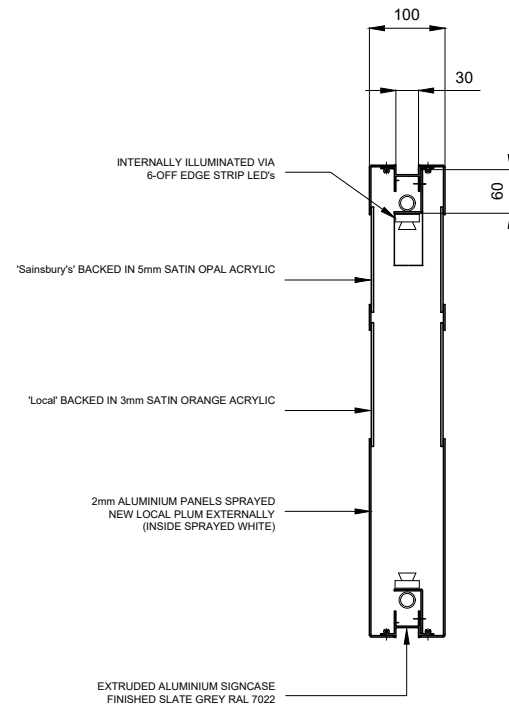

06 PROJECTING SIGN DETAIL
P143059213 1:10@A3

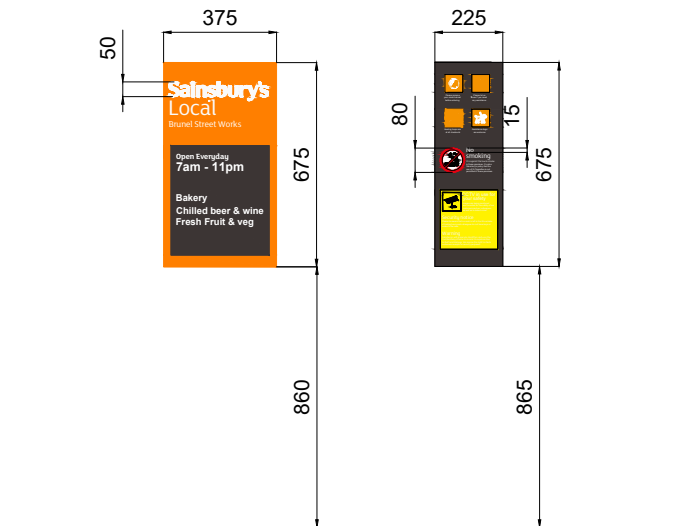

07 WELCOME MESSAGE
P143059213 1:25@A3

08 STAT SIGN
P143059213 1:25@A3

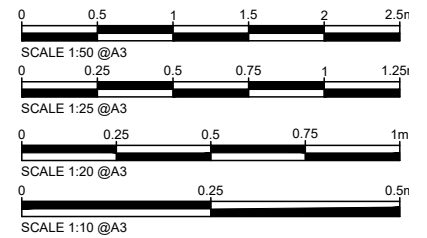

Rev.	Date	Description	
C	07.01.21	General Amendments	JN
B	05.01.21	Amend address and ATM omitted	VA
A	04.12.20	Amended to Comments	JN
--	30.11.20	First issue	JN

architects
project managers
cost consultants

jla

2nd Floor
13 Swan Yard
Islington, London
N1 1SD
tel: 0203 637 8800

Status

Project Title
SAINSBURY'S LOCAL
23 SILVERTOWN WAY
CANNING TOWN, LONDON E16 1DH

Drawing Title
PROPOSED SIGNAGE DETAILS

Project Number P-143059	Drawing Number P-143059-213	Revision C
Drawn JN	Checked VA	Scale Varies
Date 30.11.20		

JLA Architects is a trading name of Company Ref: OC315406 registered in England and Wales Registered Office: Euro House, 138 High Road, London, E9 7TZ. Any reproduction of all or any part of this drawing without formal consent of the copyright owner, Company Ref: OC315406, is prohibited. The content of this drawing is the property of the Company Ref OC315406.