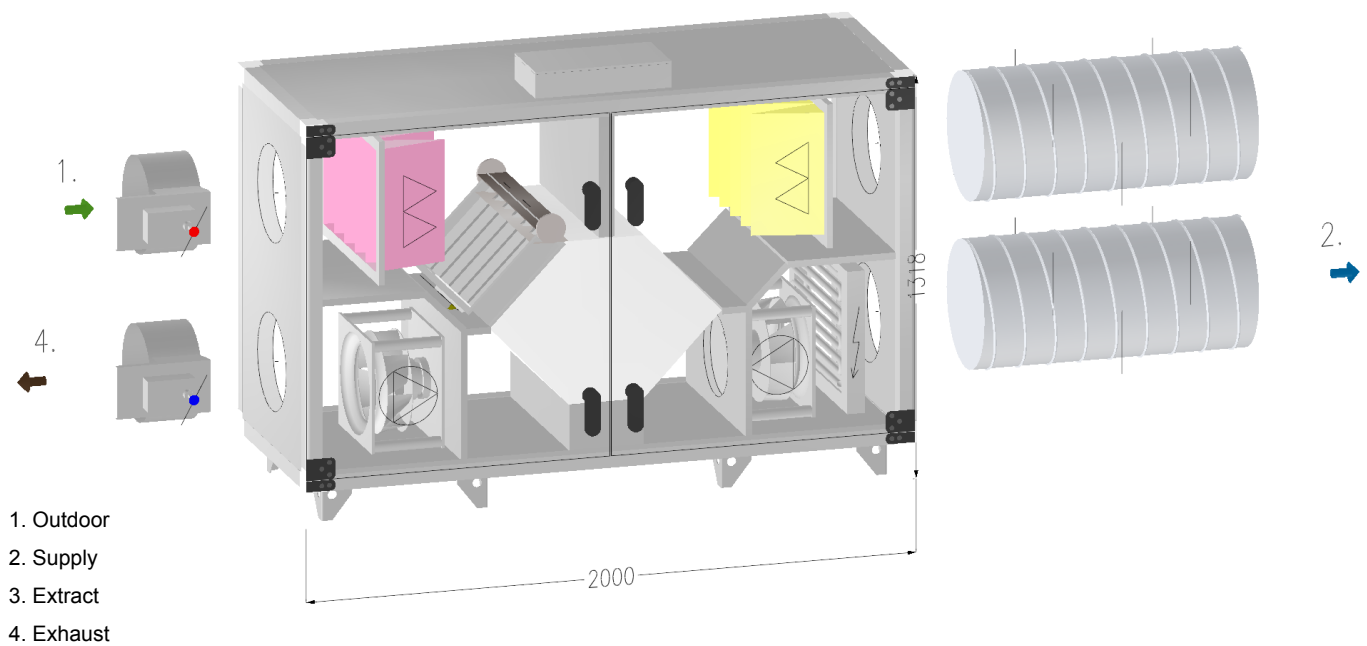

Topvex SC20-R-EL4,2-B (162123)

Total weight: 271 kg

Width: 750 mm

 Duct connection: \varnothing 315 mm

Air data	Supply air	Extract air	Units
Airflow (1.205 kg/m ³)	0.25	0.25	m ³ /s
Face velocity (unit)	0.8	0.8	m/s
External pressure	150	150	Pa
Fan speed	2,254	2,271	rpm
Filter	ePM1 60% (F7)	ePM10 60% (M5)	
Sound break out	43 dB (A)		
Design outdoor temperature	-5.0 °C		
Heating, electric	1.29 kW ; 16.8/21.0°C ; 3x400V		
Energy			
Heat recovery (EN 308)	84.5		%
SFPv, clean filter pressure drop	1,303		W/(m ³ /s)
Ecodesign 2018 approved	Yes		

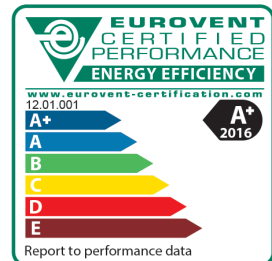

Project name Inverclyde Council HQ Offices

AHU 01 PHE Option

Project number

9/8/2020

Page 2 / 16

Unit data	
Item number	162123
Unit name (optional)	AHU 01 PHE Option
Notes	
Total weight	271 kg
Eurovent energy class	A+

Ecodesign	
Trade name	Systemair
Product name	Topvex SC20
Fulfills Ecodesign 2018	Yes
Unit category	NRVU
Unit type	BVU
Drive	Integrated VSD
Heat recovery type	Recuperative
Temperature ratio	83.4 %
Nominal airflow	0.30 m ³ /s
P nom	489 W
SFP int	928 W/(m ³ /s)
Face velocity	1.0 m/s
Nominal pressure	200 Pa
Ps int. Supply	260 Pa
Ps int. Extract	264 Pa
Supply fan efficiency	56.5 %
Extract Fan efficiency	56.6 %
External leakage	2 %
Internal leakage	1 %
Sound power level (LwA)	47 dB (A)

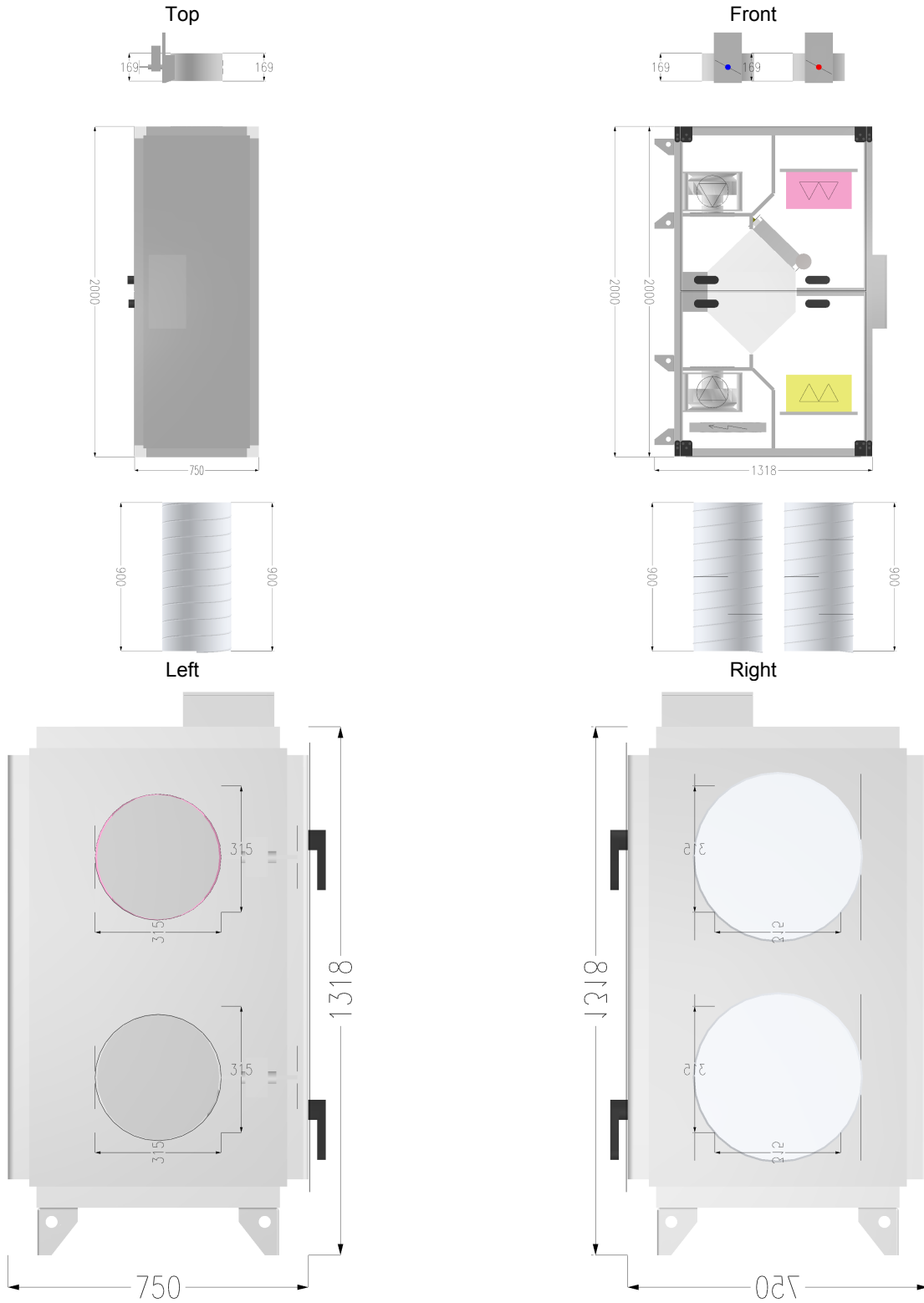

Air and sound

Winter & Summer

Supply

Extract

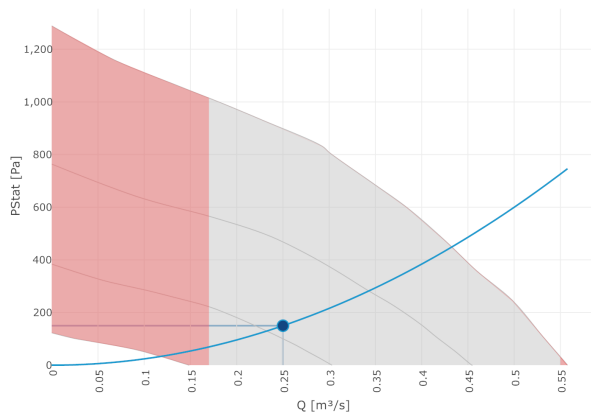
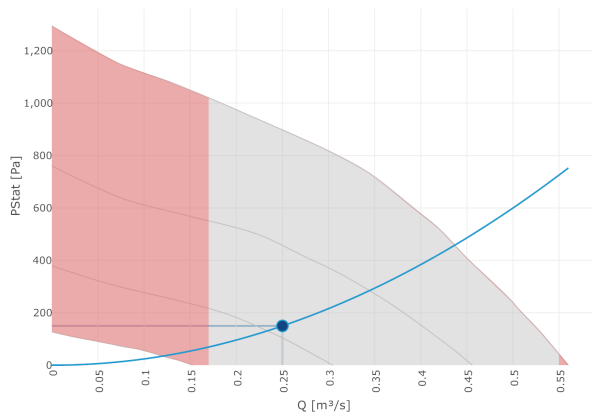

	Octave bands [Hz]								Total [dB(A)]
	63 [dB]	125 [dB]	250 [dB]	500 [dB]	1k [dB]	2k [dB]	4k [dB]	8k [dB]	
Sound power level									
Supply	41	51	48	41	35	43	41	34	48
Outdoor	36	51	37	40	40	35	29	18	44
Extract	34	52	40	25	17	21	25	17	38
Exhaust	43	57	62	62	58	56	52	46	64
Surrounding	21	47	43	36	35	38	34	27	43

Project name Inverclyde Council HQ Offices

AHU 01 PHE Option

Project number

9/8/2020

Page 5 / 16

Casing

Casing name	Topvex
Insulation	50 mm mineral wool
Internal and external sheet metal thickness	0.7 - 2 mm
Single or double skin	Double
Corrosion protection	Class C5 according to EN ISO 12944-2:2000
Classifications	EN 1886:2007
Mechanical strength	Class D2 (R)
Casing air leakage	-400Pa: Class L2(R) +400Pa: Class L2(R)
Filter by-pass air leakage	-400Pa: Class F9(R) +400Pa: Class F9(R)
Thermal Transmittance	Class T2 (R)
Thermal Bridging	Class TB2 (R)

Control cabinet

Air volume control	CAV
Main power supply	3x400V
External communication	Modbus / Exoline via RS485, Modbus / Exoline / Built in WEB via TCP/IP, BACnet via IP
Temperature control	Cascaded Extract Air Control
Language in controller menu	Select local language by startup
Recommended fuse	3x16 A

Note

Supply air side

Outdoor - Damper

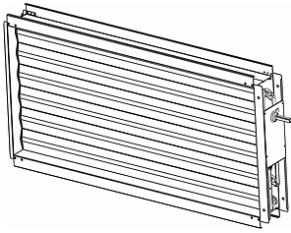

Model Tune-R-315-LF24

Item number 79890

Note

	Winter	Summer	
Pressure drop	0	0	Pa

Outdoor - Duct connection

Item number

Dimension Ø 315 mm

Note

	Winter	Summer	
Air temperature	-5.0	28.0	°C
Air relative humidity	100	40	%
Air flow	0.25	0.25	m³/s

Outdoor - Filter

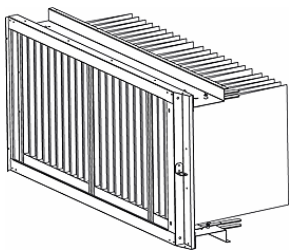

Model BFT SC20 Filter Sup. PM1 60%

Filter type Bag Filter

Class ePM1 60% (F7)

Length 270 mm

Width 635 mm

Height 470 mm

Required number of filters 1

Note

	Winter	Summer	
Initial pressure drop	40	40	Pa
Design pressure drop	94	94	Pa
Terminal pressure drop	147	147	Pa
Face velocity	0.8	0.8	m/s
Energy performance	268	268	W

Plate heat recovery

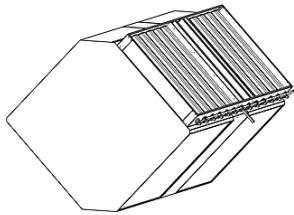
 Section defrosting No

Note

Product code

	Winter	Summer	
Supply latent efficiency	87.0	84.4	%
Dry efficiency according to EN 308 (balanced airflows)	84.5	84.5	%
Supply pressure drop, calculated at actual density	114	114	Pa
Extract pressure drop, calculated at actual density	122	114	Pa
Total duty	6,602	1,571	W
Condensate	1.69	0.00	kg/h
Supply temperature before/after	-5.0 / 16.8	28.0 / 22.9	°C
Supply RH before/after	100 / 22	40 / 54	%
Extract temperature before/after	20.0 / 2.3	22.0 / 27.1	°C
Extract RH before/after	40 / 95	40 / 30	%

Supply - EC Fan

 Type of drive Direct drive

 Fan type High Efficiency

 Impeller type Plastic/Composite

 Motor protection Thermistor

 Max. temperature of transported air 60.0 °C

 Max. temperature of transported air when voltage-controlled 60.0 °C

Note

Rated voltage

	Winter	Summer	
Volume flow	0.25	0.25	m³/s
External static pressure	150	150	Pa
Internal static pressure	250	250	Pa
Total static pressure. The pressure drop of the fan is calculated as a part of the static pressure drop for the complete unit.	400	400	Pa
Power	190	190	W
Speed	2,254	2,254	rpm
SFP	761	761	W/(m³/s)
Total efficiency by total pressure, incl. motor and speed control	52.6	52.6	%

Supply - Electric coil

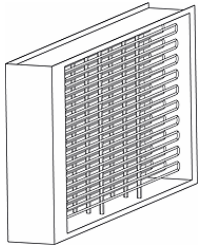

Voltage	3x400 V
Capacity	4.2 kW
Note	

	Winter	
Air flow	0.25	m ³ /s
Inlet air temperature	16.8	°C
Outlet air temperature	21.0	°C
Requested outlet air temperature	21.0	°C
Nominal capacity	4,200	W
Outlet absolute humidity	2.59	g/kg
Inlet absolute humidity	2.59	g/kg
Power output	1,288	W
Power output [%]	31	%

Supply - Duct connection

Item number	
Dimension	Ø 315 mm
Note	

	Winter	Summer	
Air temperature	21.0	22.9	°C
Air relative humidity	17	54	%
Air flow	0.25	0.25	m ³ /s

Supply - Sound attenuator

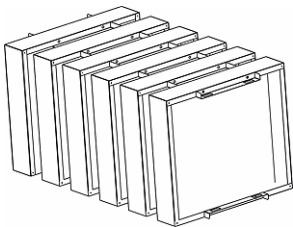

Model	LDC-315-900
Weight	16 kg
Dimension	415 x 900 mm
Item number	5197
Note	

	Winter	Summer	
Pressure drop	1	1	Pa

Extract air side

Extract - Sound attenuator

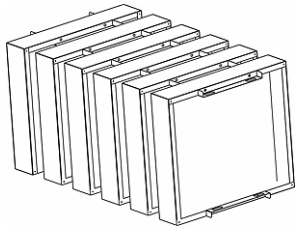

Model	LDC-315-900
Weight	16 kg
Dimension	415 x 900 mm
Item number	5197

Note

	Winter	Summer	
Pressure drop	1	1	Pa

Extract - Duct connection

Item number	
Dimension	Ø 315 mm
Note	

	Winter	Summer	
Air temperature	20.0	22.0	°C
Air relative humidity	40	40	%
Air flow	0.25	0.25	m³/s

Extract - Filter

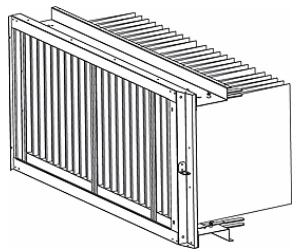

Model	BFT SC20 Filter Exh. PM10 60%
Filter type	Bag Filter
Class	ePM10 60% (M5)
Length	270 mm
Width	635 mm
Height	470 mm
Required number of filters	1
Note	

	Winter	Summer	
Initial pressure drop	27	27	Pa
Design pressure drop	80	80	Pa
Terminal pressure drop	134	134	Pa
Face velocity	0.8	0.8	m/s
Energy performance	224	228	W

Plate heat recovery

Data - see supply air side

Exhaust - EC Fan

Type of drive	Direct drive
Fan type	High Efficiency
Impeller type	Plastic/Composite
Motor protection	Thermistor
Max. temperature of transported air	60.0 °C
Max. temperature of transported air when voltage-controlled	60.0 °C
Note	
Rated voltage	

	Winter	Summer	
Volume flow	0.25	0.25	m³/s
External static pressure	150	150	Pa
Internal static pressure	260	252	Pa
Total static pressure. The pressure drop of the fan is calculated as a part of the static pressure drop for the complete unit.	410	402	Pa
Power	191	191	W
Speed	2,271	2,271	rpm
SFP	763	763	W/(m³/s)
Total efficiency by total pressure, incl. motor and speed control	53.7	52.7	%

Exhaust - Duct connection

Item number	
Dimension	Ø 315 mm
Note	

	Winter	Summer	
Air temperature	2.3	27.1	°C
Air relative humidity	95	30	%
Air flow	0.25	0.25	m³/s

Project name Inverclyde Council HQ Offices

AHU 01 PHE Option

Project number

9/8/2020

Page 11 / 16

Exhaust - Damper

Model Tune-R-315-LF24

Item number 79890

Note

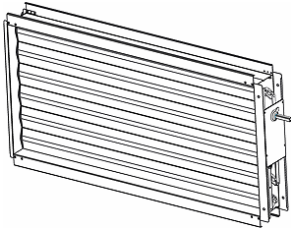

	Winter	Summer	
Pressure drop	0	0	Pa

Project name Inverclyde Council HQ Offices

AHU 01 PHE Option

Project number

9/8/2020

Page 12 / 16

Accessories

LDC 315-900 Silencer

Item number	5197
-------------	------

Quantity	2
----------	---

TUNE-R-315-3-LF24

Item number	79890
-------------	-------

Quantity	2
----------	---

Integrated control system, Systemair Access

The air handling unit is built with a complete and fully integrated control system - based on the Access control unit mounted in the control cabinet and the NaviPad user interface. The air handling unit can either run stand alone or handled from a building management system. Before shipment the unit has been assembled and has passed a final functional test and inspection. Set-up and parameters are stored in the control unit during this process.

Flow chart

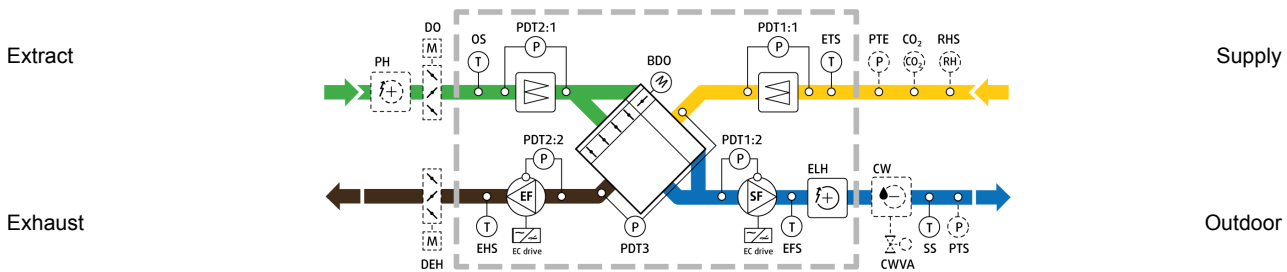

BDO	Bypass damper outdoor air	CO2	CO2 sensor	CW	Cold Water cooler
DEH	Damper Exhaust air	DO	Damper Outdoor air	EF	Extract Fan
EFS	Efficiency sensor	EHS	Exhaust air temp. Sensor	ELH	Electric Heater
ETS	Extract air temp. Sensor	OS	Outdoor air temp. Sensor	PTE	Pressure Transmitter Extract air fan
PTS	Pressure Transmitter Supply air fan	RHS	Relative Humidity Sensor	SF	Supply Fan
SS	Supply air temp. Sensor	PDT1:1	Extract air filter pressure	PDT1:2	Supply air fan pressure
PDT2:1	Supply air filter pressure	PDT2:2	Extract air fan pressure	PDT3	Heat exchanger pressure, extract air
PH	Pre-heater, electric	CWVA	Cooler water valve		

Control cabinet and mains supply

The cabinet holds necessary components including terminal blocks, fuses, 24VDC power supply and the Access control unit. On site mains power supply must be connected to the cabinet. The installer on site has full responsibility to ensure that any unit/installation which requires additional protection of the mains power supply is all carried out according to local statutory requirements. The supply disconnecting safety switch for the unit is not included.

External electrical components

Temperature sensor for the supply air duct, is delivered with the unit and must be connected to the terminals in the cabinet by the installer on site. The control cabinet design is prepared for connection of delivered components and any extra sensors that could be needed.

Depending on the customer's choice, external components are delivered, such as:

- pressure transmitters in ducts for pressure control
- valve for heating and circulation pump for heating coil

User interface with 3 m cable is not connected to control unit.

Access Control unit and NaviPad user interface

The Access NaviPad with a 7" IPS touch panel is connected by cable (3m) to the Access CU27-C acontrol unit in the cabinet. All normal handling and configuration is carried out from the graphical user interface in the NaviPad. The protection class of the NaviPad is IP 54, but not for outdoor mounting. The communication between the user interface and the control unit in the cabinet is possible with up to 100 meters of cable. The installer must use Standard Ethernet cable (CAT5/6) LAN network cable for extension. If several units are connected to a local network (on the same subnet), the NaviPad will be able to connect and monitor up to nine units. Please see separate instruction for details.

Access rights/passwords

There are 3 different log-on levels

- End user – (no password) – access to read values and to change end-user relevant settings displayed on homepage.
- Operator level – (password) – access to read values and to change user relevant settings concerning schedules, temperature, air flow and to acknowledge alarms.
- Service level (password) – access to change configuration values, access to activate new functions, or restore factory settings.

Alarms and safety functions

If an alarm condition occurs, a circular light appear at the home button on the NaviPad.

- Fixed green — Status ok (no active alarms).
- Flashing red — Active/returned alarms in one or many control units.
- Fixed red — Acknowledged alarms in one or many control units, alarms not reset

Alarms are logged in an alarm list. The list shows the type of alarm, date and time for the alarm and alarm class:

Class A alarm

Needs to be acknowledged

Class B alarm

Needs to be acknowledged

Class C alarm

Returns when the cause of the alarm disappear

Flexible System

A technician will be able to adapt the regulation further to the requirements of the users;

- The air flow regulation can be changed between several methods that are constant air volume through the fans, constant pressure in the ducts, CO2 dependant control or humidity dependant control.
- The temperature control mode can be changed between room temperature control, supply air temperature control and outdoor compensation of the selected temperature etc.
- In addition to the fixed schedule, an external start signal for extended operation is available, 3 levels
- In addition or as an alternative to the fixed schedule, an external stop input signal is available.
- A large number of other alternative functions are also optional.

Communication options

The control unit includes hardware and ports that can later be programmed by a technician according to demands from the user for two alternative methods that are;

- Communication to BMS via MODBUS RTU, TCP/IP or RS485
- Communication to BMS via BACnet IP

Heat exchanger

The capacity of the heat exchanger is stepless via modulating control.

Supply fan with EC motor

The supply air fan is driven by an EC motor with the impeller mounted directly on the motor shaft. All parameters have been configured and tested from factory.

Extract fan with EC motor

The extract air fan is driven by an EC motor with the impeller mounted directly on the motor shaft. All parameters have been configured and tested from factory.

Project name Inverclyde Council HQ Offices
Project number

AHU 01 PHE Option
9/8/2020
Page 15 / 16

Electric heater

Modulated time proportional control of the electric heater is placed in the cabinet next to the heater, in the same section as the heater. The control unit in the cabinet delivers a 0-10 VDC signal for control signal for the heater capacity.

Prepared for control of heating coil

The unit is delivered with heating battery, and without valve and modulating valve motor.

The control unit is prepared for control of valve motor, and signal as well as power for valve motor is available from terminals in the switchboard, a 0-10 V DC signal and power 24VDC.

Terminals for 230 VAC circulation pump are available in the control cabinet. The pump for the heating circuit will always run when the outdoor temperature is lower than a settable value (+10 °C). At higher outdoor temperatures the pump will run when the heating output is larger than 0 %. The pump has a settable, shortest running time and the pump will use a pump-kick once daily at 3 p.m.

Pump is not included in the delivery.

Freeze protection of the heating coil water temperature sensor

For freeze protection, the water temperature in the coil is transmitted to the control unit by a temperature sensor in a water return circuit of the coil. The control unit always generates a signal to the valve motor that keeps a sufficient flow of hot water to protect the coil against frost. This freeze protection is also activated when the running mode is "off".

If the water temperature falls below the set point temperature the fans stop, the dampers close, and an alarm is activated.

Filter monitoring

Filter monitoring over bag filters are modulated. Pressure limit is depending on the flow. Low flow = low pressure limit, high flow = high limit. Transmitters are connected to the control unit. From the display you can see actual pressure and set limits for alarm. Transmitters placed as indicated in flow chart.

Cooling recovery

If the extract air temperature is lower than the outdoor air temperature, and there is a cooling demand in the rooms, the cooling recovery will be activated. The heat exchanger signal is reversed to give increasing cooling recovery on increasing cooling demand.

Constant supply air

• The control of the supply air temperature is based on the value from the sensor mounted in the supply air duct.

The supply air temperature is controlled by a PID-regulator (PID control loop). The set-point for the supply temperature can be adjusted from the control panel. The supply air temperature is kept at the set-point value by control of the heat exchanger, heating coil and cooling coil demand. The control of all capacities is fully modulating.

Outdoor compensated supply air

Control of the supply air temperature is based on the values from 2 temperature sensors:

- A sensor inside the unit at air intake, giving the outdoor temperature. Optional an outdoor wall mounted sensor can be selected.
- A sensor mounted in the supply air duct.

The supply air temperature is controlled by a PID-regulator and the set-point is outdoor air temperature compensated using a control curve with 4 points. The 4 curve points can be adjusted from the control panel. The supply air temperature is kept at the setpoint value by controlling the capacity of the heat exchanger, heating coil and cooling coil. The control of all capacities is fully modulating.

Outdoor dependent supply or room temp

When the outdoor temperature is lower than a settable value (winter) outdoor compensated supply air temperature control will be active, otherwise when the outdoor temperature is above this settable value (summer), cascaded room temperature control will be active.

Cascaded room temperature control

The control of the supply air temperature is based on the values from 2 temperature sensors:

- A sensor in the room, optional up to 4
- A sensor in the supply air duct.

The supply air temperature is controlled by a cascaded room temperature regulator to achieve a constant, settable room temperature. The set points for the room temperature as well as the temperature limits for the supply air temperature can be adjusted from the control panel. The output from the room temperature PID-loop controls the supply air temperature. The set-point value is achieved by controlling the capacity of the heat exchanger, heating coil and cooling coil. The control of all capacities is fully modulating.

Project name Inverclyde Council HQ Offices

AHU 01 PHE Option

Project number

9/8/2020

Page 16 / 16

Cascaded extract temperature control

The control of the supply air temperature is based on the values from 2 temperature sensors:

- A sensor inside the extract section giving the mixed average temperature from the rooms
- A sensor installed by the installer in the supply air duct.

The supply air temperature is controlled by a cascaded room temperature regulator to achieve a constant, settable extract temperature. The set points for the extract temperature as well as the temperature limits for the supply air temperature can be adjusted from the control panel. The output from the room temperature PID-loop controls the supply air temperature. The set-point value is achieved by controlling the capacity of the heat exchanger, heating coil and cooling coil (if installed). The control of all capacities is fully modulating.

Air flow control

The air flow rates of supply and extract air are controlled separately. The supply and extract air at Normal, low and high airflow in m³/h are set separately on the control panel.

On each fan a pressure transducer measures the difference between the pressure before the fan and the pressure at the measuring probe in the inlet cone. Through a formula with a factor for each fan size, the output signal from the pressure transducer is used to calculate the actual airflow in m³/h. Optional other units can be selected as well.

A PID-regulator maintains the set point value by controlling the speed of the fans.

Constant duct pressure

The air pressure of supply and extract air are controlled separately. The supply and extract air at Normal, low and high air pressure in Pa are set separately on the control panel. The air pressures are measured by pressure transducers in supply and exhaust air duct.

A PID-regulator maintains the set value by controlling the speed of the fans.

The actual supply and extract air flows are available for read out

External pressure transmitters are not included in the delivery.