

PROFILES 1:1

DOOR LEAF

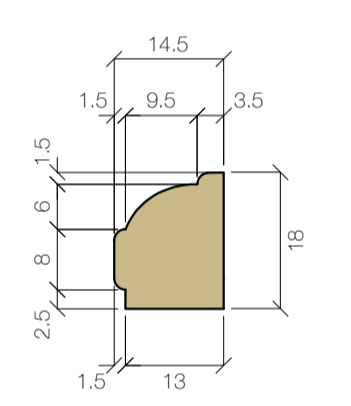

BEADING
14.5x18 FINISH SIZE

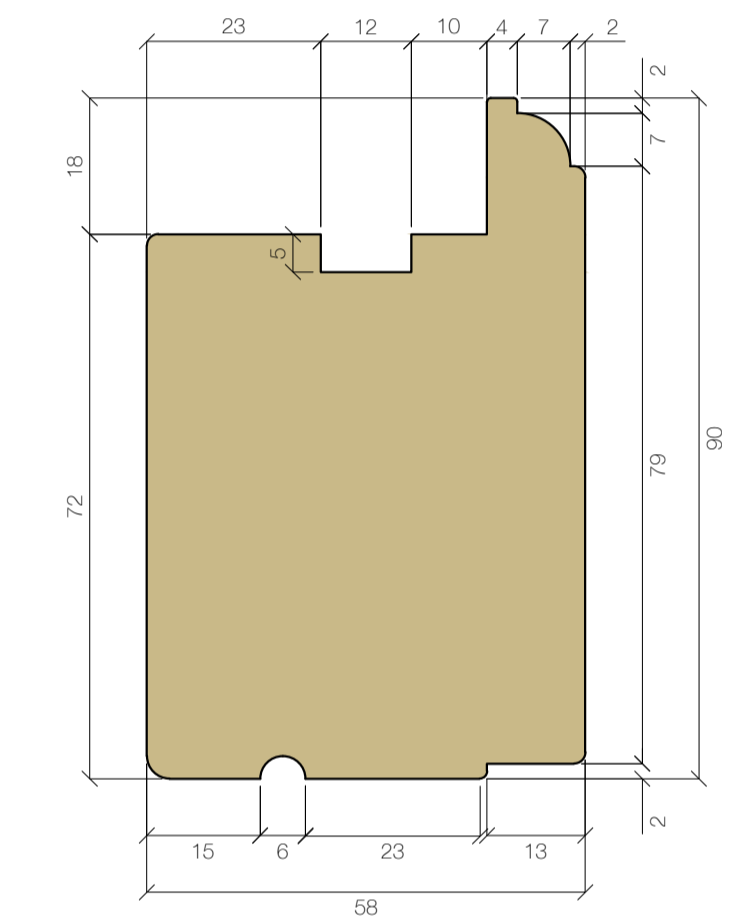

STILE
58x90 FINISH SIZE

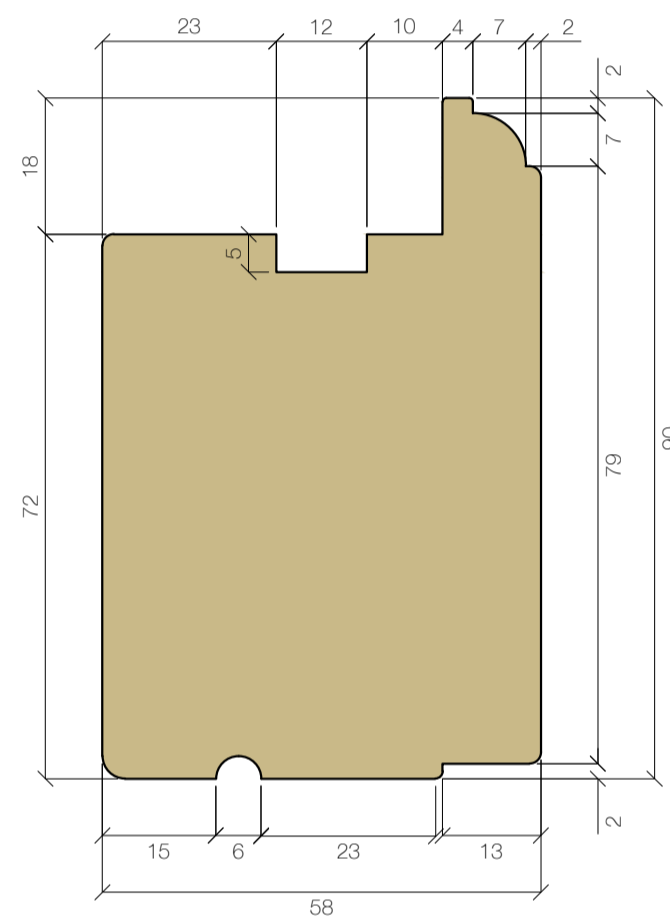

TOP RAIL
58x90 FINISH SIZE

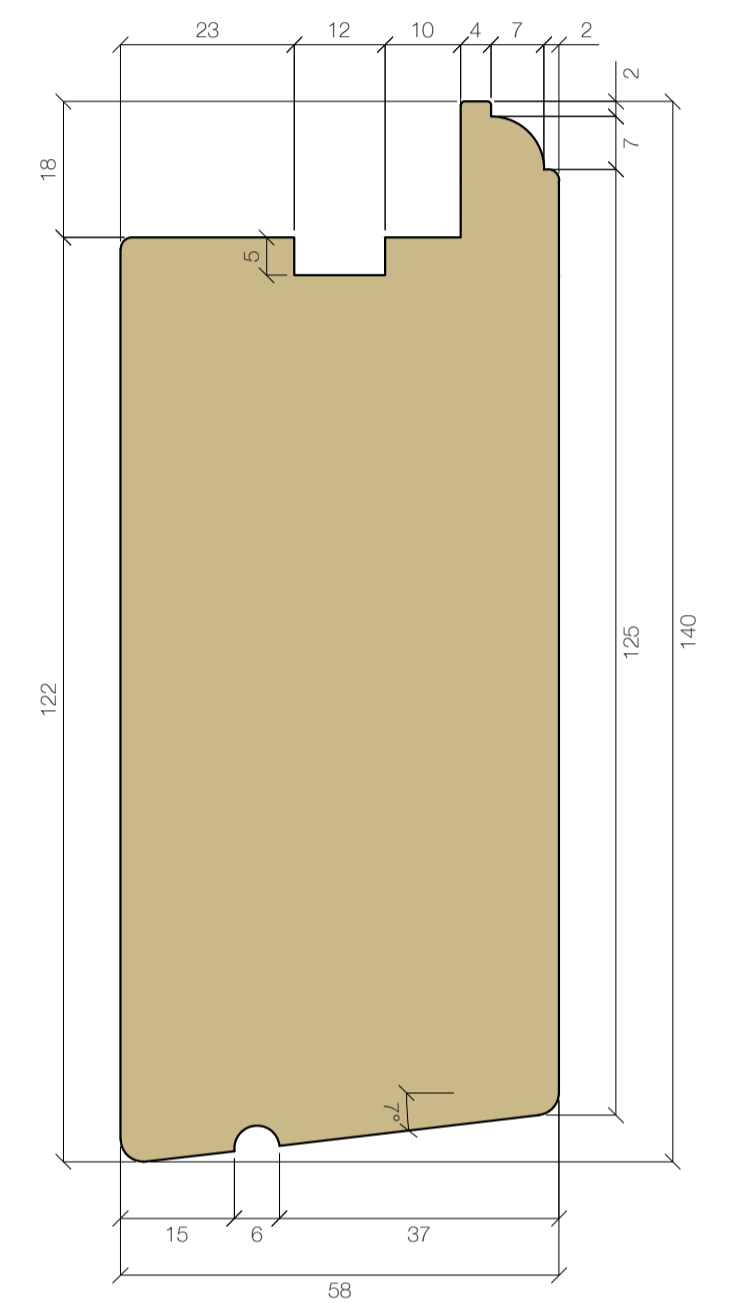

BASE RAIL
58x140 FINISH SIZE

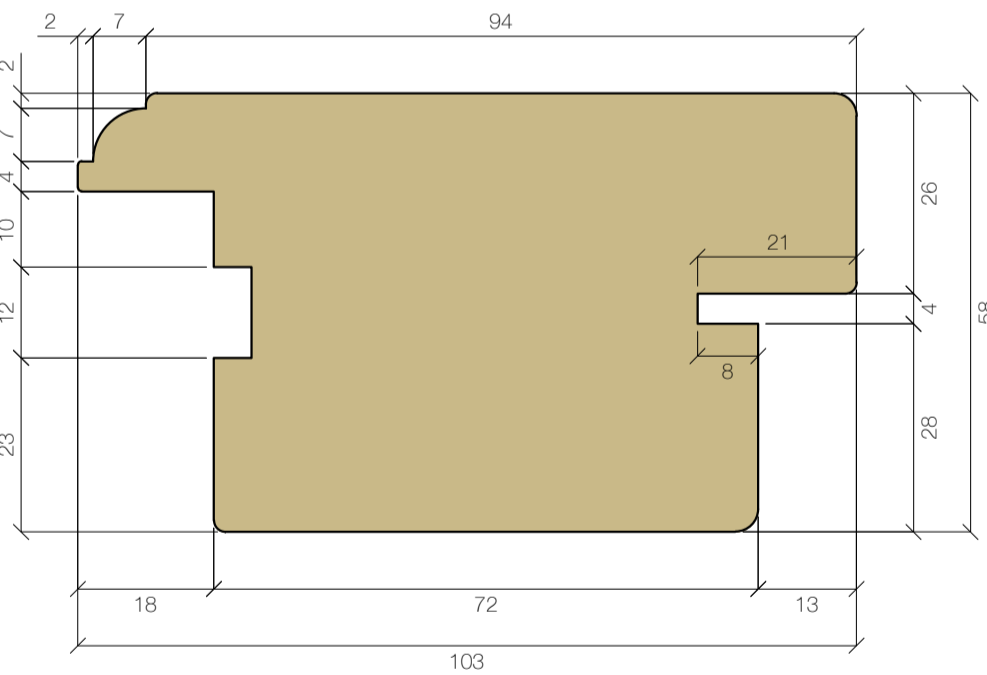

MEETING STILE (SLAVE)
58x103 FINISH SIZE

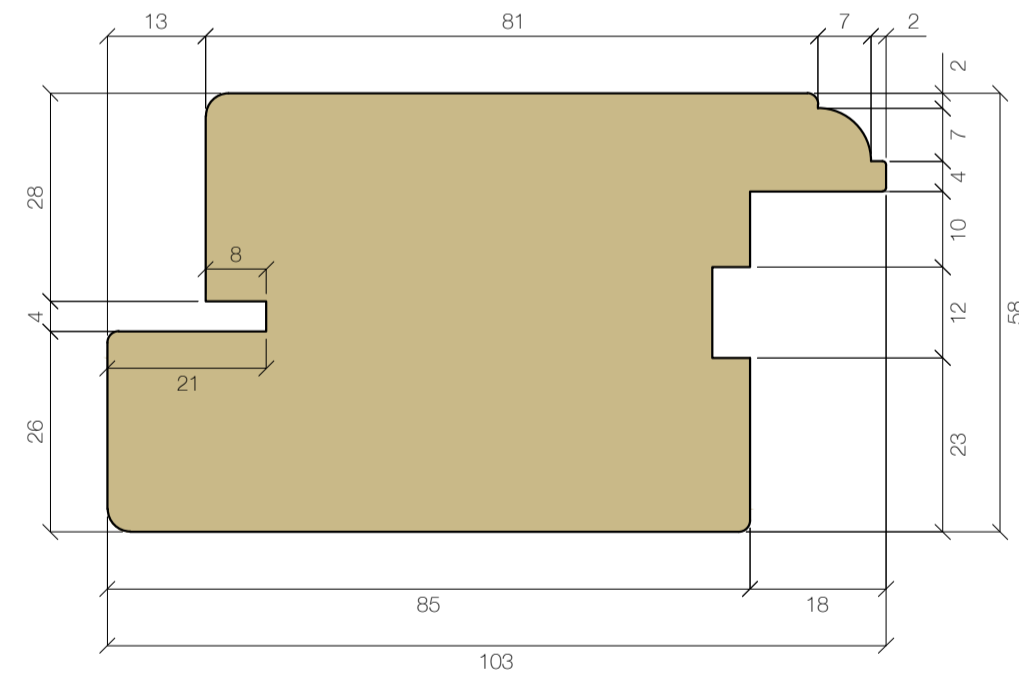

MEETING STILE (MASTER)
58x103 FINISH SIZE

FRAME

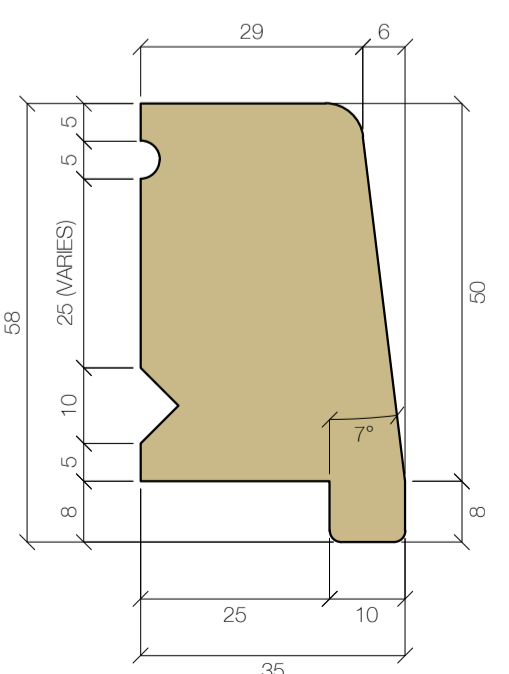

NOSING
58x35 (TYPICAL) FINISH SIZE

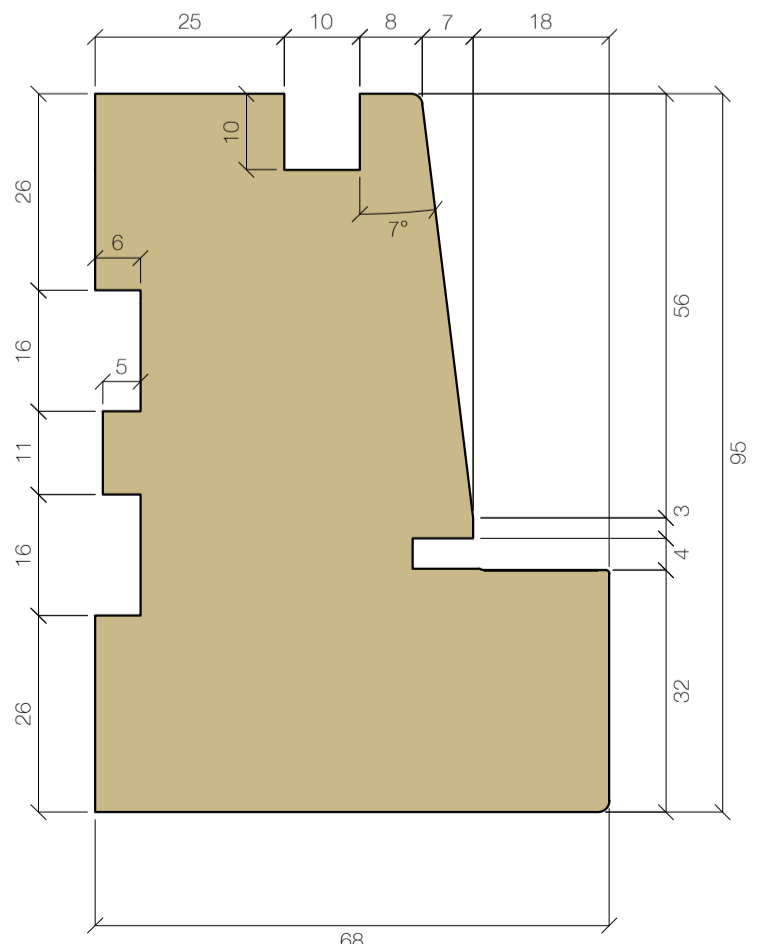

CILL
95x68 FINISH SIZE

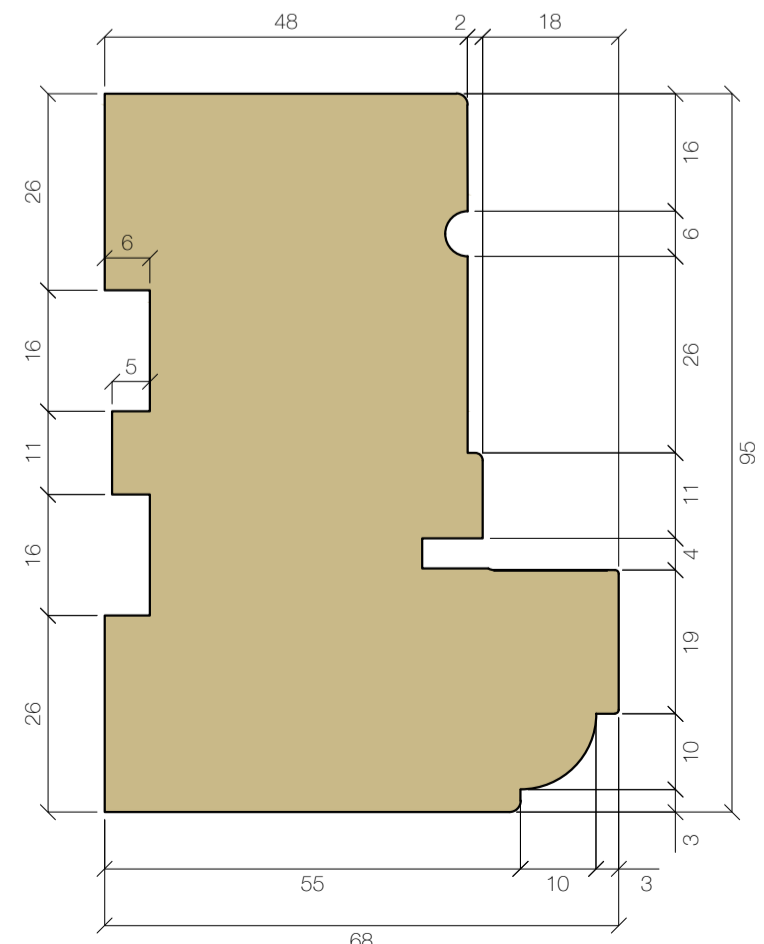

HEAD/JAMB
95x68 FINISH SIZE

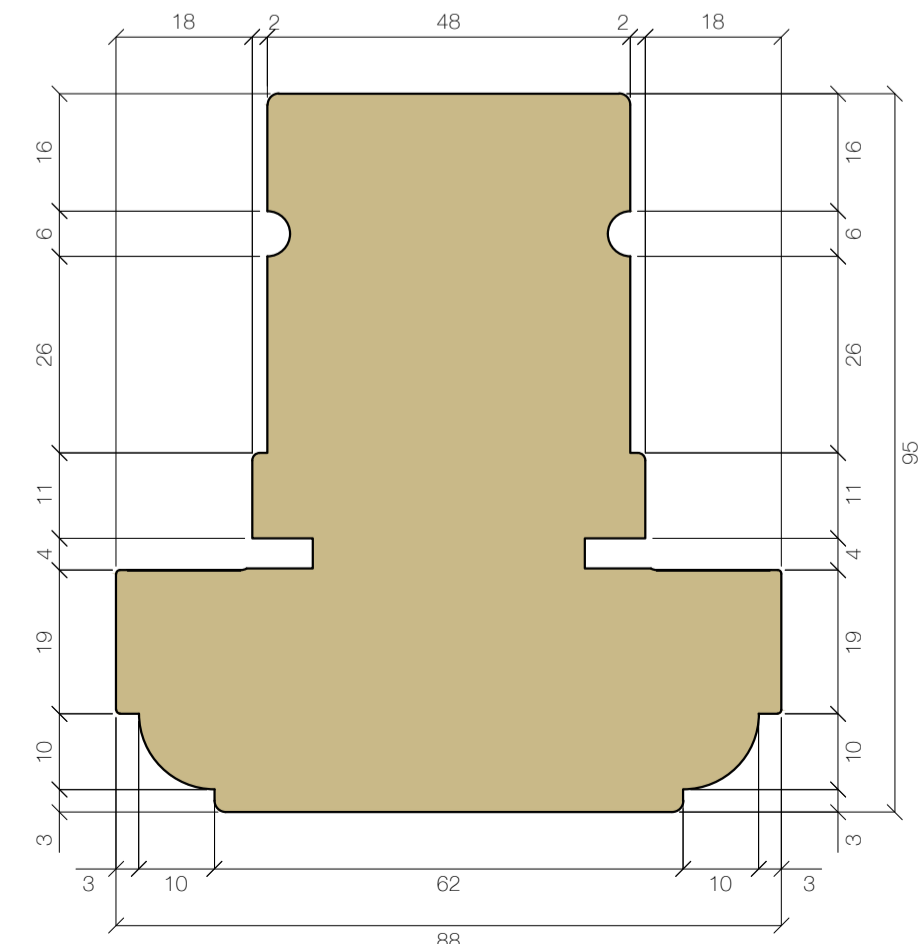

MULLION
95x88 FINISH SIZE

SECTION 1:2

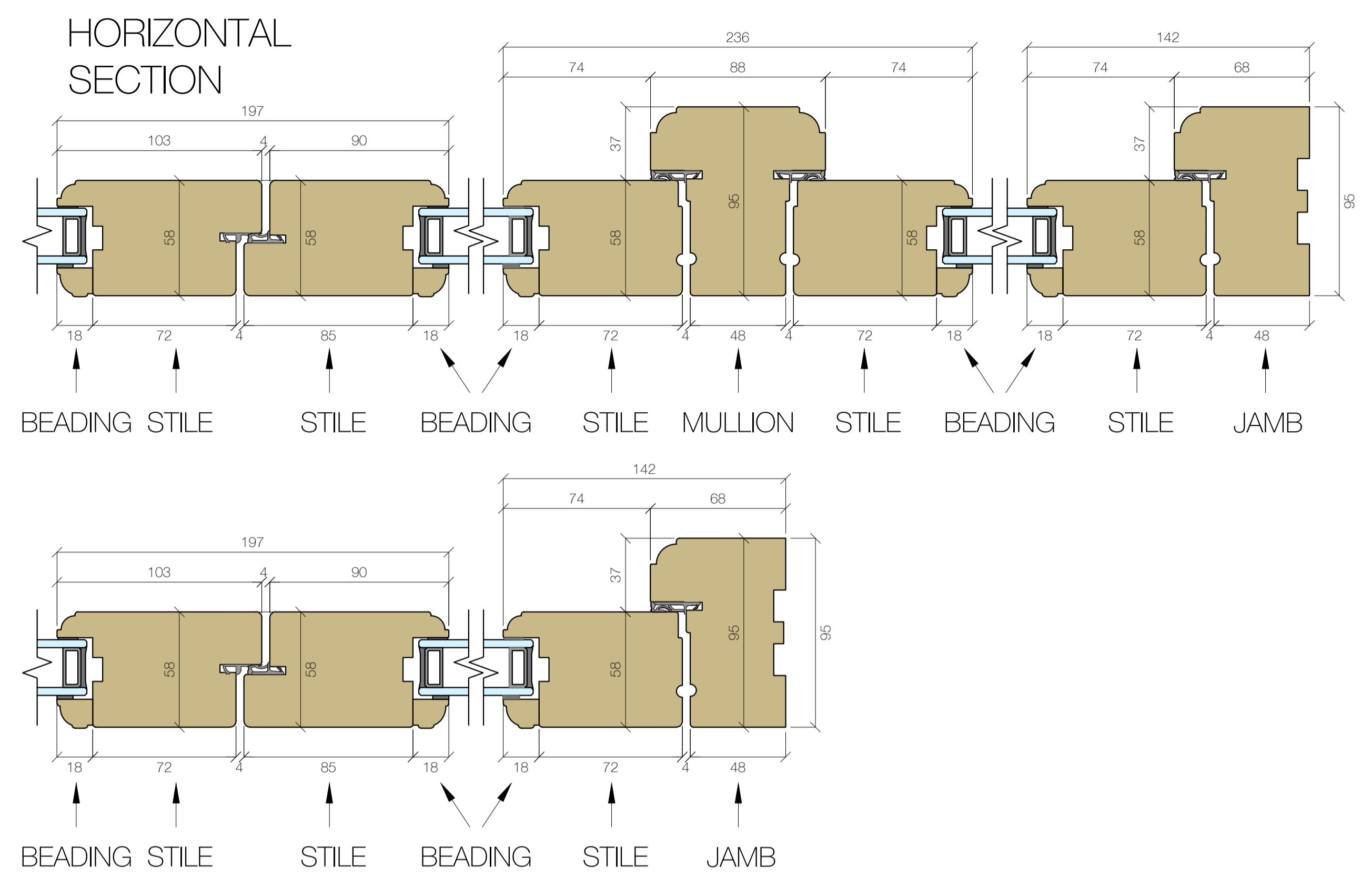

IF IN DOUBT - ASK!

NOTES:

DO NOT SCALE FROM DRAWINGS EXCEPT FOR PLANNING PURPOSES.

DUE TO OAK'S NATURAL IRON CONTENT, AN INITIAL STAINING WILL OCCUR TO STAGOLESTONES, BRICKWORK AND CONCRETE. THIS WILL DISAPPEAR NATURALLY IN TIME.

CONCRETE SLAB TO BE EXTENDED 50mm BEYOND INDEPENDENT POSTS TO ALLOW FOR PADSTONE SPLAY.

© THIS DRAWING IS THE COPYRIGHT OF PRIME OAK BUILDINGS LTD & MUST NOT BE REPRODUCED IN PART OR WHOLE WITHOUT CONSENT.

ANY DISCREPANCIES IN THIS DRAWING TO BE REPORTED PRIME OAK BUILDINGS LTD.

Weatherboard 170mm Gauge	N/A
Battens	N/A
Subdeck	N/A
Spandrel	N/A

WIDTH: 0.0m
DEPTH: 0.0m
LEAVES HEIGHT: 0.0m
ROOF PITCH: 0°
CANTILE: 0°
OUTSHOT: 0°

KEY:

- TIE BRACE
- SMALL TIE BRACE
- KNEE BRACE
- STUD BRACE
- SOLEPLATE / STUDWORK
- POSTS ON STAGOLESTONES
- POSTS ON SLAB/FIL BRICKWORK
- POSTS ON SOLEPLATE
- POSTS ON BRICKWORK

CLIENT: STANDARD DETAILS
JOB No.: FRENCH DOORS
SCALE: AS INDICATED @ A1
DATE: 21/06/2017
DRAWN BY: Sam Tyler
DRAWING No.: FPO_FD
REVISION No.: #
REVISION NOTES:

PRIME OAK
TURNING IDEAS INTO REALITY

Whitehouse Farm
Whitehouse Lane
Swindon
South Staffordshire
DY3 4PE

Tel:01384 296611
Fax:01384 273118

www.primeoak.co.uk