

STEEL FRAMED WINDOWS IN GREY SARNAFIL CLAD DORMERS IN SLATE ROOF AT 7th, 8th and 9th FLOOR.

EXISTING ALUMINIUM FRAMED CONSERVATORIES ON 6th FLOOR TERRACE.

STEEL FRAMED WINDOWS IN BRICK FACADE FROM 6th FLOOR DOWN TO 1st.

SOUTH STREET ELEVATION
SCALE 1:100

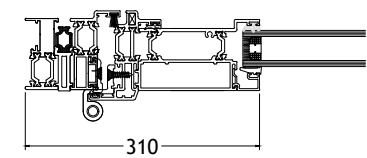

Detail A

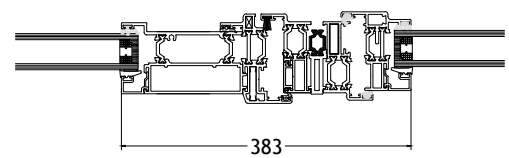

Detail B

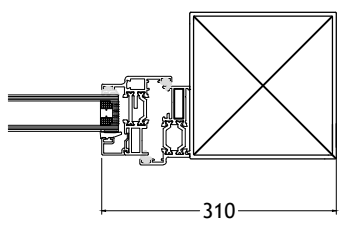

Detail C

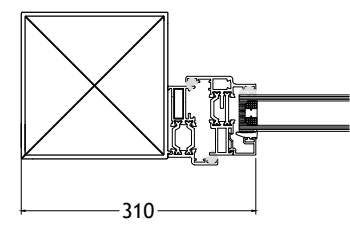

Detail D

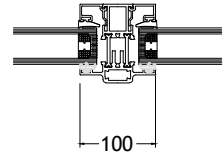

Detail E

FOR DETAILS SEE DIMENSIONS

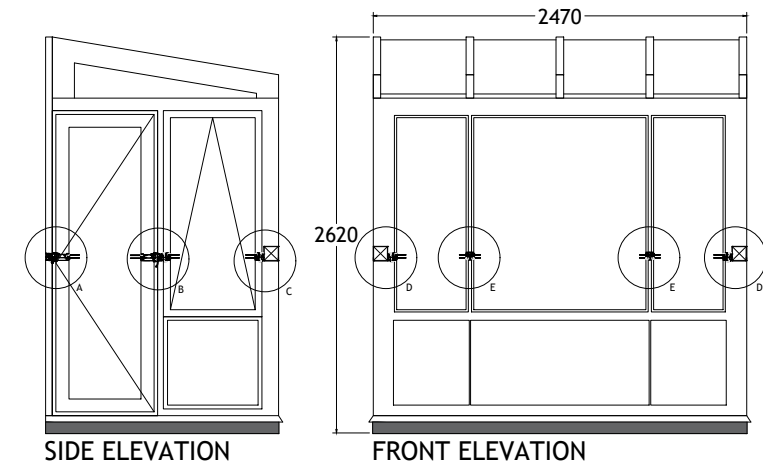

SIDE ELEVATION

FRONT ELEVATION

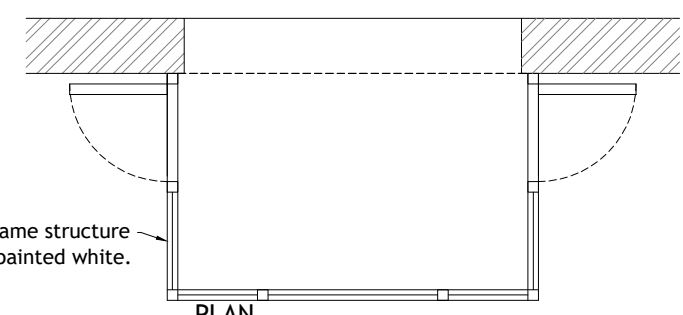

PLAN

