

TATA STEEL



Trisomet® 333 System

External roof and wall panel system



A global brand

Tata Steel, formerly known as Corus, is one of Europe's largest steel producers. We serve many different and demanding markets worldwide, including aerospace, automotive, construction, energy and power, and packaging. Our primary steelmaking operations in the UK and the Netherlands are supported by a global sales and distribution network.

Innovation and continuous improvement are at the heart of our performance culture. We aim to create value by offering a sustainable and value-added steel product range supported by unrivalled customer service. By working in partnership with you, we find the best solutions to meet your needs and help your business to perform.

Our European operations are a subsidiary of Tata Steel Group, one of the world's top ten steel producers. With a combined presence in nearly 50 countries, the Tata Steel Group including the Europe operations, Tata Steel Thailand and NatSteel Asia, has approximately 80,000 employees across five continents and an aggregate crude steel production capacity of over 28 million tonnes.

Tata Group

Tata Steel is part of the Tata Group, a diversified global company with operations in every major world market. The Tata Group of Companies has business operations in seven defined sectors – Materials, Engineering, Information Technology and Communications, Energy, Services, Consumer Products and Chemicals.

In the past ten years the Group has expanded internationally and now owns major brands such as Tetley, Jaguar and Land Rover. Tata Steel, with its acquisition of Corus in 2007, has secured a place among the top ten steel manufacturers in the world and it is the Tata Group's flagship Company.

Sustainability

Steel is an essential material, intrinsic to our way of life and to the products society will demand in a sustainable future. Steel is a material that is used, not consumed. It is recycled and used again, without any loss of quality, time after time. At Tata Steel, we are committed to making the products society needs and to making them in the most responsible way possible.

This means, practically, that we commit to:

- Producing steel products for the future
- Investing in sustainable steel-making
- Improving our existing processes
- Facilitating the recycling loop

Our steel enables our customers to make safer cars, more energy-efficient buildings and infrastructure, easily-recoverable and recyclable packaging and many other products which help to move society towards our vision of a sustainable future.

Building Envelope Sector

Tata Steel has extensive panel and profiling manufacturing capabilities. We are the only company able to offer a comprehensive range of insulated panels, built-up systems, facades, structural roof and floor decking profiles from one single UK source, with the support and backing of a truly global company and complete supply chain.

With such a diverse product portfolio and over 40 years experience, we are uniquely able to offer the specifier an unbiased solution to meet the design criteria for any project.

Offering unrivalled technical support, practical guidance, performance and quality you would expect from one of the industry's most trusted brands enables our customers to exceed their clients' requirements over the long term.



Client: Unite
Architect: Studio 1 Architects
Main contractor: Watkin Jones and Sons Limited
Cladding system: Trisomet® 333 System
Colorcoat® product: Colorcoat Verso®
in Merlin Grey

Platinum® System Guarantee

The Platinum® System Guarantee offered by Tata Steel provides peace of mind to clients for up to 25 years. The guarantee is free of charge and covers material performance and workmanship.

The guarantee covers all of the components used in the construction of the building envelope solutions provided by Tata Steel making it the most comprehensive system guarantee offered on the market.

Tata Steel are in a position to provide this reassurance due to our innovative supply chain partnerships with the third party component suppliers. All components including fixings, roof lights, fall arrest, gutters and walkways used in the system are covered under the guarantee.

The approved Platinum® suppliers are selected on the basis of their ability to meet the stringent technical criteria and performance set for each component and provide a component guarantee of up to 25 years.

Specifiers and contractors benefit from the guarantee with the freedom to choose from the list of approved suppliers.

As part of the Platinum® System Guarantee, approved Platinum® contractors undertake the installation of the projects. The workmanship of the Platinum® approved contractors is continually checked to ensure the systems are installed accurately and expertly without compromising performance. The workmanship of the installation is guaranteed for up to 12 years.

Tata Steel act as a one point of contact from the beginning of the project right through to the end of the duration of the guarantee period. The Platinum® System Guarantee provides the client with a direct link to Tata Steel in the unlikely event of a building failure.

In addition to the Platinum® System Guarantee, the Confidex® Guarantee, is available with Colorcoat HPS200 Ultra® and Colorcoat Prisma®. This offers the most comprehensive guarantee for pre-finished steel products in Europe and provides peace of mind for up to 40 years. Unlike other guarantees, Confidex® Guarantee covers cut edges for the entirety of the guarantee period and does not require annual inspections to maintain its validity.



Trisomet® 333 System overview

The Trisomet® 333 System from Tata Steel is an insulated roof and wall panel system comprising of a straightforward side lapping detail allowing faster installation and a wider spaced trapezoidal steel external skin, providing optimum performance for water drainage, strength and walkability. Its auto-hesively bonded polyisocyanurate (PIR) insulation core uses the latest foam technology providing enhanced environmental benefits, together with fire performance approved by LPCB.

Trisomet® 333 System is a robust, one component, factory controlled, made to measure, insulated roof and wall panel system that provides time savings in completion of cladding programmes; eliminates the risk of interstitial condensation; and ensures uniform thermal performance throughout the building envelope. Suitable for roof pitches down to 4 degrees.

The system offers excellent economic and environmental performance, and comes with comprehensive certification and the Tata Steel Platinum® System Guarantee.

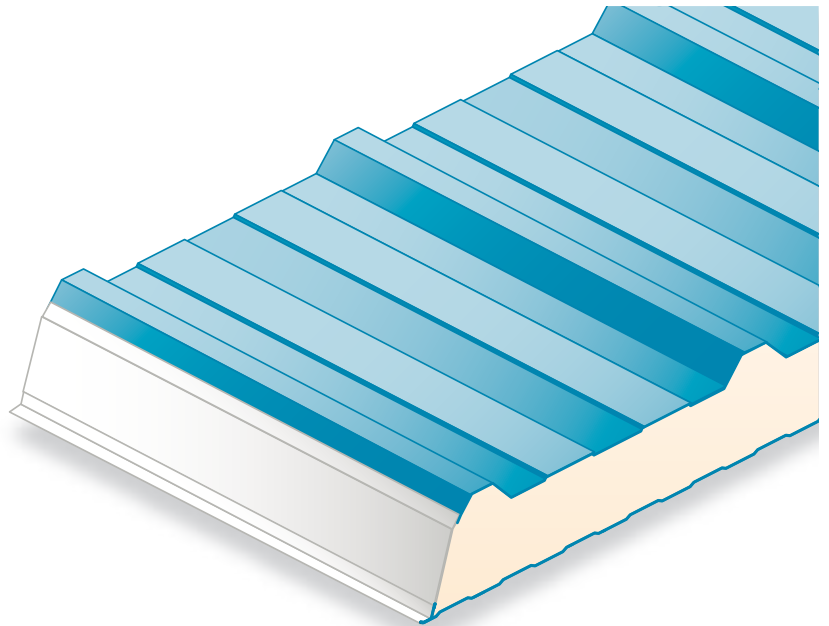



Case study

Ysgol Cae Top School

Trisomet® 333 System for the roof and Trimapanel® System for the wall have been specially selected to feature on the new state of the art school in the Eithinog area of Bangor.

This much anticipated £4 million investment by Gwynedd Council will ensure the latest modern 21st century facilities for the pupils and staff of the primary school which will be located near the secondary school, Ysgol Friars in the city. More information can be found on page 50.

Client: Development Directorate – School Services

Architect: Gareth Jones – ISP Architects LLP

Main contractor: Carillion Building

Installing contractor: Lester Fabrications

Cladding system: Trisomet® 333 System

Colorcoat® product: Colorcoat Verso® in Merlin Grey

Key benefits: Trisomet® 333 System

The one fix construction provides fast and consistent installation, resulting in the contractor spending less time on site.

The panel is fully filled with closed cell foam eliminating the risk of interstitial condensation and providing a consistent insulation performance over the building envelope.

Trisomet® 333 System is manufactured in factory conditions operating to BS EN ISO 9001:2008.

Panel lengths up to 20m are available to optimise speed of installation and minimise waste.

LPCB (Loss Prevention Certification Board) approval to LPS 1181 part 1 helps reduce insurance premiums and assures reaction to fire performance.

Fire resistance performance of 25mins insulation and 4 hours integrity achievable with standard fixing and sealing methods.

The Trisomet® 333 System is a sustainable solution with responsible sourcing and traceability of all component materials. All steel elements are produced within the UK through Tata Steel's steel production, strip processing, galvanising, coating and profiling facilities.

The state of the art PIR core has zero ozone depletion potential (ODP) and a very low global warming potential (GWP) of less than 5.

Colorcoat® pre-finished steel products are used as standard on the Trisomet® 333 System offering long term performance with the Confidex® Guarantee providing peace of mind for up to 40 years.

The system's carbon footprint is minimised by the manufacturing process being situated adjacent to the Colorcoat® and galvanising lines used to manufacture the pre-finished steel.

Confidex Sustain®, which offers a CarbonNeutral® solution for the building envelope is available with the Trisomet® 333 system when using Colorcoat HPS200 Ultra® or Colorcoat Prisma® pre-finished steel.

Platinum® System Guarantee offers a 25 year free material performance cover, including up to a 12 year workmanship guarantee.

System performance data

Trisomet® 333 System

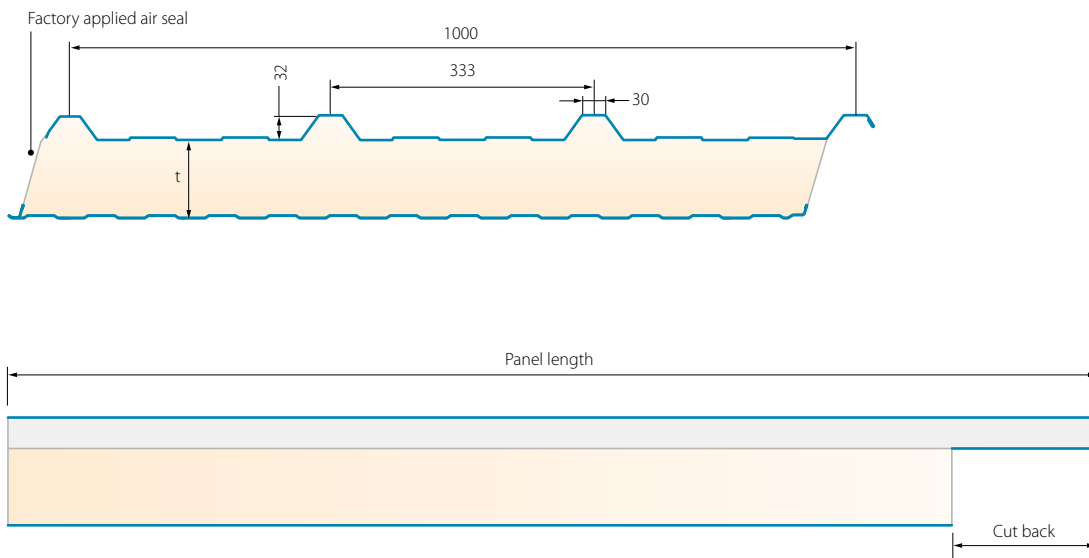

General panel information

Thickness, t (mm)	40, 60, 80, 100 and 120
Maximum length (mm)*	20,000
Minimum length (mm)	
On-line	1,800
Off-line (subject to extra charge)	300
Cutback (mm)**	
Minimum	25
Maximum	250**
Weight (based on thickness mm) (kg/m ²)	
40	9.86
60	10.62
80	11.00
100	11.80
120	12.60

* The panel length is measured by the length of the external sheet, as shown above.

** Panels will always have one flush end and one cutback end; therefore, they will be handed and should be ordered according to the direction of lay required.

*** Recommended end laps are 50mm for horizontal, 100mm for vertical and 150mm for roof applications.

Panel manufacturing tolerance

Cover width (mm)	±2
Thickness (mm)	±2
Squareness (mm)	<6
Cutback (mm)	-2 +5
Length (mm) < 3m	±5
Length (mm) > 3m	±10

Tolerance is in accordance with BS EN 14509.

General reference

All measurements throughout this brochure are referenced in mm unless stated otherwise. Technical illustrations are not to scale.

Span/load tables

The Span Tables below have been created in accordance with BS EN 14509 and calculated by the Steel Construction Institute (SCI). The values are based on a 0.5mm external face, 0.4mm internal liner and a 1.6mm minimum purlin thickness to a maximum permitted wall cladding deflection of Span/200 under imposed load.



Safe imposed (positive) loads (kN/m²)

Span condition	Core thickness (mm)	Span (m)												
		1.2	1.4	1.6	1.8	2.0	2.2	2.4	2.6	2.8	3.0	3.2	3.4	3.6
Single	40	3.35	2.78	2.36	2.03	1.77	1.55	1.37	1.14	0.93	0.75	0.62	0.50	0.41
	60	4.25	3.63	3.17	2.79	2.48	2.22	1.99	1.75	1.50	1.30	1.12	0.98	0.83
	80	5.14	4.49	3.98	3.56	3.20	2.89	2.62	2.38	2.08	1.82	1.60	1.41	1.25
	100	6.04	5.35	4.79	4.33	3.93	3.58	3.26	2.98	2.68	2.37	2.10	1.87	1.67
	120	6.93	6.20	5.61	5.11	4.66	4.26	3.91	3.59	3.28	2.92	2.61	2.34	2.11
Double	40	3.07	2.36	1.86	1.51	1.26	1.07	0.93	1.14	0.93	0.75	0.62	0.50	0.41
	60	3.50	2.72	2.17	1.81	1.52	1.31	1.13	0.99	0.89	0.79	0.71	0.65	0.59
	80	3.81	2.98	2.39	1.97	1.66	1.42	1.25	1.11	0.99	0.91	0.83	0.77	0.70
	100	3.93	3.14	2.53	2.07	1.72	1.48	1.29	1.14	1.03	0.93	0.85	0.79	0.73
	120	4.09	3.37	2.75	2.24	1.85	1.56	1.35	1.19	1.06	0.97	0.88	0.81	0.75
Multi	40	2.79	2.10	1.66	1.36	1.13	0.96	0.82	0.72	0.64	0.57	0.51	0.46	0.41
	60	3.06	2.33	1.87	1.54	1.30	1.11	0.97	0.86	0.77	0.69	0.63	0.57	0.53
	80	3.28	2.50	1.99	1.65	1.40	1.21	1.06	0.94	0.84	0.77	0.71	0.66	0.61
	100	3.36	2.57	2.04	1.66	1.41	1.22	1.07	0.95	0.86	0.77	0.70	0.66	0.61
	120	3.43	2.66	2.10	1.71	1.42	1.22	1.07	0.95	0.85	0.77	0.70	0.63	0.59

Safe imposed (negative) loads (kN/m²)

Span condition	Core thickness (mm)	Span (m)												
		1.2	1.4	1.6	1.8	2.0	2.2	2.4	2.6	2.8	3.0	3.2	3.4	3.6
Single	40	3.50	2.93	2.51	2.19	1.92	1.70	1.52	1.36	1.19	1.04	0.91	0.81	0.72
	60	4.41	3.80	3.33	2.96	2.65	2.38	2.15	1.83	1.57	1.37	1.20	1.07	0.95
	80	5.32	4.67	4.16	3.74	3.38	3.07	2.69	2.28	1.96	1.71	1.50	1.33	1.19
	100	6.22	5.53	4.98	4.52	4.12	3.77	3.23	2.74	2.36	2.05	1.81	1.60	1.43
	120	7.13	6.40	5.81	5.31	4.86	4.47	3.77	3.20	2.76	2.40	2.11	1.87	1.68
Double	40	3.05	2.40	1.92	1.59	1.35	1.17	1.04	0.93	0.84	0.76	0.70	0.65	0.60
	60	3.05	2.63	2.24	1.88	1.61	1.41	1.24	1.11	1.01	0.93	0.85	0.80	0.74
	80	3.06	2.63	2.31	2.06	1.78	1.56	1.39	1.26	1.14	1.07	1.00	0.93	0.88
	100	3.06	2.64	2.32	2.07	1.87	1.64	1.46	1.32	1.21	1.12	1.04	0.98	0.93
	120	3.07	2.64	2.32	2.07	1.88	1.71	1.53	1.38	1.25	1.16	1.08	1.01	0.96
Multi	40	2.81	2.14	1.72	1.43	1.22	1.06	0.94	0.84	0.76	0.70	0.65	0.60	0.56
	60	3.05	2.40	1.95	1.64	1.40	1.22	1.09	0.98	0.90	0.83	0.77	0.72	0.68
	80	3.06	2.62	2.12	1.78	1.53	1.35	1.21	1.09	1.00	0.94	0.88	0.83	0.78
	100	3.06	2.64	2.20	1.83	1.58	1.39	1.25	1.13	1.04	0.96	0.90	0.85	0.81
	120	3.07	2.64	2.28	1.89	1.61	1.41	1.27	1.15	1.05	0.98	0.91	0.85	0.81

If safe loading shown above is not satisfactory to your requirements, it is possible to adjust performance by using alternative fastener layouts, purlin specifications and/or deflection limits. For further information please contact the Technical Department 0845 30 88 330.

Performance benefits



Thermal performance

The Trisomet® 333 System complies with the minimum requirements of the conservation of fuel and power sections of the Building Regulations for England and Wales (Part L2) and Scotland (Technical Handbook Section 6 Energy). The panel construction offers highly consistent insulation performance, and the site-formed junctions provide a practical and effective method of ensuring good thermal performance.

Thickness (mm)	U-value (W/m²K)*	Typical application
40	0.46	Unheated building
60	0.33	Min Part L requirement for wall
80	0.25	Min Part L requirement for roof
100	0.20	Enhanced
120	0.16	Enhanced

* Figures computer modelled in accordance with EN ISO 10211 as stated in MCRMA Technical Note 14.



Fire safety

The Trisomet® 333 System carries Grade EXT-B and EXT-A approval by the LPCB. Fire resistance performance of 25 mins insulation and 4 hours integrity is also achievable with standard fixing and sealing methods for panels 60mm and above. The panel achieves a Grade AA rating in accordance with BS 476-3, which tests for external surface spread of flame and fire penetration (AA is the best result achievable). The internal surface of the panel complies with Class 'O' in accordance with the Building regulations when tested to BS 476 parts 6 & 7 and also achieves a Class B s2 rating in accordance with EN 13501-1.



Acoustic performance

The acoustic performance of the Trisomet® 333 System has been predicted using software developed by the Department of Applied Acoustics, University of Salford, under a research contract funded by the Metal Cladding and Roofing Manufacturers Association (MCRMA). The results in the table are based on an 80mm core.

Frequency (Hz)	SRI Values (dB)*	Frequency (Hz)	SRI Values (dB)*
100	12.1	800	27.2
125	13.6	1,000	28.9
160	15.3	1,250	30.6
200	16.9	1,600	32.5
250	18.5	2,000	34.3
315	20.2	2,500	36
400	21.9	3,150	35.9
500	23.6	4,000	33.8
630	25.4	5,000	31.2

Weighted S.R.I RW = 28.5dB

* The predicted sound reduction index values should only be used to provide guidance for preliminary design and/or appraisal of cladding systems.



Water penetration

In accordance with product standard BS EN 14509, the water tightness of a system should be tested to EN 12865. The standard advises that system should achieve water tightness to a pressure of 600 Pa for normal conditions. Laboratory testing shows evidence that the Trisomet® 333 System is watertight up to a pressure of 1050 Pa, which far surpasses this requirement.



Air tightness

The cladding panel and its junction details must be airtight so that the air permeability of the building does not exceed 10m³/h/m² at an applied pressure of 50 Pa, in accordance with the Building Regulations for England and Wales (Part L2) and Scotland (Technical Handbook Section 6 Energy). In laboratory tests in accordance with EN BS 12114, the sealed panel show evidence of air leakage as low as 0.43m³/h/m².

A practical expectation for a finished building, with effective sealing at all junctions would be 3-5m³/h/m². However enhanced detailing practises on large shed buildings can realise air leakage performance figures of less than 3m³/h/m².



Environmental credentials

The Trisomet® 333 System is a sustainable solution with responsible sourcing and traceability of all component materials. All steel elements are produced within the UK Tata Steel's steel production, strip processing, galvanising, coating and profiling facilities. In addition the system's carbon footprint is further minimised by the manufacturing process being situated adjacent to Colorcoat® pre-finished steel production facility.

The PIR insulation within the system has zero ozone depletion potential (ODP) and a very low global warming potential (GWP) of less than 5. Both these factors support the achievement of a high BREEAM rating.

All steel elements are 100% recyclable back into new steel products, without loss of quality. The insulation can be separated using existing scrap shredding technology, after which the materials can be recovered or recycled.



Platinum® System Guarantee

The Trisomet® 333 System is available with the Platinum® System Guarantee. As long as the panels are supplied to an approved specification and fitted by Platinum® System Guarantee approved installers, the system is eligible for a 25 year component guarantee and up to 12 years workmanship guarantee.

Summary of Building Regulation requirements



The Building Regulations for the Conservation of Fuel and Power in England, Wales and Scotland have recently been revised. These regulations present a major step change in how the energy use of buildings is determined as the Government moves towards their aspiration for zero carbon buildings.

Part L covers the building regulations in England and Wales and in Scotland, this is covered by the Technical Handbook, Section 6 – Energy.

The regulations distinguish between new build and existing properties, as well as between dwellings and non-domestic buildings. Part L is divided into four sections: L1A 'New Dwellings', L1B 'Existing Dwellings', L2A 'New Buildings other than dwellings' and L2B 'Existing Buildings other than dwellings'. The main area of interest for Metal Cladding Systems is the non-domestic sector and a brief summary of the changes to these building regulations is provided below.

Part ADL2 – New non-domestic buildings in England & Wales

A fundamental change in Part L 2010 for non-domestic buildings is in the target-setting process. The new process recognises that it is easier and more cost effective to make improvements in some building types than in others. The aim for a 25% reduction in CO₂ emissions from new non-domestic buildings is achieved on aggregate across the new-build stock rather than for each individual building. Some building types will be required to achieve a bigger improvement than 25%, whilst others will need to achieve less.

The Target Emission Rate (TER) will still be generated through the National Calculation Methodology (NCM) using SBEM, but is no longer based on a 2002 notional building; instead the TER is based on a 2010 notional building aligned with the aggregate approach.

The Building Regulations will now require the TER and Design Emission Rates (DER) calculations to be submitted to Building Control at the design stage as well as at completion.

The notional building will either have 40% vertical glazing, 12% roof lights or no glazing at all, with the allocation being driven by the planning-use class. The limiting U-values for non-domestic buildings have not changed; these are shown below along side the figures used within the 2010 notational building.

Element	AD-L2A 2010 back stop value	2010 notional building value
Roofs U-value (integral insulation)	0.25	0.18
Walls U-value	0.35	0.26
Floors U-value	0.25	0.22
Roof lights	Max 20% area	12% area
U-value	2.2	1.80
Building Air Permeability	10.0	5.0

The notational building also uses improved efficiencies for lighting and heating services, which will be essential for compliance. This notional 'blueprint' is a good start for design, however, there is scope for design flexibility, and our technical engineers are on hand to advise on the effects of changes to any element.

A revised procedure is now in place to limit the effects of solar gain, whether or not a building has air conditioning at the time of design. This is a separate calculation to that of the TER but will need to be proven to Building Control as part of the submission.

Scotland – Non-domestic Handbook, Section 6 – Energy

The Scottish approach is basically the same approach as we are currently using; i.e. a 2002 notional building with a percentage improvement (in Part L this is called the flat approach).

However the backstop values have been improved, and the percentage improvement over 2006 levels is a flat 30% (this equates to approximately 50% improvement over the 2002 notational building). This is likely to mean greater emphasis on improvements to all areas, especially on hotels, offices and commercial type buildings.

The following tables include the standard package of construction performance measures for the notional building and backstop values:

Element	AD-L2A 2010 back stop value	2002 notional building value
Roofs U-value (integral insulation)	0.20	0.25
Walls U-value	0.27	0.30
Floors U-value	0.22	0.25
Roof lights U-value	2.0	2.2

No backstop value is set for air permeability. However, it is recommended that buildings be designed to achieve a value of 10m³/h/m² @ 50 Pa or better.

Trisomet® 333 System manufacturing facility

The Trisomet® 333 System is manufactured on the panel production line at the Tata Steel site in Shotton, North Wales. The state-of-the-art insulated panel production line, which is almost 300 metres long, is one of the most automated and efficient in Europe in terms of manning, yield loss, energy use and volume output.

The £6 million investment by Tata Steel demonstrates commitment to innovation and sustainability through investment in the new facility. In order to reduce the environmental impact and carbon footprint of its processes Tata Steel has paid attention to its supply chain of raw materials.

Steel production and coil strip processing take place in Port Talbot, South Wales, and uncoated coil is then transferred to Shotton, North Wales via rail, providing short and efficient transfer, within the UK.

The Colorcoat® lines produce a range of Colorcoat® pre-finished steel products at the Shotton site.

The panel line is positioned adjacent to the Colorcoat® line consequently incurring no material transport costs and further reducing CO₂ emissions.

The panel line is capable of working off 20 tonne Colorcoat® coils this results in minimising steel waste, reducing coil changes and reducing the likelihood of damage.

The panel line has the longest double belt (48 metres) in Europe enabling the line to run quicker while maintaining the required foam curing period. The Shotton site uses waste steam generated in the Colorcoat® line to heat the double belt thereby being very prudent with energy consumption and environmentally friendly.

Product quality is paramount at Tata Steel and continuous electronic/laser monitoring of dimensions and shape ensure consistent and accurate product quality. Panels of up to 20 metres long are available as standard to optimise speed of installation and minimise waste. The panels come in a choice of thicknesses.

Automated processes are in place for the stacking, wrapping and packaging of the Trisomet® 333 System.

Fully automated machines stack, de-stack, overlap, tape, saw and package to ensure the panels are ready to safely transport to the customer. Sustainable packaging has been used and is easily recyclable. Pallets are reclaimed and re-used by Tata Steel.



Trisomet® 333 System approvals

The Trisomet® 333 System has been independently assessed and carries approvals and certification as shown below.



LPCB stands for Loss Prevention Certification Board and is a certification brand of BRE Global Limited. The approval is listed in the 'Red Book' which is a world renowned listing of independently certified products, and is the essential reference for those responsible for the design, specification and purchase of fire and security products.



The system has been tested and assessed for fire performance by Warrington Fire, who are the largest independent fire testing, consultancy, research and certification organisation in the UK.



'SCI Assessed' quality mark. This mark testifies that the Steel Construction Institute (SCI) has independently verified the systems' technical data.



British Board of Agrément Certificate for its Colorcoat® pre-finished steel. The Agrément Certificate is recognised by specifiers and other industry decision-makers as proof that the products covered by them have been rigorously assessed, will allow compliance with building regulations to be achieved and will last for a defined period.



Award winning Confidex Sustain® offers the world's first CarbonNeutral® building envelope, measuring and offsetting its impact from cradle to cradle. This means for every 1kg of unavoidable CO₂ emitted by the system, Tata Steel will offset 1kg in climate friendly projects overseas.



The BREEAM assessment method is designed to help construction professionals understand and mitigate the environmental impacts of the developments they design and build. The Trisomet® 333 System helps provide a number of points that contribute significantly to a high BREEAM rating.

Colorcoat® products and services

Colorcoat® products are supplied through Tata Steel, the market leading systems manufacturer of both, built-up and insulated panel systems, who provide the very highest quality and service.

Colorcoat® Supply Chain Partner

Due to this unique integrated supply chain Tata Steel are able to provide consistency in the quality of material used and they are able to ensure a lower carbon footprint as the supply chain is entirely UK based. With the added benefit that the Trisomet® 333 System is processed directly adjacent to the Colorcoat® lines used to manufacture the pre-finished steel.

Colorcoat® products and services

The Colorcoat® brand provides the recognised mark of quality and metal envelope expertise exclusively from Tata Steel (formerly Corus). For nearly 50 years Tata Steel has developed a range of technically leading Colorcoat® pre-finished steel products which have been comprehensively tested and manufactured to the highest quality standards. Tata Steel supply pre-finished steel to normal and special tolerances according to EN 10143:2006 to ensure that the cladding performs as designed.

Our Colorcoat® products are supported by a range of services such as comprehensive guarantees, colour consultancy and technical support and guidance.

To ensure the long-term performance and appearance of the building, it is important that the pre-finished steel product is specified alongside the cladding system. To secure the peace of mind that comes from a rigorously manufactured and tested product from Tata Steel, ensure Colorcoat® as well as the individual product name is specified for your cladding system e.g. Tata Steel Colorcoat HPS200 Ultra®.

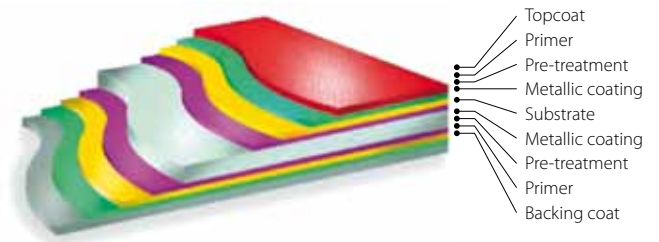
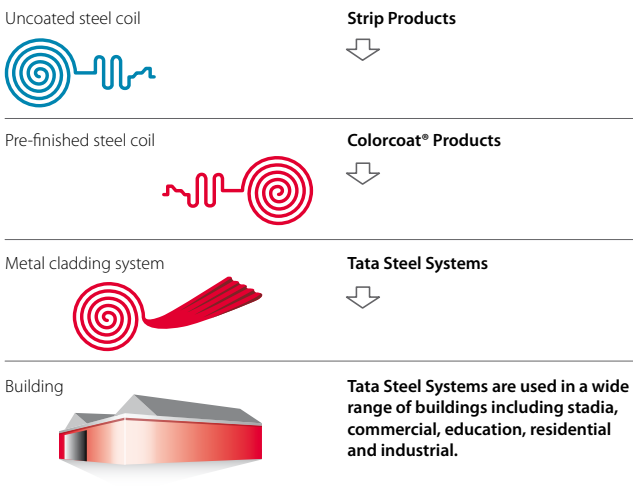

Client: Barton Business Park Ltd
Architect: Stephen George Partners
Cladding system: Trisomet® 333 System
Colorcoat® product: Colorcoat HPS200 Ultra® in Goosewing Grey



Colorcoat HPS200 Ultra®

The latest generation product for roof and wall cladding, Colorcoat HPS200 Ultra® is the only pre-finished steel product to ensure your building envelope maintains its integrity and aesthetic appeal for up to 40 years, without ongoing maintenance or inspection costs. We guarantee it won't let you down. For more information visit www.colorcoat-online.com/ultra

Key benefits include:

- Confidex® Guarantee for up to 40 years including cut edges.
- 40 standard colours in solid and matt shades.
- Surpasses requirements of Ruv4 and RC5 as per EN 10169:2009 proving outstanding colour retention and corrosion resistance.
- Incorporates the most advanced coating technology, to provide twice the colour and gloss retention of standard plastisol products.
- Scintilla® embossed as a mark of authenticity from Tata Steel.
- Available CarbonNeutral® through Confidex Sustain®.

Colorcoat Prisma®

Designed to withstand the rigours of the external environment, versatile, lightweight and strong, Colorcoat Prisma® pre-finished steel is the ideal choice for your building envelope for long lasting colour. With a contemporary new colour range and an optically smooth finish, inspire your imagination. For more information visit www.colorcoat-online.com/prisma

Key benefits include:

- Confidex® Guarantee for up to 30 years including cut edges.
- 27 standard colours in solid, metallic and matt shades.
- All solid and metallic colours surpass requirements of Ruv4 and RC5 as per EN 10169:2009 proving outstanding colour retention and corrosion resistance.
- Reverse side branding making traceability easy, so you can rest assured that your building is protected with the highest quality from Tata Steel.
- Available CarbonNeutral® through Confidex Sustain®.

Colorcoat® LG

Leathergrain plastisol product suitable for roof and wall cladding applications where good performance is required at a competitive price. Available with a 25 year performance guarantee.

Colorcoat® services

Confidex® Guarantee

Offers the most comprehensive guarantee for pre-finished steel products in Europe and provides peace of mind for up to 40 years. Unlike other guarantees, Confidex® covers cut edges for the entirety of the guarantee period and does not require mandatory annual inspections. Registering the Confidex® Guarantee provides a direct link to Tata Steel. In the unlikely event of a coating failure, Tata Steel can be contacted directly and independently of the contractual supply chain. Not only does this save time and money but can also avoid unnecessary legal involvement and the associated costs. In the 'worst case' scenario elements of the contractual chain may no longer be in existence making a complaint difficult or even impossible to pursue without the direct link to Tata Steel.

Confidex Sustain®

Confidex Sustain® is an enhancement of the Confidex® Guarantee. As well as covering the performance of the Colorcoat HPS200 Ultra® and Colorcoat Prisma® used on your building, it offsets the unavoidable CO₂ emitted during production of the whole cladding system, including the insulation and fixings. For more information visit www.colorcoat-online.com/sustain

Repertoire® Colour Consultancy

The Repertoire® Colour Consultancy can advise on colours and colour strategies using a range of standard shades, as well as discussing individual bespoke colour requirements. For orders over 2,000m² Tata Steel can match almost any solid colour from physical swatches to commonly used references such as RAL, NCS and British Standard and more unusual standards. Available with Colorcoat HPS200 Ultra® and Colorcoat Prisma® and the Confidex® Guarantee. For more information visit www.colorcoat-online.com/repertoire

Colorcoat® Specification Wizard

H31/H43 NBS specifications for Colorcoat HPS200 Ultra® and Colorcoat Prisma® can be quickly produced using our Colorcoat® Specification Wizard. Colour, cladding system and Confidex Sustain® can all be specified in just a few clicks. Visit www.colorcoat-online.com/specwizard to produce your specification.

Colorcoat® Technical Papers

Tata Steel have published a wide range of technical papers to independently guide and advise you on key issues in building design and construction commonly considered for roof and wall cladding systems using Colorcoat® products. From acoustics and air-tightness to low carbon design, gauge tolerance and fire performance, there is a technical paper that will help you find a solution. Visit www.colorcoat-online.com/technical to download the papers.

For more information about Tata Steel Colorcoat® products and services visit www.colorcoat-online.com or call the Colorcoat Connection® helpline on +44 (0)1244 892434.



Client: Gwynedd Skip Hire

Architect: EWP

Cladding system: Trisomet® 333 System

Colorcoat® product: Colorcoat Verso®
in Goosewing Grey

Site guidance

This guide assumes that all current safety regulations are in place before the installers commence work.

Maximum number of panels within a pack for varying panel lengths

Core thickness (mm)	Panel length (m)	No. of panels
40	2-7.5	19
	7.5-8	17
	8-9.5	15
	9.5-13	13
	13-16	9
60	16-20	7
	2-10	13
	10-11.5	11
	11.5-14.5	9
80	14.5-18.5	7
	18.5-20	5
	2-10	11
	10-13	9
	13-17.5	7
100	17.5-20	5
	2-12	9
	12-16	7
120	16-20	5
	2-16	7

Packaging

The number of panels in each pack will vary with the length of the panel to ensure stability (see table below). Typically, panels are packed in stacks up to 1,100mm high. The panels are protected at the base of the pack by a timber pallet and are plastic wrapped in the factory. If required, panels can be grouped and referenced for particular areas of the building (e.g. grid line, elevation reference). As standard, each pack is labelled with the order reference number, the number of panels and the panel length.

Receipt of materials on-site

All materials arriving on-site must be checked promptly before off loading. Checks should be made against the relevant delivery notes to ensure that the correct quantities and specifications have been delivered and to determine any possible transportation damage. Any discrepancies or damage observed should be recorded immediately on the proof of delivery paperwork, and a written report should be submitted within 21 days. Please note that off loading is the customer’s responsibility.

Off loading

Wherever possible, the Trisomet® 333 System should be off loaded directly from the vehicle to the area where they will be used to reduce the risk of on-site damage. Off loading is to be undertaken as per Tata Steel recommendations. If panels are to be stored before installation, they should be placed on level ground (in accordance with storage instructions opposite).

There are two recommended methods for off loading:

- **Forklift or telehandler:** These can be used when off loading panels less than 6m long. Care must be taken not to tip or damage the bottom panel when driving on uneven ground. Only **one** pack at a time should be unloaded. Open forks fully before lifting.
- **Crane:** Where slings or grabs are used, precautions should be taken to prevent edge damage and to avoid pressure across the panels, which may cause distortion (chains should not be used). When lifting panels over 6m long, a spreader bar with sufficient hoisting belts to spread the load should be used. If required, temporary edge protection can be installed to prevent local damage. Only **one** pack at a time should be off loaded.

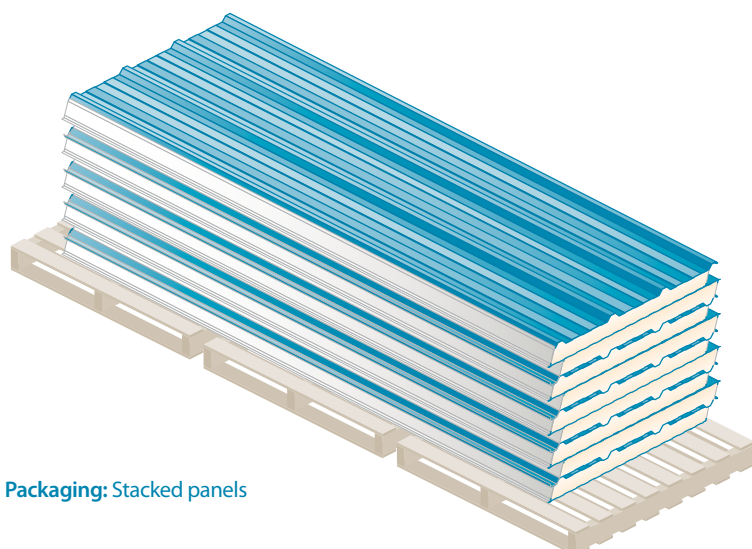

Packaging: Stacked panels

Storage

In addition to the guidelines above, the bundles should be stored on level ground (e.g., a floor slab). The packs should never be stacked more than two high. There should be adequate separation between stacks to provide access and to avoid end damage.



1. Do not stand uncovered stacks in the open. Store under cover and away from open doorways.



2. If stacks cannot be stored under cover, erect a simple scaffold around them and cover it with a waterproof sheet, tarpaulin or polythene. Leave space between the cover and stacks to allow air to circulate.



3. Store stacks off the ground and on a slope, so that if rain penetrates the cover, the water will drain away.



4. Inspect the storage site regularly to ensure that moisture has not penetrated the stack.



5. Do not store sheets where people will walk across them.

Pre-erection checks

A secondary support structure is required to support the cladding system at the necessary positions and transfer all loads imposed on and by the cladding system back to the primary structure.

Before any work starts, a full survey or inspection should be carried out to ensure that the support steelwork and any other associated materials, is correctly positioned and within tolerance so that the Trisomet® 333 System can be fixed correctly. Any obvious problems should be immediately reported to the main contractor to enable remedial work to be undertaken before installation of the cladding.

Tata Steel recommend the allowable variation in the outer flange level of the purlin/rail with respect to the datum line is $L/400$ (where L is the rail spacing).

Further guidance on steel work tolerance can be found in a Steel Construction Institute publication P346: *Best Practice for the specification in installation of metal cladding and secondary steelwork*.

Handling

Wherever possible, manual handling should be avoided and mechanical handling equipment should be used. Mechanical handling provides health and safety benefits, shorter installation times, smaller installation teams and less risk of panel damage.

Recommended suppliers

Gould Plant Hire
T: +44 (0) 1527 570111

4 Cladding Services
T: 0870 7417600

Cutting

For making small cut-outs, openings and cuts that are not straight, use a jigsaw or a reciprocating saw. For longer straight cuts, we recommend using a circular saw that produces a cold cut with a fine-tooth metal cutting blade (i.e., not a grinding blade, as this hot cut will damage the coating). All cutting should be undertaken at ground level.



Roof applications

Model specification

NBS Plus

H43 Insulated panel cladding/ covering

120 Insulated steel faced roof panel:

Tata Steel, LPCB approved

Trisomet® 333 System.

Cladding systems in England and Wales to be designed and installed to meet the Building Regulations 2000, Approved Document L2 2010.

Cladding systems in Scotland to be designed and installed to meet the Building Standards (Scotland) Regulations

Technical Handbook: Section 6 Energy.

- **Support structure:** Steel purlins.
- **Bearing width (minimum):** 60mm end lap extension plates maybe require where 3 or more panels comprise the total roof slope.
- **Pitch:** 4 degree minimum.
- **Manufacturer:** Tata Steel, Shotton, Deeside, Flintshire, CH5 2NH. Technical Department: 0845 30 88 330
- **Product reference:** Trisomet® 333 System.
- **Fire:** LPS1181 Grade EXT-B Certificate No. 460a/07 Issue 14. Internal lining Class O as tested to with BS 476 parts 6 and 7. Class B s2 in accordance with EN 13501-1. External face Class AA in accordance with BS 476-4.
- **Fragility:** Class B in accordance with ACR (M) 001:2005.

- **British Board of Agrément (BBA):** Colorcoat® to BBA Certificate No. 91/2717.
- **Confidex Sustain®:** Confidex Sustain® is a combined guarantee which covers the durability of the Colorcoat® pre-finished steel product and makes the pre-finished steel building envelope CarbonNeutral®. Unavoidable CO₂ emissions from the pre-finished steel cladding system including fixings and insulation are measured from cradle to cradle and the impact offset.
- **External facing material:** Colorcoat HPS200 Ultra® pre-finished steel using Galvalloy® hot-dip metallic-coated steel substrate, 0.5mm nominal thickness, based on a zinc (95%): aluminium (5%) eutectic alloy manufactured to BS EN 10326: 2004 S220GD.
- **External profile:** 32mm high trapezoidal profile with a 333mm pitch.
- **Colour:** See Colorcoat HPS200 Ultra® range of colours.
- **Internal facing material:** Colorcoat® PE 15 pre-finished steel using hot-dip galvanised steel EN 10326:2004 substrate, nominal thickness 0.4 mm.
- **Internal profile:** Lightly planked.
- **Core insulation:** PIR closed cell foam (CFC and HCFC free, zero ODP and GWP <5) to specification used in LPCB approval.
- **Cover width:** 1,000mm.
- **Panel thickness:** 40, 60, 80, 100 or 120mm.
- **Primary fasteners:** Austenitic stainless steel self-drilling fasteners with thread free zone and 19mm sealing washers from EJOT UK Limited, T: +44 (0) 1977 687040, SFS intec Ltd, T: +44 (0) 113 208 5500 or Ash & Lacy Building Systems, T: +44 (0) 121 525 1444.
- **Fastener location:** Fix-through profile trough.
- **Number and location of fasteners:** Fix using one fastener either side of the profile rib at end-lap positions (i.e., six fasteners per support). At all other support positions, locate in the centre of every trough at both sheet ends and intermediate supports (i.e., three fasteners per support).
- **End-lap size (minimum):** 150 mm.
- **End laps:** Stitching not required.
- **Side laps to be stitched at 450mm centres:** Austenitic stainless steel self-drilling fasteners with 14mm sealing washers from EJOT UK Limited, T: +44 (0) 1977 687040, SFS intec Ltd, T: +44 (0) 113 208 5500 or Ash & Lacy Building Systems, T: +44 (0) 121 525 1444.
- **U-value:** 0.45 W/m²K for 40mm panel; 0.32 W/m²K for 60mm panel; 0.25 W/m²K for 80mm panel; 0.20 W/m²K for 100mm panel; or 0.16 W/m²K for 120mm panel.



General requirements

170 Design

Roof cladding to be designed to comply with design and installation guidance in the Tata Steel literature.

172 Thermal bridging

To reduce thermal bridging follow the construction details found in the Tata Steel literature.

300 Profile fillers:

- **Material:** EPDM.
- **Colour:** Black.
- **Thickness:** 25mm.
- **Fixing:** Compression fix between sheets and flashings/supports. Seal into place as top and bottom with gun grade silicon mastic.

480 Flashing and trim details

- **System type:** Use Tata Steel construction details to reduce thermal bridging.
- **Material and finish:** To match outer sheet, 0.7mm minimum gauge.
- **Manufacturer:** Tata Steel, T: +44 (0) 845 30 88 330.
- **Lap joint treatment:** End joints to be lapped by 150mm and sealed, unless specified otherwise. Where possible, arrange with laps away from the prevailing wind. Where butt joints are required, butt joint and seal flashings and/or trims on 150mm wide butt straps made from sheet of the same material and finish.
- **Method of fixing:** Fix to cladding with sealed rivets or integral nylon colour-headed austenitic stainless steel self-drilling fasteners at 450mm minimum centres, supplied by EJOT UK Limited,

T: +44 (0) 1977 687040, SFS intec Ltd,
T: +44 (0) 113 208 5500 or Ash & Lacy
Building Systems T: +44 (0) 121 525 1444.

- **Design:** Maximum unstiffened leg on flashing to be 200mm. Visible free edges to be finished with a stiffened edge or welt.

550 Sealing laps on external sheets

- **Sealant tape:** 6x5mm high grade butyl mastic (25 year guarantee) supplied by EJOT UK Limited, T: +44 (0) 1977 687040, SFS intec Ltd, T: +44 (0) 113 2085 500 or Ash & Lacy Building Systems T: +44 (0) 121 525 1444.
- **Position:** Position sealant in straight, unbroken lines across the profile. Place into troughs. Do not allow to stretch or to sag into position.

- **Seal quality:** Ensure continuity and effectiveness of seal, especially at corner of sheets.

- **End-lap sealant-tape positions:** Three lines of butyl mastic (25 year guarantee) should be placed between sheets before fixing: two rows 10mm from the sheet ends at the top and bottom of the lap, and a third downslope of the fixing screw.
- **Side laps:** A continuous run of butyl mastic (25 year guarantee) on weather side of stitching fastener.

554 Air sealing

The panel edges at ridge, eaves and verge must be seated onto a 6mm diameter bead of high grade butyl mastic (25 year guarantee) supplied by EJOT UK Limited, T: + 44 (0) 1977 687040, SFS intec Ltd, T: +44 (0) 113 2085 500 or Ash & Lacy Building Systems, T: +44 (0) 121 525 1444.

The metal lining layer must be reasonably airtight so that the air permeability does not exceed 10m³/h/m² at an applied pressure of 50pa in accordance with the Building Regulations 2000, Approved Document L2 2006. Under laboratory testing sealed liner sheets show evidence of air leakage as low as 0.46m³/h/m². A reasonable practical expectation for a finished system would be 3 to 5m³/h/m². A reasonable practical expectation for a finished system would be 3 to 5m³/h/m². Ensure internal flashings are fully sealed to ensure continuity and effectiveness of seal, especially at corners of sheets such as at roof/wall junctions and at all penetrations of pipes, ducts, etc.



Platinum® System Guarantee Specification

A Platinum® System Guarantee specification needs to be registered prior to tender package being distributed.

Obtaining a free 12 or 25 year Platinum® Guarantee could not be simpler; a Platinum® approved contractor has to install the components as specified in the Platinum® specification and then simply request the free guarantee from Tata Steel. Tata Steel acts as the one point of contact from beginning to end. We will provide you with a detailed NBS specification, warranties for all specified elements and full support for the duration of the warranty period.

Technical Department

For further information or to register your Platinum® System Guarantee Specification please telephone the Technical Department: 0845 30 88 330.

Construction details – roof

The details within this section are recommendations and have been designed to give practical solutions to minimise thermal bridging and air loss at junctions. For each junction detail, Ψ values (psi) and f values have been calculated in accordance with BS EN ISO 10211 and recommendations within MCRMA technical paper 18.

NB. All support steelwork by others.

Side lap

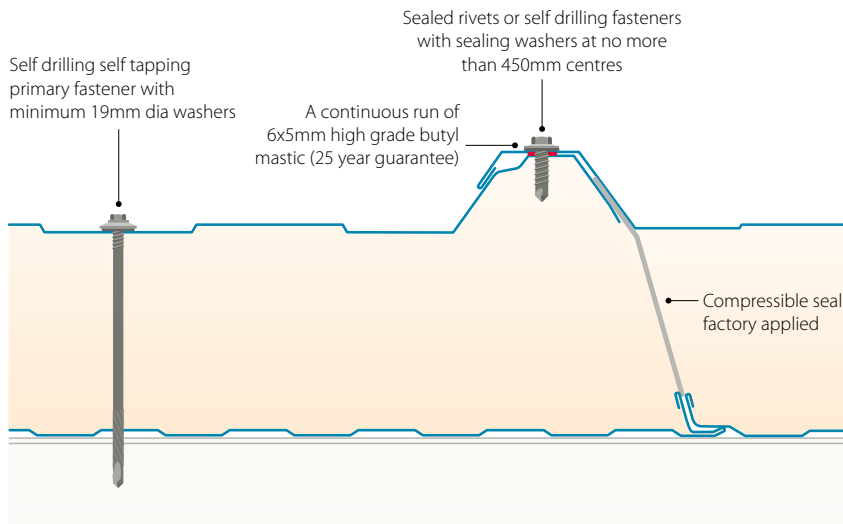

Side lap

The new side lap joint design enables panels to be dropped-in place when side lapping, this provides fast and efficient installation.

End lap

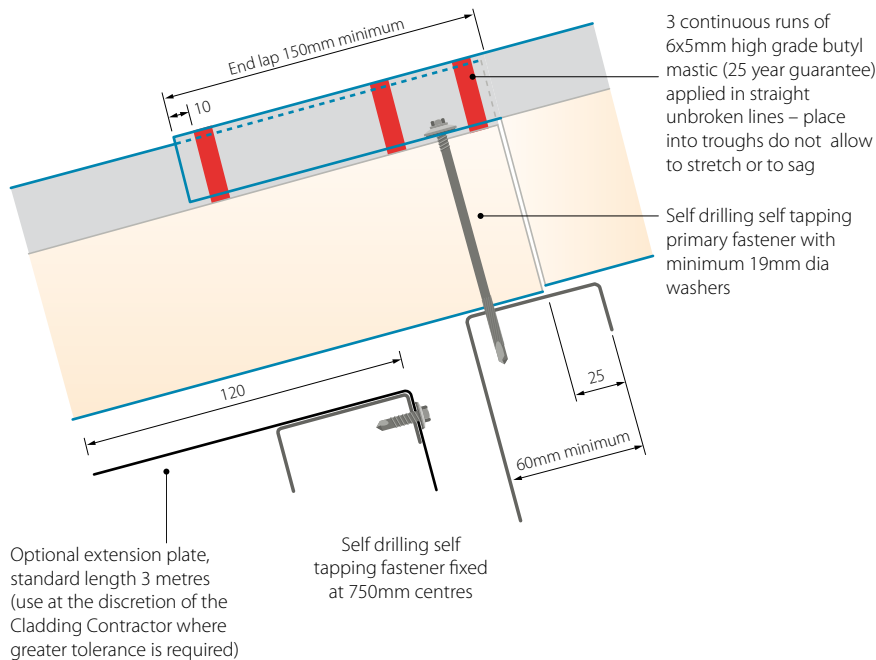

End lap

Six fasteners should be used at the end lap. Fasteners are positioned either side of the profile rib to ensure adequate compression of the seal.

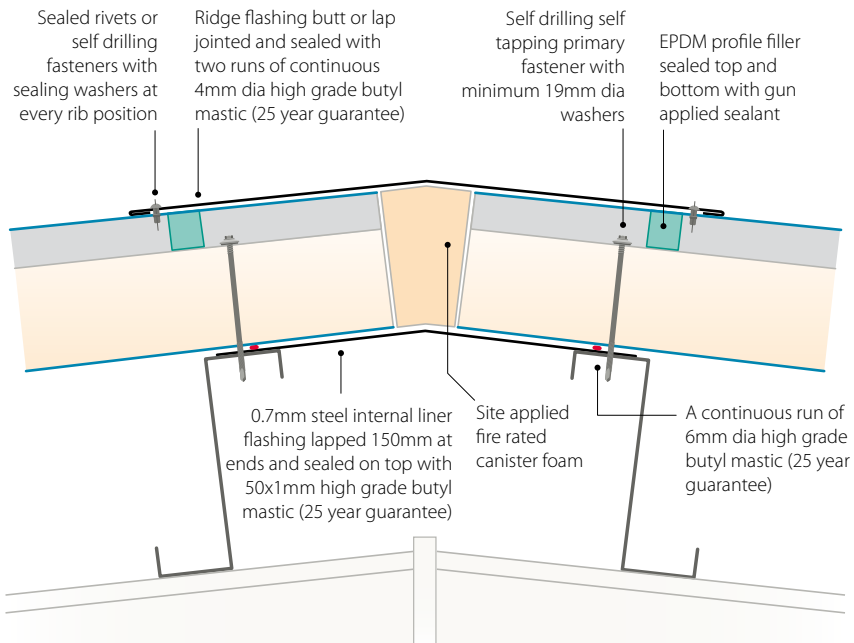

Ridge

Fillers should be positioned back from the edge of the ridge flashing by approximately 80mm to avoid the risk of bird attack.

Psi value (W/mK)	f factor
0.009	0.975

Stated calculation results are dependant on components being as shown. Computer modelled in accordance with EN ISO 10211.

Eaves

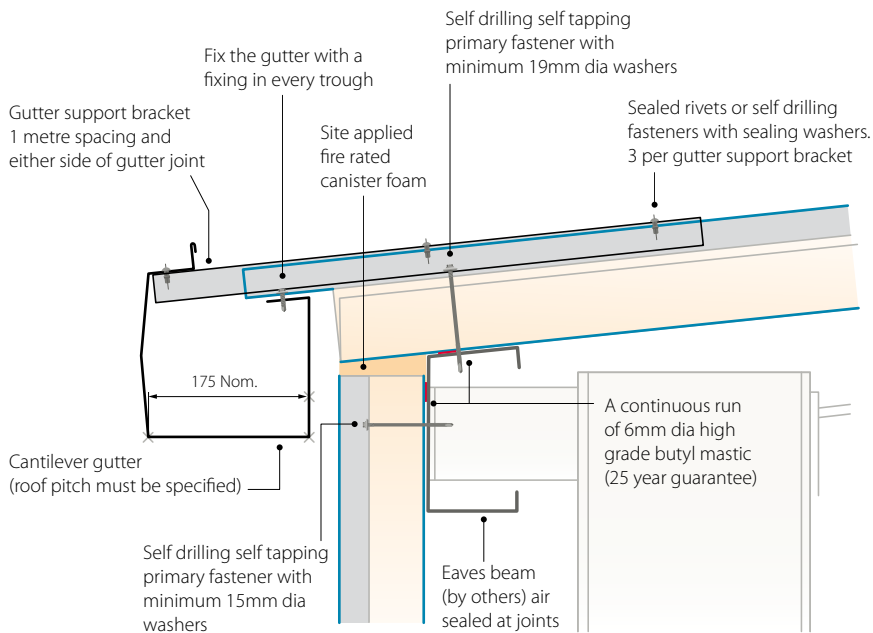

Eaves

The Cantilever Gutter System is manufactured to suit the pitch of the roof and downpipes can be positioned as required.

For further information on the Cantilever Gutter System and assistance with rainflow calculations please contact the Technical Department: 0845 30 88 330.

Psi value (W/mK)	f factor
0.222	0.903

Stated calculation results are dependant on components being as shown. Computer modelled in accordance with EN ISO 10211.

Construction details – roof continued

Parapet

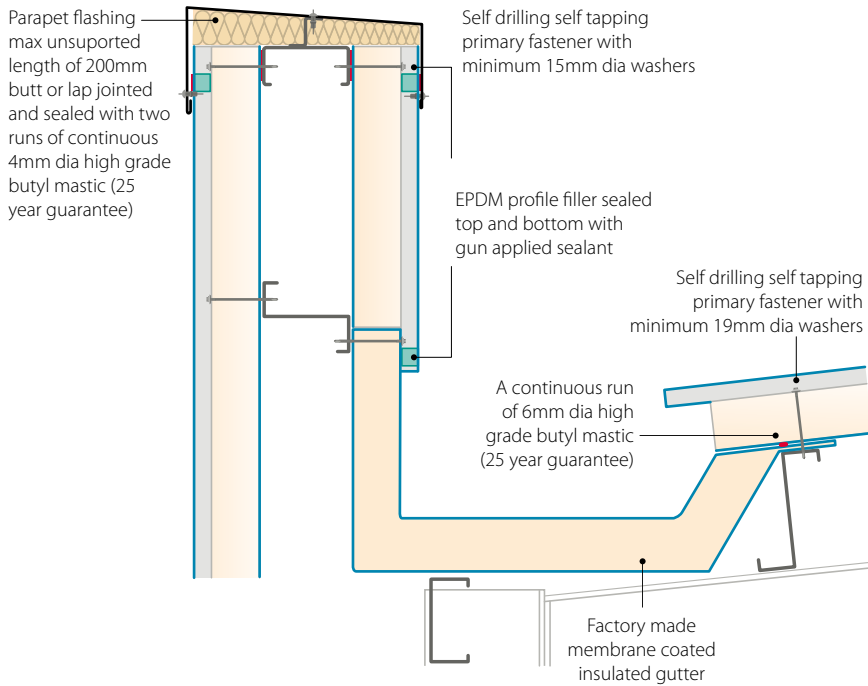

Parapet

The parapet height should be a minimum of 950mm from roof level to be considered as sufficient edge protection as recommended by the HSE.

Psi value (W/mK)	f factor
1.365	0.615

Stated calculation results are dependant on components being as shown. Computer modelled in accordance with EN ISO 10211.

Verge start

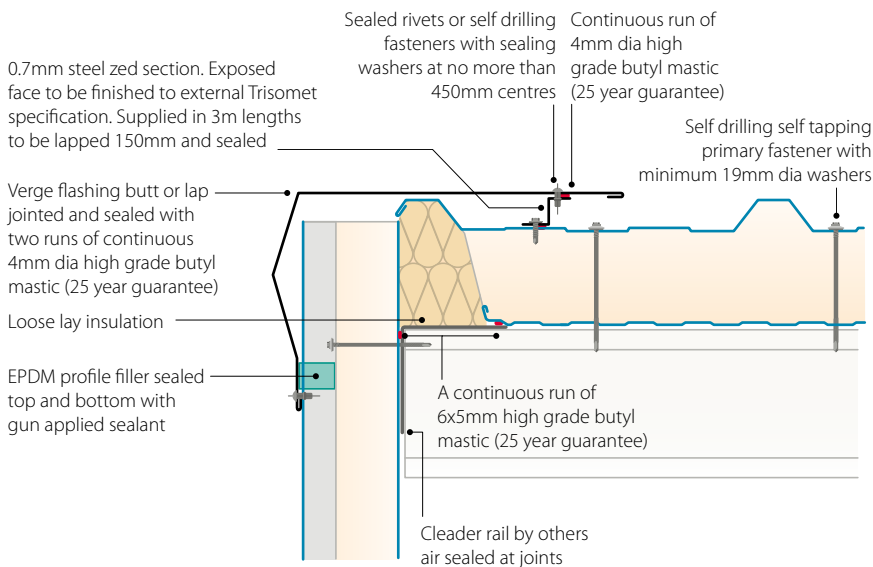

Verge start

The Z section used to support the Verge Flashing is made from the same Colorcoat® material as the external face of the panel, so that it matches the durability performance of the roof.

Psi value (W/mK)	f factor
0.062	0.948

Stated calculation results are dependant on components being as shown. Computer modelled in accordance with EN ISO 10211.

Verge end

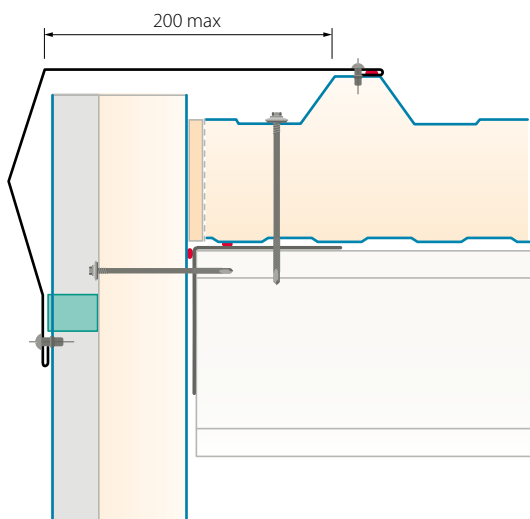
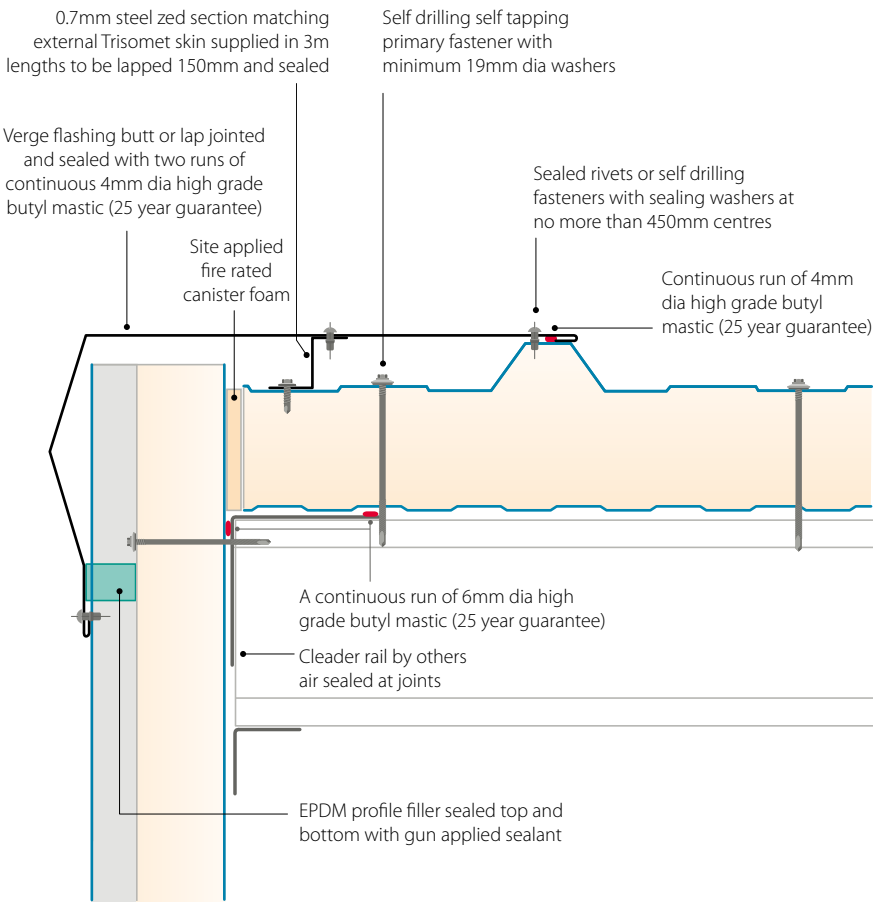

Verge end

It is recommended that single skin flashing have a maximum unsupported leg length of 200mm to maintain the strength for a flat appearance.

Psi value (W/mK)	f factor
0.098	0.948

Stated calculation results are dependant on components being as shown. Computer modelled in accordance with EN ISO 10211.

Construction details – roof continued

Valley gutter

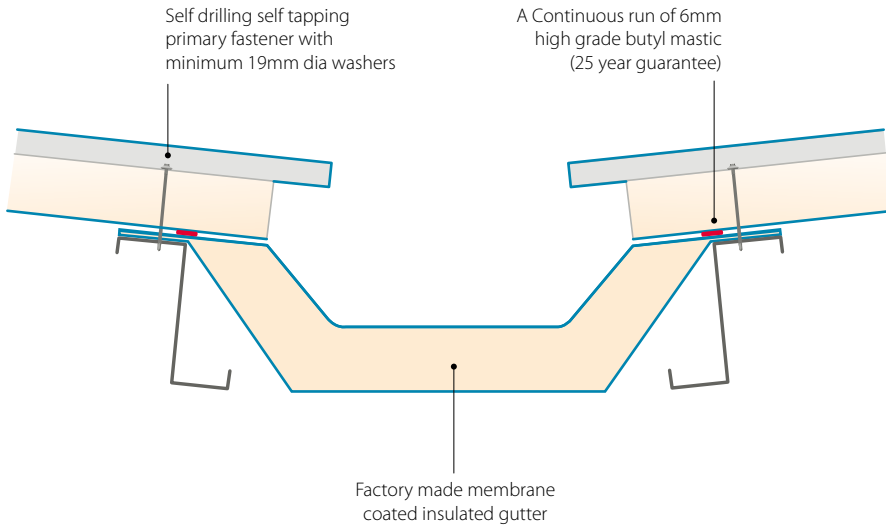

Valley gutter

Ensure a full design is carried out in accordance with BS EN 12056-3:2000 and all manufactures recommendations are followed to ensure correct detailing at this important junction.

Psi value (W/mK)	f factor
0.736	0.559

Stated calculation results are dependant on components being as shown. Computer modelled in accordance with EN ISO 10211.

Valley hip

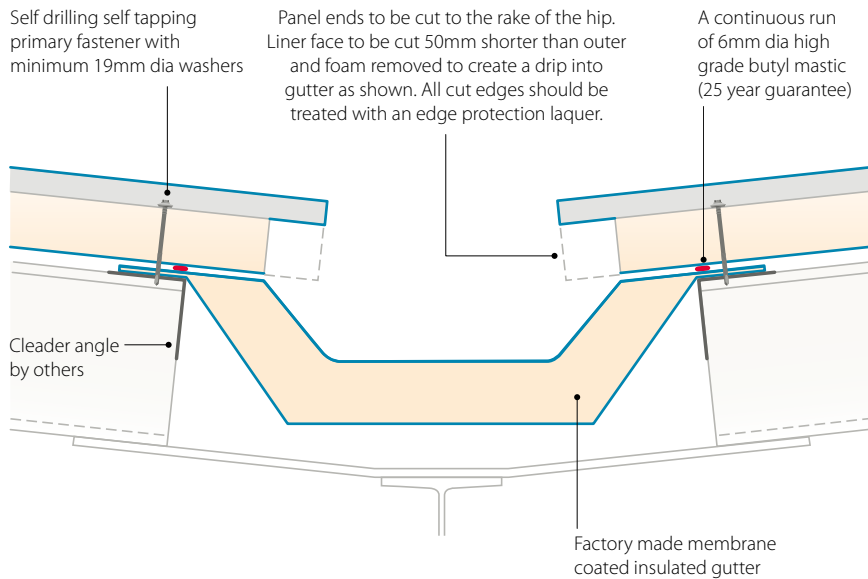

Valley hip

The cut back to the panel end is created to avoid water running down the face of the panel and generating the risk of tracking into the panel side lap.

Psi value (W/mK)	f factor
0.736	0.559

Stated calculation results are dependant on components being as shown. Computer modelled in accordance with EN ISO 10211.

Standard pipe seal (Dektite)

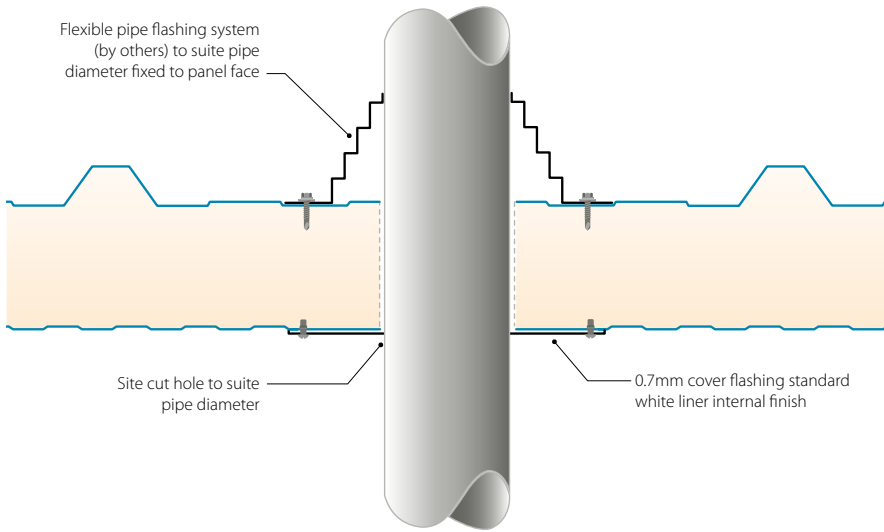

Standard pipe seal and hot pipe seal (Dektite)

The pipe flashings are available in various specifications to facilitate different opening sizes and temperature ranges. Further details on these specifications and for order placement please contact our Platinum® System Guarantee approved suppliers, who are:

SFS intec Ltd, T: +44 (0) 113 2085 500
 or EJOT UK, T: +44 (0) 1977 687040.

Hot pipe seal (Dektite)

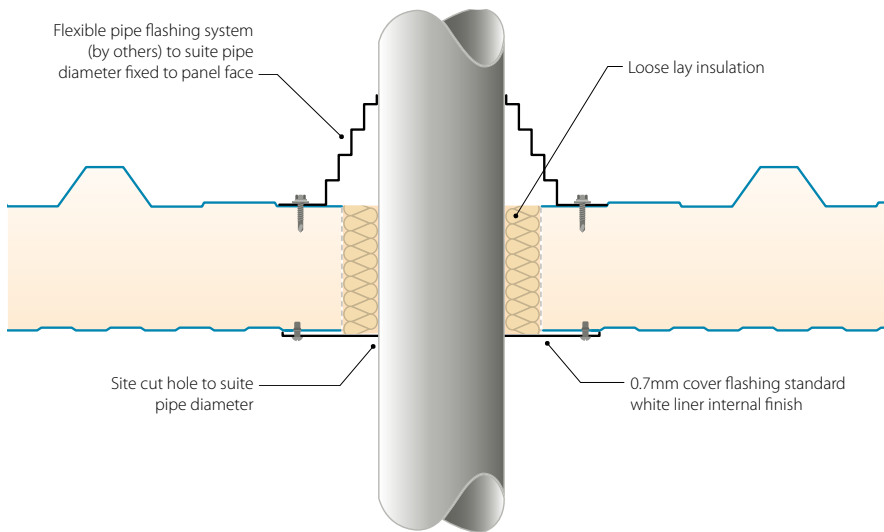

Construction details – roof continued

Velux roof light

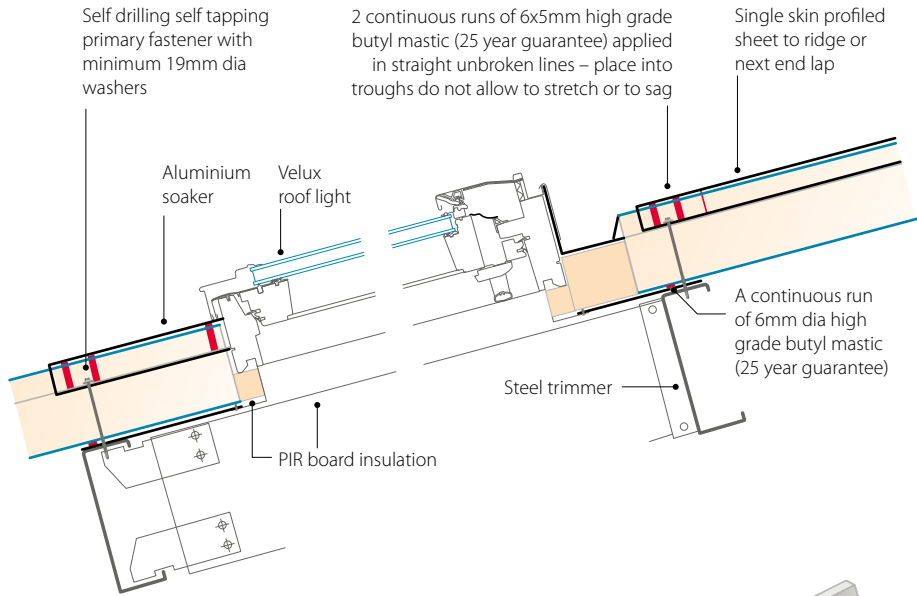

Velux roof light
The detail shown indicates a Velux system. These systems will require specialist advice for installation and maintenance. Therefore Tata Steel recommend that this specialist advice be obtained from Velux, details below.

Velux
T: +44 (0) 1592 778 297
E: velux-gb@velux.com
www.velux.com

Note: correct, width, length and upstand lip should be specified

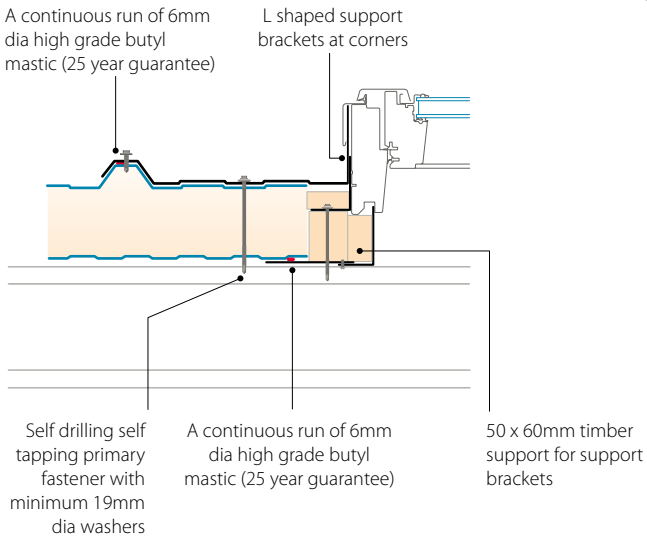
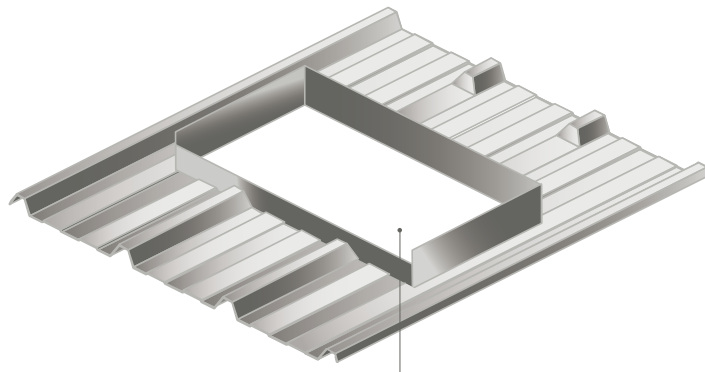

Roof light side lap

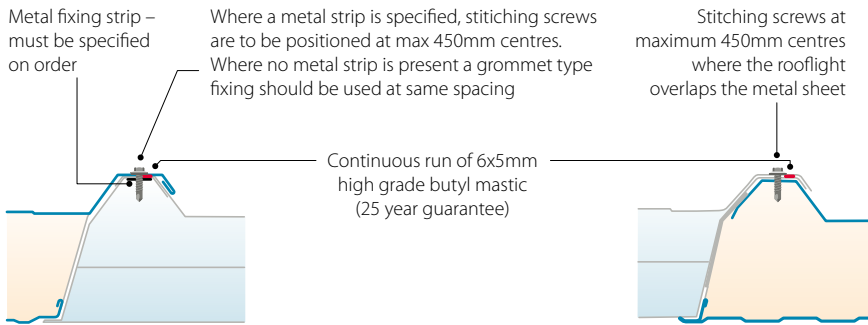

Roof light side lap
In order to achieve a 2.2 W/m²K U-value and comply with the current building regulations for heated buildings a minimum of a triple skin roof light construction should be specified.

Fixing arrangement at an intermediate support

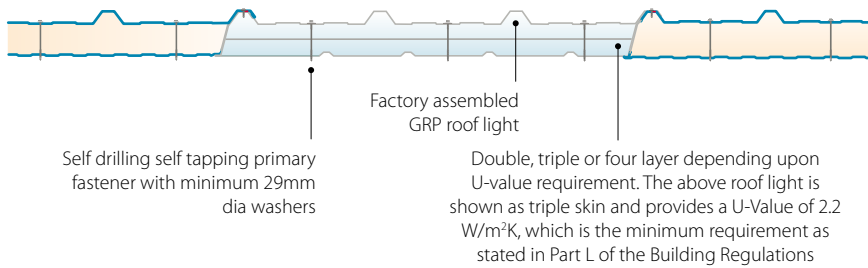

Fixing arrangement at an end lap position



Note: it is not recommended to lap roof lights in series as this may cause misalignment due to varying tolerance between the panel and roof light units.

Roof light end lap

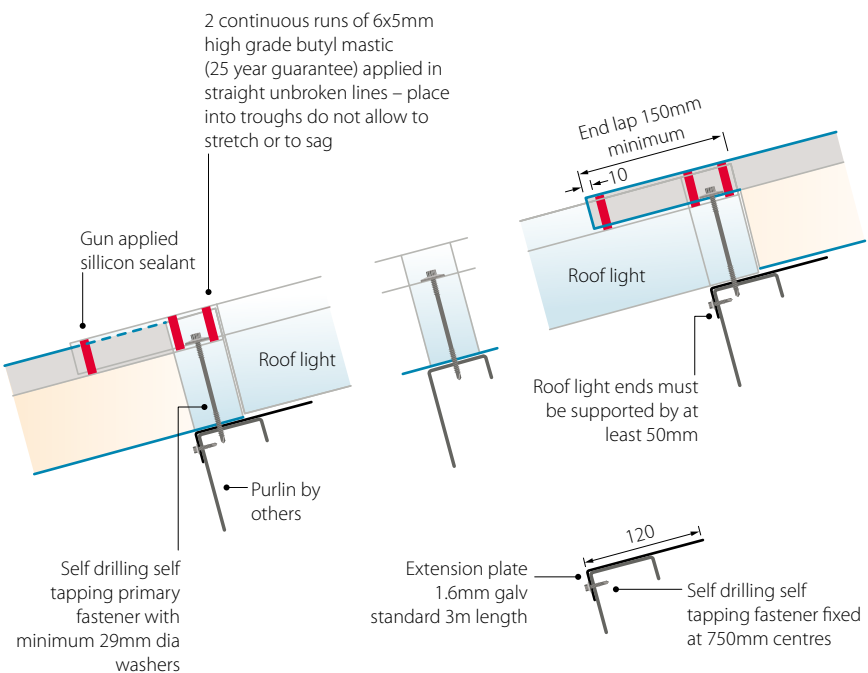

Roof light end lap
When ordering roof lights accurate purlin positions must be provided so fillers can be correctly positioned within the roof light construction.

Construction details – roof continued

Large pipe seal

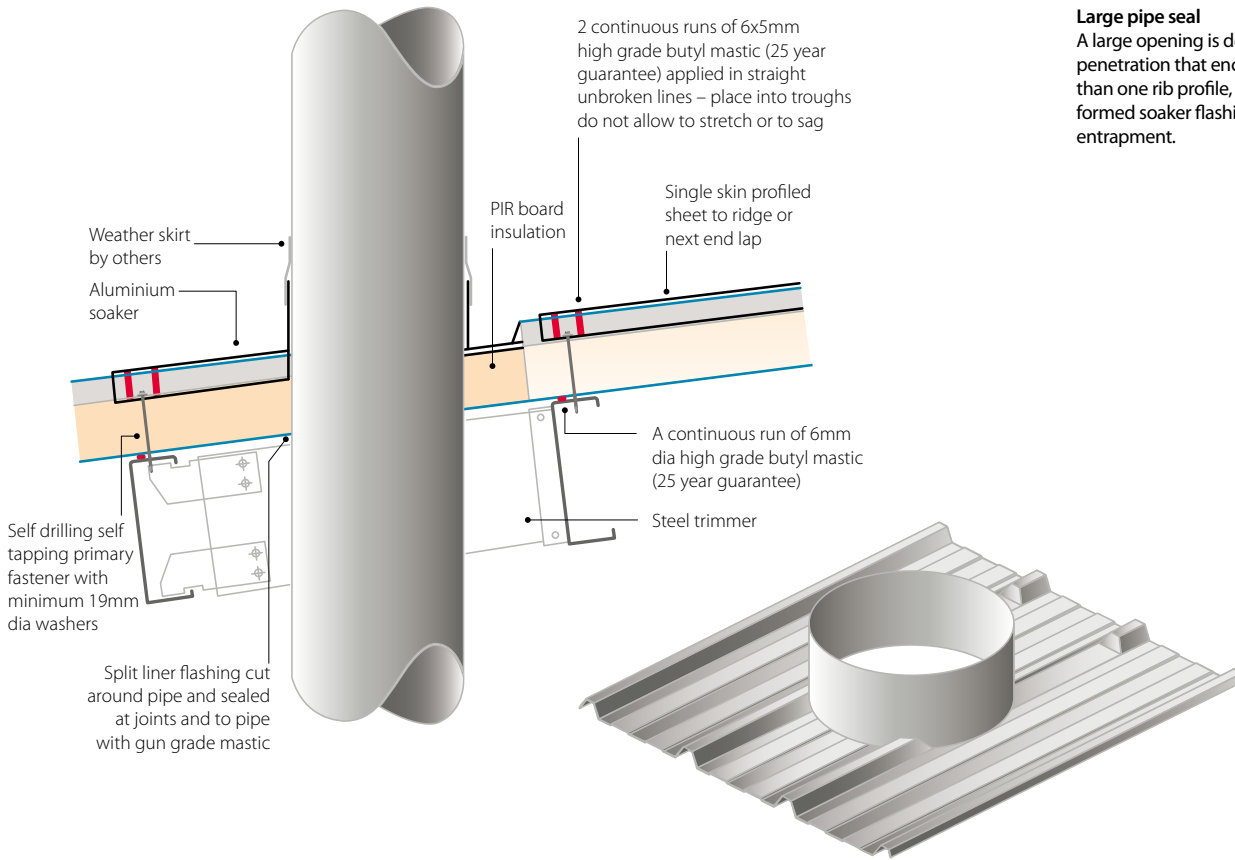

Large pipe seal

A large opening is designated by a penetration that encompasses more than one rib profile, hence requiring a formed soaker flashing to avoid water entrapment.

Smoke vent

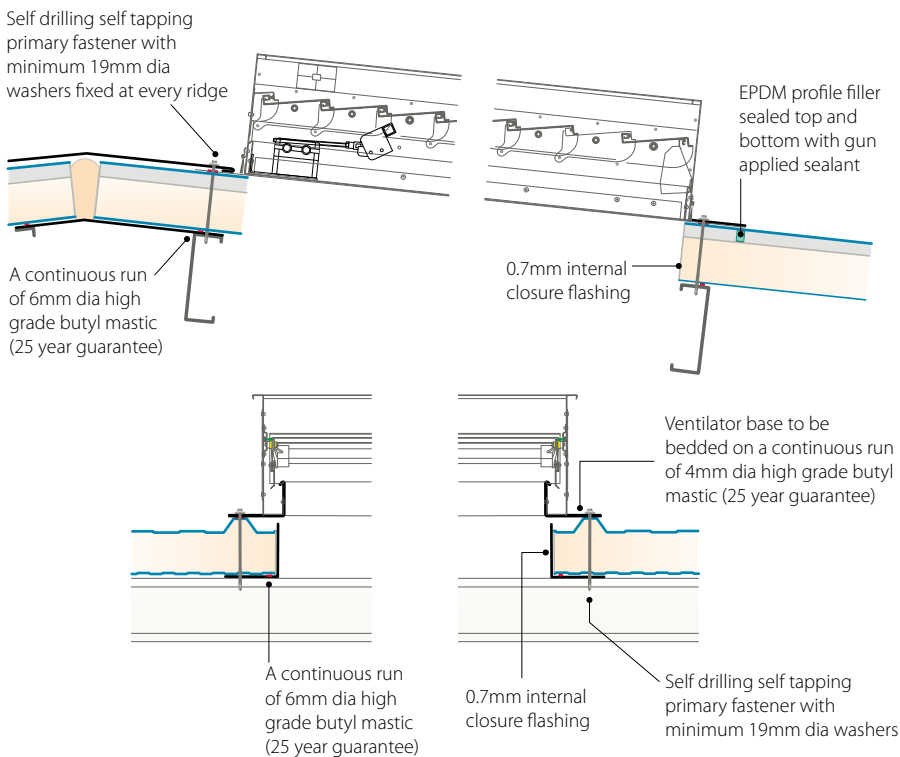

Smoke vent

The detail shown indicates a Colt International system. These systems will require specialist advice for installation and maintenance. Therefore Tata Steel recommend that this specialist advice be obtained from Colt, details below.

Colt International Ltd
T: +44 (0) 2392 451111
E: info@coltgroup.com
www.coltinfo.co.uk

Expansion joint

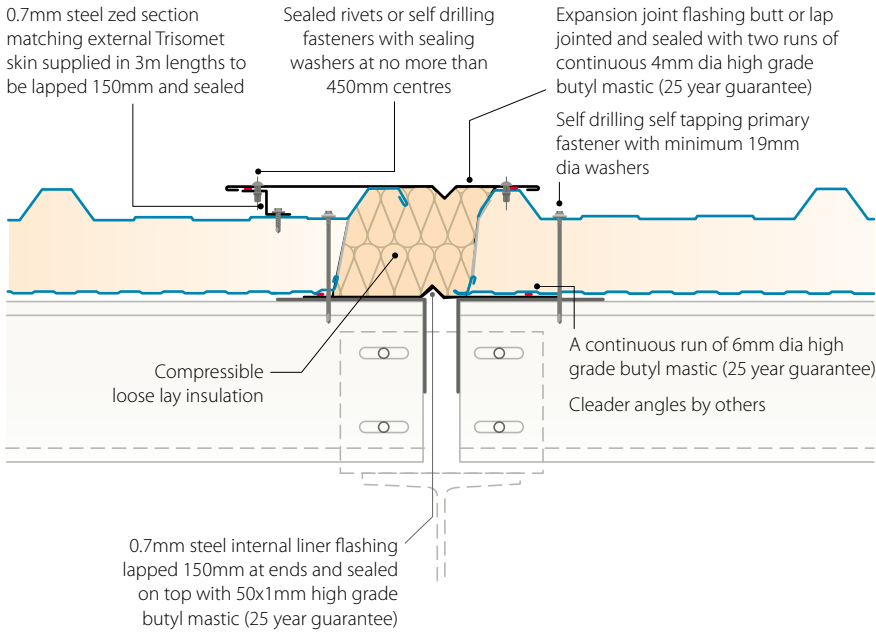

Expansion joint
The 'V' formed flashing allows movement at this junction.

Psi value (W/mK)	f factor
0.024	0.972

Stated calculation results are dependant on components being as shown. Computer modelled in accordance with EN ISO 10211.

Roof to wall junction

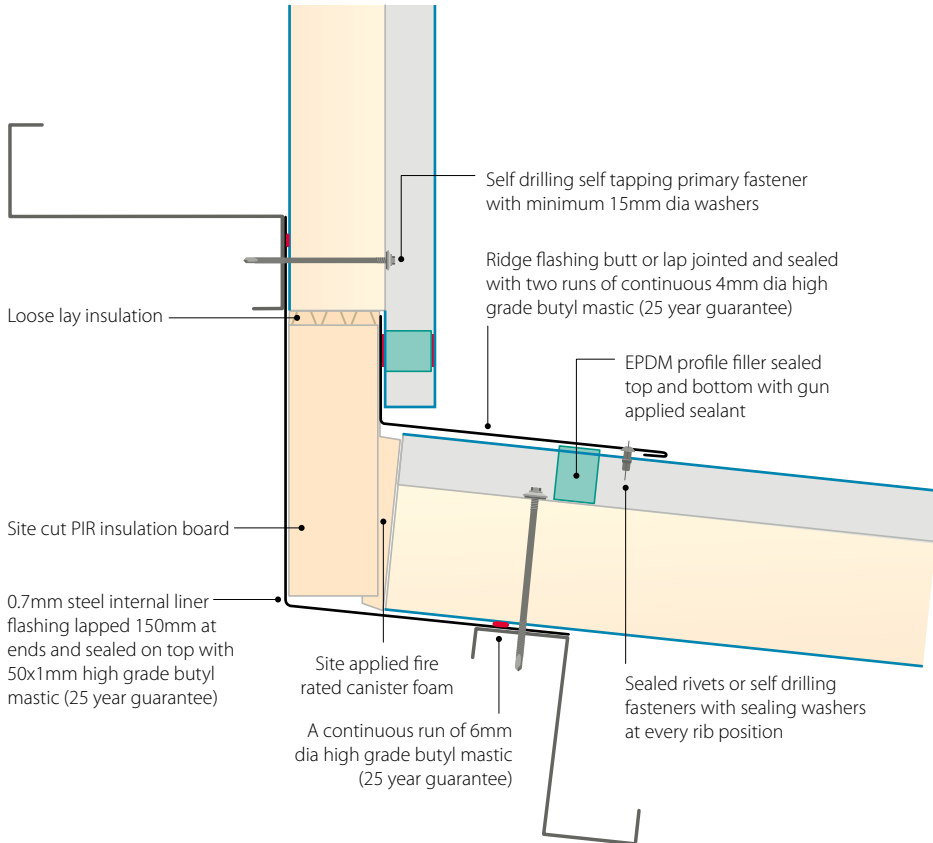

Roof to wall junction
The PIR board is used to provide a comparative level of thermal performance around the junction. The thickness of this board should be selected to match the core thickness of the wall panel. The loose lay insulation is used to the top of the PIR board to allow tolerance when installing the wall panel.

Psi value (W/mK)	f factor
0.019	0.975

Stated calculation results are dependant on components being as shown. Computer modelled in accordance with EN ISO 10211.

Construction details – roof continued

Junction with internal partition with underside of roof

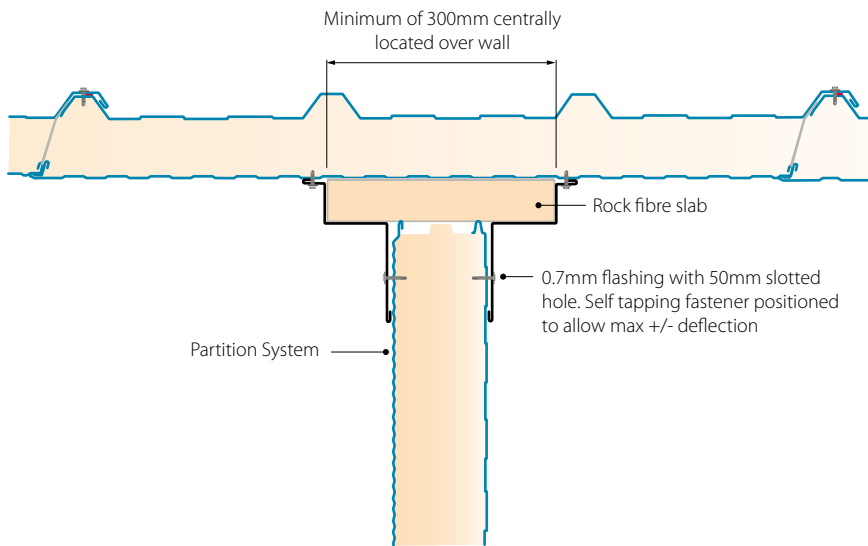

Junction with internal partition with underside of roof

This detail is supported in Approved Document B of the Building Regulations where the following is quoted in Clause 8.3 of Section 8 'Compartmentation'.

'Note: Double-skinned insulated roof sheeting with a thermoplastic core should incorporate a band of material of limited combustibility at least 300mm wide centred over the wall.'

Roof safety system

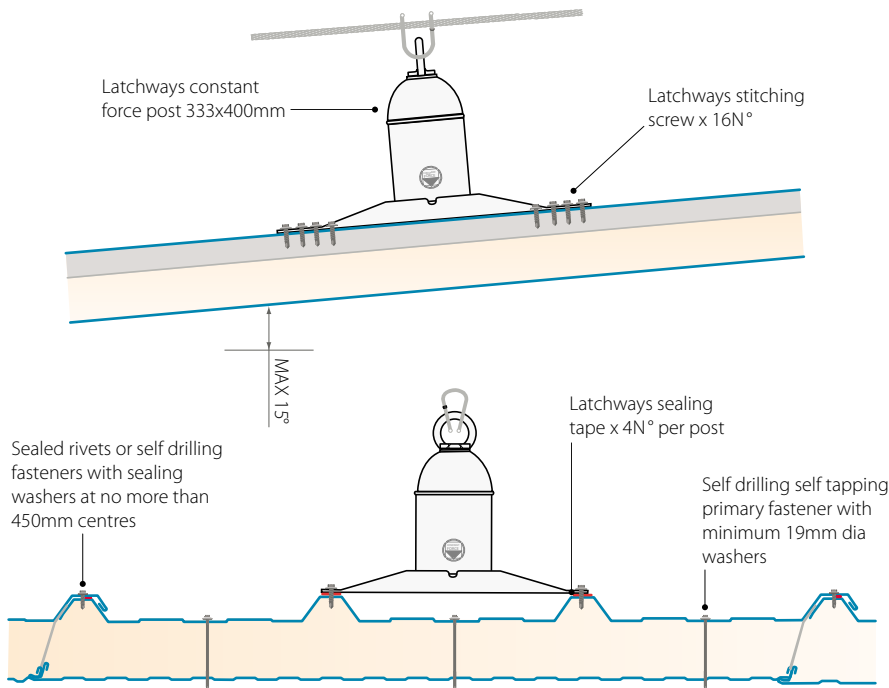

Roof safety system

The detail shown indicates a Latchways system, however an alternative system is also available from QBM. These systems will require specialist roof layout design and installation, together with a maintenance and inspection program. Therefore Tata Steel recommend that this specialist advice be obtained from one of two companies below.

Latchways
T: +44 (0)1380 732700
E: hayley.potter@latchways.com
www.latchways.com

QBM
T: +44 (0)1924 440237
E: technical@qbmdistributors.co.uk
www.qbmdistributors.co.uk

Fasteners, sealants and fillers

Fastener selection table

Primary fixing for Trisomet® 333 System (3-Rib) to steel purlins

Application	Panel core thickness (mm)	SFS intec Ltd	EJOT UK	Ash & Lacy
Cold-rolled purlins, 1.2–3 mm	40	SXCP5-S19-5,5 x 82+ COLOUR	CF19 JT3-D6H 5.5/6.3 x 67+ COLOUR	BM-CPLS082-S19-COLOUR
	60	SXCP5-S19-5,5 x 92+ COLOUR	CF19 JT3-D6H 5.5/6.3 x 107+ COLOUR	BM-CPLS100-S19-COLOUR
	80	SXCP5-S19-5,5 x 113+ COLOUR	CF19 JT3-D6H 5.5/6.3 x 127+ COLOUR	BM-CPLS115-S19-COLOUR
	100	SXCP5-S19-5,5 x 133+ COLOUR	CF19 JT3-D6H 5.5/6.3 x 147+ COLOUR	BM-CPLS135-S19-COLOUR
	120	SXCP5-S19-5,5 x 163+ COLOUR	CF19 JT3-D6H 5.5/6.3 x 167+ COLOUR	BM-CPLS150-S19-COLOUR
Hot-rolled purlins, 4–14 mm	40	SXCP14-S19-5,5 x 80+ COLOUR	CF19 JT3-D12H 5.5/6.3 x 75+ COLOUR	BM-CPHS080-S19-COLOUR
	60	SXCP14-S19-5,5 x 99+ COLOUR	CF19 JT3-D12H 5.5/6.3 x 95+ COLOUR	BM-CPHS105-S19-COLOUR
	80	SXCP14-S19-5,5 x 118+ COLOUR	CF19 JT3-D12H 5.5/6.3 x 115+ COLOUR	BM-CPHS125-S19-COLOUR
	100	SXCP14-S19-5,5 x 134+ COLOUR	CF19 JT3-D12H 5.5/6.3 x 155+ COLOUR	BM-CPHS150-S19-COLOUR
Side-lap stitcher	All	SLP2-S-S14-5.5 x 27+ COLOUR	CF15 JT3-2-6.3 x 25+ COLOUR	
Metal flashings to panel	All	SLP2-S-S14-5.5 x 27+ COLOUR	CF15 JT3-2-6.3 x 25+ COLOUR	

When fixing to timber, fastener pullout values may limit the ability of the roof to resist wind uplift loads. If in doubt, consult the Technical Department 0845 30 88 330.

All fasteners can be sourced from: SFS intec Ltd, T: +44 (0) 113 2085 500, EJOT UK Limited, T: +44 (0) 1977 687040 or Ash & Lacy Building Systems, T: +44 (0) 121 525 1444

Fasteners

The primary fasteners for securing the Trisomet® 333 System roof panel to structural steel purlins have been purpose designed to facilitate speed of fixing give structural security with reduced risk of over compression and have minimal thermal bridging. Time-consuming predrilling of the panel or purlin is not necessary, as the high-thread fastener self drills: the lower thread taps into the purlin and the higher thread taps into the outer skin, thereby clamping the panel securely in a single operation.

Side-lap stitching, should be at maximum of 450mm centres. The stitcher can either be a painted sealed rivet or integral nylon colour headed austenitic stainless steel self-drilling fastener.

When a flashing needs to be secured to the panel, side lap fasteners can be used.

Sealants and fillers

The end lap of the Trisomet® 333 System requires three rows of 6x5mm high grade butyl mastic (25 year guarantee) this generally comes in rolls of 9.6m with 30 rolls per box.

Position the sealant in straight, unbroken lines, following the profile, taking care to avoid any stretch. Ensure the continuity and the effectiveness of the seal, especially at corners of sheets. The three lines of strip sealant must be placed between the sheets before fixing: two rows 10mm from the sheet ends at the top and bottom of the lap, and a third down slope of the fixing screw.

The side lap of the panel is sealed with the same 6x5mm sealant run continuously to weather side of the stitching fastener.

For panel ends at ridges and hips, black EPDM large flute profile fillers should be located between the panel's external skin and the cover flashing to provide continuity of weather seal and to prevent access by insects and small birds. These fillers should be sealed to top and bottom with gun applied solvent release bedding sealant.

All sealants and fillers can be sourced from either: SFS intec Ltd, T: +44 (0) 113 2085 500, EJOT UK Ltd, T: +44 (0) 1977 687040 or Ash & Lacy Building Systems, T: +44 (0) 121 525 1444.

Standard fastener layout for intermediate supports and panel ends

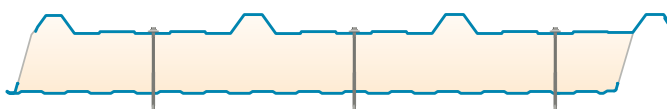

Fastener layout at ends laps

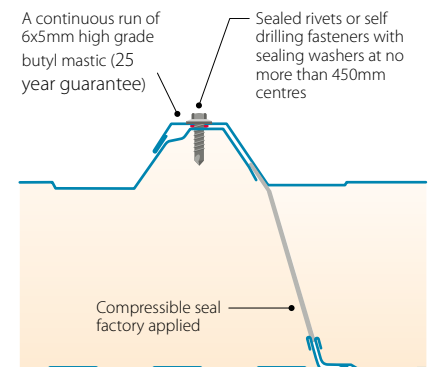
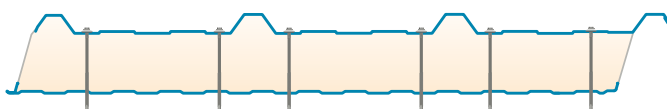

Roof installation

The steps given below are instructions for a typical construction and should be used only as a guide. Specific technical details, method statements and site-specific risk assessments should be produced and applied for each building. An extended list of construction details is available from Tata Steel, and advice can be given via our technical department on any bespoke details that may be required.

The following steps apply to a roof made up of multiple panels with end lap joints. Wherever practical, panels of the same length from ridge to eaves should be used to avoid end laps. This provides a cleaner finish and a more economical installation.

1. Carry out preparation work on internal ridge, internal eaves, trims, etc., and ensure that these are lined and levelled and sealed as specified. Lay down air seals onto the top flange of the eaves beam and the ridge purlins.
2. Position the eaves (or bottom) corner panel, and ensure it is correctly aligned and lapping in the right direction. Wherever possible, the panels should be laid with the exposed joints of the side laps facing away from the prevailing wind (see Figure 1). Fix the panel using primary fasteners in the trough of the trailing edge. Make sure the fasteners are not over tightened and clean away drilling swarf to avoid rust marks.
3. Ensuring that the top of the lower panel (panel 1) is clean and dry, apply three rows of sealant across the panel width with a strip of sealant at the underlap position as shown in the illustration on the next page. The first seal should be placed above the fixing line, the second directly below and the third 10mm from the end of the specified lap (150mm recommended). The seal should be carefully applied to ensure coverage in the corners of the profile.

First panel laid

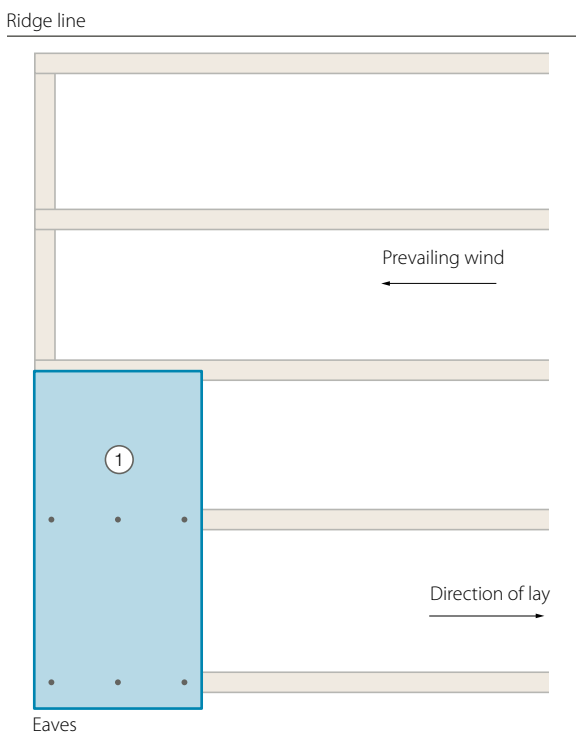

Second panel laid

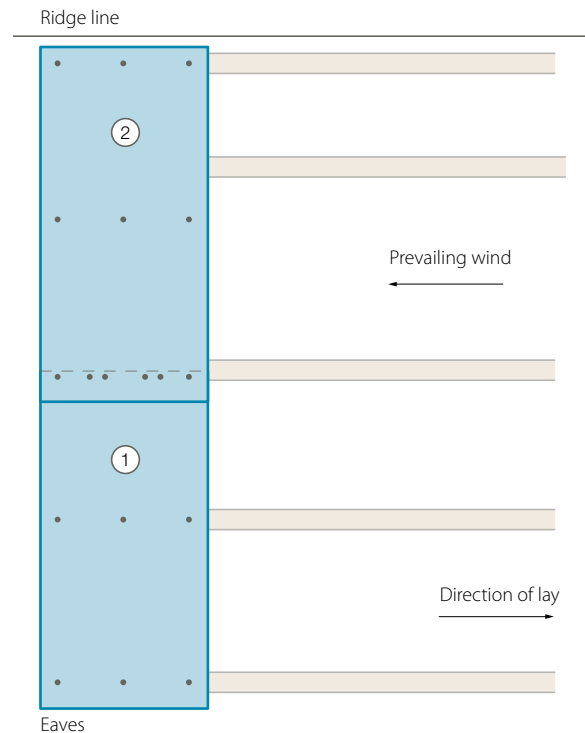

End lap with three rows of sealant

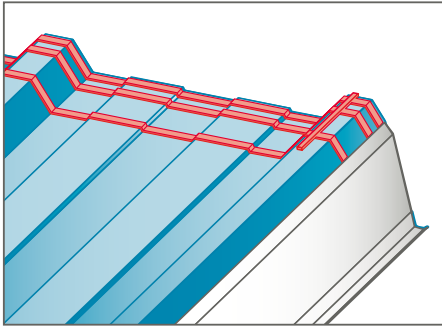

Side lap

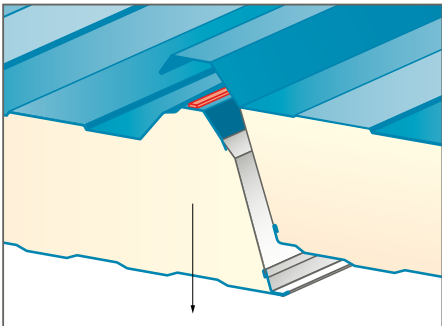

4. Ensure that the cutback of panel 2 is clean and dry before positioning the panel over panel 1. Be careful not to disturb the seals. Align the profiles of the two panels before securing at specified fastener layout.
5. Run the side lap seal continuously from ridge to eaves ensuring this is placed to the weather side of the side lap. Side lap panel 3 by dropping panel into position and securing with specified fastener layout.
6. Apply the end-lap seals as described in step 3.
7. Ensure that the cutback of panel 4 is clean and dry. Position the end of panel 4 over panel 3 and drop down the Side lap as before. Ensure that the profiles of the two panels are aligned before securing into the purlins. Secure the side lap using sealed rivets or stitching screws at a minimum of 450mm centres.
8. Continue steps 5, 6 and 7 until the elevation is complete. Seal and position profile fillers at ridge and fit the external flashings and ensure they are sealed as specified.

Third panel laid

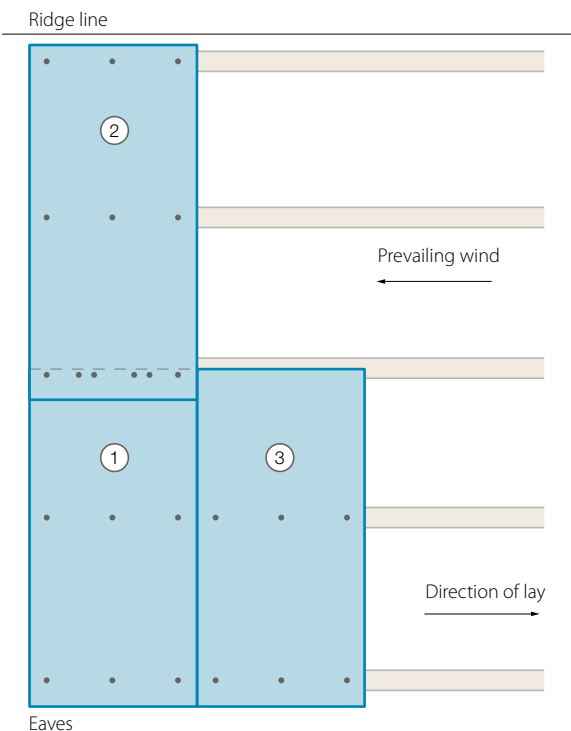

Fourth panel laid

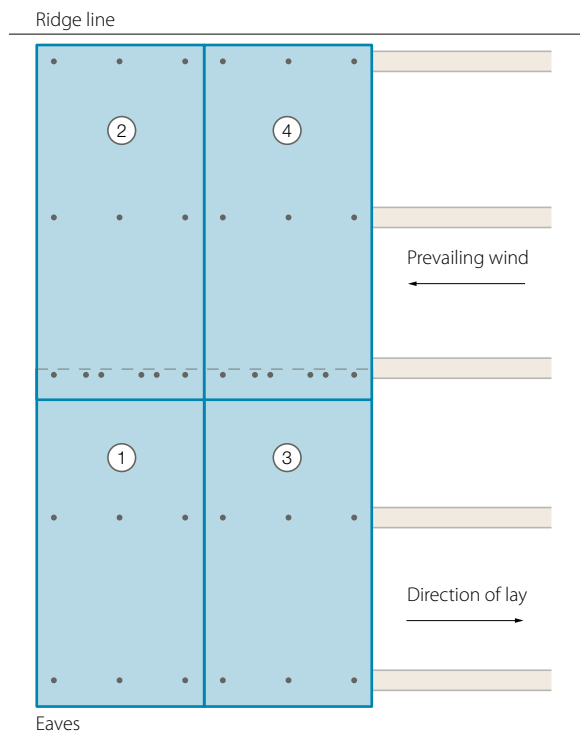

Wall applications

Model specification

NBS Plus

120 Insulated steel faced wall panel:

Tata Steel Tata Steel, LPCB approved Trisomet® 333 System

Cladding systems in England and Wales to be designed and installed to meet the Building Regulations 2000, Approved Document L2 2010.

Cladding systems in Scotland to be designed and installed to meet the Building Standards (Scotland) Regulations Technical Handbook: Section 6 Energy.

- **Support structure:** Cladding rails.
 - **Bearing width (minimum):** 60mm.
 - **Manufacturer:** Tata Steel, Shotton, Deeside, Flintshire, CH5 2NH. Technical Department: 0845 30 88 330.
 - **Product reference:** Trisomet® 333 System.
 - **Fire:** LPS1181 Grade EXT-B Certificate No. 460a/11 Issue 14.
- Fire resistance rating of 30 minutes insulation and 4 hours integrity in accordance with BS 476 part 22 (external stitching screws required at 300mm centres for this classification).
- Class O to the Building Regulations.
Class B s2 in accordance with EN 13501-1.
- **British Board of Agrément (BBA):** Colorcoat® to BBA Certificate No. 91/2717.
 - **Confidex Sustain®:** Confidex Sustain® is a combined guarantee which covers the durability of the Colorcoat® pre-finished steel product and makes the pre-finished steel building envelope CarbonNeutral®.

Unavoidable CO₂ emissions from the pre-finished steel cladding system including fixings and insulation are measured from cradle to cradle and the impact offset.

- **External facing material:** Colorcoat HPS200 Ultra® or Colorcoat Prisma® pre-finished steel using Galvalloy® hot-dip metallic-coated steel substrate, 0.5mm nominal thickness, based on a zinc (95%): aluminium (5%) eutectic alloy manufactured to BS EN 10326: 2004 S220GD.
- **External profile:** 32mm high trapezoidal profile with a 333mm pitch.
- **Colour:** See Colorcoat HPS200 Ultra® or Colorcoat Prisma® range of colours.
- **Internal facing material:** Tata Steel Colorcoat® PE 15 pre-finished steel using hot-dip galvanised steel EN 10326:2004 substrate, nominal thickness 0.4mm.
- **Internal profile:** Lightly planked.
- **Core insulation:** PIR closed cell foam (CFC and HCFC free, zero ODP and GWP <5) to specification used in LPCB approval.
- **Cover width:** 1,000mm.
- **Panel thickness:** 40, 60, 80, 100 or 120mm.
- **Primary fasteners:** Austenitic stainless steel self-drilling fasteners with thread-free zone and 15 mm sealing washers from EJOT UK Limited, T: +44 (0) 1977 687040, SFS intec Ltd, T: +44 (0) 113 208 5500 or Ash & Lacy Building Systems T: +44 (0) 121 525 1444.
- **Fastener location:** Fix-through profile trough.

- **Number and location of fasteners:** At all support positions, locate one fastener in the centre of every trough (i.e., three fasteners per support).
- **End-lap size (minimum):** 100mm vertical, 50mm horizontal.
- **End laps:** Stitching not required.
- **Side laps to be stitched at 600mm centres:** Austenitic stainless steel self-drilling fasteners with 14mm sealing washers from EJOT UK Limited, T: +44 (0) 1977 687040, SFS intec Ltd, T: +44 (0) 113 208 5500 or Ash & Lacy Building Systems T: +44 (0) 121 525 1444.
- **U-value:** 0.46 W/m²K for 40mm panel; 0.33 W/m²K for 60mm panel; 0.25 W/m²K for 80mm panel; 0.20 W/m²K for 100mm panel; or 0.16 W/m²K for 120mm panel.

General requirements

170 Design

Wall cladding to be designed to comply with design and installation guidance in the Tata Steel literature.

172 Thermal bridging

To reduce thermal bridging follow the construction details found in the Tata Steel literature.

300 Profile fillers:

- **Material:** EPDM.
- **Colour:** Black.
- **Thickness:** 25mm.
- **Fixing:** Compression fix between sheets and flashings/supports. Seal into place as top and bottom with gun grade silicon mastic.



480 Flashing and trim details

- **System type:** Use Tata Steel construction details to reduce thermal bridging.
- **Material and finish:** To match outer sheet, 0.7mm minimum gauge.
- **Manufacturer:** Tata Steel, T: +44 (0) 845 856600.
- **Lap joint treatment:** End joints to be lapped by 150mm and sealed, unless specified otherwise. Where possible, arrange with laps away from the prevailing wind. Where butt joints are required, butt joint and seal flashings or trims on 150mm wide butt straps made from sheet of the same material and finish.
- **Method of fixing:** Fix to cladding with sealed rivets or integral nylon colour headed austenitic stainless steel self-drilling fasteners at 450mm minimum centres, supplied by EJOT UK Limited, T: + 44 (0) 1977 687040, SFS intec Ltd, T: +44 (0) 113 208 5500 or Ash & Lacy Building Systems, T: +44 (0) 121 525 1444.
- **Design:** Maximum unstiffened leg on flashing to be 200mm. Visible free edges to be finished with a stiffened edge or welt.

550 Sealing laps on external sheets when laid vertically

- **Sealant tape:** 6x5 mm high grade butyl mastic (25 year guarantee) supplied by EJOT UK Limited T: +44 (0) 1977 687040), SFS intec Ltd, T: +44 (0) 113 2085 500) or Ash & Lacy Building Systems T: +44 (0) 121 525 1444.
- **Position:** Position sealant in straight, unbroken lines across the profile. Place into troughs. Do not allow to stretch or to sag into position.

- **Seal quality:** Ensure continuity and effectiveness of seal, especially at corner of sheets.
- **End lap sealant-tape positions:** Two lines of butyl mastic (25 year guarantee) should be placed between sheets 10mm from the sheet ends at the top and bottom of the lap.
- **Side laps:** A continuous run of 4mm diameter high grade butyl mastic (25 year guarantee) on weather side of stitching fastener.

Sealing laps on external sheets when laid horizontally

- **Sealant tape:** Gun grade silicon sealant supplied by EJOT UK Limited, T: +44 (0) 1977 687040), SFS intec Ltd, T: +44 (0) 113 2085 500 or Ash & Lacy Building Systems, T: +44 (0) 121 525 1444.
- **Position:** Position sealant in straight, unbroken lines across the profile. Place into troughs.
- **Seal quality:** Ensure continuity and effectiveness of seal, especially at corner of sheets.
- **End lap sealant-tape positions:** Two lines sealant should be placed between sheets 10mm from the sheet ends at the top and bottom of the lap.
- **Side laps:** A continuous run of 4mm diameter high grade butyl mastic (25 year guarantee) on weather side of stitching fastener.

554 Air sealing

The panel edges at base, eaves and corners must be seated onto a 6mm diameter bead of high grade butyl mastic (25 year guarantee) supplied by EJOT UK Limited, T: + 44 (0) 1977 687040, SFS intec

Ltd, T: +44 (0) 113 2085 500 or Ash & Lacy Building Systems, T: +44 (0) 121 525 1444.

The metal lining layer must be reasonably airtight so that the air permeability does not exceed 10m³/h/m² at an applied pressure of 50pa in accordance with the Building Regulations 2000, Approved Document L2 2006. Under laboratory testing sealed panels show evidence of air leakage as low as 0.46m³/h/m².

A reasonable practical expectation for a finished system would be 3 to 5m³/h/m². Ensure internal flashings are fully sealed to ensure continuity and effectiveness of seal, especially at corners of sheets such as at roof/wall junctions and at all penetrations of pipes, ducts, etc.



Platinum® System Guarantee Specification

A Platinum® System Guarantee specification needs to be registered prior to tender package being distributed.

Obtaining a free 12 or 25 year Platinum® Guarantee could not be simpler; a Platinum® approved contractor has to install the components as specified in the Platinum® specification and then simply request the free guarantee from Tata Steel.

Tata Steel acts as the one point of contact from beginning to end. We will provide you with a detailed NBS specification, warranties for all specified elements and full support for the duration of the guarantee period.

Technical Department

For further information or to register your Platinum® System Guarantee Specification please telephone the Technical Department: 0845 30 88 330.

Construction details – wall continued

The details within this section are recommendations and have been designed to give practical solutions to minimise thermal bridging and air loss at junctions. For each junction detail, Ψ values (psi) and f values have been calculated in accordance with BS EN ISO 10211 and recommendations within MCRMA technical paper 18.

NB. All support steelwork by others.

Vertical details

Side lap

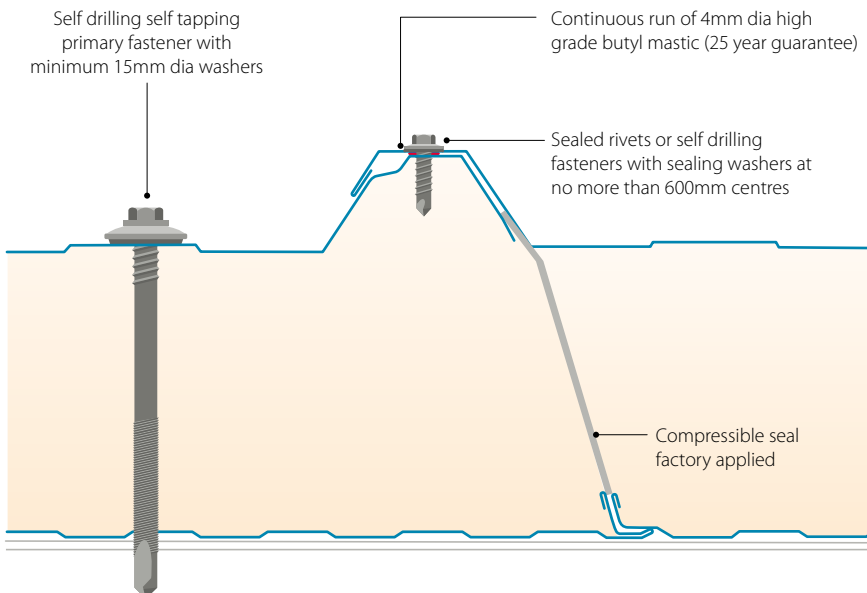

Side lap

The new side lap joint design enables panels to be lapped simply providing fast and efficient installation.

End lap

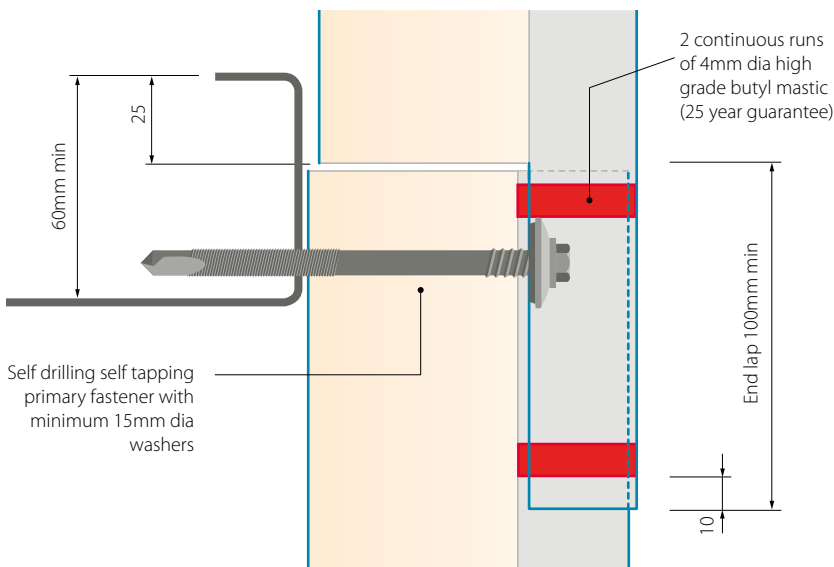

End lap

Three fasteners should be used at the end lap. Fasteners are positioned in the centre of every trough.

Internal corner

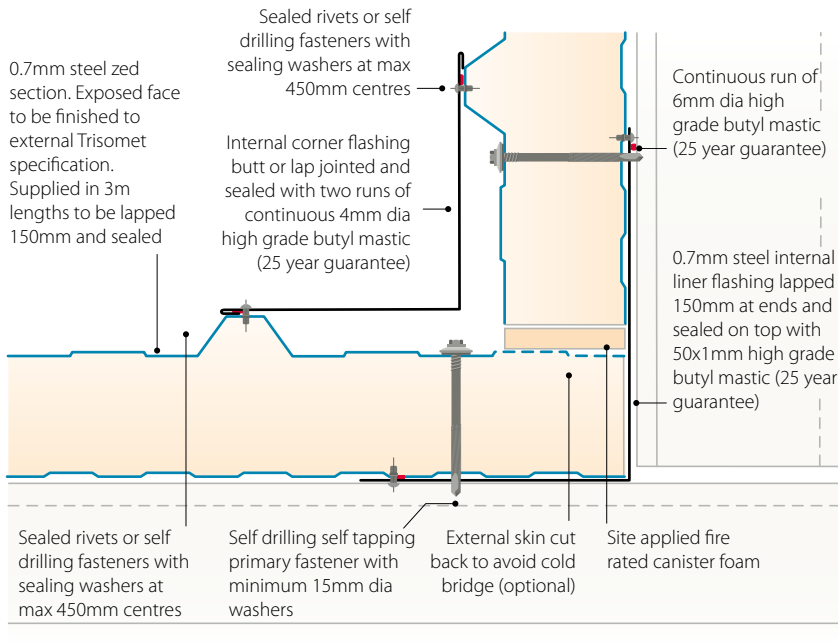

Internal corner

Thermal performance can be enhanced by the on site removal of the panel outer skin, within the corner junction, therefore reducing the risk of cold bridging. The outer skin can be easily removed by running a circular saw through the steel approximately 100mm from the panel edge and then peeling the cut strip away.

Psi value (W/mK)	f factor
With liner cut back	
0.041	0.957
Without liner cut back	
0.092	0.939

Stated calculation results are dependant on components being as shown. Computer modelled in accordance with EN ISO 10211.

External corner

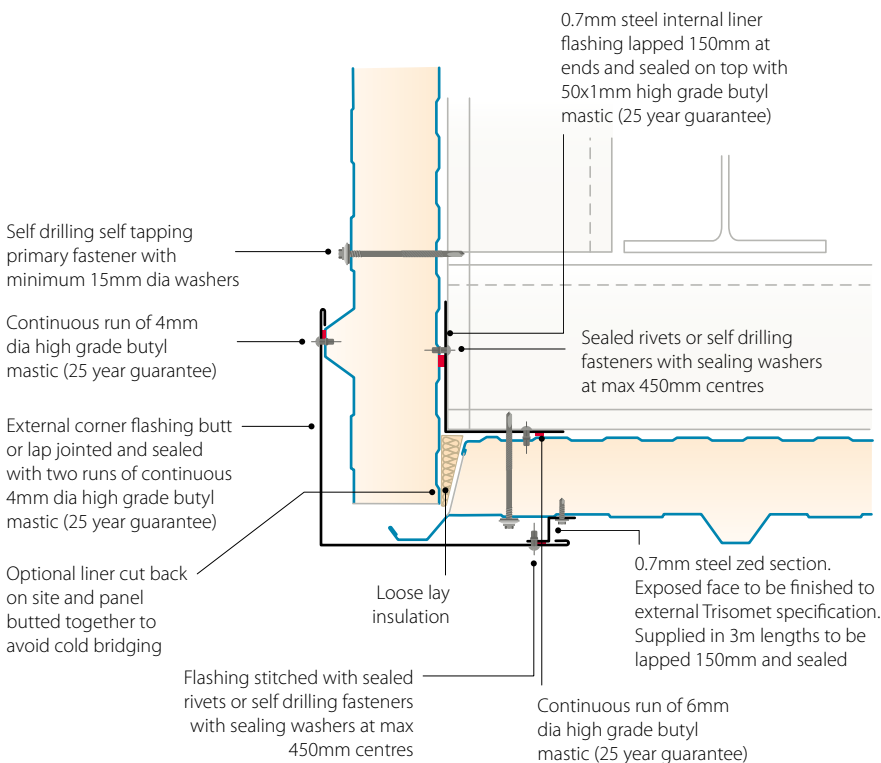

External corner

Thermal performance can be enhanced by the on site removal of the panel liner, within the corner junction, therefore reducing the risk of cold bridging. The liner can be easily removed by running a circular saw through the steel approximately 100mm from the panel edge and then peeling the cut strip away.

Psi value (W/mK)	f factor
With liner cut back	
0.019	0.940
Without liner cut back	
0.092	0.939

Stated calculation results are dependant on components being as shown. Computer modelled in accordance with EN ISO 10211.

Construction details – wall continued

Drip detail base

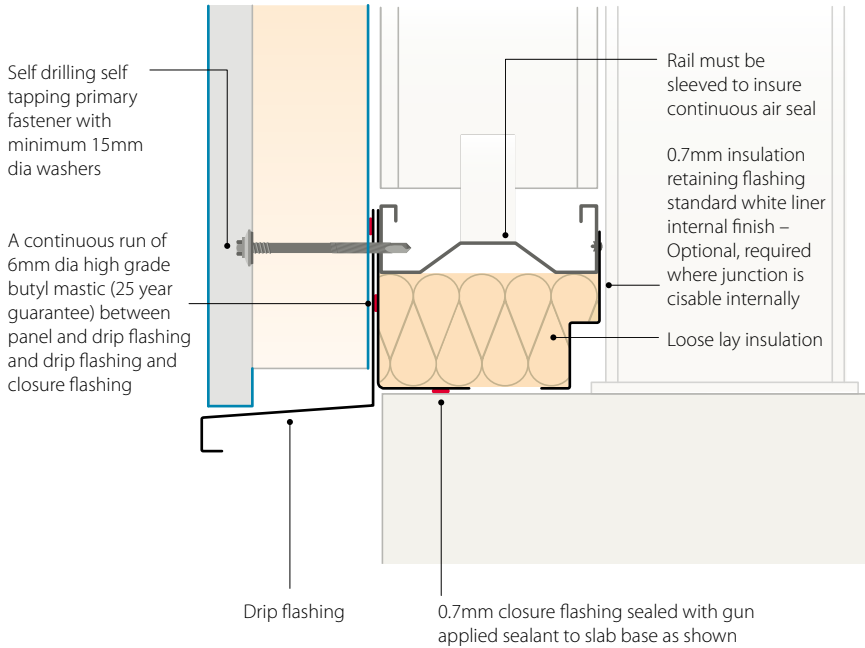

Drip detail base

Loose laid mineral fibre quilt insulation is used below bottom cladding rail to reduce cold bridging at slab base.

Psi value (W/mK)	f factor
0.275	0.687

Stated calculation results are dependant on components being as shown. Computer modelled in accordance with EN ISO 10211.

Drip detail dado wall

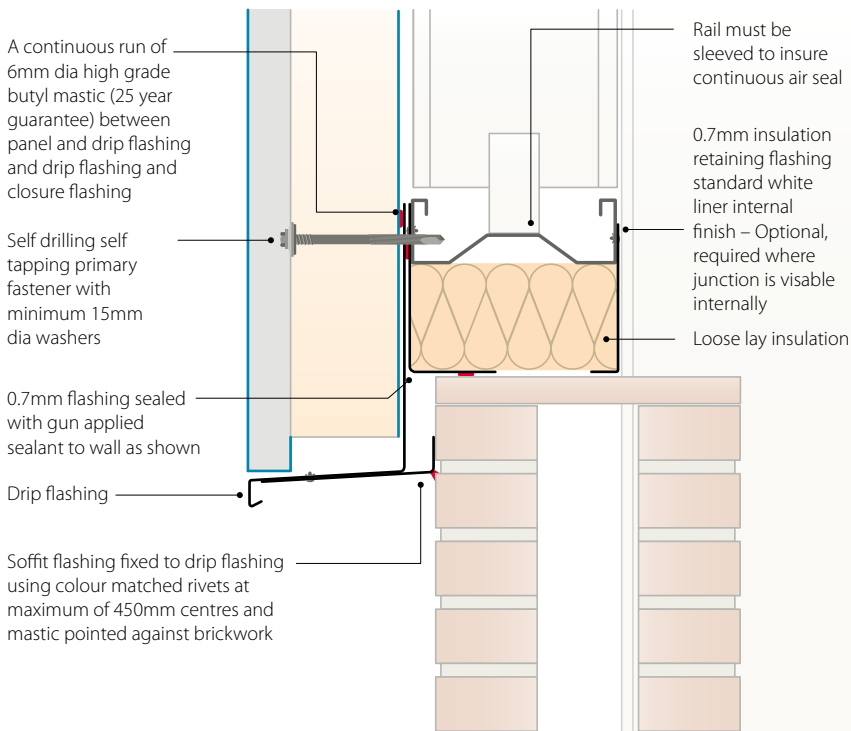

Drip detail dado wall

A 1.6mm galvanised steel support angle is fixed to the wall, level with the base of the panel, in order to facilitate installation and to ensure the panel is level before fixing.

Psi value (W/mK)	f factor
0.062	0.948

Stated calculation results are dependant on components being as shown. Computer modelled in accordance with EN ISO 10211.

Window/door head

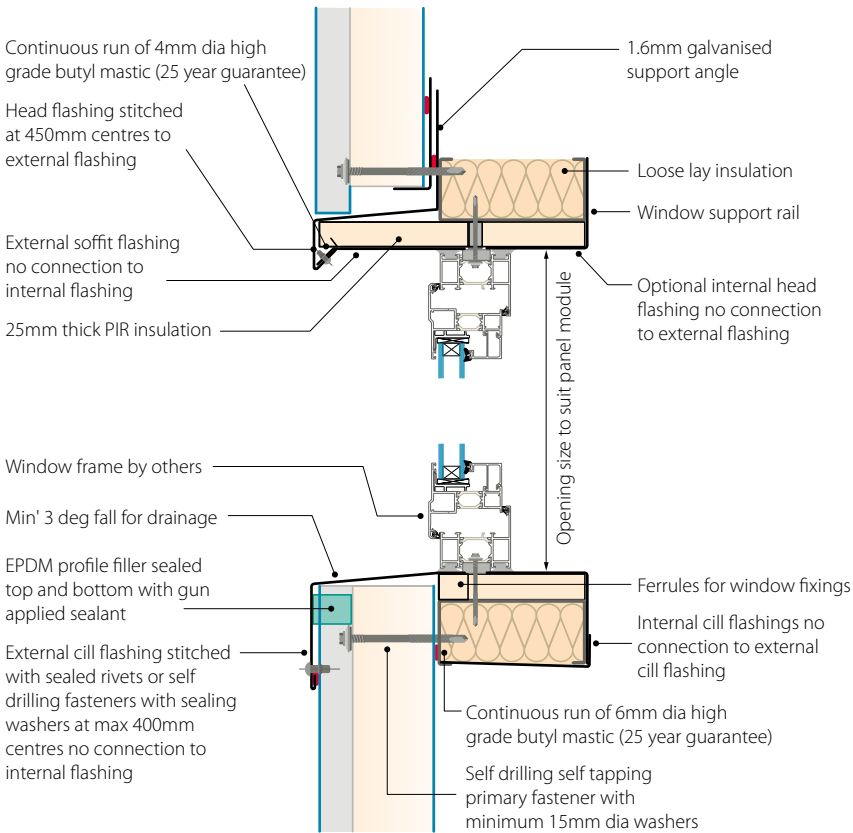

Window/door head

This window flashing detail has been designed so that it can accommodate any proprietary window.

Psi value (W/mK)	f factor
0.614	0.735

Stated calculation results are dependant on components being as shown. Computer modelled in accordance with EN ISO 10211.

Window sill

Psi value (W/mK)	f factor
0.613	0.878

Stated calculation results are dependant on components being as shown. Computer modelled in accordance with EN ISO 10211.

Window/door jamb

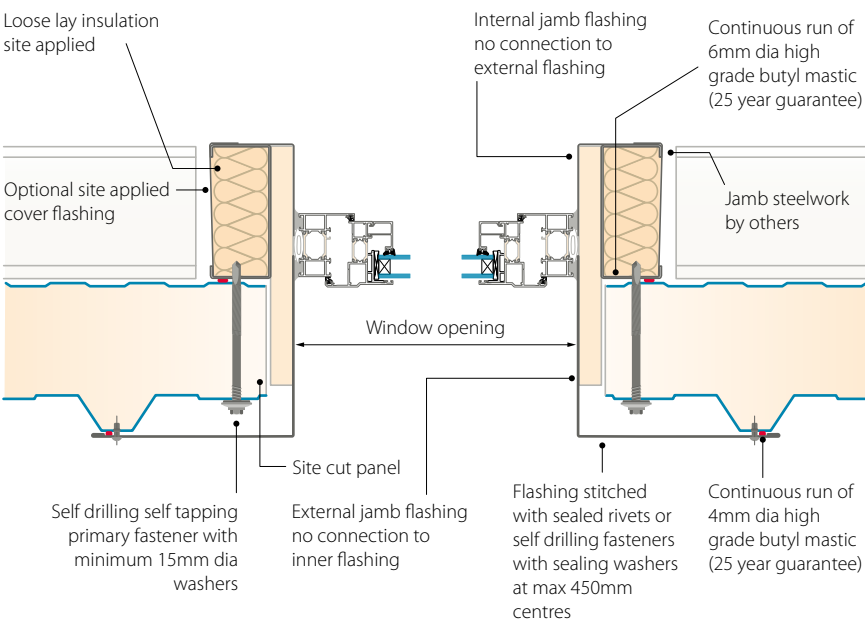

Window/door jamb

Trimming steel work around the opening is required to support the window or door independent to the panels.

Construction details – wall continued

Penetration options, small

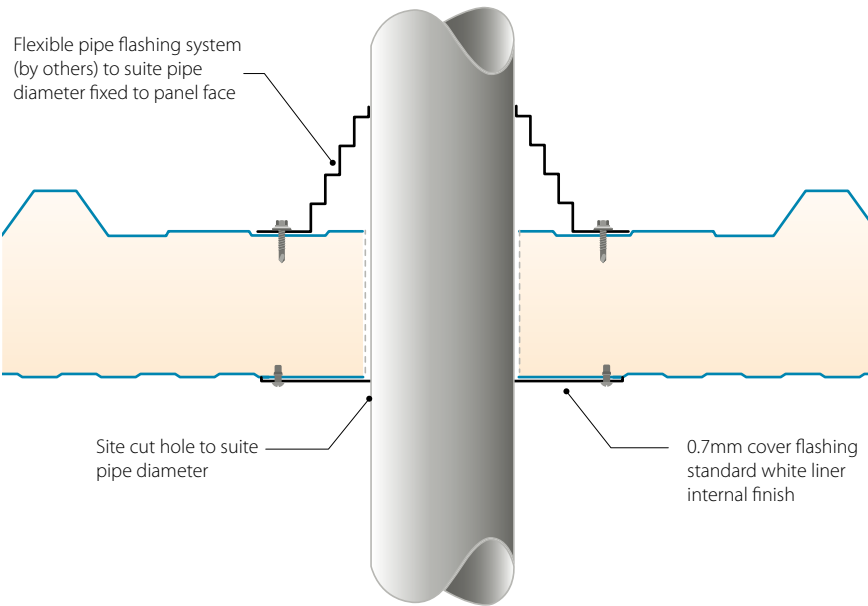

Penetration options, small and small hot

The pipe flashings are available in various specifications to facilitate different opening sizes and temperature ranges. Further details on these specifications and for order placement please contact our Platinum® System Guarantee approved suppliers, who are:

SFS intec Ltd, T: +44 (0) 113 2085 500,
EJOT UK, T: +44 (0) 1977 687040 or
Ash & Lacy Building Systems
T: +44 (0) 121 525 1444.

Penetration options, small hot

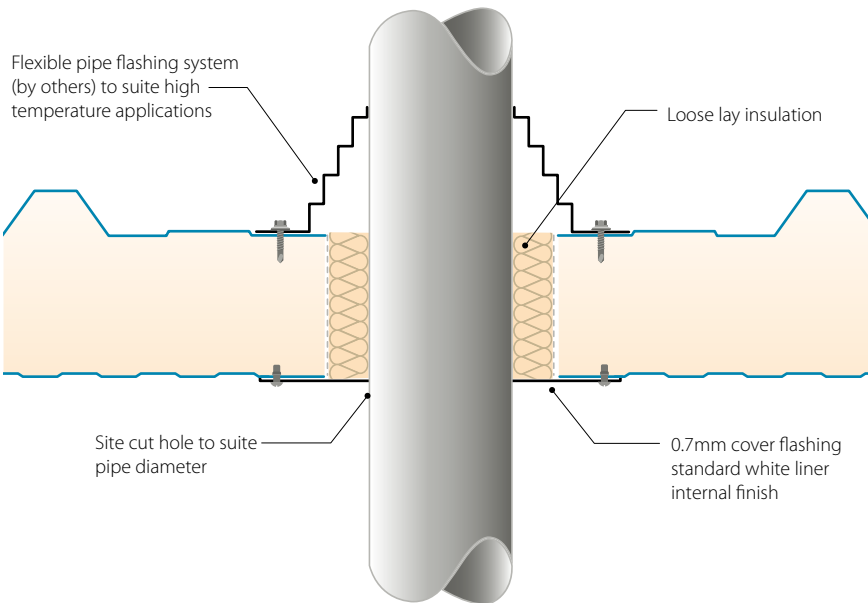

Vertical to horizontal break

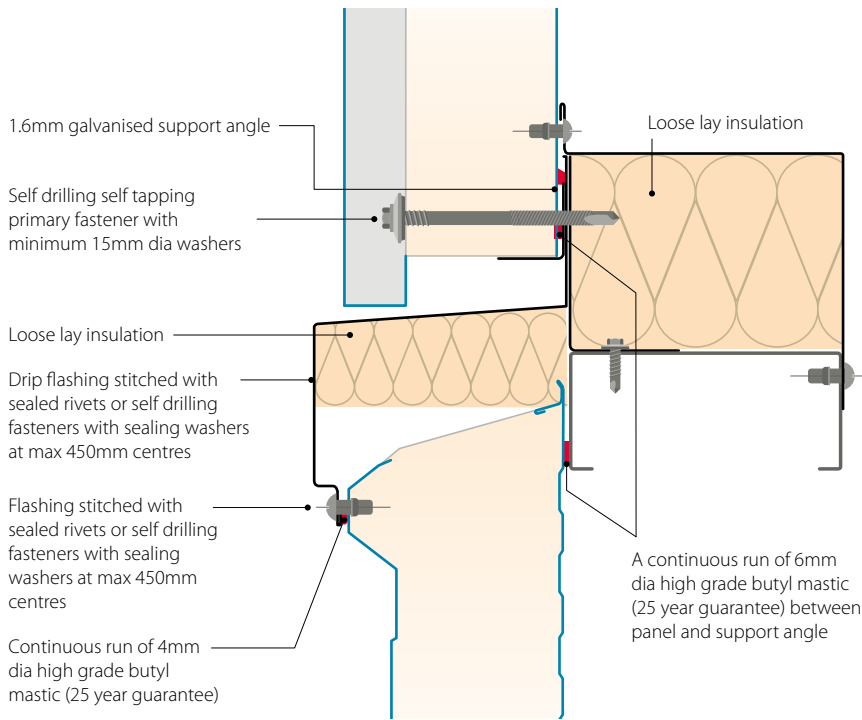

Vertical to horizontal break
Horizontal and vertical panels can be installed adjacent to each other creating interesting architectural features, while the drip flashing detail still maintains thermal performance and an efficient weather seal.

Psi value (W/mK)	f factor
1.103	0.579

Stated calculation results are dependant on components being as shown. Computer modelled in accordance with EN ISO 10211.

Brick wall abutment

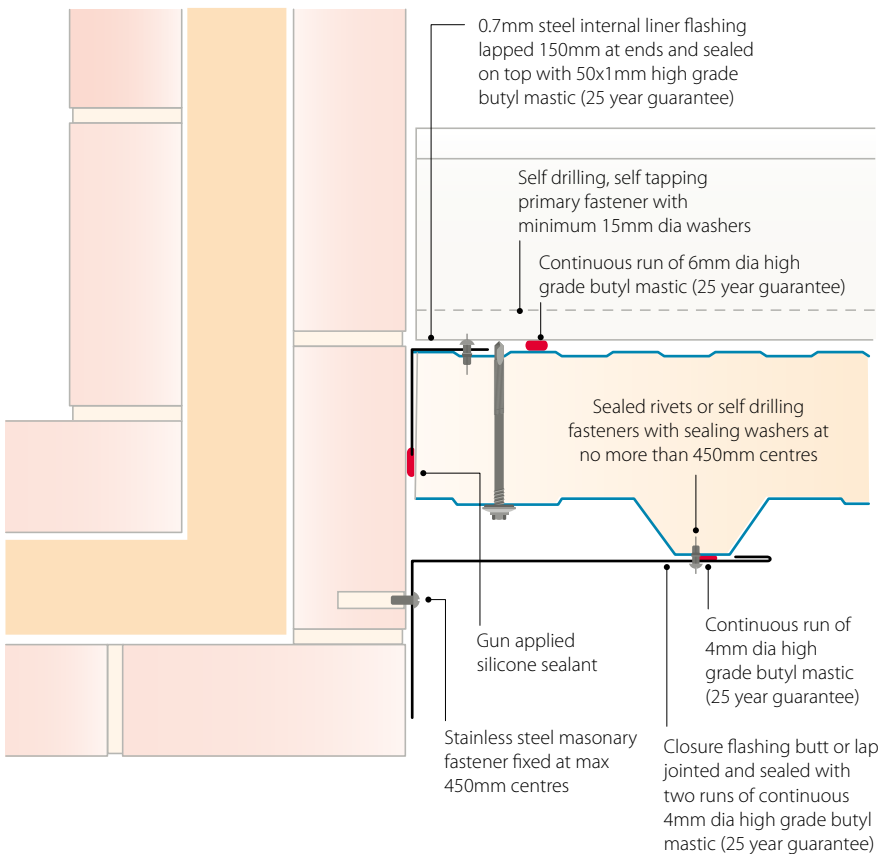

Brick wall abutment
Masonry fasteners to be stainless steel to maintain the durability of the system.

Psi value (W/mK)	f factor
0.260	0.837

Stated calculation results are dependant on components being as shown. Computer modelled in accordance with EN ISO 10211.

Construction details – wall continued

Horizontal details

Side lap

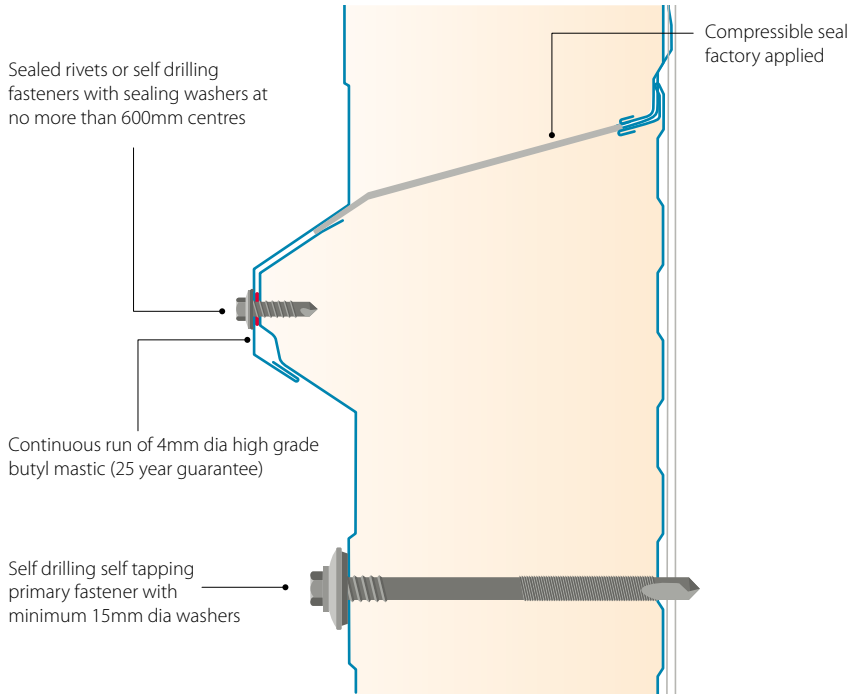

Side lap

The new side lap joint design enables panels to be lapped simply providing fast and efficient installation.

End lap

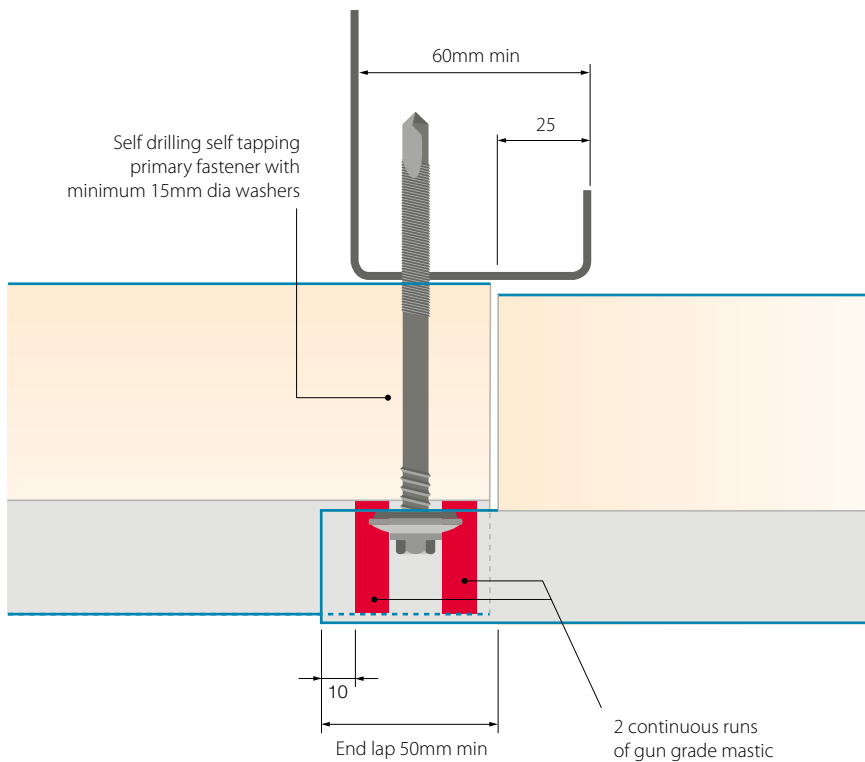

End lap

Gun grade silicon sealant is used in the end laps to ensure the outer profiles nestle closely for improved aesthetics.

Slab base drip

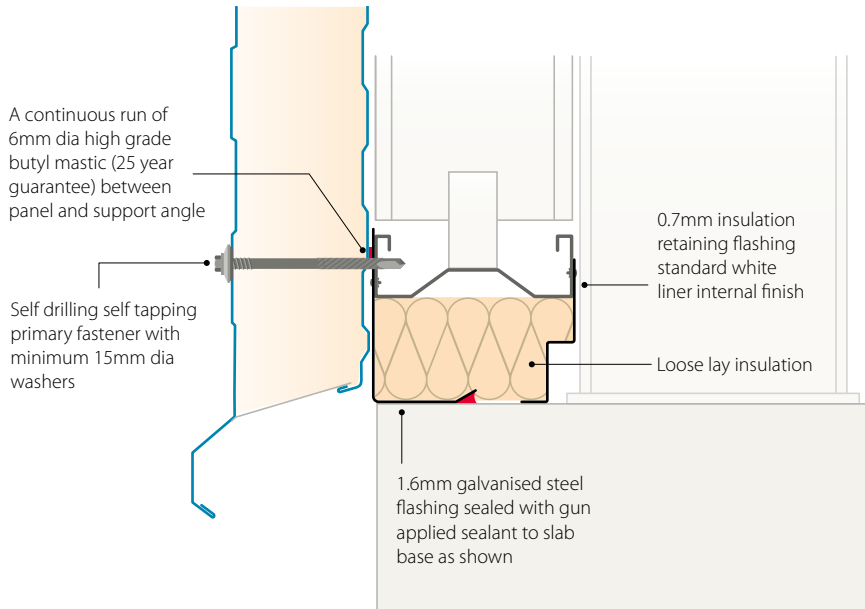

Expansion joint

The 'V' formed flashing allows movement at this junction.

Psi value (W/mK)	f factor
0.024	0.972

Stated calculation results are dependant on components being as shown. Computer modelled in accordance with EN ISO 10211.

Dado wall drip

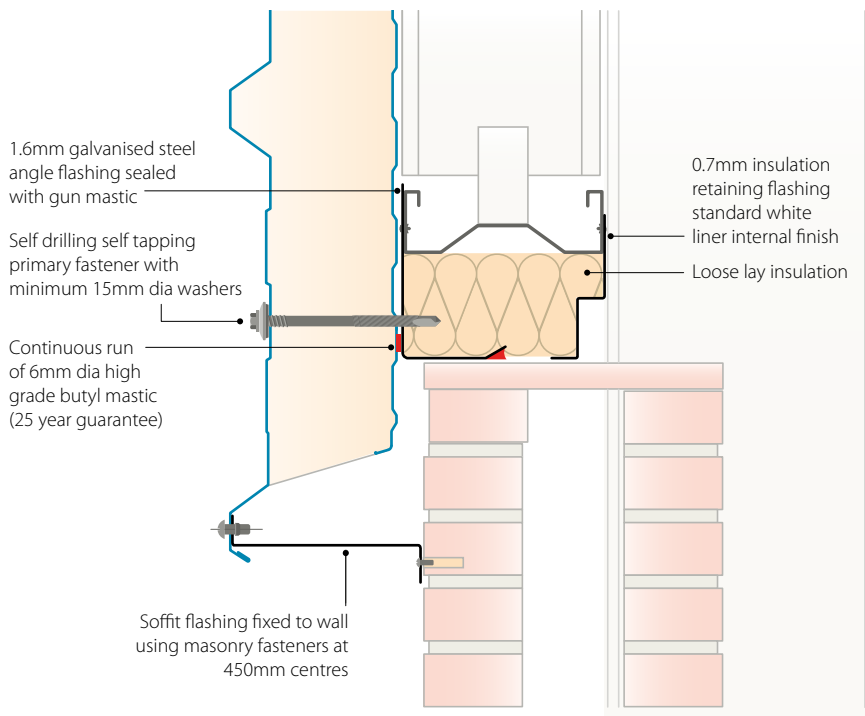

Dado wall drip

The 1.6mm galvanised steel support flashings should be fixed together prior to placement and securing to wall capping and bottom rail.

Psi value (W/mK)	f factor
0.484	0.702

Stated calculation results are dependant on components being as shown. Computer modelled in accordance with EN ISO 10211.

Construction details – wall continued

External corner

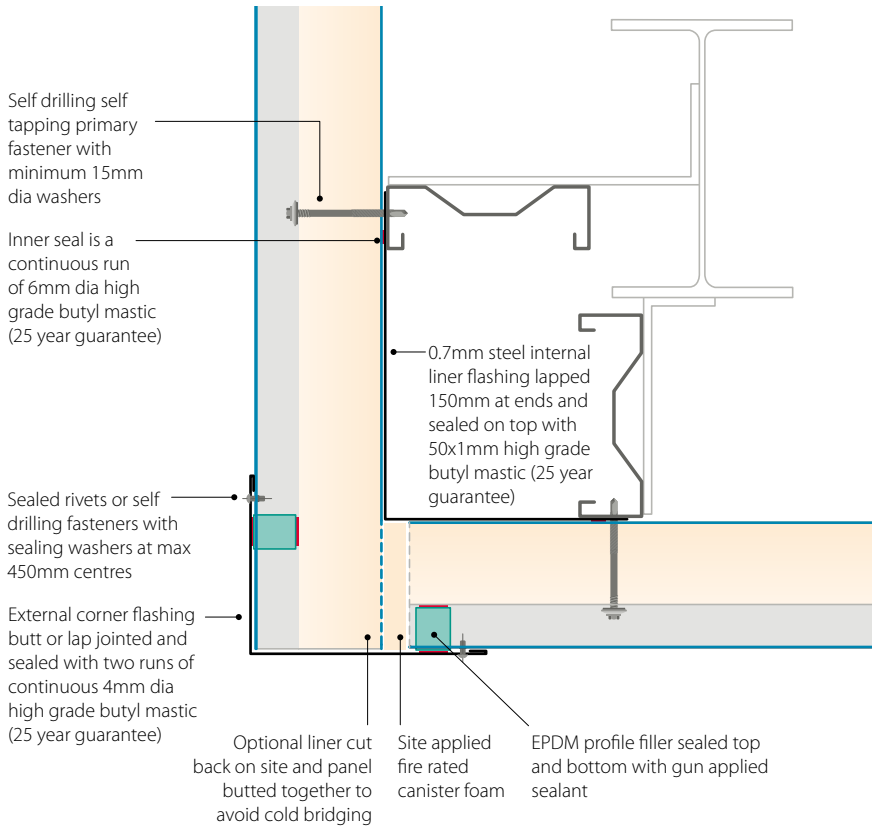

External corner

Thermal performance can be enhanced by the on site removal of the panel liner, within the corner junction, therefore reducing the risk of cold bridging. Running a circular saw to a depth of 15mm at approximately 100mm from the panel edge and then peeling the cut strip of steel away can easily remove the liner.

Psi value (W/mK)	f factor
With liner cut back	
0.041	0.957
Without liner cut back	
0.092	0.939

Stated calculation results are dependant on components being as shown. Computer modelled in accordance with EN ISO 10211.

Internal corner

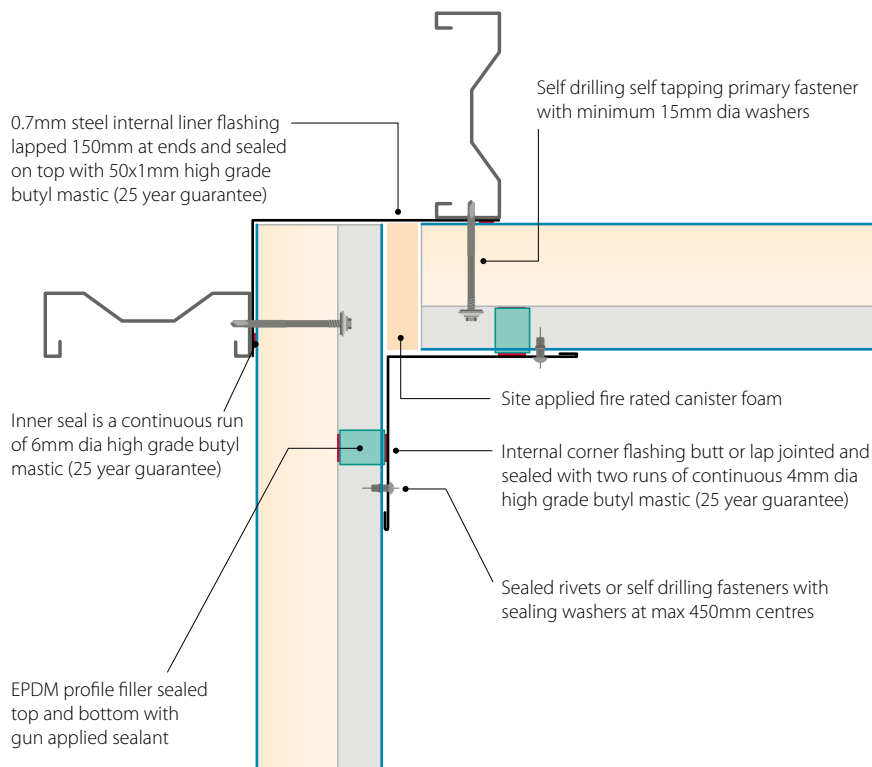

Internal corner

Before fillers and outer flashing are applied, fire rated canister foam should be applied into the void between the panel end and the trough of the adjacent panel.

Psi value (W/mK)	f factor
With liner cut back	
0.019	0.940
Without liner cut back	
0.092	0.939

Stated calculation results are dependant on components being as shown. Computer modelled in accordance with EN ISO 10211.

Window/door head

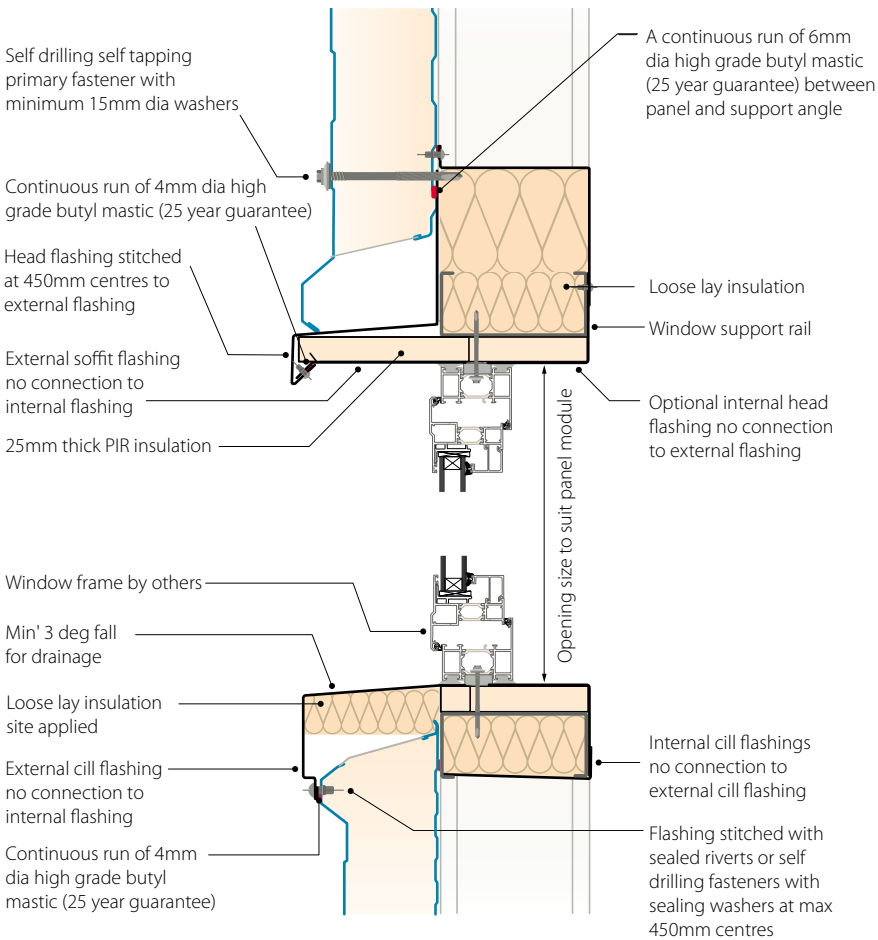

Window/door head

This window flashing detail has been designed so that it can accommodate any proprietary window.

Psi value (W/mK)	f factor
0.614	0.735

Stated calculation results are dependant on components being as shown. Computer modelled in accordance with EN ISO 10211.

Window sill

Psi value (W/mK)	f factor
0.613	0.878

Stated calculation results are dependant on components being as shown. Computer modelled in accordance with EN ISO 10211.

Window/door jamb

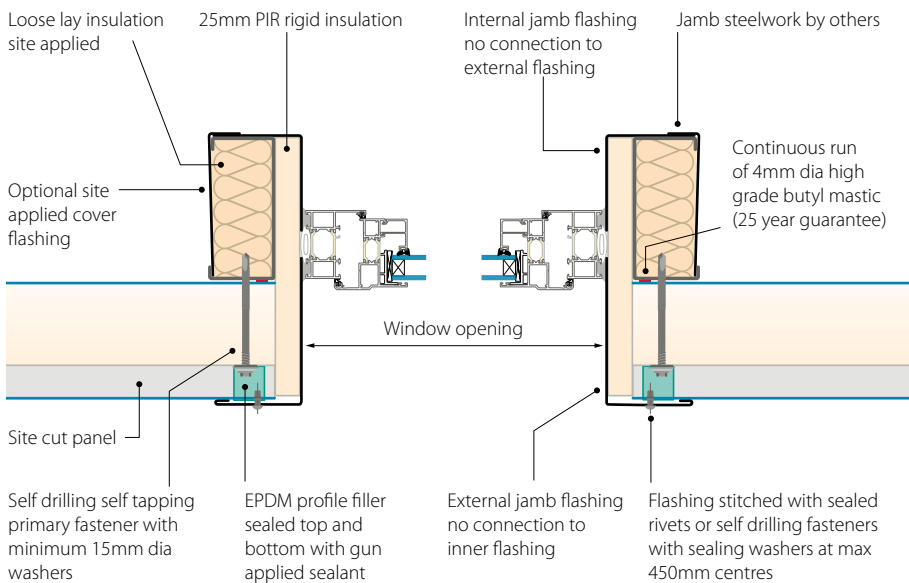

Window/door jamb

Trimming steel work around the opening is required to support the window or door independent to the panels.

Construction details – wall continued

Horizontal to vertical break

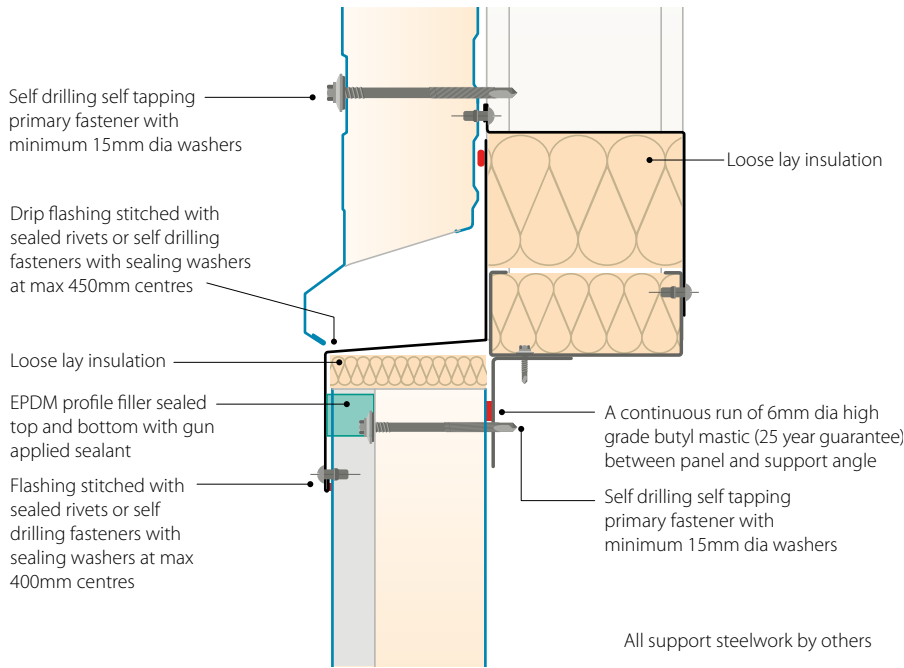

Horizontal to vertical break

Horizontal and vertical panels can be installed adjacent to each other creating interesting architectural features, while the drip flashing detail still maintains thermal performance and an efficient weather seal.

Psi value (W/mK)	f factor
1.103	0.579

Stated calculation results are dependant on components being as shown. Computer modelled in accordance with EN ISO 10211.

Brick wall abutment

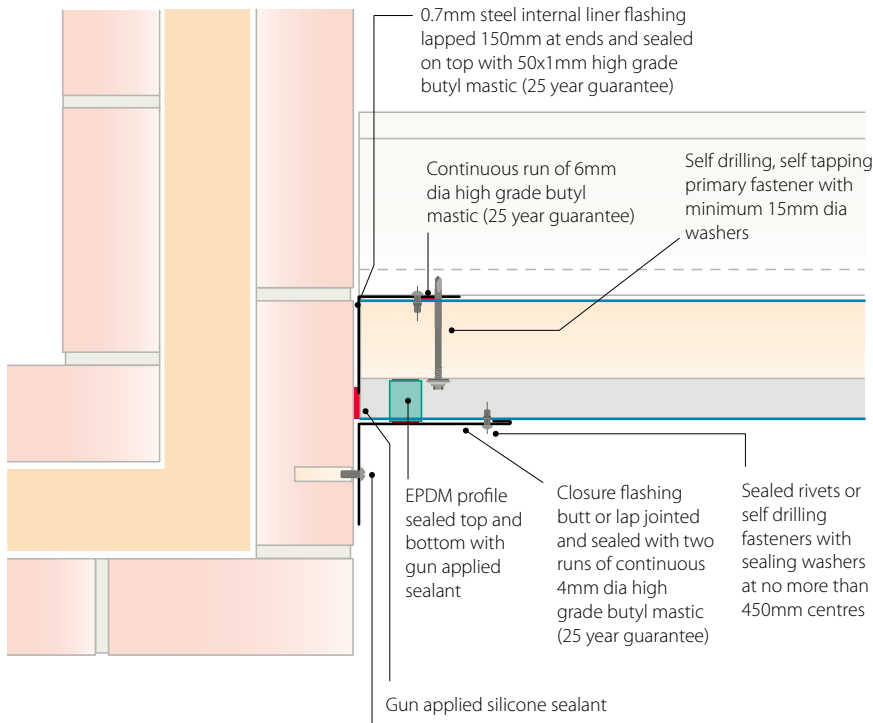

Brick wall abutment

Masonry fasteners to be stainless steel to maintain the durability of the system.

Psi value (W/mK)	f factor
0.260	0.837

Stated calculation results are dependant on components being as shown. Computer modelled in accordance with EN ISO 10211.

Fasteners, sealants and fillers

Fastener selection table

Primary fixing for Trisomet® 333 System (3-Rib) to steel purlins

Application	Panel core thickness (mm)	SFS intec Ltd	EJOT UK	Ash & Lacy
Cold-rolled purlins, 1.2–3 mm	40	SXCP5-S15-5,5 x 82+ COLOUR	CF15 JT3-D6H 5.5/6.3 x 67+ COLOUR	BM-CPLS082-S16-COLOUR
	60	SXCP5-S15-5,5 x 92+ COLOUR	CF15 JT3-D6H 5.5/6.3 x 107+ COLOUR	BM-CPLS100-S16-COLOUR
	80	SXCP5-S15-5,5 x 113+ COLOUR	CF15 JT3-D6H 5.5/6.3 x 127+ COLOUR	BM-CPLS115-S16-COLOUR
	100	SXCP5-S15-5,5 x 133+ COLOUR	CF15 JT3-D6H 5.5/6.3 x 147+ COLOUR	BM-CPLS135-S16-COLOUR
	120	SXCP5-S15-5,5 x 163+ COLOUR	CF15 JT3-D6H 5.5/6.3 x 167+ COLOUR	BM-CPLS150-S16-COLOUR
Hot-rolled purlins, 4–14 mm	40	SXCP14-S15-5,5 x 80+ COLOUR	CF15 JT3-D12H 5.5/6.3 x 75+ COLOUR	BM-CPHS080-S16-COLOUR
	60	SXCP14-S15-5,5 x 99+ COLOUR	CF15 JT3-D12H 5.5/6.3 x 95+ COLOUR	BM-CPHS105-S16-COLOUR
	80	SXCP14-S15-5,5 x 118+ COLOUR	CF15 JT3-D12H 5.5/6.3 x 115+ COLOUR	BM-CPHS125-S16-COLOUR
	100	SXCP14-S15-5,5 x 134+ COLOUR	CF15 JT3-D12H 5.5/6.3 x 155+ COLOUR	BM-CPHS150-S16-COLOUR
Side-lap stitcher	All	SLP2-S-S14-4,8 x 20+ COLOUR	CF15 JT3-2-6.3 x 25+ COLOUR	BM-ST22 or 27-S16-COLOUR
Metal flashings to panel	All	SLP2-S-S14-4,8 x 20+ COLOUR	CF15 JH3-2-6.3 x 25+ COLOUR	BM-ST22 or 27-S16-COLOUR

When fixing to timber, fastener pullout values may limit the ability of the roof to resist wind uplift loads. If in doubt, consult the Technical Department 0845 30 88 330.

All fasteners can be sourced from: SFS intec Ltd, T: +44 (0) 113 2085 500, EJOT UK Limited, T: +44 (0) 1977 687040 or Ash & Lacy Building Systems, T: +44 (0) 121 525 1444

Fasteners

The primary fasteners for securing the Trisomet® 333 System wall panel to structural steel rails have been purpose designed to facilitate speed of fixing give structural security with reduced risk of over compression and have minimal thermal bridging. Time-consuming predrilling of the panel or purlin is not necessary, as the high-thread fastener self drills: the lower thread taps into the purlin and the higher thread taps into the outer skin, thereby clamping the panel securely in a single operation.

Side lap stitching, should be at maximum of 600mm. The stitcher can either be a painted sealed rivet or integral nylon colour headed austenitic stainless steel self-drilling fastener.

When a flashing needs to be secured to the panel, side lap fasteners can be used.

Standard fastener layout at all rail positions

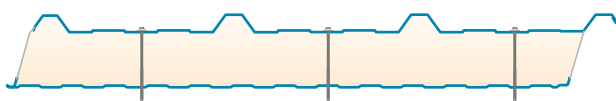

Sealants and fillers

The end lap of the Trisomet® 333 System requires two rows of 6x5mm high grade butyl mastic (25 year guarantee) for vertical or gun grade silicon for horizontal applications.

The 6x5mm mastic this generally comes in rolls of 9.6m with 30 rolls per box and the gun grade silicon standard tube would cover approximately 4.5m of end lap.

Position the sealant in straight, unbroken lines, following the profile, taking care to avoid any stretch. Ensure the continuity and the effectiveness of the seal, especially at corners of sheets. The two lines of strip sealant must be placed 10mm from the sheet ends at the top and bottom of the lap.

The side lap of the panel is sealed with the 4mm diameter high grade butyl mastic (25 year guarantee) run continuously to weather side of the stitching fastener.

For panel ends at ridges and hips, black EPDM large flute profile fillers should be located between the panel's external skin and the cover flashing to provide continuity of weather seal and to prevent access by insects and small birds. These fillers should be sealed to top and bottom with gun applied solvent release bedding sealant.

All sealants and fillers can be sourced from either: SFS intec Ltd, T: +44 (0) 113 2085 500, EJOT UK Ltd, T: +44 (0) 1977 687040 or Ash & Lacy Building Systems, T: +44 (0) 121 525 1444.

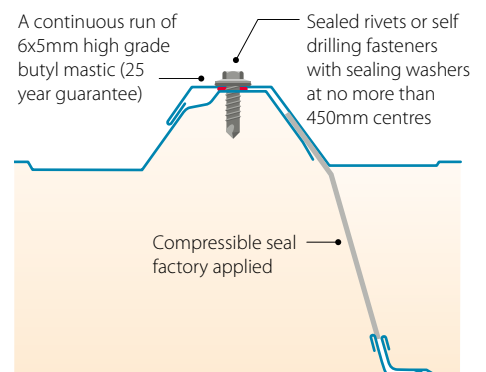

Wall installation

Installation: Wall panel

The steps given below are instructions for a typical construction and should be used only as a guide. Specific technical details, method statements and site-specific risk assessments should be produced and applied for each building. An extended list of construction details is available from Tata Steel, and advice can be given via our technical department on any bespoke details that may be required.

The following steps apply to a wall made up of multiple panels with one end lap joint. Wherever practical, panels of the same length from base level to eaves should be used to avoid end laps. This provides a cleaner finish and a more economical installation.

Vertical wall installation

1. Checks should be carried out to make sure that the bottom rail is adequately supported and level along its full length before commencing installation work.
2. Carry out preparation work on sill trims and the base support angle for the first panel, and ensure these are lined, levelled and sealed as specified (see page 36 of construction details).
3. Hoist the first panel and position on the support angle with the overlap edge adjacent to the corner. Before inserting the fasteners, ensure that:
 - a. The setting out dimensions are observed. Failure to comply with these dimensions may lead to problems later in the section.
 - b. The panel is plumb using a plumb line.
- c. The position of the panel relative to the bottom and top or intermediate rails is correct. Check this with the erection drawings.
4. Fix the panel using primary fasteners as specified. Make sure the fasteners are not over tightened, and clean away drilling swarf to avoid rust marks.
5. Ensure that the top of the lower panel (i.e. panel 1) is clean and dry, and then apply the two rows of sealant across the panel width in positions as shown. The first seal should be placed above the fixing line, the second between 10mm from the end of the specified lap (100mm recommended). The seal should be carefully applied to ensure coverage in the corners of the profile.

First panel laid

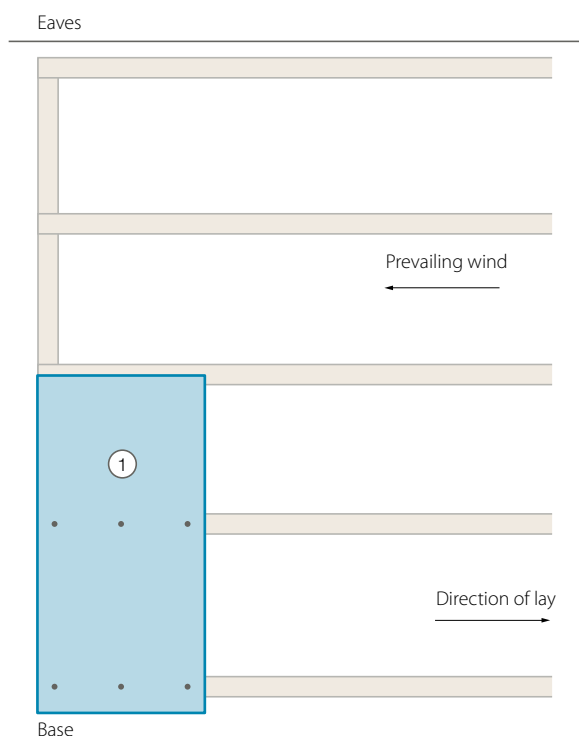

Second panel laid

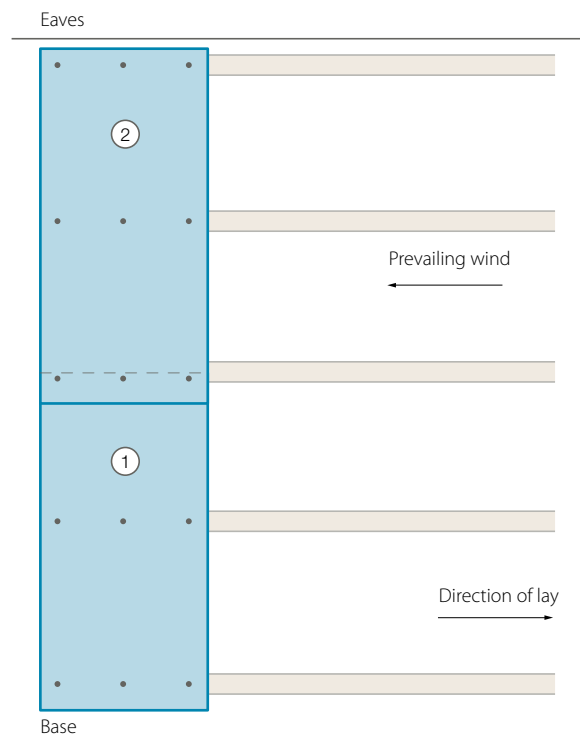

End lap with three rows of sealant

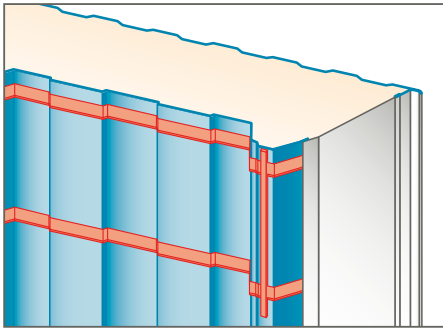

6. Ensure the cutback of panel 2 is clean and dry before positioning the panel over panel 1, as shown. Be careful not to disturb the seals. Align the profiles of the two panels before securing.
7. Run the side lap seal continuously from eaves to base ensuring this is placed to the weather side of the side lap. Side lap panel 3 and secure with specified number of fasteners.
8. Apply the end-lap seals to panel 3 as shown.
9. Ensure that the cutback of panel 4 is clean and dry. Position the end of panel 4 over panel 3 and side lap as before. Ensure that the profiles of the two panels are aligned before securing into the rails. Secure the side lap using sealed rivets or stitching screws at a minimum of 600mm centres.
10. Continue steps 5 to 9 until the elevation is complete. Fit the external flashings and ensure they are sealed as specified.

Side lap

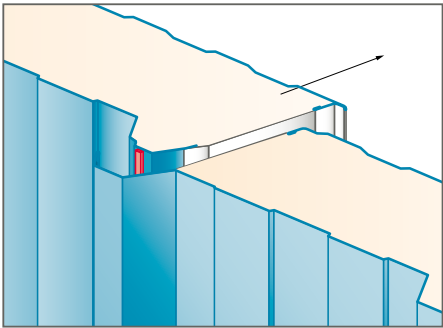

Third panel laid

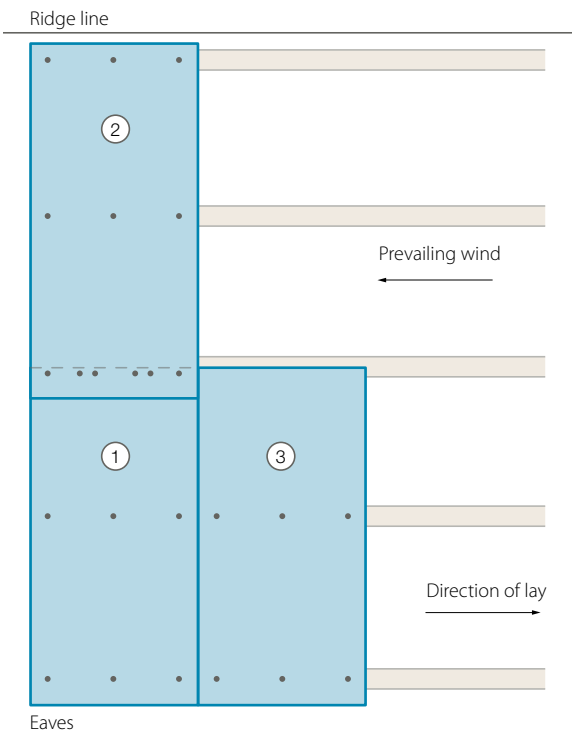

Fourth panel laid

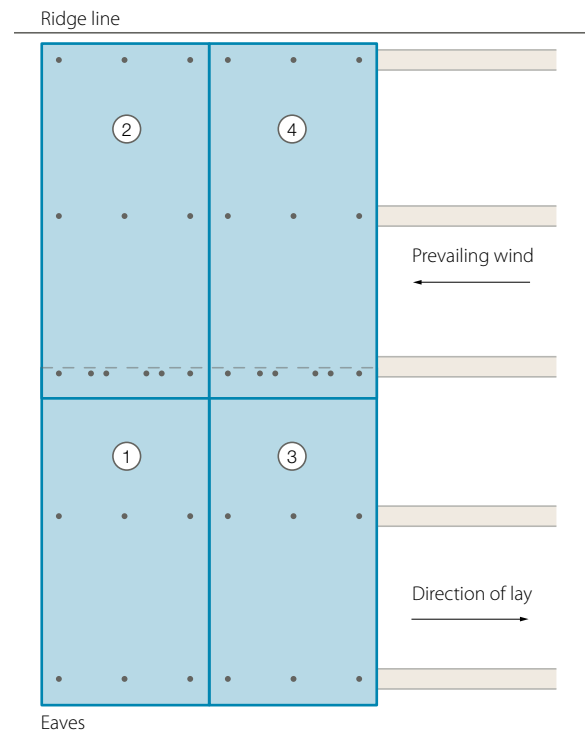

Wall installation continued

Horizontal wall installation

The following steps apply to a wall made up of multiple panels with one end lap joint between the corners of the elevation. For elevations containing more than one end lap ensure that each horizontal level of panels is complete before starting the row above.

When running panels horizontally on a wall elevation, care must be taken when ordering the handing of the product. The standard vertically laid left-to-right handed panels will run right-to-left when installed horizontally as shown below.

1. Carry out preparation work on sill trims. Ensure that these are lined, levelled and sealed as specified (see page 45 of construction details).
2. Temporarily support base panel and secure with one fastener. Recheck level and the bearing dimensions, on vertical supports, are correct before fully securing with specified number of fasteners. Ensure the fasteners are not over tightened, and clean drilling swarf from the rib ledge to avoid rust marks.
3. Ensuring that the end of the first panel is clean and dry, apply two rows of gun-grade silicone sealant across the full width of the panel in positions as shown. The first seal should be placed behind the fixing line, and the second 10mm from the end of the specified lap (50mm recommended).

End lap with two rows of sealant

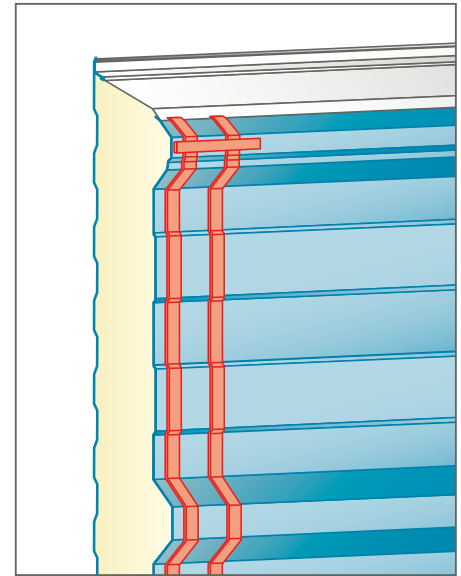

First and second panel laid – Vertical wall

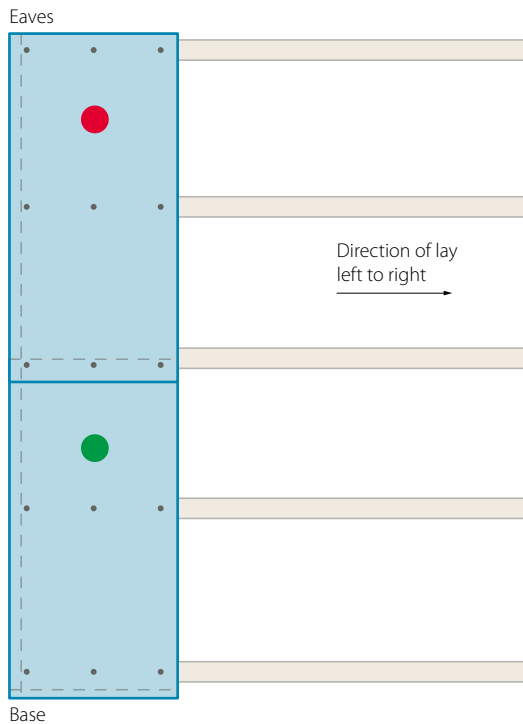

NB. Care must be taken when ordering product handing for horizontal wall installations.

First and second panel laid – Horizontal wall

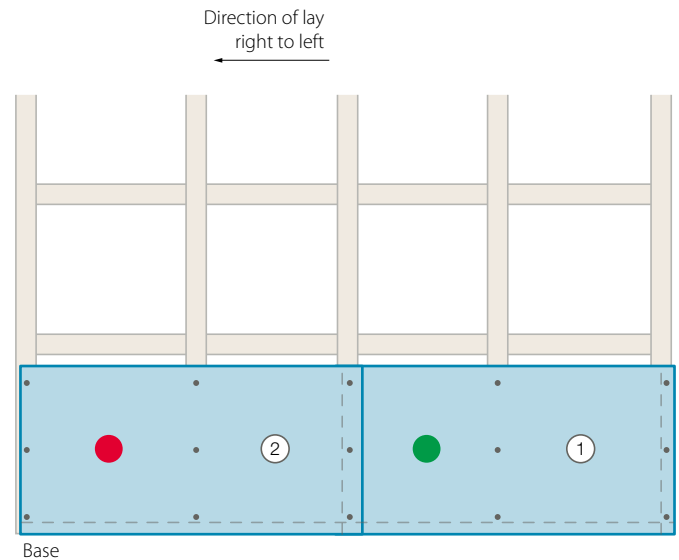

4. Ensure the cutback of panel 2 is clean and dry before positioning the panel over panel 1. Ensure that the profiles of the two panels are aligned before securing them to the vertical cladding rails using the recommended number of fasteners.
5. Run the side lap seal continuously to the bottom row of panels ensuring this is placed to the weather side of the side lap. Side lap panel 3 and secure with specified number of fasteners.
6. Apply the end-lap seals to panel 3 as shown.
7. Ensure that the cutback of panel 4 is clean and dry. Position the end of panel 4 over panel 3 and side lap as before. Ensure that the profiles of the two panels are aligned before securing into the rails. Secure the side lap using sealed rivets or stitching screws at a minimum of 600mm centres.
8. This procedure should be continued along the full width of the elevation before starting the second row of panels. Continue row by row until the elevation is complete. Fit the external flashings, and ensure they are sealed as specified.

Side lap

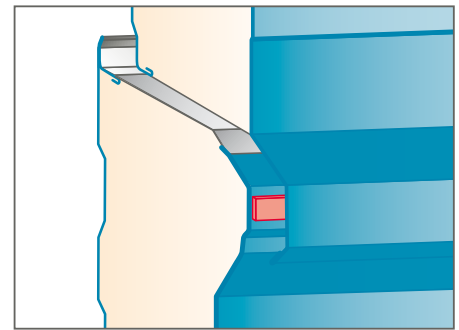

Removal of protective film

Trisomet® 333 System can be supplied with protective film on the external face. This is designed to provide additional protection during manual handling and site fixing. The film has a limited shelf life and must not be exposed to sunlight for long periods because it is susceptible to ultraviolet degradation. This makes the film difficult to remove and may result in adhesive residue that causes dust and dirt to adhere to the decorative finish. To ensure easy, clean removal, remove the film within one month of panel delivery to site.

Third panel laid

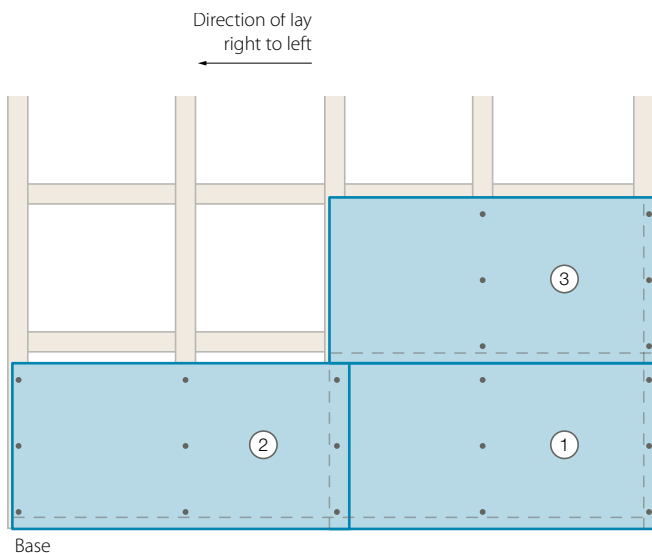

Fourth panel laid

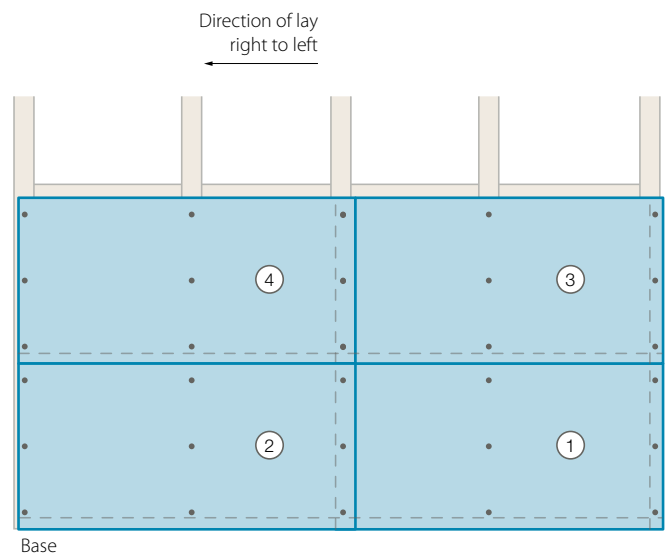

Case Study

Tata Steel Trisomet® 333 System has been specially selected to feature on the new state of the art school in the Eithinog area of Bangor.

This much anticipated £4 million investment by Gwynedd Council will ensure the latest modern 21st century facilities for the pupils and staff of the primary school which will be located near the secondary school, Ysgol Friars in the city.

The school is designed for 210 pupils and is located in an area of ecological importance. Which is why care and precaution has been taken in the design and procurement of the construction materials selected for the new school's building envelope, to ensure it is sympathetic to its surrounding environment. The project has been environmentally assessed by the Building Research Establishment (BRE) and is on course to receive a BREEAM excellent rating.

The building has several renewable features, which include:

- Solar panels to supplement the hot water heating
- Ground source heat pumps to heat the under floor heating
- Photovoltaic panels and wind turbines to supplement the electrical consumption
- Recycled rainwater from the roof to flush the toilets
- Natural daylight and ventilation through large windows
- Wind catchers and Sun pipes to provide natural daylight and ventilation

Rhys Hughes, Ysgol Cae Top Head teacher added: "This new environmentally friendly building gives us a fantastic opportunity to educate the children at Ysgol Cae Top in modern, state-of-the-art facilities that reflect modern educational requirements.

The Trisomet® 333 System which has been used on the roof using Colorcoat Verso® by Tata Steel in Merlin Grey giving the school building a contemporary look as well as the added benefit of blending in to the sky line. Colorcoat Verso® also provides the building improved durability and performance over leathergrain products and is available with a guarantee of up to 30 years.

The Trisomet® 333 System, the latest offering from Tata Steel, is an ideal choice for this project as it offers many sustainability and economic benefits. The system has been specifically engineered by a team of industry experts to perform to the highest standards of thermal performance, air-tightness and structural performance and can be recycled at the end of its life, ensuring one of the most sustainable system for the building envelope.

The quick and easy single component assembly feature of the Trisomet® 333 System is excellent for fast track building. Steve Lester the installer of both systems worked closely with the Architects IPS to select the optimum envelope solution for such a project of this sensitive nature and jointly agreed that Tata Steel fulfilled both their criteria.

Steve Lester, of Lester Fabrications added: "We are familiar with the Systems and I feel confident recommending them due to their quality, design, sustainability credentials and guarantees. One of the greatest advantages of using these systems is that they allow us to finish an installation in half the time required by other systems."

Care has also been taken at every stage of the manufacturing process by Tata Steel to ensure that the carbon footprints of all of their systems are kept to a minimum and this is backed up by Tata Steel to deliver a fully traceable and technically robust solution.

Together with the installation of fire suppression sprinklers to protect the building, the Trisomet® 333 System is also LPCB approved assuring their performance in fire and providing lower insurance premiums.

Tata Steel has established market supremacy in supplying insulated roof and walling systems that allow for flexible design solutions, required to meet the needs of different buildings whilst still being able to create buildings that meet the high levels of air tightness and thermal efficiency demanded by the building regulations.

Client: Development Directorate – School Services

Architect: Gareth Jones – ISP Architects LLP

Contractor: Carillion Building

Installing contractor: Lester Fabrications

Cladding system: Trisomet® 333 System

Colorcoat® product: Colorcoat Verso® in Merlin Grey





Ysgol Cae Top School, Bangor

“We are familiar with the Cladding Systems and I feel confident recommending them due to their quality, design, sustainability credentials and guarantees. One of the greatest advantages of using these systems is that they allow us to finish an installation in half the time required by other systems.”

Steve Lester, Lester Fabrications



www.tatasteelconstruction.com/theworks

Trademarks of Tata Steel UK Limited
(formerly Corus)

Colorcoat, Colorcoat Connection, Colorcoat HPS200, Colorcoat HPS200 Ultra, Confidex, Confidex Sustain, Prisma and Trisomet are registered trademarks of Tata Steel UK Limited.

CarbonNeutral is a registered trademark of the CarbonNeutral Company.

Care has been taken to ensure that the contents of this publication are accurate, but Tata Steel Europe Limited and its subsidiaries, (including Tata Steel UK Limited), do not accept responsibility or liability for errors or information that is found to be misleading. Suggestions for, or descriptions of, the end use or application of products or methods of working are for information only and Tata Steel Europe Limited and its subsidiaries accept no liability in respect thereof.

Before using products or services supplied or manufactured by Tata Steel Europe Limited and its subsidiaries, customers should satisfy themselves as to their suitability.

Printed with biodegradable vegetable inks on material sourced from responsibly managed forests, certified in accordance with the FSC. Contains 10% recovered fibre, diverting waste from landfill.

Copyright 2011 Tata Steel

Tata Steel

Shotton

Deeside

Flintshire

CH5 2NH

T: +44 (0) 845 30 88 330

F: +44 (0) 845 30 11 013

www.tatasteelconstruction.com/theworks

Copyright 2011 Tata Steel UK Limited, Registered Office: 30 Millbank London SW1P 4WY, Registered in England No. 2280000

Language English UK 0411