

©Copyright  
 Prior to commencement of works on the site, the contractor should check all dimensions on the drawings and check against actual site dimensions, and report any discrepancies immediately to the Architect.

Written dimensions are to take precedence over scaled dimensions.

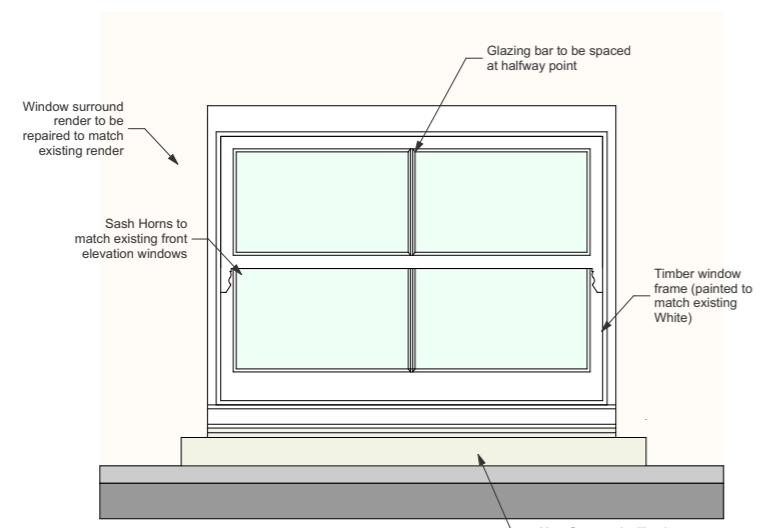

**First Floor Window Elevation**  
 WE-2-03  
 1:20

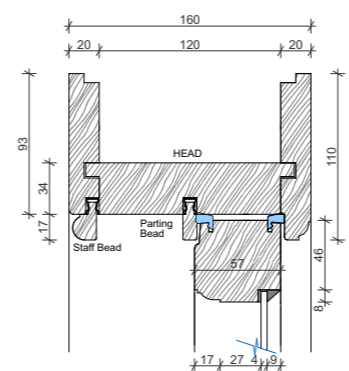

**Window Head Detail**  
 1:5

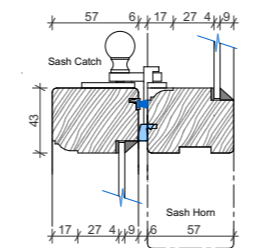

**Window Meeting Rail Detail**  
 1:5

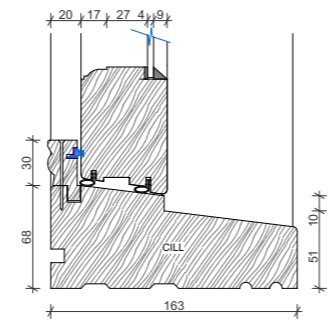

**Window Cill Detail**  
 1:5

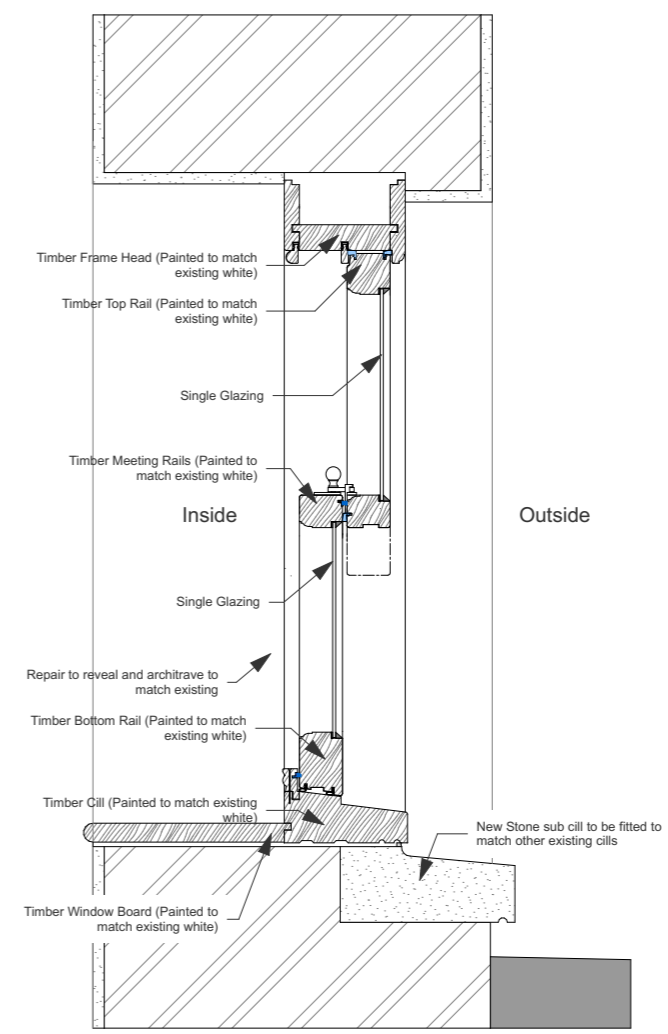

**First Floor Window Section**  
 WE-2-03  
 1:10

Rev	Date	By	Description
03	2020.10.06	FB	Amended to Single Glazing
02	2020.07.20	PT	Drawing renamed
01	2020.02.21	FB	First Issue

**noma architects**  
 14 Guinea Street  
 Redcliffe, Bristol BS1 6SX  
 T 0117 929 2041  
 E mail@noma-uk.com  
 www.noma-uk.com

Job  
**15-16 Brunswick Square, York Street, Bristol**

Client  
**Pirate Studios Ltd**

Drawing Title  
**No. 15 First Floor - New Rear Window WE-2-03 Details**

Drawing Number  
**2139 3406 03**

Project Number Revision  
 2139 3406 03

Tender  
 Purpose of Issue Scale  
**FB PT 2020-02-21 A3**

**2139 Noma 00 00 00 A 00**  
 NOMA Project No Owner Zone Level Type Role Status

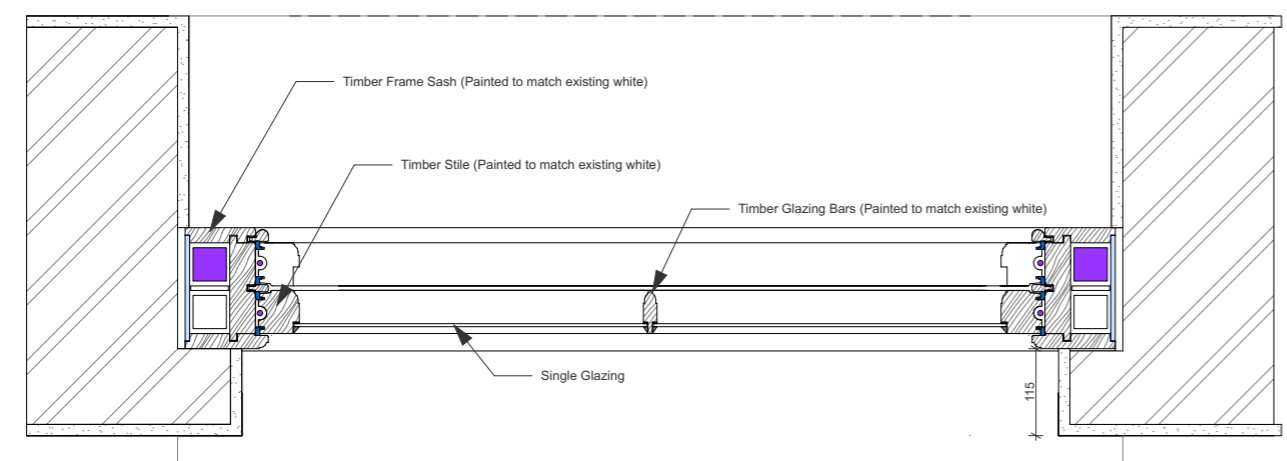

**First Floor Window Plan**  
 WE-2-03  
 1:10

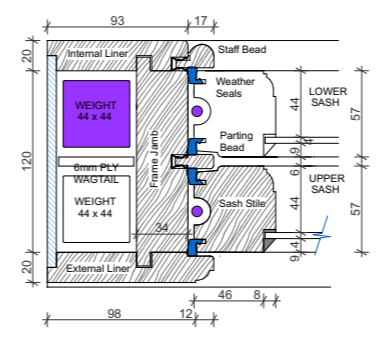

**Window Jamb Detail**  
 1:5

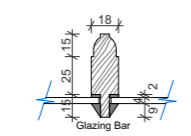

**Window Glazing Bar Detail**  
 1:5