

First Floor Window Elevation
WE-2-02
1:20

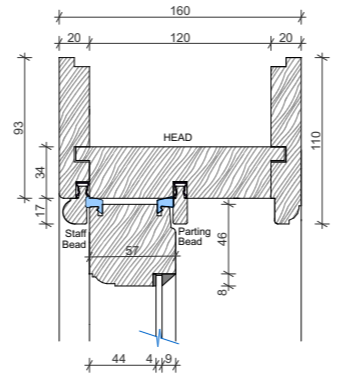

Window Head Detail
1:5

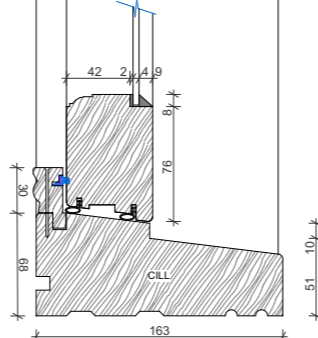

Window Cill Detail
1:5

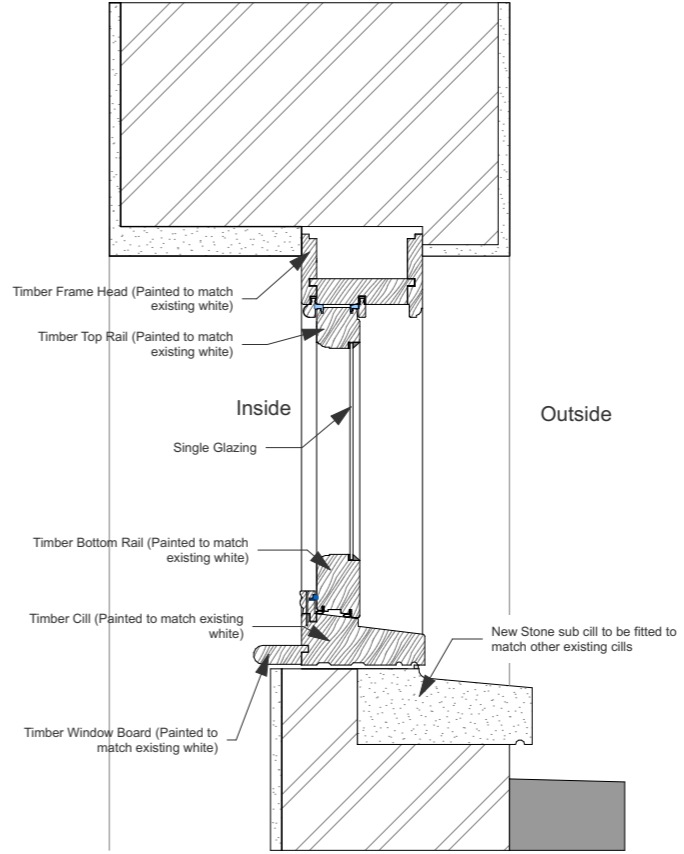

First Floor Window Section
WE-2-02
1:10

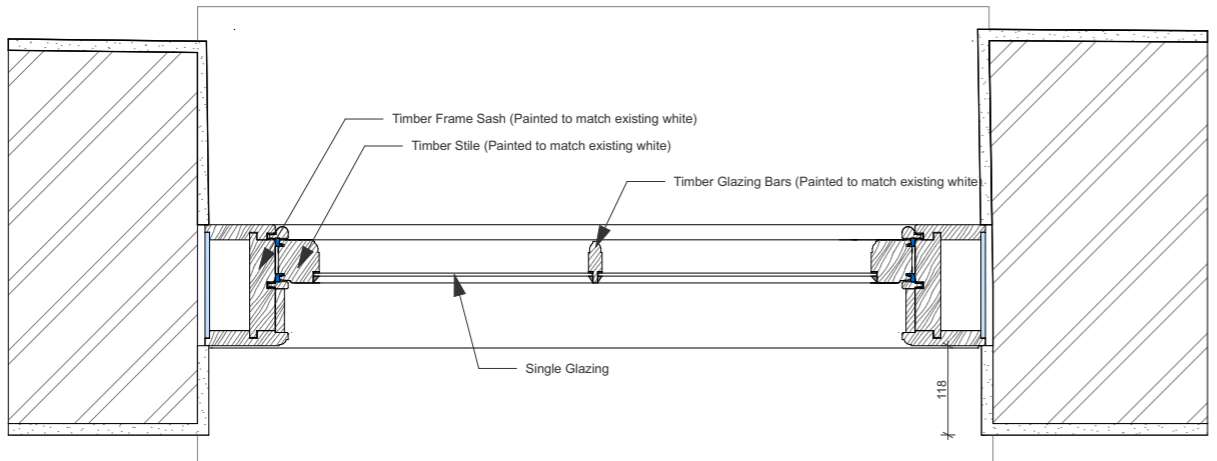

First Floor Window Plan
WE-2-02
1:10

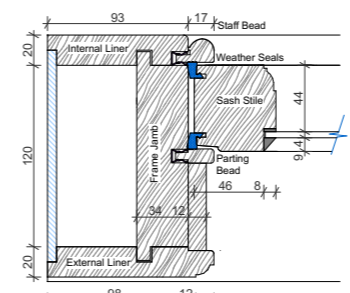

Window Jamb Detail
1:5

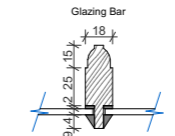

Window Glazing Bar Detail
1:5

©Copyright
Prior to commencement of works on the site, the contractor should check all dimensions on the drawings and check against actual site dimensions, and report any discrepancies immediately to the Architect.

Written dimensions are to take precedence over scaled dimensions.

Rev	Date	By	Description
03	2020.10.06	FB	Amended to Single Glazing
02	2020.07.20	PT	Drawing renamed
01	2020.02.21	FB	First Issue

noma architects
14 Guinea Street
Redcliffe, Bristol BS1 6SX
T 0117 929 2041
E mail@noma-uk.com
www.noma-uk.com

Job
15-16 Brunswick Square, York Street, Bristol

Client
Pirate Studios Ltd

Drawing Title
No. 16 First Floor - New Rear Window WE-2-02 Details

Drawing Number
2139 3405 03

Tender
Purpose of Issue
Scale
1:20, 1:10, 1:5

FB	PT	2020-02-21	A3
Drawn	Checked	Issue Date	Size
2139	Noma	00 00 00	A 00
NOMA Project No	Owner	Zone	Level
		Type	Role
			Status