

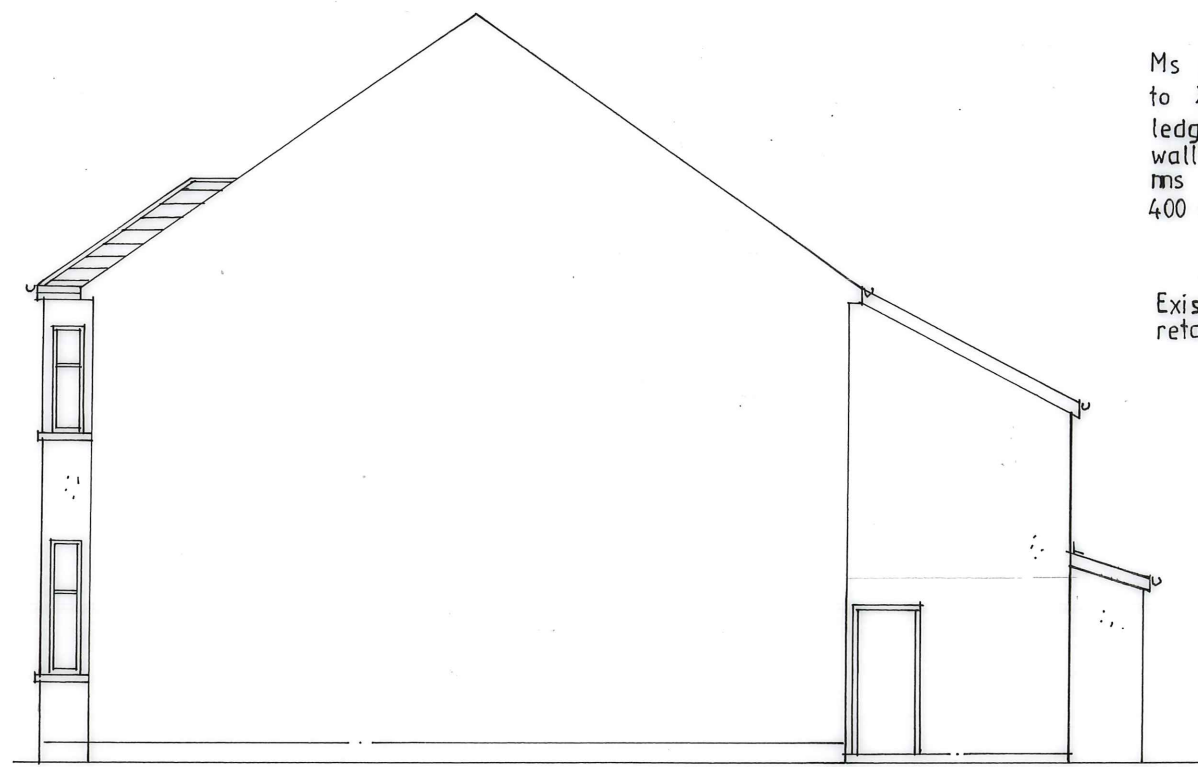

Rear Elevation
as Existing 1/100

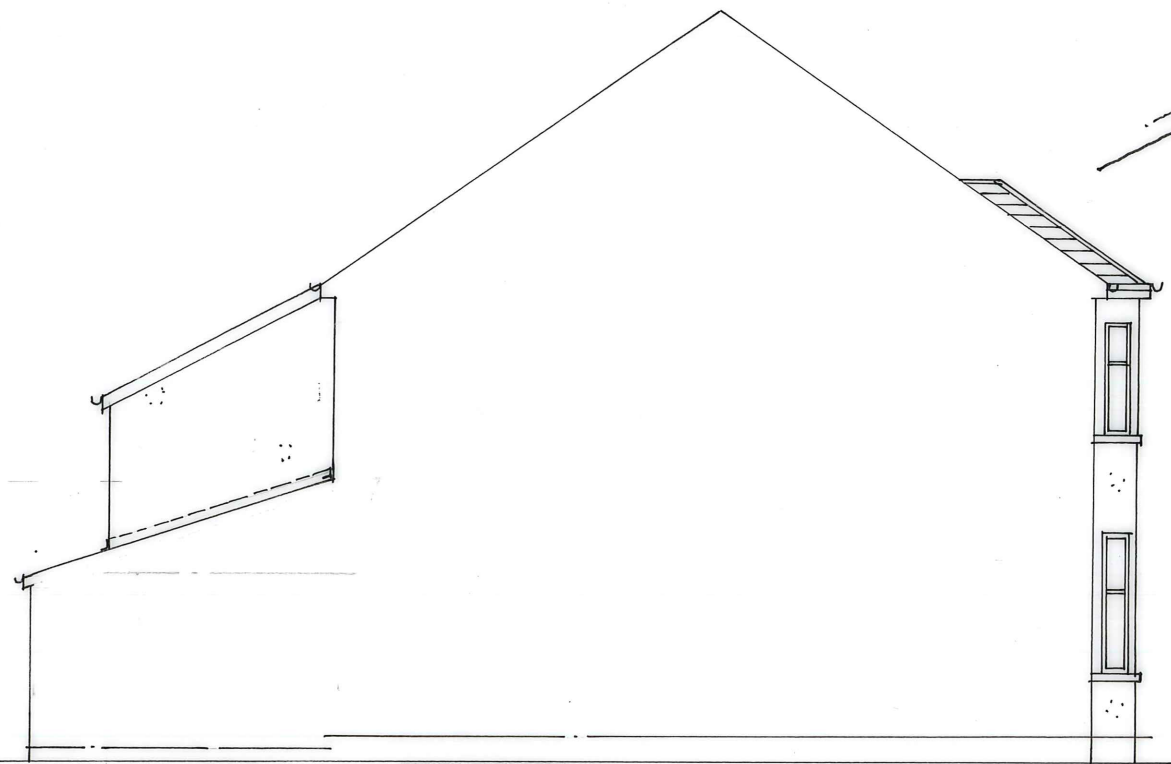

Side Elevation
as Existing

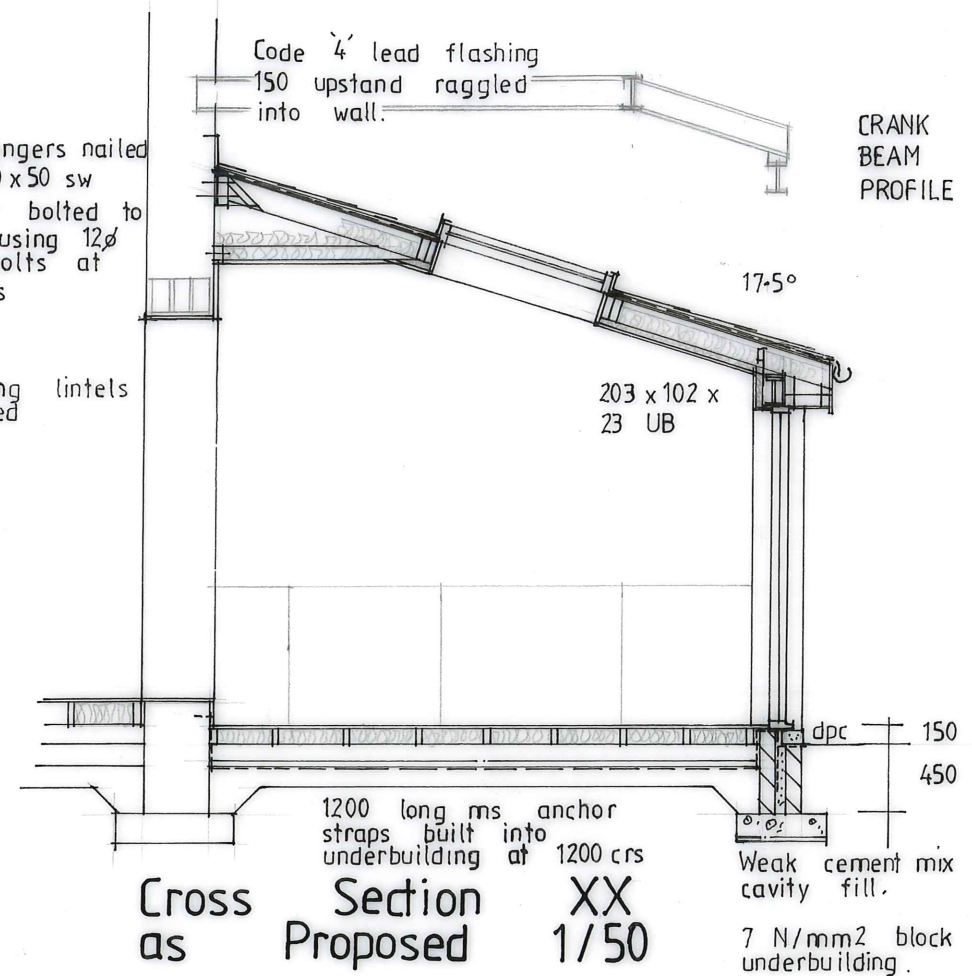

Side Elevation
as Existing

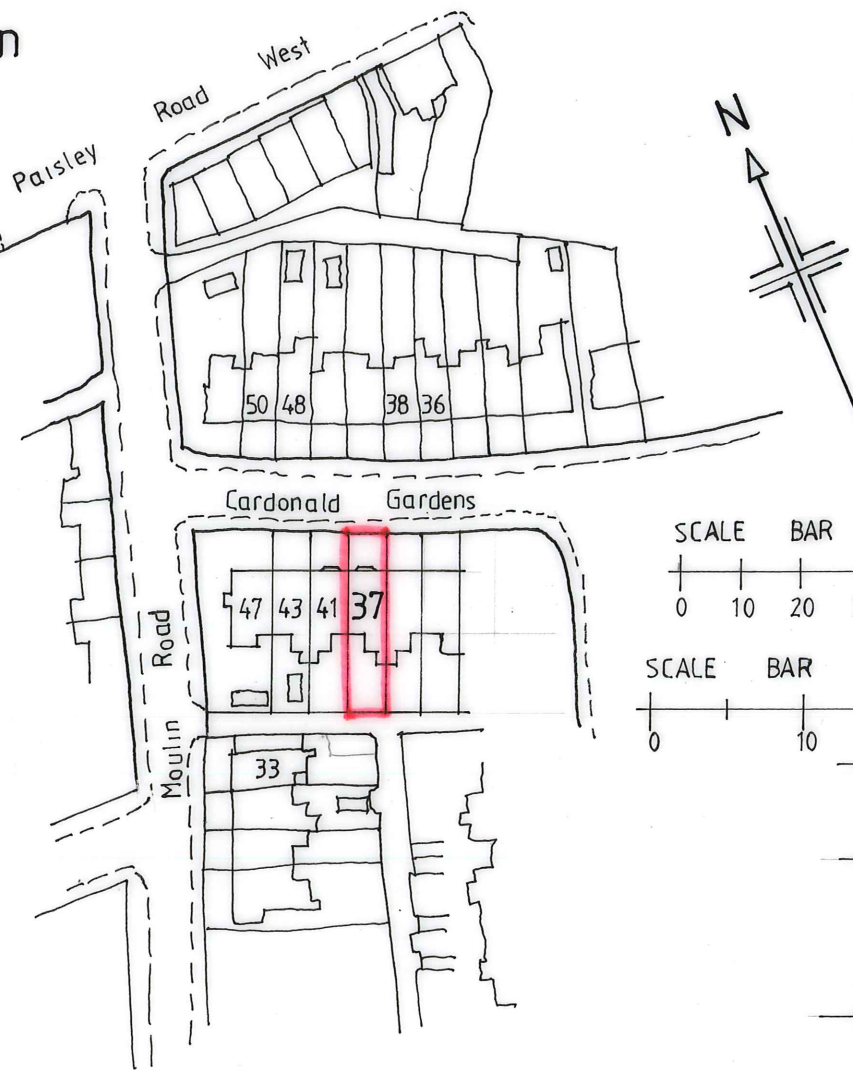

Locality Plan
1/1250

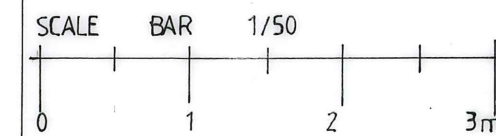
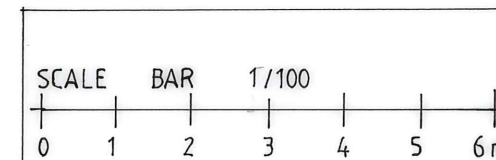
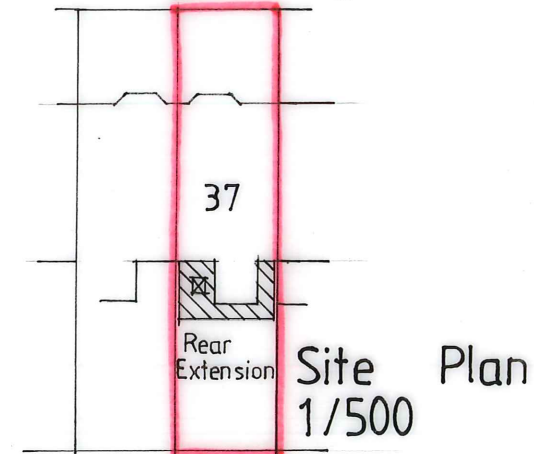
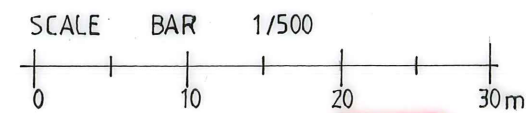
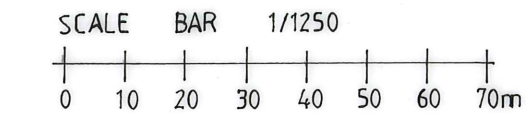

Mr and Mrs McMullan

37 Cardonald Gardens
Cardonald
G52 3PG

Rear Extension and
Internal Alterations
Elevations as Existing

SCALE 1/100 DATE FEB 2021
PAPER SIZE A3 Dwg CSM 2789/2