

Ground Floor Plan

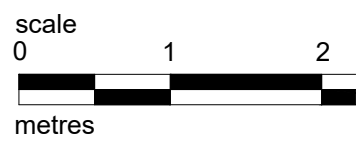
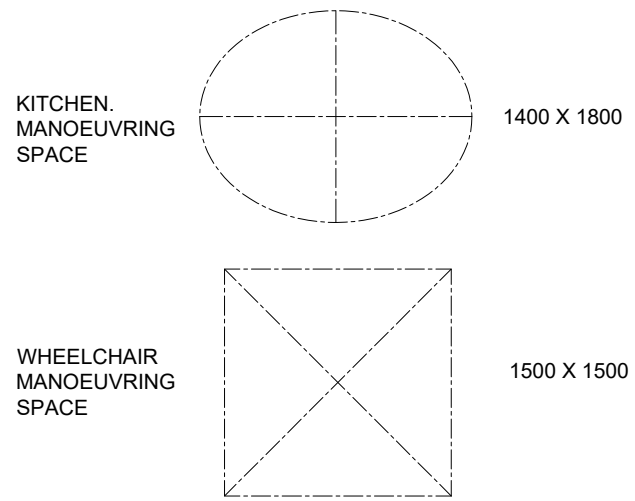

Proposed Extension  
 53 Caldon Road, Irvine.  
 KA12 0RH  
 Access. Manoeuvring and Activity  
 Spaces as Proposed

1:50 scale @A3

Apr 21

