

Guidance Note 01/20

Guidance notes for the reduction of obtrusive light



Copyright © 2020 ILP

All rights reserved. No part of this publication may be reproduced, stored in a retrieval system or transmitted in any form or by any means: electronic, electrostatic, magnetic tape, mechanical, photocopying, recording or otherwise, without permission in writing from the Institution of Lighting Professionals.

The copyright of the data detailed within this guide belongs to CIE, email ciecb@cie.co.at
This document should be used in conjunction with CIE 150:2017 and CIE 126:1997 and not as a replacement for the procedures contained therein.

These documents can be obtained from <https://www.techstreet.com/cie/pages/home> and members of a National Committee of the CIE can purchase them with a discount of 66.7%.

Institution of Lighting Professionals
Regent House
Regent Place
Rugby
Warwickshire
CV21 2PN

Tel: (01788) 576492
Email: info@theilp.org.uk

Website: www.theilp.org.uk

Registered Charity Number 268547

This guidance note has been revised to reflect the changes in international guidance regarding obtrusive light as detailed in CIE 150:2017 *Guide on the limitation of the effects of obtrusive light from outdoor lighting installations*.¹ It also considers industry comment regarding the assessment and definition of obtrusive lighting.

Good lighting practice is the provision of the right light, at the right time, in the right place, controlled by the right system.

Humanity's invention of artificial light and its application in the external environment has done much to safeguard and enhance our night-time environment but, if not properly controlled, *obtrusive light* (sometimes referred to as light pollution) can present serious physiological and ecological problems.

Obtrusive light – whether it keeps you awake through a bedroom window, impedes your view of the night sky or adversely affects the performance of an adjacent lighting installation – is a form of pollution, which may also be a nuisance in law and which can be substantially mitigated without detriment to the lighting requirements of the task.

Sky glow, the brightening of the night sky, *glare* the uncomfortable brightness of a light source when viewed against a darker background, *light spill* the spilling of light beyond the boundary of the area being lit and *light intrusion* (“nuisance”)² are all forms of obtrusive light which may cause nuisance to others, or adversely affect fauna and flora as well as waste money and energy.

Considerations to be made

Think before you light. Is it necessary? What effect could it have on others? Has it the potential to cause a nuisance? How can you mitigate and manage any potential adverse effects from your lighting installation?

There are published standards and guidance for most lighting tasks, adherence to which will help mitigate obtrusive lighting aspects. Organisations from which full details of these standards can be obtained are given later in this Guidance Note.

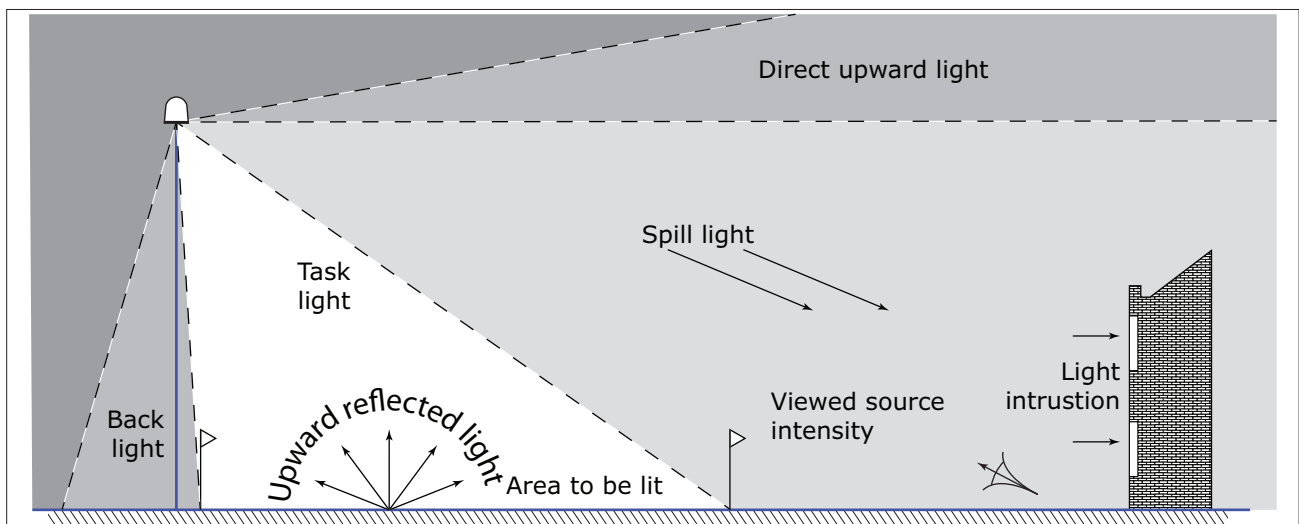

Figure 1: Types of intrusive light

1 The copyright of the data detailed within this guide belongs to CIE, email ciecb@cie.co.at. This document should be used in conjunction with CIE 150:2017 and CIE 126:1997 and not as a replacement for the procedures contained therein. These documents can be obtained from <https://www.techstreet.com/cie/pages/home> and members of a National Committee of the CIE can purchase them with a discount of 66.7%.

2 The term light trespass is sometimes used, but trespass is to physically encroach on land and light can't do that, so the term nuisance should always be used.

For the purpose of this Guidance Note the following two Commission Internationale De L'Éclairage (CIE) documents are specifically referenced; they provide guidance to the mitigation of obtrusive light from exterior lighting installations:

- CIE 150:2017 Guide on the limitation of the effects of obtrusive light from outdoor lighting installations;
- CIE 126-1997 Guidelines for minimizing sky glow

When considering any lighting installation these two documents should be referenced.

Whilst this Guidance Note specifically considers the effects from external lighting installations, the considerations within it can be relevant when considering modern office blocks and shop fronts where the main external facing structure is transparent and light from within the buildings could become a source of illumination to the exterior environment.

"Good Design Equals Good Lighting"

It cannot be stressed sufficiently that employing a competent lighting designer with proven experience in the lighting application being considered will provide a suitable lighting installation where all obtrusive lighting aspects are mitigated³.

Any lighting scheme consists of three basic elements: a light source, a luminaire (incorporating the optical control system) and a method of installation/mounting.

Light sources (lamps/LEDs)

Remember that the light source output in lumens is not the same as the wattage and that it is the former that is important in combating the problems of obtrusive light.

Most night-time visual tasks are only dependent on light radiated within the visual spectrum. It is therefore not necessary for light sources to emit either ultra-violet or infra-red radiation unless specifically required to do so. The majority of light sources used in external lighting do not contain these wavelengths or where they are present their spectral power is very low.

Research indicates that light from the blue end of the spectrum could have important adverse effects on fauna and flora. The lighting designer should consider the blue light spectral power of the light source and try to balance the needs of the task to be lit with any impact on fauna and flora within the environment.

Luminaires

The choice of luminaire with the right optical distribution at the right mounting height is critical to minimising light spill and obtrusive light effects while providing the right lighting performance on the task area.

Sky glow is the general diffuse sheen that is visible in the direction of large cities, airports, and industrial complexes. It occurs from both natural and artificial light sources and does not depend exclusively on the lighting design. It also depends on the atmospheric conditions (humidity, aerosols, clouds, haze, atmospheric pollution, etc). Light propagating into the atmosphere either directly from upward directed or incompletely shielded sources, or after reflection from the ground or other surfaces, is partially scattered back towards observers on the ground; the impact being shown in Table 1.

It is therefore important to consider the luminaire, its light distribution, how it is installed, and how it is set up.

For most general sports and area lighting installations the use of luminaires with asymmetric optics designed so that the front glazing is kept at or near parallel to

³ Competency can be determined through membership of a professional lighting body supported by the appropriate qualifications and experience in the application of lighting required.

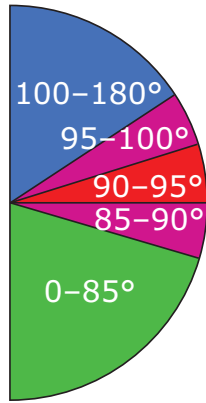

Indicative diagram

Table 1: The effect on the ability to view the night sky at various angles		
Angle of light emitted (degrees)	Sky glow effect	Glare effect
100 – 180	Local	Little
95 – 100	Significant	Some
90 – 95	High	High
85 – 90	Significant	High
0 – 85	Minimal	Some

the surface being lit should, if correctly aimed, ensure minimum obtrusive light.

Appendices 1 and 2 in this Guidance Note give more details of how to choose luminaires, and if necessary modify them through the use of louvres and shields.

Installation

In most cases it will be beneficial to use as high a mounting height as possible, giving due regard to the daytime appearance of the installation.

It should be noted that a lower mounting height is perhaps not better as can be seen from Figures 2a and 2b from CIE 150. A lower mounting height can create a higher level of light spill and require additional lighting points.

Keep glare to a minimum by ensuring that the main beam angle of all luminaires directed towards any potential observer is no greater than 70°. Higher mounting

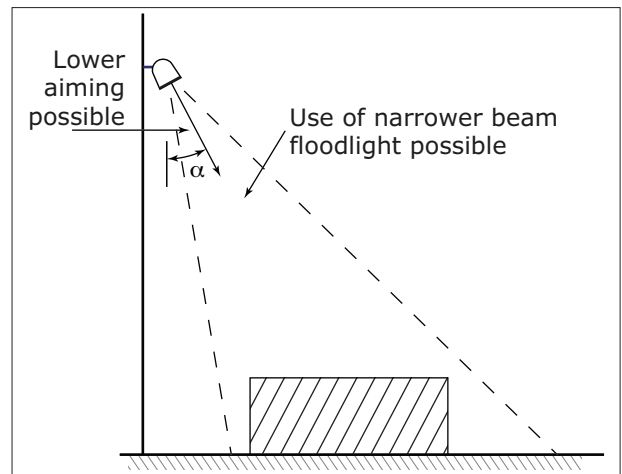

Figure 2a: Higher mounting height – less spill light and glare

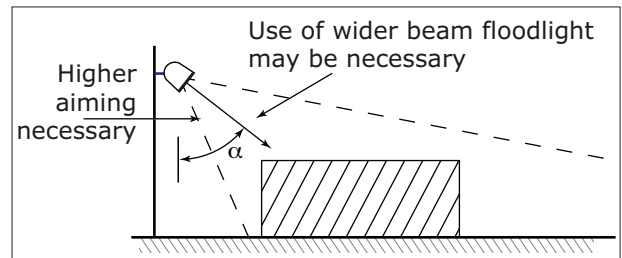

Figure 2b: Lower mounting height – more spill light and glare

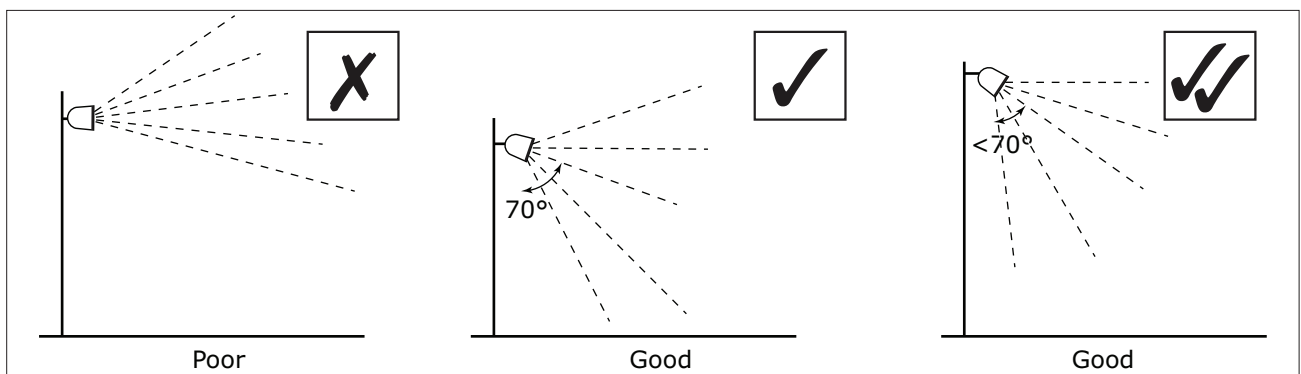

Figure 3 Luminaire aiming angles

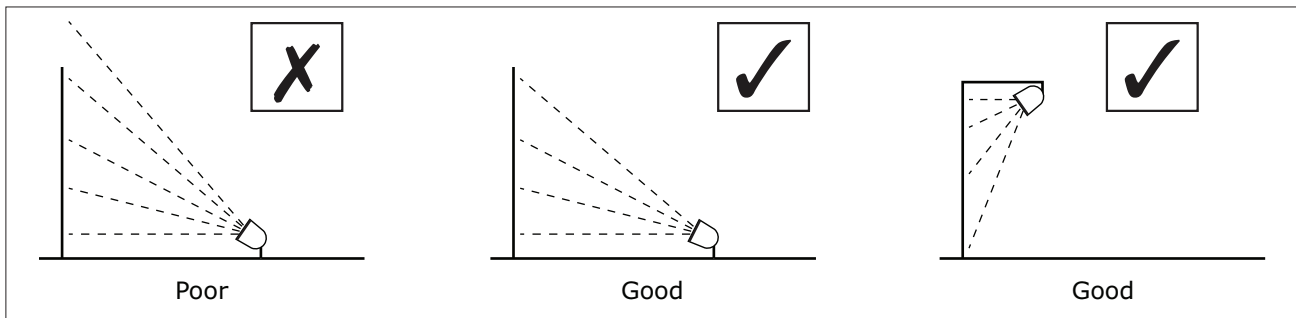

Figure 4 Façade illumination

heights allow lower main beam angles, which can assist in reducing glare.

In areas with low ambient light levels, glare can be very obtrusive, and extra care should be taken when positioning and aiming lighting equipment. With regard to domestic security lighting, the ILP produces an information leaflet GN09:2018 *Domestic exterior lighting: getting it right!* which is freely available from its website.

When lighting vertical structures such as advertising signs, direct light downwards wherever possible. If there is no alternative to up-lighting, as with much decorative lighting of buildings, then the use of luminaires with the correct optical distribution, coupled where required with shields, baffles and louvres, will help minimise spill light around and over the structure.

For road and amenity lighting installations, light near to and above the horizontal should normally be minimised to reduce glare and sky glow (Note the Upward Lighting Ratios (ULR's) advised in Tables 5 and 6). In rural areas the use of full horizontal cut off luminaires installed at 0° uplift will, in addition to reducing sky glow, help to minimise visual intrusion within the open landscape. However, in some urban locations, luminaires fitted with a more decorative bowl and good optical control of light should be acceptable and may be more appropriate.

Clean Neighbourhoods and Environment Act 2005 (CNEA)

The Clean Neighbourhoods and Environment Act 2005 (CNEA) gives local authorities and the Environment Agency additional powers to deal with a wide range of issues by classifying artificial light emitted from defined premises as a statutory nuisance.

The CNEA 2005 amended paragraph 79(1)(fb) of the Environmental Protection Act 1990 to extend the statutory nuisance regime to include light nuisance stating the following:

'artificial light emitted from premises so as to be prejudicial to health or a nuisance'.

Guidance produced on Sections 101 to 103 of the CNEA 2005 by DEFRA (DEFRA, April 2006) extends the duty on local authorities to ensure their areas are checked periodically for existing and potential sources of statutory nuisances including nuisances arising from artificial lighting. Local authorities must take reasonable steps to investigate complaints of such nuisances from artificial light. Once satisfied that a statutory nuisance exists or may occur or recur, local authorities must issue an abatement notice (in accordance with section 80(2) of the Environmental Protection Act 1990), requiring that the nuisance cease or be abated within a set timescale.

National Planning Policy Framework (NPPF)

The NPPF was introduced as a more concise and useable planning document to aid developers and designers in the design and construction of developments within the UK.

The National Planning Policy Framework 2019 makes little reference to lighting with regard to the control of obtrusive light with section being the only reference, which states:

c) limit the impact of light pollution from artificial light on local amenity, intrinsically dark landscapes and nature conservation.

With regard to the planning aspect, many local planning authorities (LPAs) have already produced, or are producing, policies that within the planning system will become part of their local development framework. For new developments there is an opportunity for LPAs to impose planning conditions related to external lighting, including curfew hours.

National planning policy

The national on-line planning guidance resource looks at when lighting pollution concerns should be considered.

The guidance provides a high-level overview for planners, with links to appropriate documents looking at the subject through seven discussion points:

- What light pollution considerations does planning need to address?
- What factors can be considered when assessing whether a development proposal might have implications for light pollution?
- What factors are relevant when considering where light shines?
- What factors are relevant when considering when light shines?
- What factors are relevant when considering how much the light shines?

- What factors are relevant when considering possible ecological impacts of lighting?
- What other information is available that could inform approaches to lighting and help reduce light pollution?

It is to be hoped that whilst the guide does not specifically require it planners will consider the application of artificial light and consult with lighting designers. The planners can then be advised on the planning conditions that might be applicable for each project and review any submissions to determine if the planning conditions have been met.

The Scottish Executive has published a design methodology document (March 2007) entitled “*Controlling Light Pollution and Reducing Lighting Energy Consumption*” to further assist in mitigating obtrusive light elements at the design stage.

Environmental zones

It is recommended that local planning authorities specify the environmental zones given in Table 2 for exterior lighting control within their development plans.

Design guidance

The following limitations based upon CIE150 may be supplemented or replaced by an LPA’s own planning guidance for exterior lighting installations. As lighting design is not as simple as it may seem, you are advised to consult and/or work with a competent professional lighting designer when considering any exterior lighting.

Table 2: Environmental zones

Zone	Surrounding	Lighting environment	Examples
E0	Protected	Dark (SQM 20.5+)	Astronomical Observable dark skies, UNESCO starlight reserves, IDA dark sky places
E1	Natural	Dark (SQM 20 to 20.5)	Relatively uninhabited rural areas, National Parks, Areas of Outstanding Natural Beauty, IDA buffer zones etc.
E2	Rural	Low district brightness (SQM ~15 to 20)	Sparsely inhabited rural areas, village or relatively dark outer suburban locations
E3	Suburban	Medium district brightness	Well inhabited rural and urban settlements, small town centres of suburban locations
E4	Urban	High district brightness	Town/city centres with high levels of night-time activity

Notes:

1. Where an area to be lit lies on the boundary of two zones the obtrusive light limitation values used should be those applicable to the most rigorous zone.
2. Rural zones under protected designations should use a higher standard of policy.
3. Zone E0 must always be surrounded by an E1 Zone.
4. Zoning should be agreed with the local planning authority and due to local requirements a more stringent zone classification may be applied to protect special/specific areas.
5. SQM (Sky Quality Measurements) referenced by the International Dark-Sky Association (IDA), the criteria for E0 being revised in mid 2019 but not retrospective.
6. Astronomical observable dark skies will offer clearer views of the Milky Way and of other objects such as the Andromeda galaxy and the Orion Nebula.
7. Although values of SQM 20 to 20.5 may not offer clear views of astronomical dark sky objects such as the Milky Way, these skies will have their own relative intrinsic value in the UK.

Table 3 (CIE 150 table 2): Maximum values of vertical illuminance on properties.

Light technical parameter	Application conditions	Environmental zone				
		E0	E1	E2	E3	E4
Illuminance in the vertical plane (E_v)	Pre-curfew	n/a	2 lx	5 lx	10 lx	25 lx
	Post-curfew	n/a	<0.1 lx*	1 lx	2 lx	5 lx

Note:

- * If the installation is for public (road) lighting then this may be up to 1 lx.

Recommended maximum values of light parameters for the control of obtrusive light

Limitation of illumination on surrounding properties

Light intrusion/nuisance

Limits apply to nearby dwellings/premises or potential dwellings/premises and specifically windows; the values are the summation of all lighting installations.

Spill light

Table 3 can also be considered for the management of spill light; however, designers must consider the task performance requirements of any adjacent lit areas and ensure that any spill light does not adversely affect these performance parameters as this could affect their safe use. This may result in a need to minimise spill and intrusive lighting values to less than might be expected for the environmental zone within which the installation lies.

Limitation of bright luminaires in the field of view.

The limits for the luminous intensity of bright luminaires are dependent on the viewing distance d , (between the observer and the bright luminaire(s)) and the projected area A_p , of the bright part of the luminaire in the direction of the observer.

Table 4 shows the maximum values for the luminous intensity of luminaires in designated directions where views of bright surfaces of luminaires are likely to be a nuisance to occupants of premises or from positions where such views are likely to be maintained, that is, not momentary or short-term.

Considerations to aid the application of Table 4 and the assessment process.

- a) The assessment of A_p for observers can prove difficult and will vary for all observer positions and distances. To aid this assessment values of A_p corresponding to the geometric mean diameter of each luminaire group have been extracted from CIE 150 Annex C and included within Table 4. These areas can be considered for an assessment of likely A_p in the observer direction to calculate a maximum luminous intensity value.
- b) The above information is applicable for the consideration of a single luminaire but where two or more luminaires are located in close proximity to each other that to the observer they appear as a single light source then the assessment shall be undertaken based upon the combined bright surfaces of luminaires (A_p) in the direction of the observer or, from positions where such views are likely to be maintained.
- c) In installations that involve mast lighting the luminaires will often be viewed against the night sky. The contrast between the background sky and the bright surface areas of the luminaires can be considerable. In such installations the curfew levels set for each environmental zone shall be applied with the exception that such installations within an E4 zone will be designed to suit the curfew requirements of an E3 zone.

Limitation of the effects on transport systems

Limits apply where users of road networks are subject to a reduction in the ability to see essential information. CIE 150 2017; Table 5 gives values that are for relevant positions and for viewing directions in the path of travel.

This assessment does not just apply to road lighting installations but to any installation where luminaires positioning falls under the above definition.

Limitation of sky glow

See Tables 6 and 7

Table 4 (CIE 150 table 3 (amended)): Limits for the luminous intensity of bright luminaires⁴.

Light technical parameter	Application conditions	Luminaire group (projected area A_p in m^2)					
		$0 < A_p \leq 0.002$	$0.002 < A_p \leq 0.01$	$0.01 < A_p \leq 0.03$	$0.03 < A_p \leq 0.13$	$0.13 < A_p \leq 0.50$	$A_p > 0.5$
Maximum luminous intensity emitted by luminaire (I in cd)	E0						
	Pre-curfew	0	0	0	0	0	0
	Post-curfew	0	0	0	0	0	0
	E1						
	Pre-curfew	0.29 <i>d</i>	0.63 <i>d</i>	1.3 <i>d</i>	2.5 <i>d</i>	5.1 <i>d</i>	2,500
	Post-curfew	0	0	0	0	0	0
	E2						
	Pre-curfew	0.57 <i>d</i>	1.3 <i>d</i>	2.5 <i>d</i>	5.0 <i>d</i>	10 <i>d</i>	7,500
	Post-curfew	0.29 <i>d</i>	0.63 <i>d</i>	1.3 <i>d</i>	2.5 <i>d</i>	5.1 <i>d</i>	500
	E3						
	Pre-curfew	0.86 <i>d</i>	1.9 <i>d</i>	3.8 <i>d</i>	7.5 <i>d</i>	15 <i>d</i>	10,000
	Post-curfew	0.29 <i>d</i>	0.63 <i>d</i>	1.3 <i>d</i>	2.5 <i>d</i>	5.1 <i>d</i>	1,000
	E4						
	Pre-curfew	1.4 <i>d</i>	3.1 <i>d</i>	6.3 <i>d</i>	13 <i>d</i>	26 <i>d</i>	25,000
Post-curfew	0.29 <i>d</i>	0.63 <i>d</i>	1.3 <i>d</i>	2.5 <i>d</i>	5.1 <i>d</i>	2,500	
Aid to gauging A_p		2 to 5cm	5 to 10cm	10 to 20cm	20 to 40cm	40 to 80cm	>80cm
Geometric mean of diameter (cm)		3.2	7.1	14.1	26.3	56.6	>80
Corresponding A_p representative area (m^2)		0.0008	0.004	0.016	0.063	0.251	>0.5

Notes:

1. *d* is the distance between the observer and the glare source in metres;
2. A luminous intensity of 0 cd can only be realised by a luminaire with a complete cut-off in the designated directions;
3. A_p is the apparent surface of the light source seen from the observer position
4. For further information refer to Annex C of CIE 150
5. Upper limits for each zone shall be taken as those with column $A_p > 0.5$

Limitations of the effect of over-lit building façades and signs

Table 8 provides recommendations regarding luminance values that provide visibility in order that a balanced urban lighting master plan can be considered and

such lighting does not cause negative impacts such as a continuous increase in the lighting levels (ratcheting) between buildings and within areas and light pollution.

Illuminated advertising signage should be assessed as advised in the ILP's Professional Lighting Guide *The brightness of illuminated advertisements*, (PLG 05)

⁴ Amended based upon the approach taken by NSVV Nederlandse Stichting Voor Verlichtingskunde (Dutch: Dutch Foundation for Illumination; The Netherlands) and to consider CIE 150 Annex C Table C.2

Table 5 (CIE 150 table 4): Maximum values of threshold increment and viewing direction in the path of travel.

Light technical parameter	Road classification*			
	No road lighting	M6/M5	M4/M3	M2/M1
Veiling luminance [†] (L_v)	0.037 cd/m ²	0.23 cd/m ²	0.40 cd/m ²	0.84 cd/m ²
Threshold increment	15% based on adaption luminance of 0.1 cd/m ²	15% based on adaption luminance of 1.0 cd/m ²	15% based on adaption luminance of 2.0 cd/m ²	15% based on adaption luminance of 5 cd/m ²

Notes:

* Road classifications as given in CIE 115:2010

† The veiling luminance values specified in this table are based upon on a permissible TI value of 15%

Definitions:

TI The measure of disability glare (the reduction in visibility caused by intense light sources in the field of view) expressed as the percentage increase in contrast required between an object and its background for it to be seen equally well with a source of glare present. Note: Higher values of TI correspond to greater disability glare.

L_v The luminance that would need to be superimposed on a scene in object space to reduce the scene's contrast by an amount equal to the added retinal illuminance from scattered light on the scene's retinal image. It is most commonly used to describe the contrast-reducing effect of a glare source in the field of view.

Table 6 (CIE 150 table 5): Maximum values of upward light ratio (ULR) of luminaires.

Light technical parameter	Environmental zones				
	E0	E1	E2	E3	E4
Upward light ratio (ULR)/%	0	0	2.5	5	15

Note:

This does not take into account the effect of light reflected upwards from ground that also contributes to sky glow. This is the traditional method to limit sky glow and is suitable to compare different single luminaires.

For illuminated advertising signs the aim should be to achieve the limits advised in PLG05.

Table 7 (CIE 150 table 6): Maximum values of upward flux ratio of installation (of four or more luminaires).

Light technical parameter	Type of installation	Environmental zones				
		E0	E1	E2	E3	E4
Upward flux ratio (UFR)/%	Road	n/a	2	5	8	12
	Amenity	n/a	n/a	6	12	35
	Sports	n/a	n/a	2	6	15

Notes:

Table 7 allows the effect of both direct and reflected upward components of a whole installation to be taken into account. The factor being the upward flux ratio (UFR) and CIE 150 suggests that table 7 is used for all installations consisting of four or more luminaires.

Clauses 6.4.2 and 6.4.3 of CIE 150:2017 describe the calculation methods for both ULP and UFR.

Light emitted just above the horizontal in a zone between 90° and 110° is extra critical for sky glow in large open areas around observatories. An additional measure in these areas limits the luminous intensities ($I_{90} - I_{110}$) as follows:

- between 90° and 100° < 0.5 cd/1000lm;
- between 100° and 110° 0 cd.

Table 8 (CIE 150 table 7): Maximum permitted values of average surface luminance (cd/m²).

Light technical parameter	Application conditions	Environmental zones				
		E0	E1	E2	E3	E4
Building façade luminance (L_b)	Taken as the product of the design average illuminance and reflectance divided by n	< 0.1	< 0.1	5	10	25
Sign luminance (L_s)	Taken as the product of the design average illuminance and reflectance divided by n, or for self-luminous signs, its average luminance.	< 0.1	50	400	800	1.000

Note:

The values apply to both pre- and post-curfew, except that in zones 0 and 1 the values shall be zero post curfew. The values for signs do not apply to signs for traffic control purposes.

Relevant publications and standards

British Standards

- BS 5489-1:2013 *Code of practice for the design of road lighting – Part 1 Lighting of roads and public amenity areas;*
- BS EN 13201-2:2015 *Road lighting. Part 2: Performance requirements;*
- BS EN 13201-3:2015 *Road lighting. Part 3: Calculation of performance;*
- BS EN 13201-4:2015 *Road lighting. Part 4: Methods of measuring lighting performance;*
- BS EN 12193:2018 *Light and lighting. Sports lighting;*
- BS EN 12464-2:2014 *Lighting of work places. Outdoor work places;*
- PD CEN TR 13201-1:2014 *Road lighting. Guidelines on selection of lighting classes.*

CIE publications

- CIE 001 *Guidelines for minimizing urban sky glow near astronomical observatories;*
- CIE 094-1993 *Guide for floodlighting;*
- CIE 112-1994 *Glare evaluation system for use within outdoor sport and area lighting;*
- CIE 115:2010 *Lighting of roads for motor and pedestrian traffic;*
- CIE 126:1997 *Guidelines for minimizing sky glow;*
- CIE 129:1998 *Guide for lighting exterior work areas;*
- CIE 136:2000 *Guide to the lighting of urban areas;*
- CIE 150:2017 *Guide on the limitation of the effects of obtrusive light from outdoor lighting installations;*
- CIE 169:2005 *Practical design guidelines for the lighting of sport events for colour.*

ILP publications

- PLG04 *Guidance on undertaking environmental lighting impact assessments;*

- PLG05 *The brightness of illuminated advertisements;*
- PLG06 *Guidance on installation and maintenance of seasonal decorations and lighting column attachments*
- GN09 *Domestic exterior lighting: getting it right!*

SLL/CIBSE Publications

- LG01 *The industrial environment* (2018);
- LG04 *Sports lighting;*
- LG06/16 *The exterior environment;*
- LGL0L *Guide to limiting obtrusive light.*

NB: These notes are intended as guidance only and the application of the values given in the various tables should be given due consideration along with all other factors in the lighting design. Lighting is a complex subject with both objective and subjective criteria to be considered. The notes are therefore no substitute for professionally assessed and designed lighting, where the various and maybe conflicting visual requirements need to be balanced.

Acknowledgements

Allan Howard – WSP (Chair)

Peter Raynham – UCL

Dan Oakley – South Downs National Park

Appendix 2 images – acdc

Appendix 1

Outdoor luminaire classification system

Based upon CIE 150:2017 and for the purpose of this and associated documents the following figures illustrate the luminaire classification (CIE 150:2017)

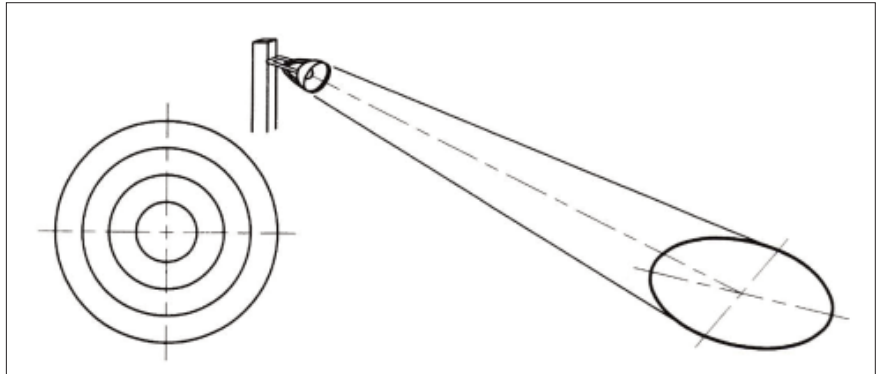
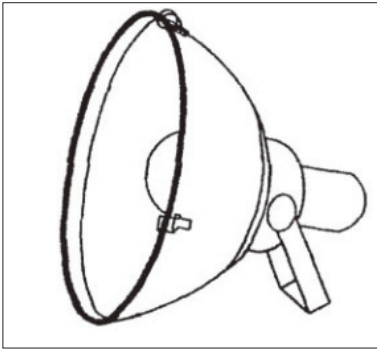

Type A: Floodlight/projector producing a symmetrical beam

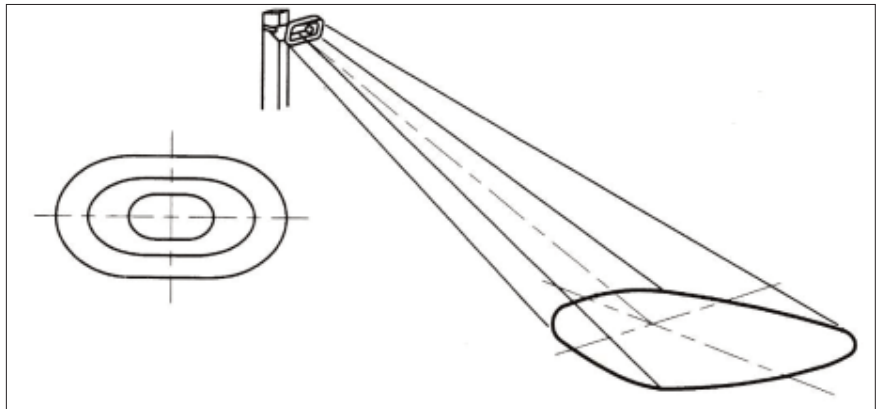
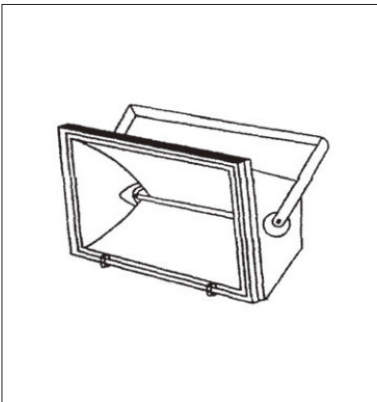

Type B: Floodlight/projector producing a fan-shaped beam

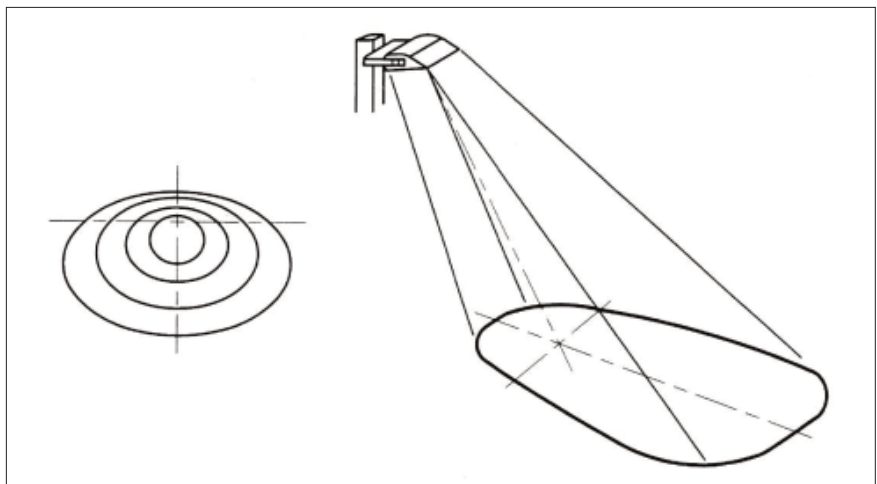
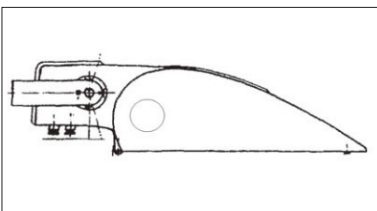

Type C: Floodlight/projector producing a double asymmetric distribution in the vertical plane

Appendix 2

Illustrations of luminaire accessories for limiting obtrusive light



Luminaire with cowl, hood and shield



With louvre



With cowl