

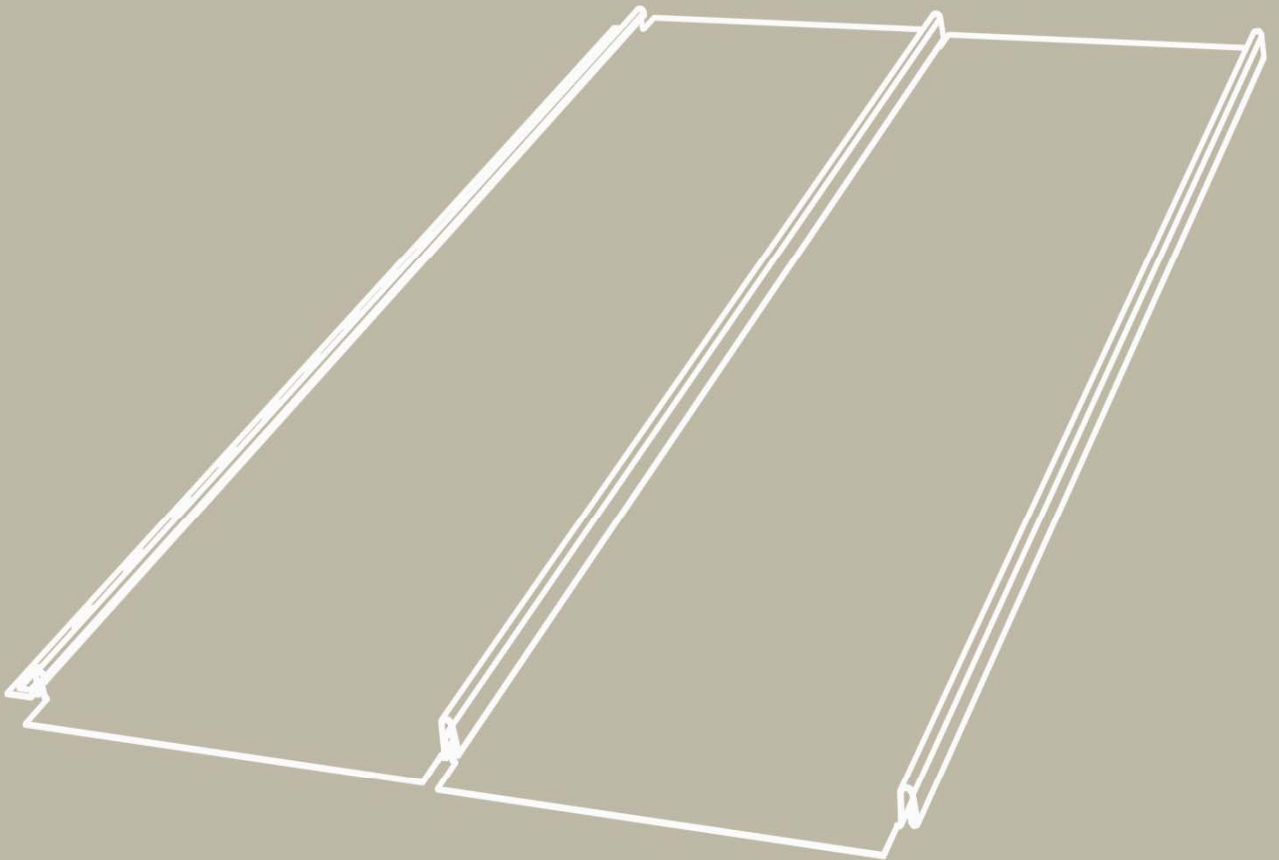

Colorcoat Urban®

Specification Guide

Tata Steel Colors



Introduction

Tata Steel introduces a product that provides an innovative and sustainable solution for roofs and walls, specifically designed for the urban environment.

- Matt colour range specifically designed for the urban fabric.
- Stable colour ensures an aesthetic of consistent, even shade.
- Zero maintenance for up to 40 years.
- Can be laid to a minimum pitch of 5°.
- Eco-designed to remove environmentally harmful elements and deliver the lowest impact without reducing the performance.
- 100% recyclable and Carbon Neutral, via a government approved carbon measuring, reducing and offsetting scheme.
- Simple integration of renewable technologies, helping achieve forthcoming legislation.

The specification guide explains the standard range of details and components used to design a roof using the Colorcoat Urban® system.

Particular attention should be made of the panel widths for low pitch applications in high wind speed locations.

Product Selector

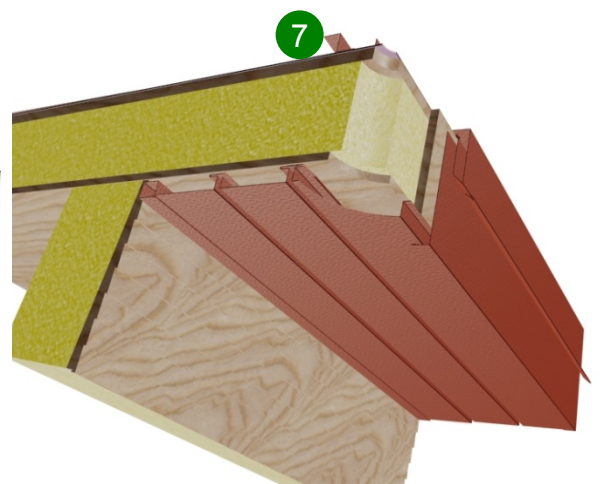
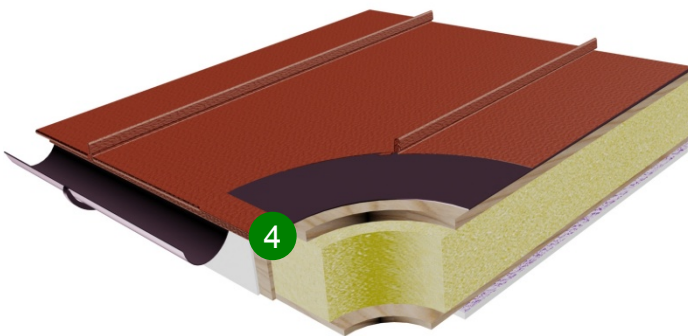
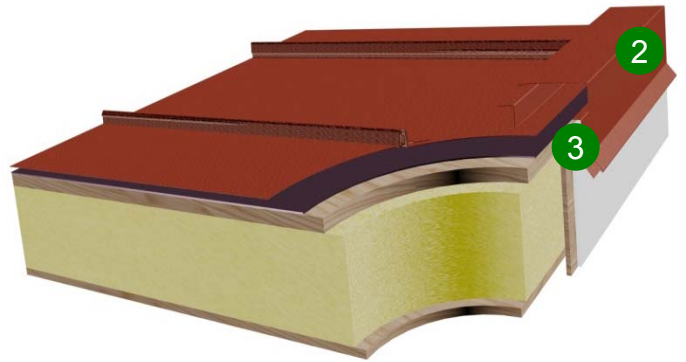
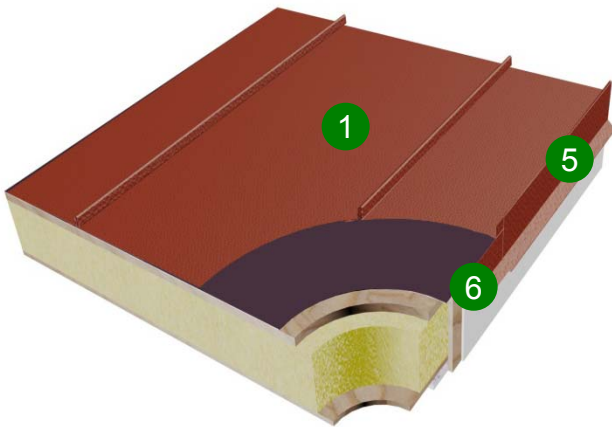

Product Selector

Product description	Reference code	Quantity	Detail No.
Urban Seam® profile			
514 mm width	CU051400	m ²	1
305 mm width	CU030500	m ²	
Ridge Profiles*			
Mono Ridge	CU002400	3m	2
Mono Ridge Backing Plate	CU002500	3m	3
Stepped Ridge	CU004500	3m	
Standard Duo Ridge	CU004600	3m	
Large Duo Ridge	CU004700	3m	
Mono Ridge End Caps			
Left Hand	CU012700	1	
Right Hand	CU022700	1	
Duo Pitch Ridge End Caps			
Stepped Ridge	CU014500	1	
Standard Duo Ridge	CU014600	1	
Large Duo Ridge	CU024700	1	
Eave Detail	CU003600	3m	4
Verge Detail			
Verge	CU002700	3m	5
Verge Backing Plate	CU002800	3m	6
Z bar			
Notched Z bar	CU004105	3m	7
Ventilated Z bar	CU004205	3m	

00 – last two figures denote colour code

* Contractor to specify roof pitch

Product Selector

Product description	Reference code	Quantity	Detail No.
Fixings			
3.5 x 38 mm ring pin nails	CU020100	1000	
M4 x 20 mm Pan Head Stainless Steel Screw	CU020200	1000	
Colour Matched Pot rivets, Aluminium / Stainless shaft 4.8 x 15 mm	CU020300	100	
Colour matched stainless steel low profile head 5.5 x 35 mm	CU020400	100	
Ancillary products			
Touch up paint with brush	CU030100	125ml	
Coloured Sealant Black	CU030201	300cc	
Coloured Sealant Grey	CU030202	300cc	
Filler Block 510 x 30 x 30 mm	CU030300	Pack of 10	

Colour choice

The naturally inspired colour range can blend with the urban landscape, ensuring the building harmoniously integrates with the local vernacular.



Winter Sky 01
RAL 7040



Alaska 02
RAL 7000



Merlin 03
BS 18B25



Anthracite 04
RAL 7016

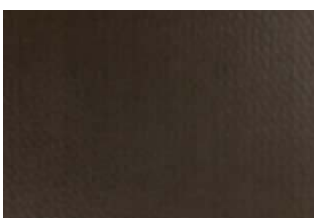

Oxidised 07
RAL 8014 or 0502010



Terracotta 05
BS 04C39

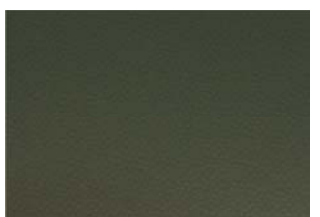

Green Grey 06
RAL 6003 or 1504010



Patina 08
RAL 6027 or 1807025

Urban fabric

The Colorcoat Urban® colour range has been inspired by architects specifically for the urban environment.

As such they partner harmoniously with existing buildings and building envelope materials, including glass, wood, brick, stone and render.

Matt shades

The tonal colour range of the matt shades have been carefully selected. With the ability to achieve a stable colour ensures a consistency of even colour, which is unachievable from most other roofing materials.

Note:

Hand sample requests are available online at www.colorcoaturban.com or via Colorcoat Connection® helpline on +44 (0) 1244 892434.

Wind Speed and Fixing Chart

Essential points

- For all buildings between 1 – 8 stores at a pitch 5° - 45°
- Please refer to the following specification

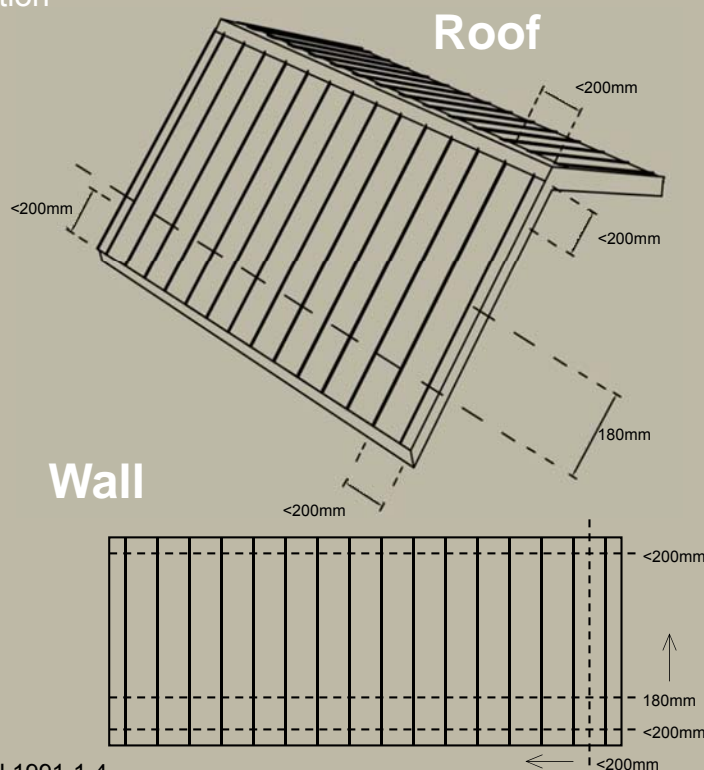

- In accordance with BS 6339-2 and BS5534 & BS EN 1991-1-4 Section 7.2.5
- Specification of the 514mm/305mm wide panel is dependant location, wall height, storey height and roof pitch.*A structural engineer should complete a wind uplift calculation for your specific area before making any final decision. Please note table below is for guidance only;

- When Building over 3 storey or in exposed locations the structural engineer should complete a wind uplift calculation and provide Tata Steel with details so the best fixing solutions can be developed.
- Please follow our recommendations for fixing the Urban Seam® profile as described.
- Fixings along the eaves, verge and Mono Ridge backing plates require fitting at 200mm fixing centres. Same principle applies to wall.
- Fixings into the panel nailing strip must be at 180mm centres.
- For detailed nailing patterns please refer to fixing of Urban Seam profile section in the installation guide.
- Urban Seam® profile is fixed to 18mm OSB 3, WBP or Marine Ply board. (15mm board is used for SIP panels) For other board types or dimensions please contact our technical advice line.
- For any advise and technical assistance in regards to wind speed or fixing positions please e-mail or contact our technical advise on Colourcoaturban@tatasteel.com

Roof Pitch (Degree) & Wall	No. Storeys	Wind Speed V_s	Panel Width 305mm	Panel Width 514mm
(5-9)	<3	≥ 25	✓	X
	4-8		✓	X
(5-9)	<3	<25	✓	✓
	4-8		✓	X
≥ 10	<3	≥ 25	✓	✓
	4-8		✓	X
≥ 10	<3	<25	✓	✓
	4-8		✓	✓

Ordering the Roof or Wall

Essential points

Tata Steel manufactures the roof or wall based on measurements provided by the customer.

These details can be found on the drawing produced by the roof truss or SIP panel manufacturer.

The maximum panel length is 12.5 metres

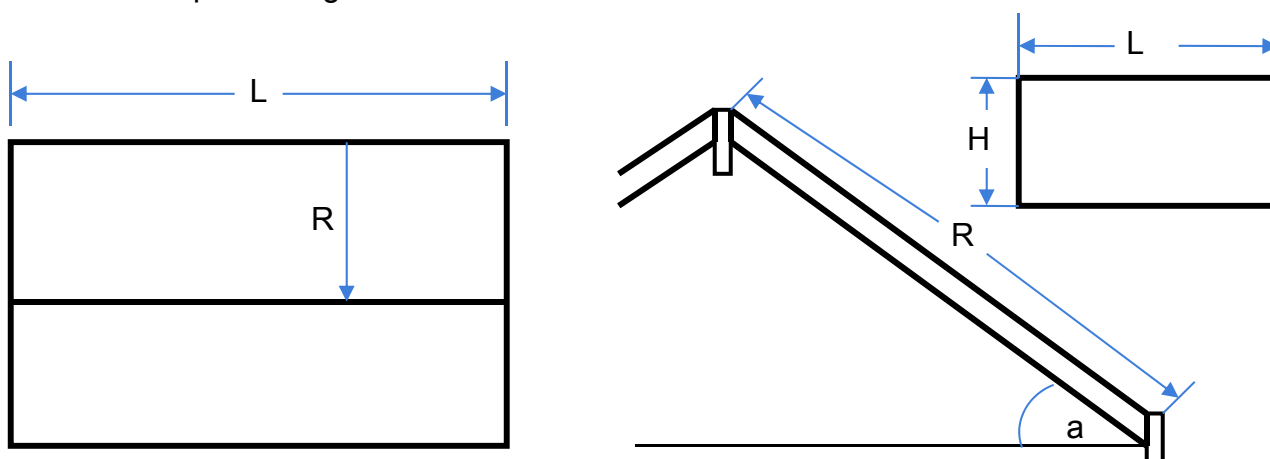

Estimating straight roofs or walls

For the straight roof we need four details: length (L), rafter length including fascia board (R), angle of pitch (a) and whether it is mono or duo pitch roof. For a wall we need length (L) and height (H) and any potential junctions or breaks.

Estimating fixings

For the Urban Seam® profile at 514mm wide then you will need a minimum 6 fixings per square metre, and four fixings per linear metre along the eaves and verges, and at the ridge it will be 8 fixings per linear meter for the duo pitch and 4 for the mono pitch. If using screws for the ridge then the spacing is every 500mm halving the number of ridge fixings.

Panel Lengths

The panel maximum length (R) is 12.5 metres, this is due to the thermal expansion of the panel. How to deal with roof over 12.5 metres is to split the panels or create a change in fall in the roof, for example a mansard or join two panels.

Urban Profile

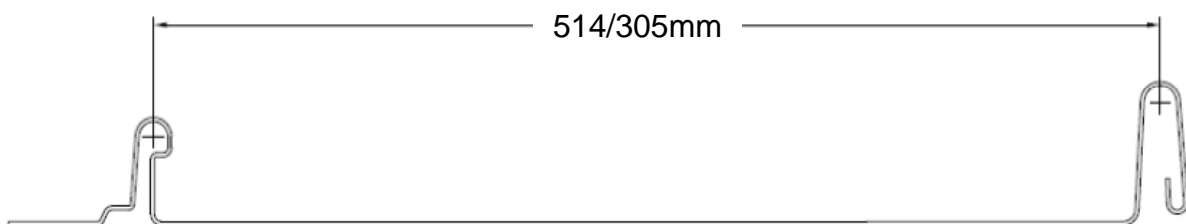
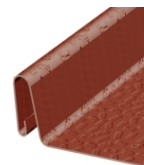
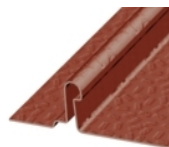

Technical Details

Urban Seam® Profile

Standard Details

- ASU01 – Duo Pitch Ridge
- ASU02 – Eave Detail
- ASU03 – Verge Detail
- ASU04 – Mono Ridge
- ASU05 – Top Abutment
- ASU06 – Side Abutment
- ASU07 – Valley
- ASU08 – Hip

Ventilation

- ASU010 – Ventilated Duo Ridge Detail
- ASU011 – Ventilated Eave Detail
- ASU012 – Ventilated Mono Detail
- ASU013 – Ventilated Duo Ridge Low Pitch
- ASU014 – Ventilated Top Abutment Low Pitch

Build Up Options

- ASU015 – Roof Build Up Options
- ASU016 – Cross Section Cold Roof
- ASU017 – SIP Panel Build Up

Additional Details

- ASU020 – Window detail (Roof lights)
- ASU021 – Mansard Detail
- ASU022 – Renewable fixing Clamp
- ASU022 02 – Renewable fixing Clamp Assembly
- ASU023 – Joining panels
- ASU024 – Square Penetration
- ASU025 – SVP or round Chimney
- ASU026 – Fascia , Soffit and internal gutter
- ASU027 – Weatherboard

Wall Details

- ASU030 – Wall Details
- ASU031 – Window detail
- ASU032 – External and Internal Corner
- ASU033 – Laying panels horizontally

For electronic versions of the technical drawings then please e-mail or contact our technical advise line on Colourcoaturban@tatasteel.com

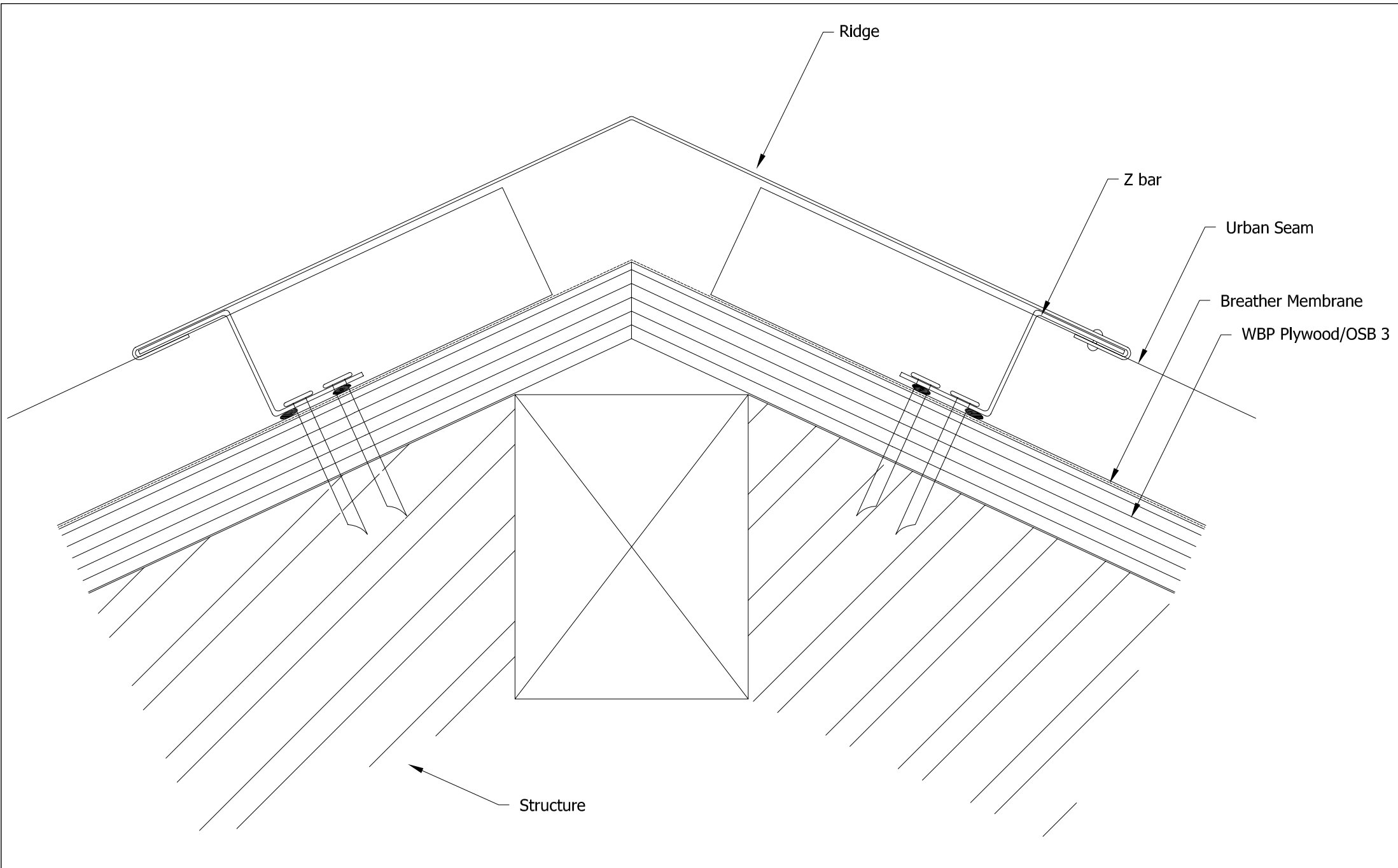

This drawing is the exclusive property of Tata Steel must not be copied or otherwise reproduced in anyway whatsoever without the express consent in writing of the corporation. The contents of the drawing must be treated as strictly confidential and must not be disclosed to any third party without the express consent in writing of the corporation.

Title

Duo Pitch Ridge

Drawing No.

ASU01

Scale : N/A

Copyright - Tata Steel © 2012

Rev: 0

Colorcoat Urban
Shotton Works
Deeside
CH5 2NH

Tel: +44 (0)1244 89 2449
Fax: +44 (0)1244 89 2442
www.colorcoaturban.com

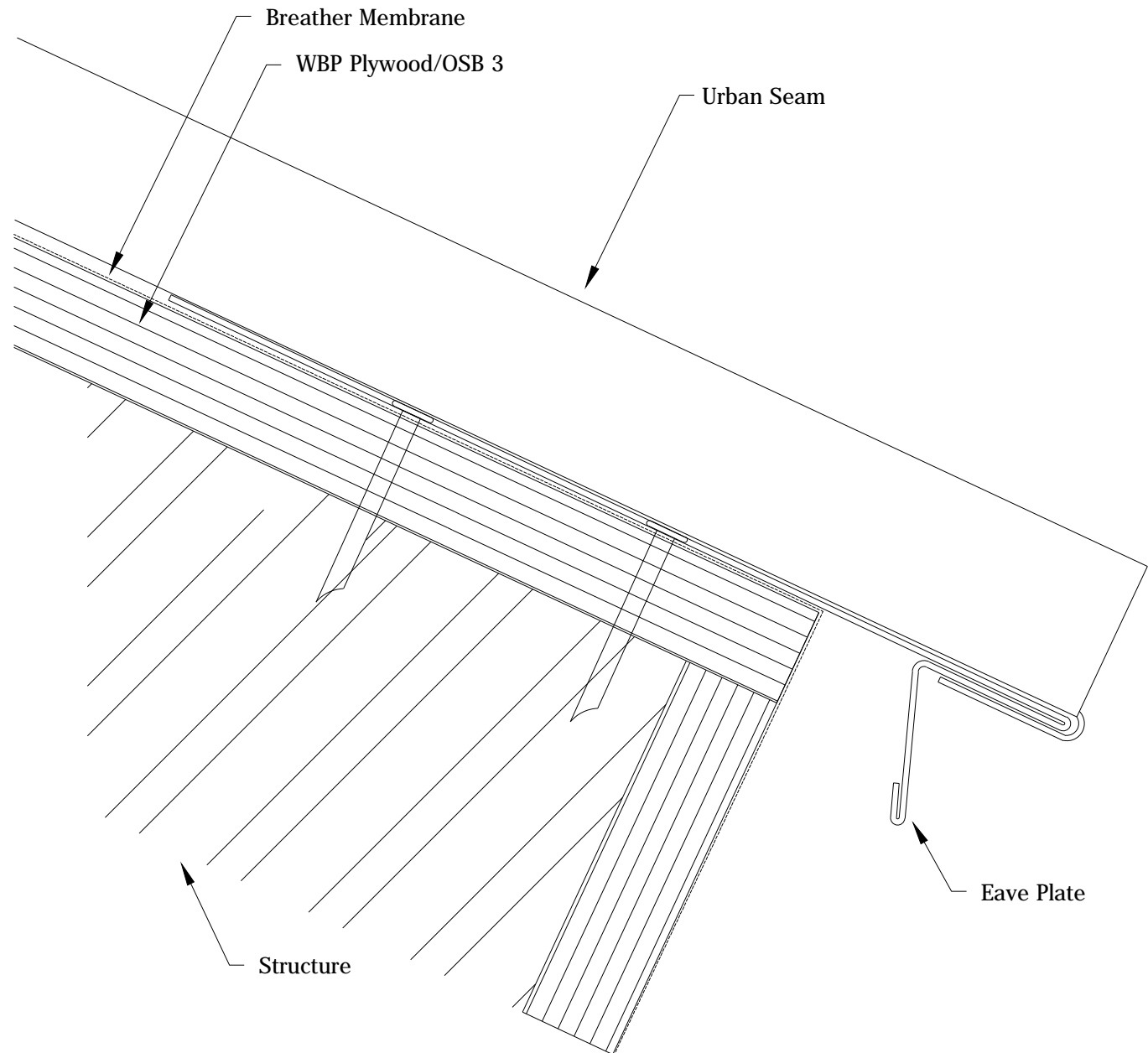

This drawing is the exclusive property of Tata Steel must not be copied or otherwise reproduced in anyway whatsoever without the express consent in writing of the corporation. The contents of the drawing must be treated as strictly confidential and must not be disclosed to any third party without the express consent in writing of the corporation.

Title	Eave Detail
Drawing No.	ASU02

Scale : N/A
Rev: O

Copyright - Tata Steel ₹ 2012	
Colorcoat Urban Shotton Works Deeside CH5 2NH	Tel: +44 (0)1244 89 2449 Fax: +44 (0)1244 89 2442 www.colorcoaturban.com

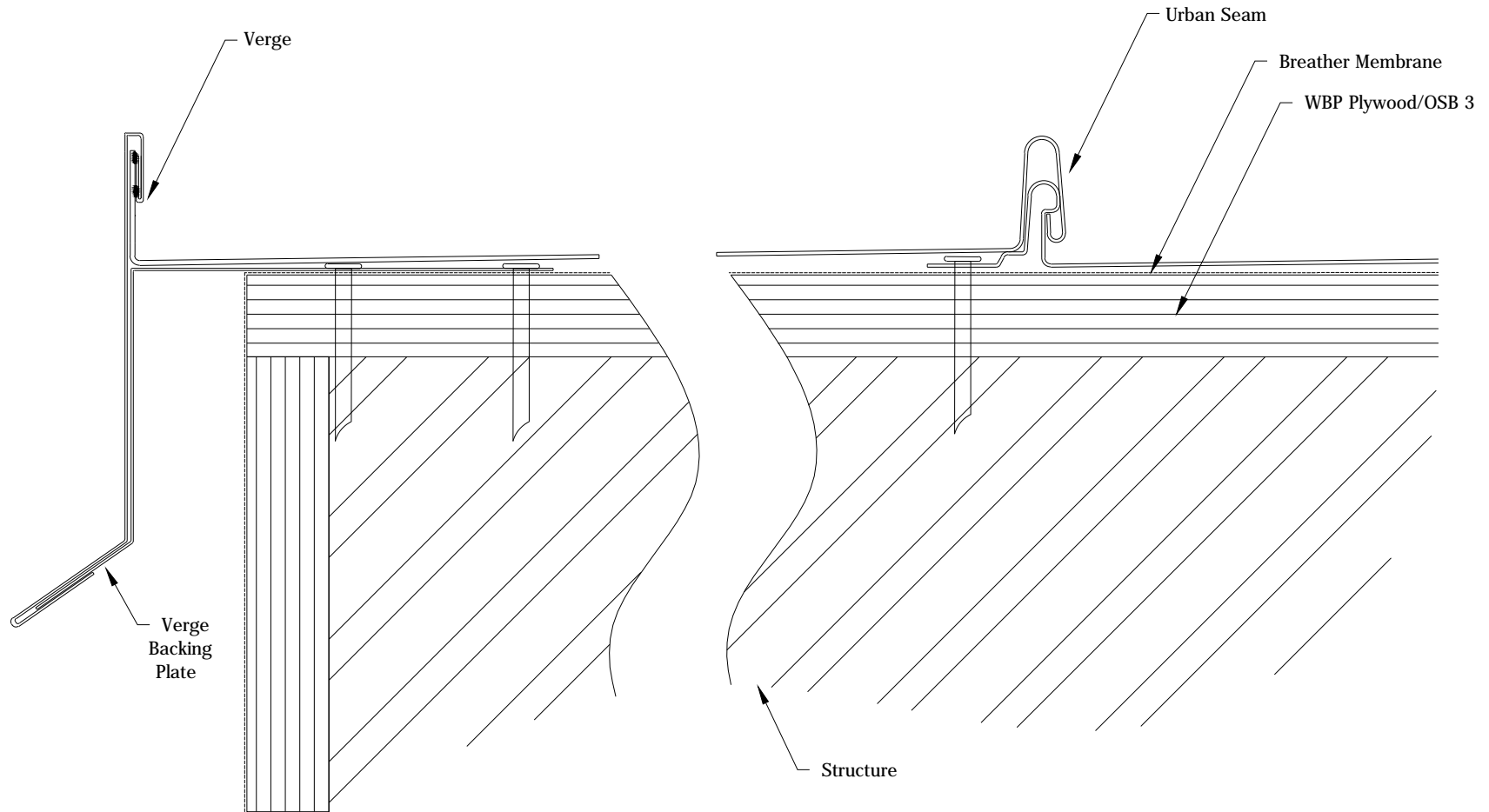

This drawing is the exclusive property of Tata Steel must not be copied or otherwise reproduced in anyway whatsoever without the express consent in writing of the corporation. The contents of the drawing must be treated as strictly confidential and must not be disclosed to any third party without the express consent in writing of the corporation.

Title	Verge Detail
Drawing No.	ASU03

Scale : N/A
Rev: 0

Copyright - Tata Steel ₹ 2012	
Colorcoat Urban Shotton Works Deeside CH5 2NH	Tel: +44 (0)1244 89 2449 Fax: +44 (0)1244 89 2442 www.colorcoaturban.com

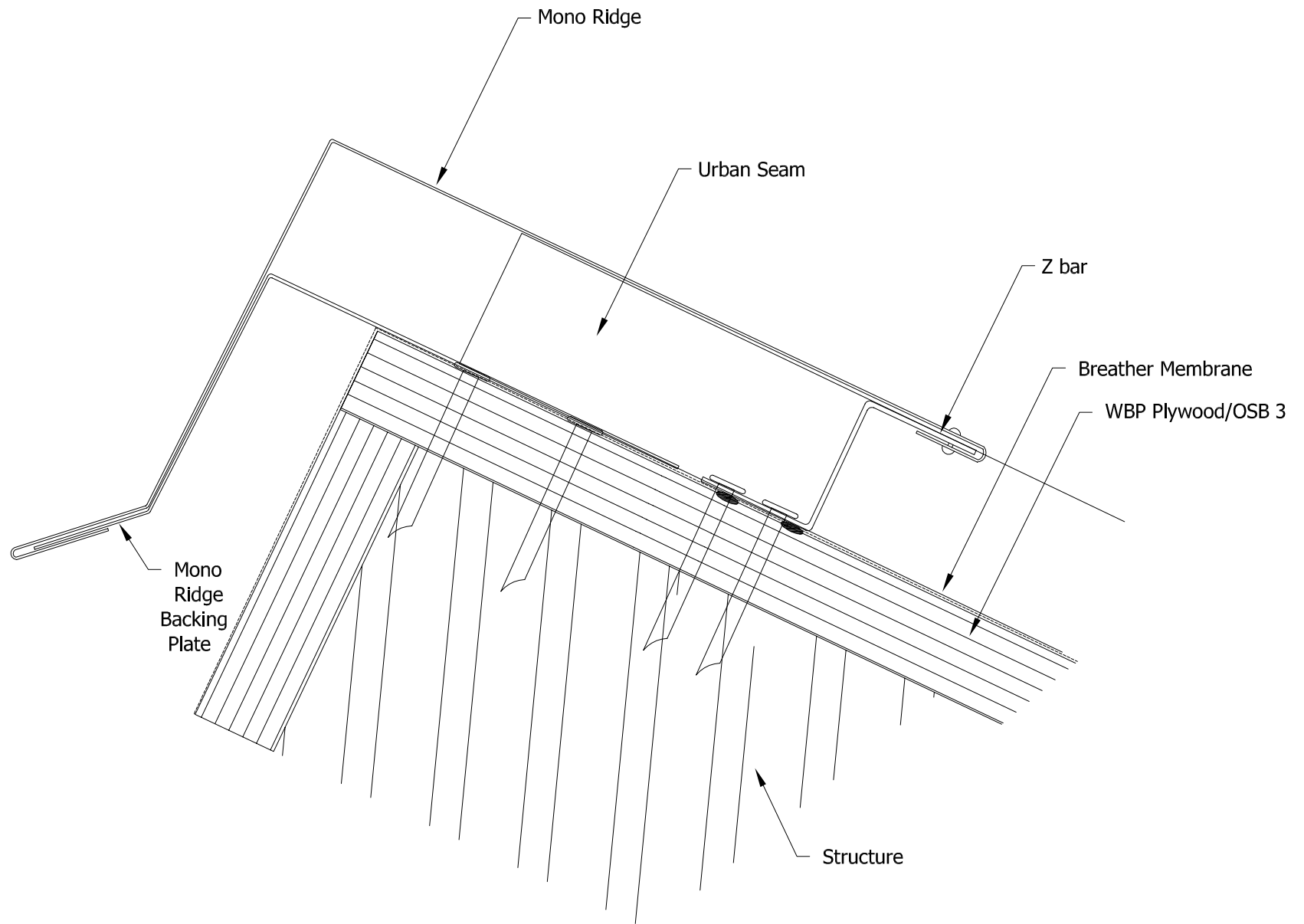

This drawing is the exclusive property of Tata Steel must not be copied or otherwise reproduced in anyway whatsoever without the express consent in writing of the corporation. The contents of the drawing must be treated as strictly confidential and must not be disclosed to any third party without the express consent in writing of the corporation.

Title

Mono Ridge

Drawing No.

ASU04

Scale : N/A

Copyright - Tata Steel © 2012

Rev: O

Colorcoat Urban
Shotton Works
Deeside
CH5 2NH

Tel: +44 (0)1244 89 2449
Fax: +44 (0)1244 89 2442
www.colorcoaturban.com

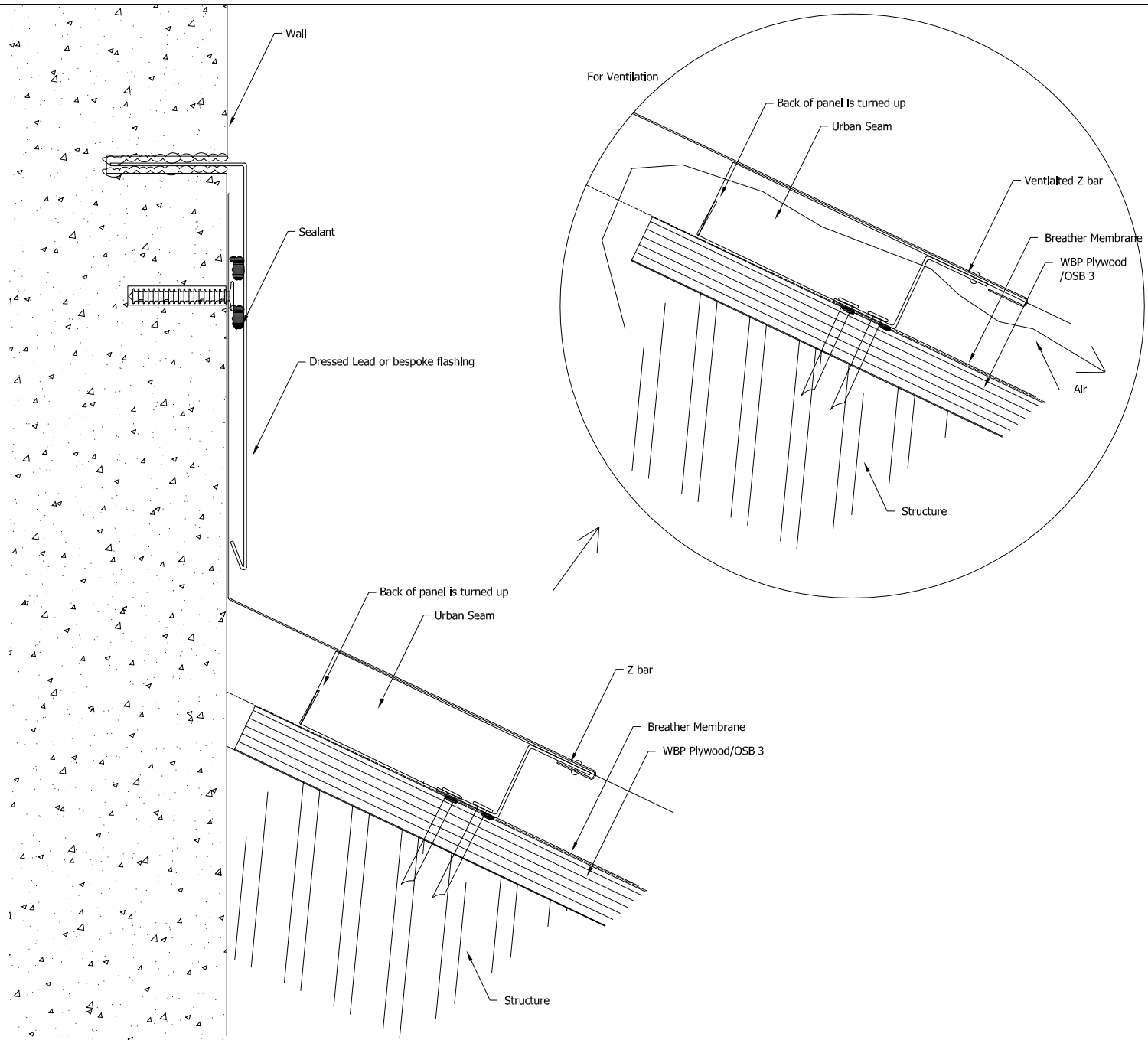

This drawing is the exclusive property of Tata Steel must not be copied or otherwise reproduced in anyway whatsoever without the express consent in writing of the corporation. The contents of the drawing must be treated as strictly confidential and must not be disclosed to any third party without the express consent in writing of the corporation.

Title

Top Abutment

Drawing No.

ASU05

Scale : N/A

Copyright - Tata Steel © 2012

Rev: O

Colorcoat Urban
Shotton Works
Deeside
CH5 2NH

Tel: +44 (0)1244 89 2449
Fax: +44 (0)1244 89 2442
www.colorcoaturban.com

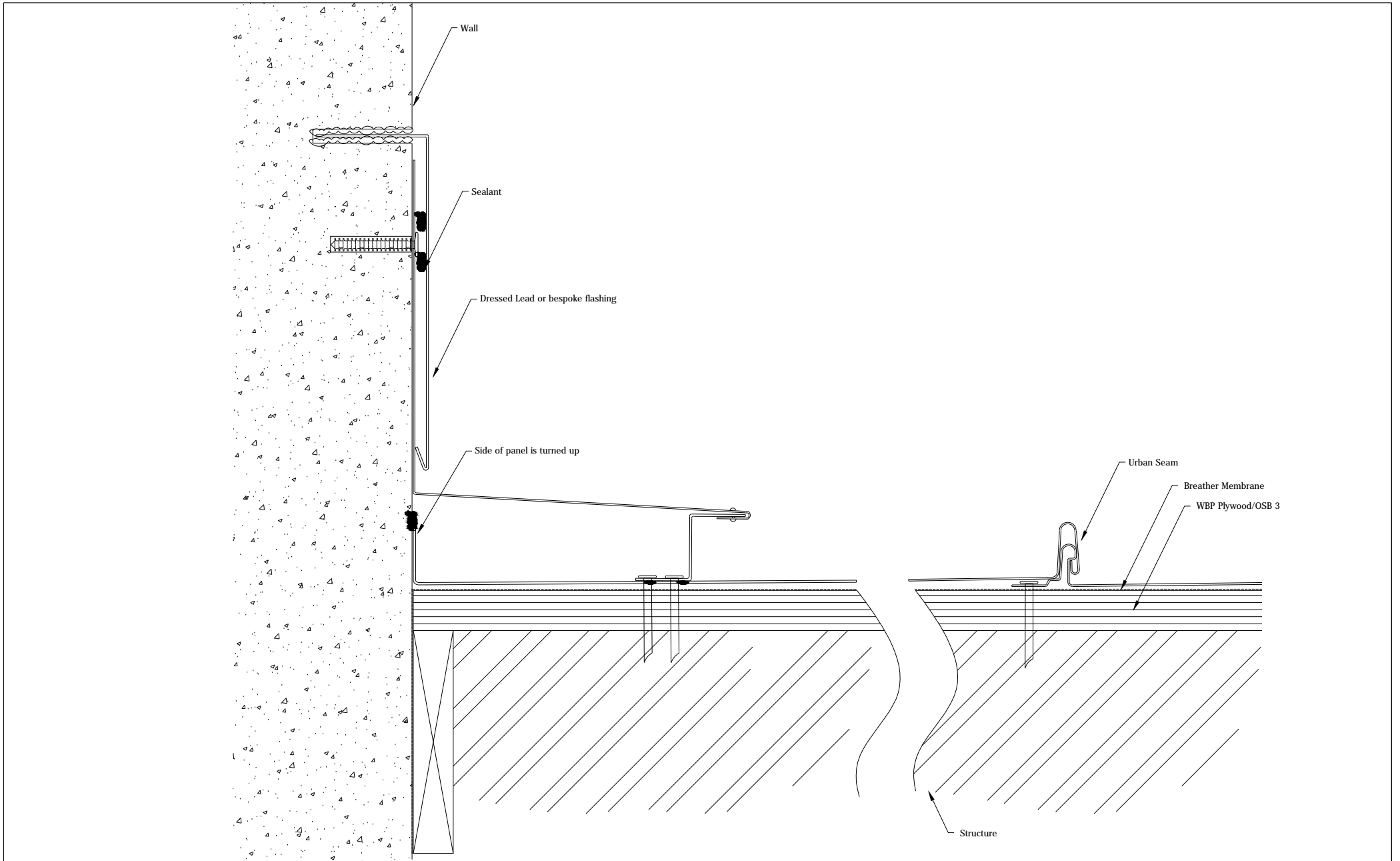

This drawing is the exclusive property of Tata Steel must not be copied or otherwise reproduced in anyway whatsoever without the express consent in writing of the corporation. The contents of the drawing must be treated as strictly confidential and must not be disclosed to any third party without the express consent in writing of the corporation.

Title	Side Abutment
Drawing No.	ASU06

Scale : N/A
Rev: O

Copyright - Tata Steel 2012	
Colorcoat Urban Shotton Works Deeside CH5 2NH	Tel: +44 (0)1244 89 2449 Fax: +44 (0)1244 89 2442 www.colorcoaturban.com

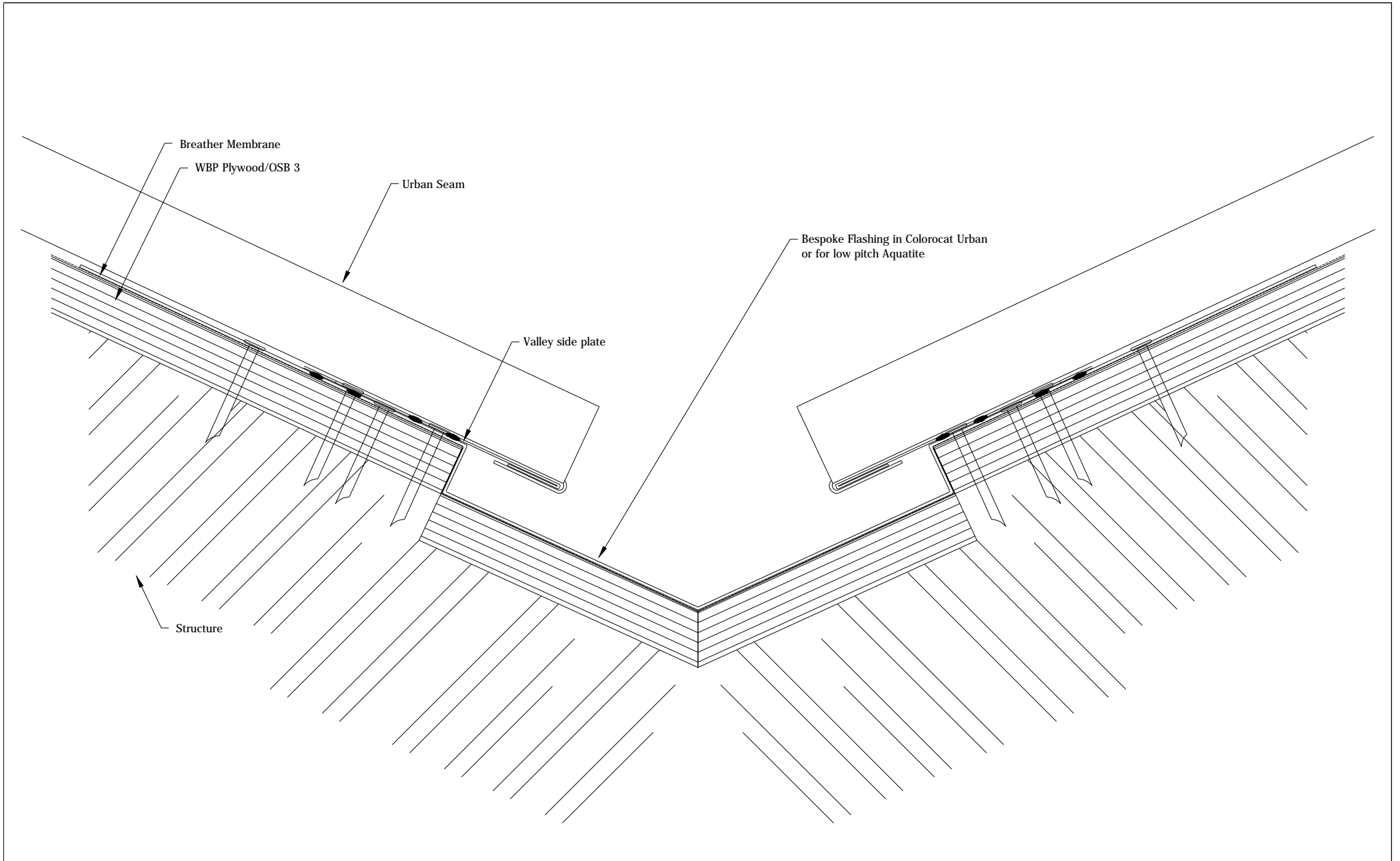

This drawing is the exclusive property of Tata Steel must not be copied or otherwise reproduced in anyway whatsoever without the express consent in writing of the corporation. The contents of the drawing must be treated as strictly confidential and must not be disclosed to any third party without the express consent in writing of the corporation.

Title	Valley
Drawing No.	ASU07

Scale : N/A
Rev: O

Copyright - Tata Steel ₹ 2012

Colorcoat Urban
Shotton Works
Deeside
CH5 2NH

Tel: +44 (0)1244 89 2449
Fax: +44 (0)1244 89 2442
www.colorcoaturban.com

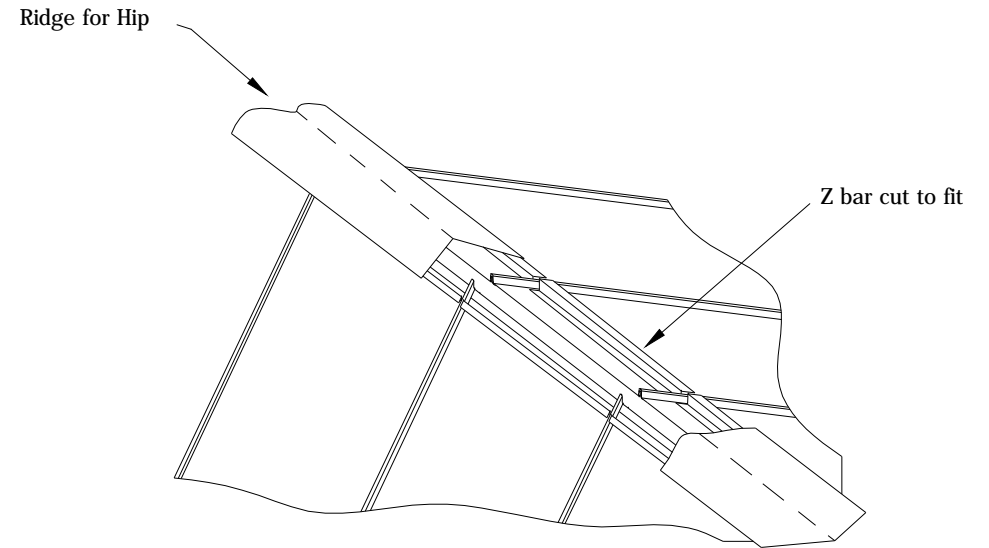
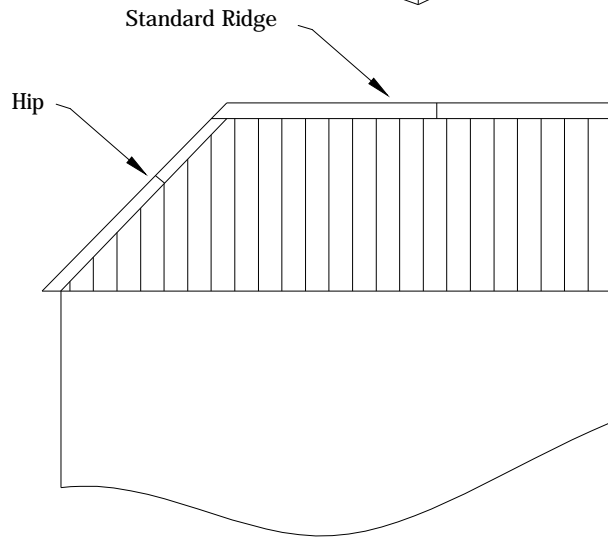
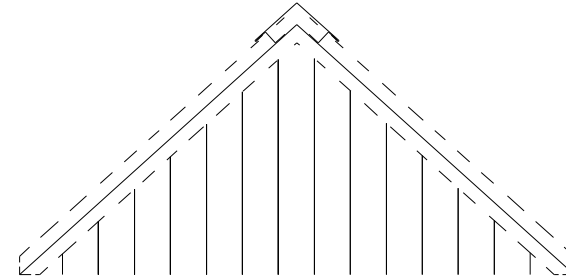
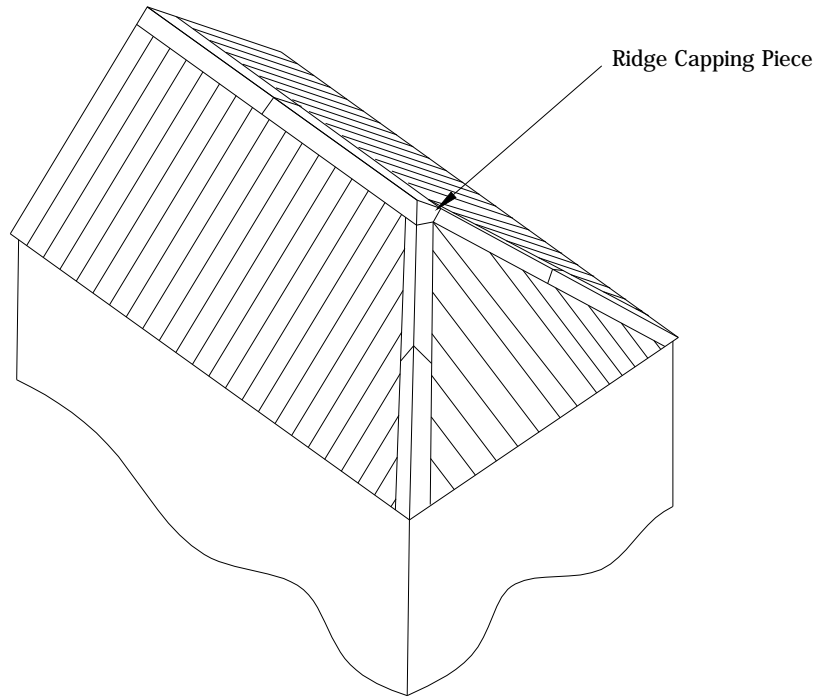

This drawing is the exclusive property of Tata Steel must not be copied or otherwise reproduced in anyway whatsoever without the express consent in writing of the corporation. The contents of the drawing must be treated as strictly confidential and must not be disclosed to any third party without the express consent in writing of the corporation.

Title	Hip
Drawing No.	ASU08

Scale : N/A
Rev: O

Copyright - Tata Steel 2012	
Colorcoat Urban Shotton Works Deeside CH5 2NH	Tel: +44 (0)1244 89 2449 Fax: +44 (0)1244 89 2442 www.colorcoaturban.com

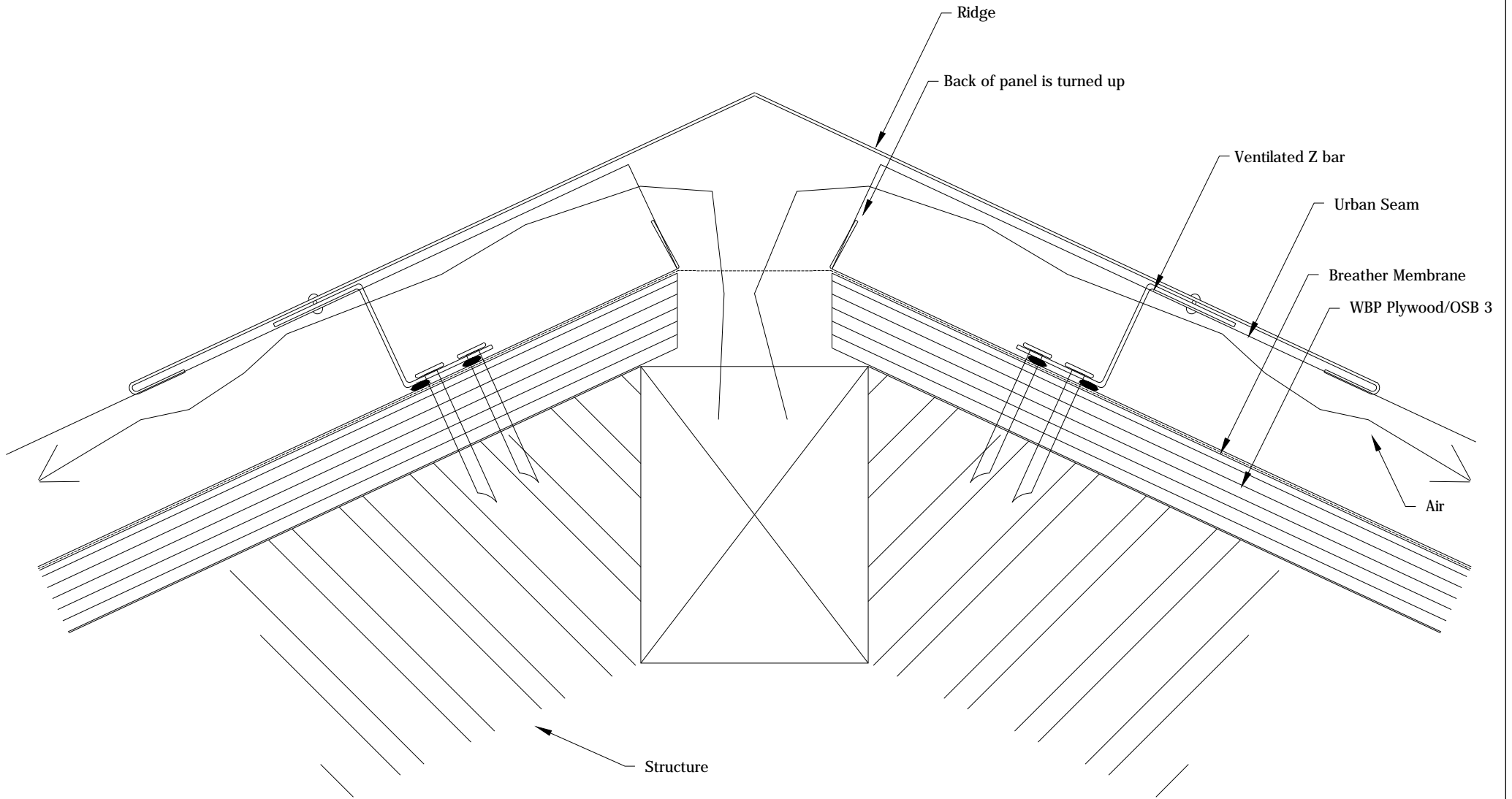

This drawing is the exclusive property of Tata Steel must not be copied or otherwise reproduced in anyway whatsoever without the express consent in writing of the corporation. The contents of the drawing must be treated as strictly confidential and must not be disclosed to any third party without the express consent in writing of the corporation.

Title	Ventilated Duo Ridge
Drawing No.	ASU010

Scale : N/A
Rev: 0

Copyright - Tata Steel 2012	
Colorcoat Urban Shotton Works Deeside CH5 2NH	Tel: +44 (0)1244 89 2449 Fax: +44 (0)1244 89 2442 www.colorcoaturban.com

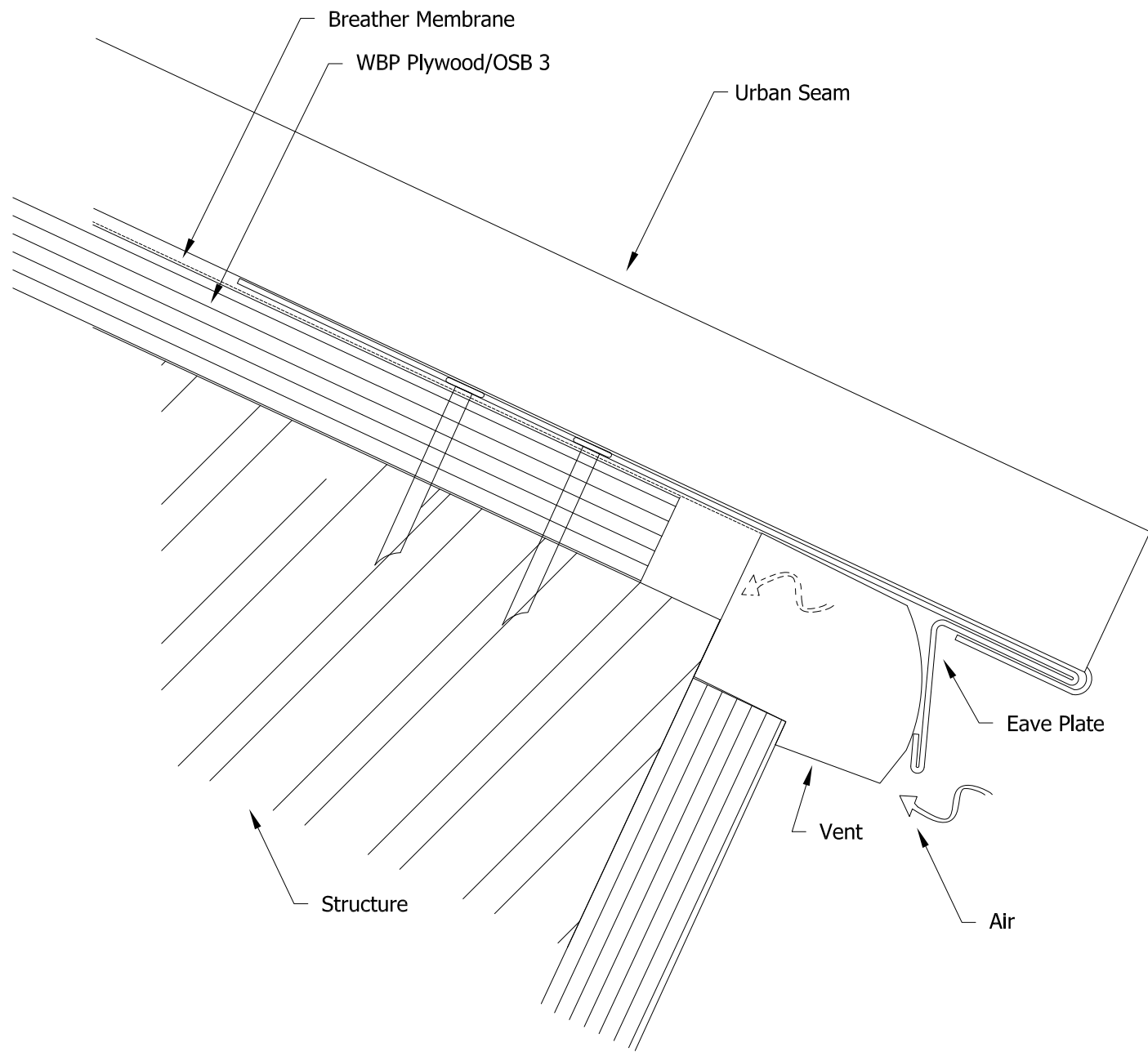

This drawing is the exclusive property of Tata Steel must not be copied or otherwise reproduced in anyway whatsoever without the express consent in writing of the corporation. The contents of the drawing must be treated as strictly confidential and must not be disclosed to any third party without the express consent in writing of the corporation.

Title

Ventilated Eave

Drawing No.

ASU011

Scale : N/A

Copyright - Tata Steel © 2012

Rev: O

Colorcoat Urban
Shotton Works
Deeside
CH5 2NH

Tel: +44 (0)1244 89 2449
Fax: +44 (0)1244 89 2442
www.colorcoaturban.com

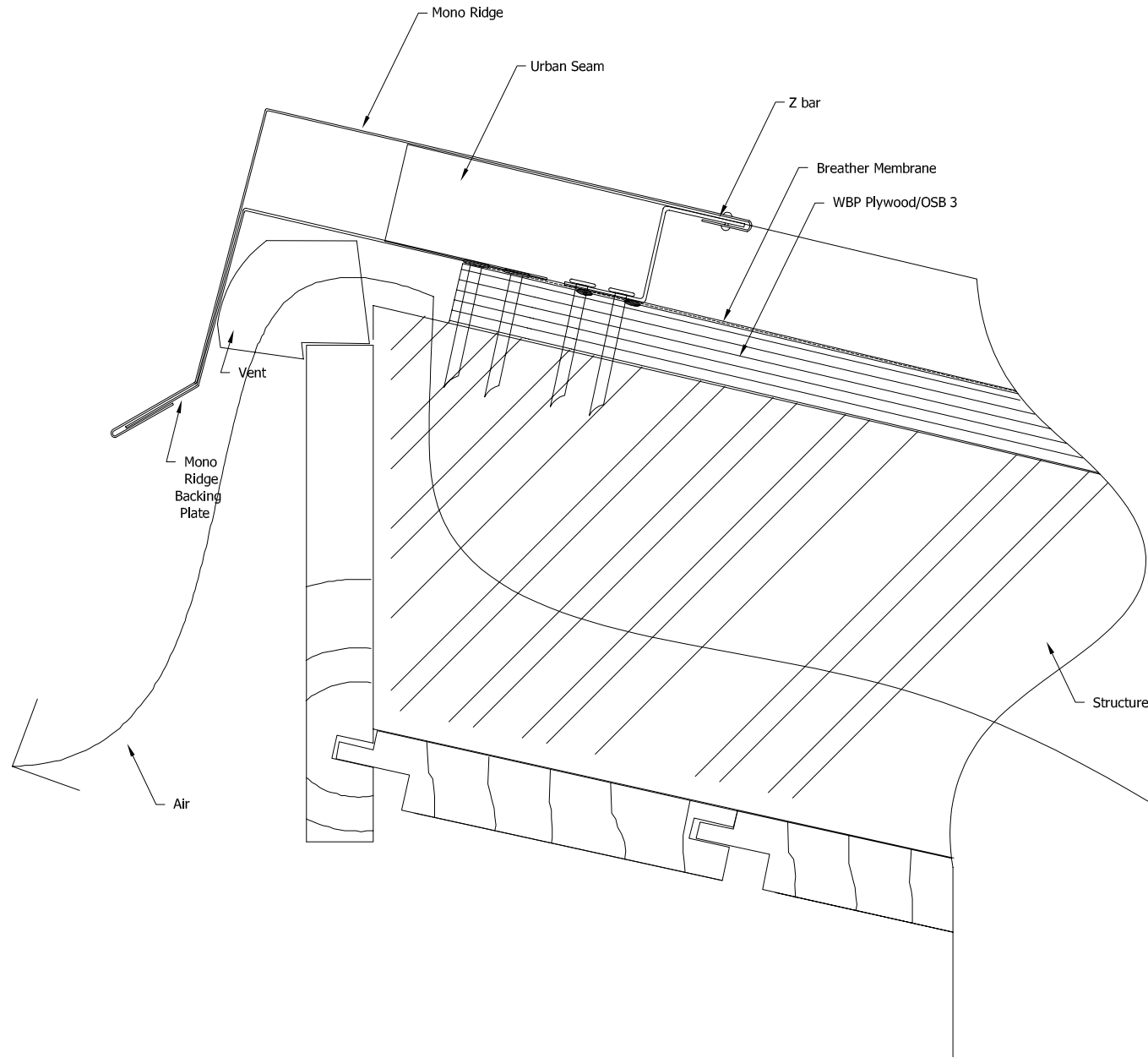

This drawing is the exclusive property of Tata Steel must not be copied or otherwise reproduced in anyway whatsoever without the express consent in writing of the corporation. The contents of the drawing must be treated as strictly confidential and must not be disclosed to any third party without the express consent in writing of the corporation.

Title

Ventilated Mono Ridge

Drawing No.

ASU012

Scale : N/A

Copyright - Tata Steel © 2012

Rev: O

Colorcoat Urban
Shotton Works
Deeside
CH5 2NH

Tel: +44 (0)1244 89 2449
Fax: +44 (0)1244 89 2442
www.colorcoaturban.com

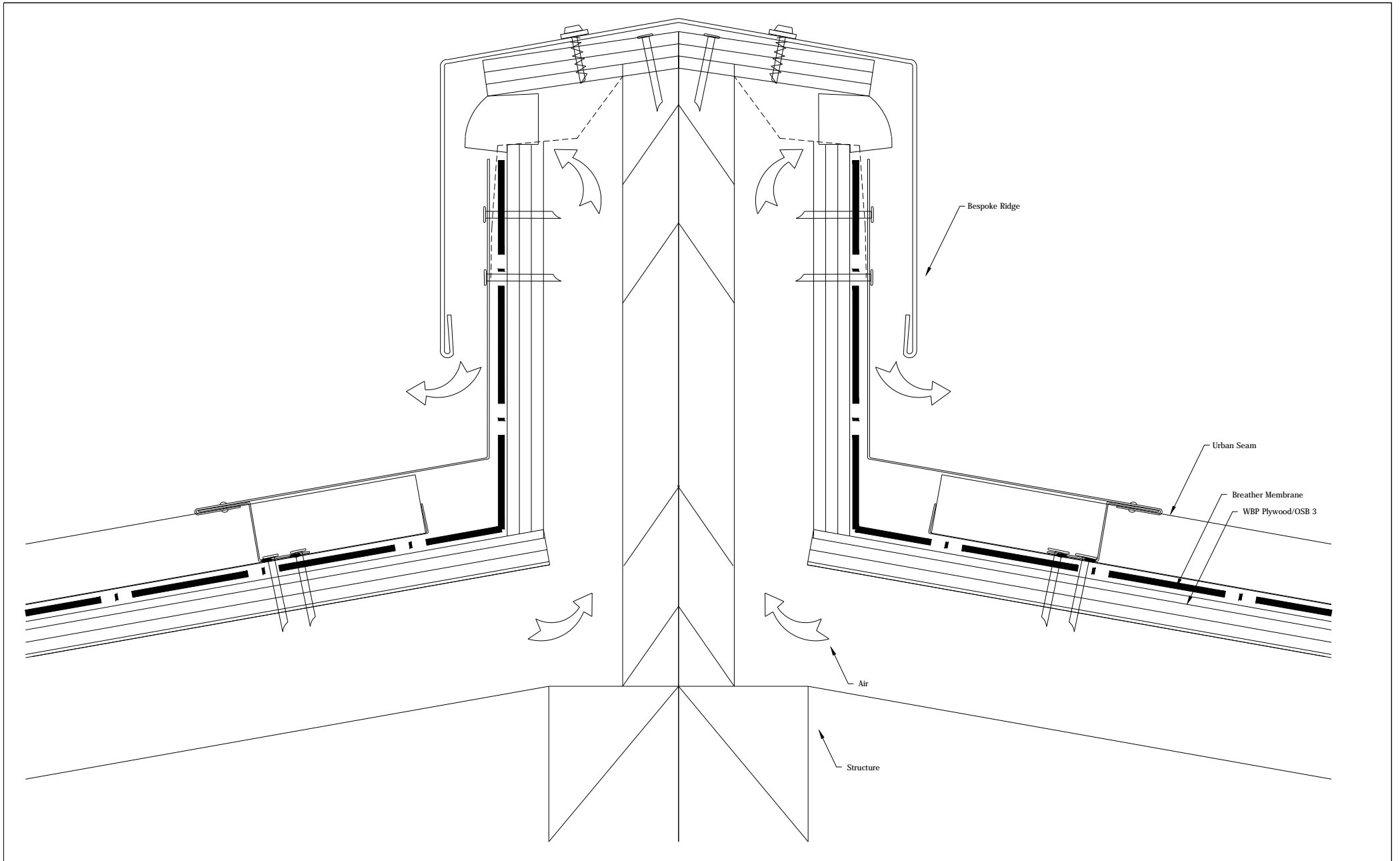

This drawing is the exclusive property of Tata Steel must not be copied or otherwise reproduced in anyway whatsoever without the express consent in writing of the corporation. The contents of the drawing must be treated as strictly confidential and must not be disclosed to any third party without the express consent in writing of the corporation.

Title	Ventilated Duo Ridge Low Pitch
Drawing No.	ASU013

Scale : N/A
Rev: 0

Copyright - Tata Steel 2012	
Colorcoat Urban Shotton Works Deeside CH5 2NH	Tel: +44 (0)1244 89 2449 Fax: +44 (0)1244 89 2442 www.colorcoaturban.com

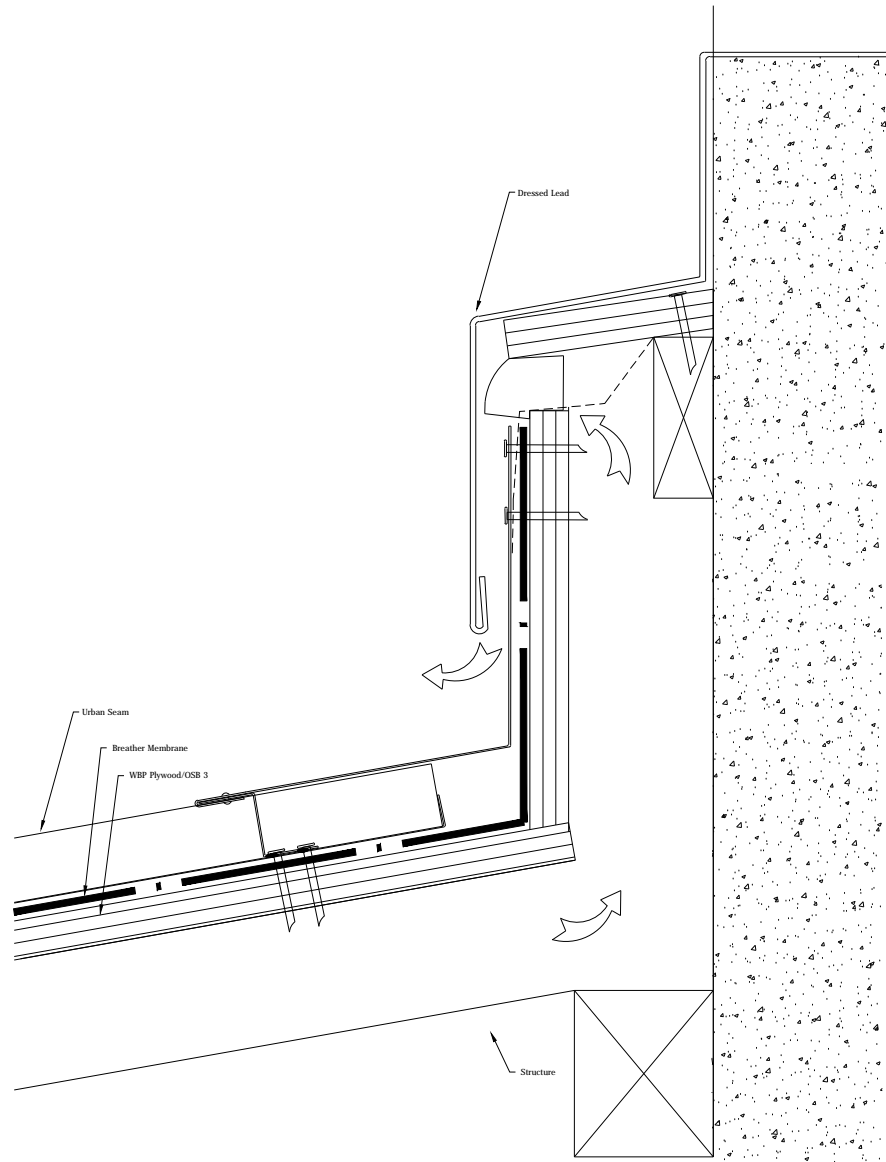

This drawing is the exclusive property of Tata Steel must not be copied or otherwise reproduced in anyway whatsoever without the express consent in writing of the corporation. The contents of the drawing must be treated as strictly confidential and must not be disclosed to any third party without the express consent in writing of the corporation.

Title

(Vent) Top Abutment Low Pitch

Drawing No.

ASU014

Scale : N/A

Copyright - Tata Steel 2012

Rev: 0

Colorcoat Urban
Shotton Works
Deeside
CH5 2NH

Tel: +44 (0)1244 89 2449
Fax: +44 (0)1244 89 2442
www.colorcoaturban.com

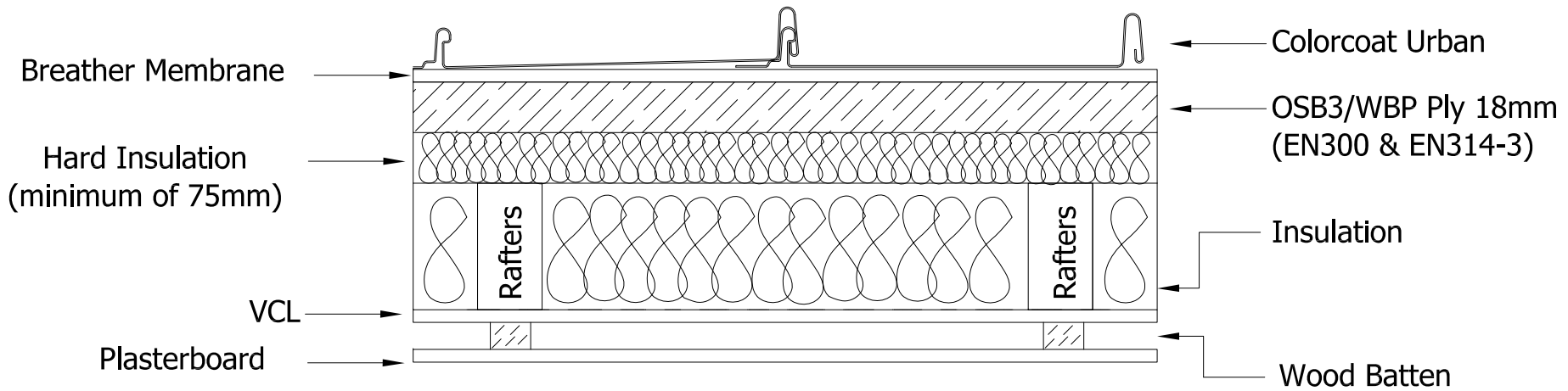
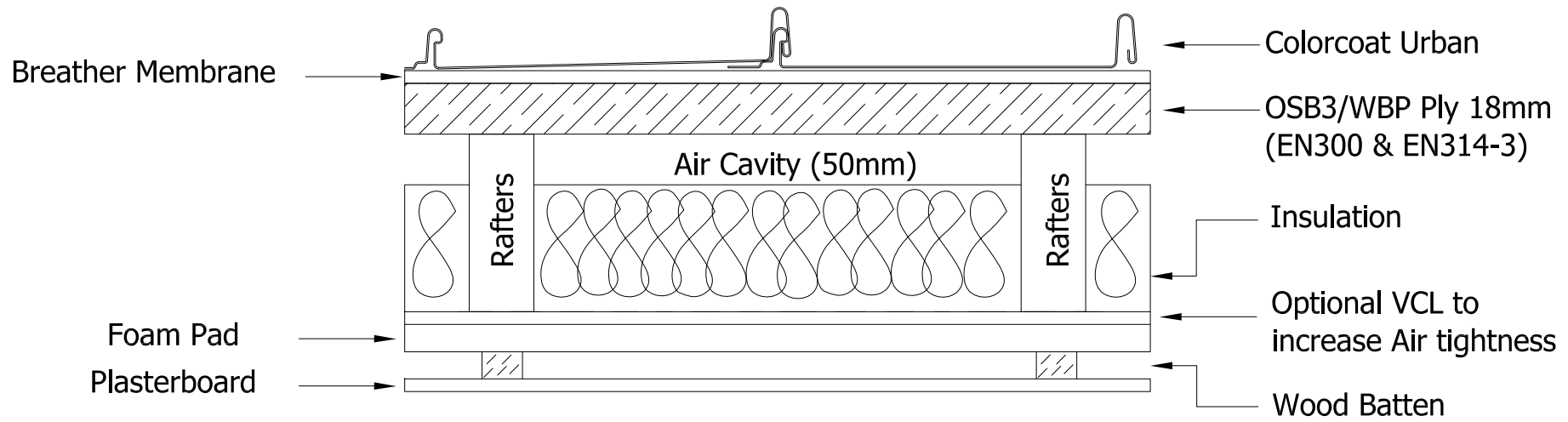

This drawing is the exclusive property of Tata Steel must not be copied or otherwise reproduced in anyway whatsoever without the express consent in writing of the corporation. The contents of the drawing must be treated as strictly confidential and must not be disclosed to any third party without the express consent in writing of the corporation.

Title	Roof Build Up Options
Drawing No.	ASU015

Scale : N/A	Copyright - Tata Steel © 2012		
Rev: 0	<table border="0"> <tr> <td>Colorcoat Urban Shotton Works Deeside CH5 2NH</td> <td>Tel: +44 (0)1244 89 2449 Fax: +44 (0)1244 89 2442 www.colorcoaturban.com</td> </tr> </table>	Colorcoat Urban Shotton Works Deeside CH5 2NH	Tel: +44 (0)1244 89 2449 Fax: +44 (0)1244 89 2442 www.colorcoaturban.com
Colorcoat Urban Shotton Works Deeside CH5 2NH	Tel: +44 (0)1244 89 2449 Fax: +44 (0)1244 89 2442 www.colorcoaturban.com		

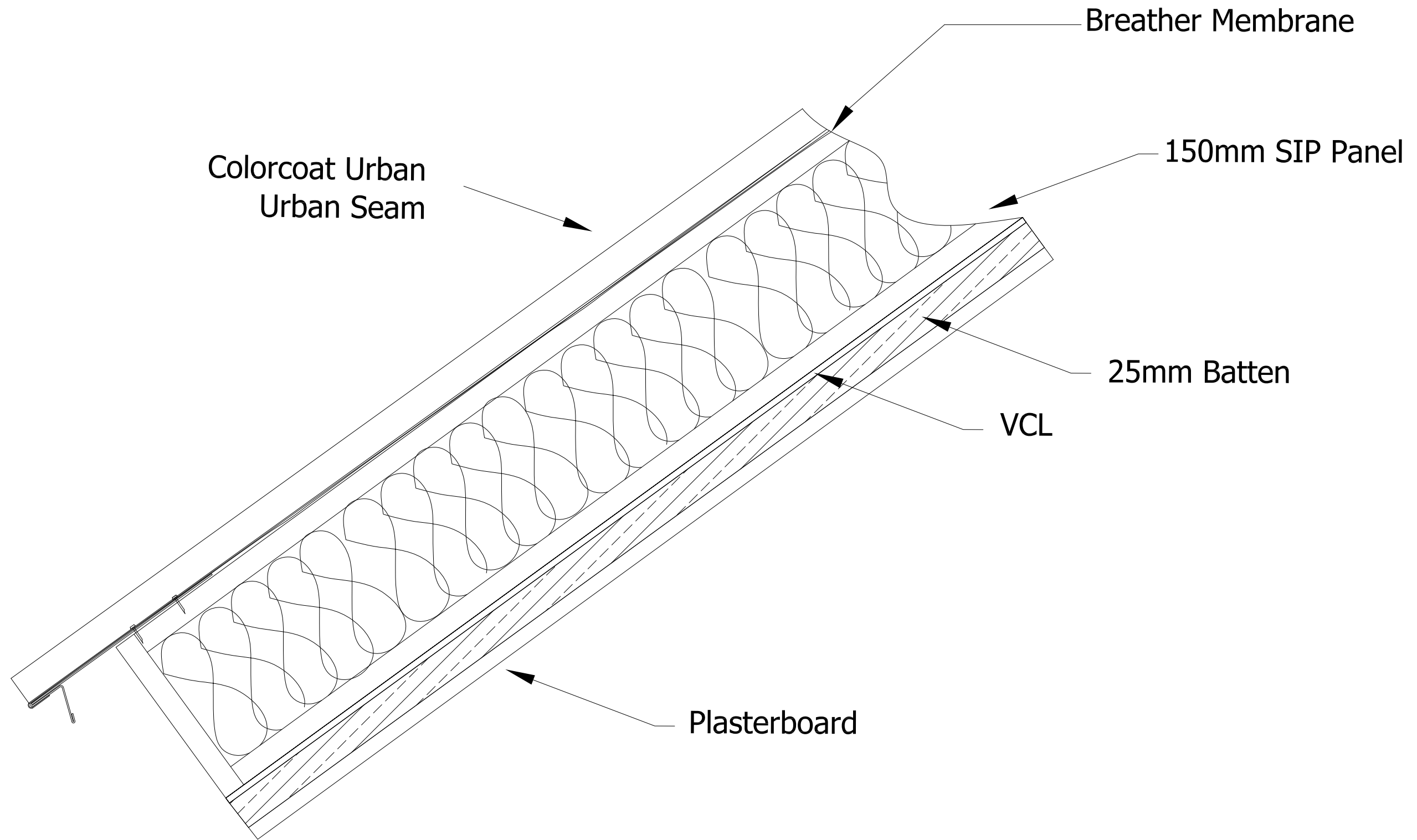

This drawing is the exclusive property of Tata Steel must not be copied or otherwise reproduced in anyway whatsoever without the express consent in writing of the corporation. The contents of the drawing must be treated as strictly confidential and must not be disclosed to any third party without the express consent in writing of the corporation.

Title

SIP Panel Build Up

Drawing No.

ASU017

Scale : N/A

Copyright - Tata Steel © 2012

Rev: 0

Colorcoat Urban
Shotton Works
Deeside
CH5 2NH

Tel: +44 (0)1244 89 2449
Fax: +44 (0)1244 89 2442
www.colorcoaturban.com

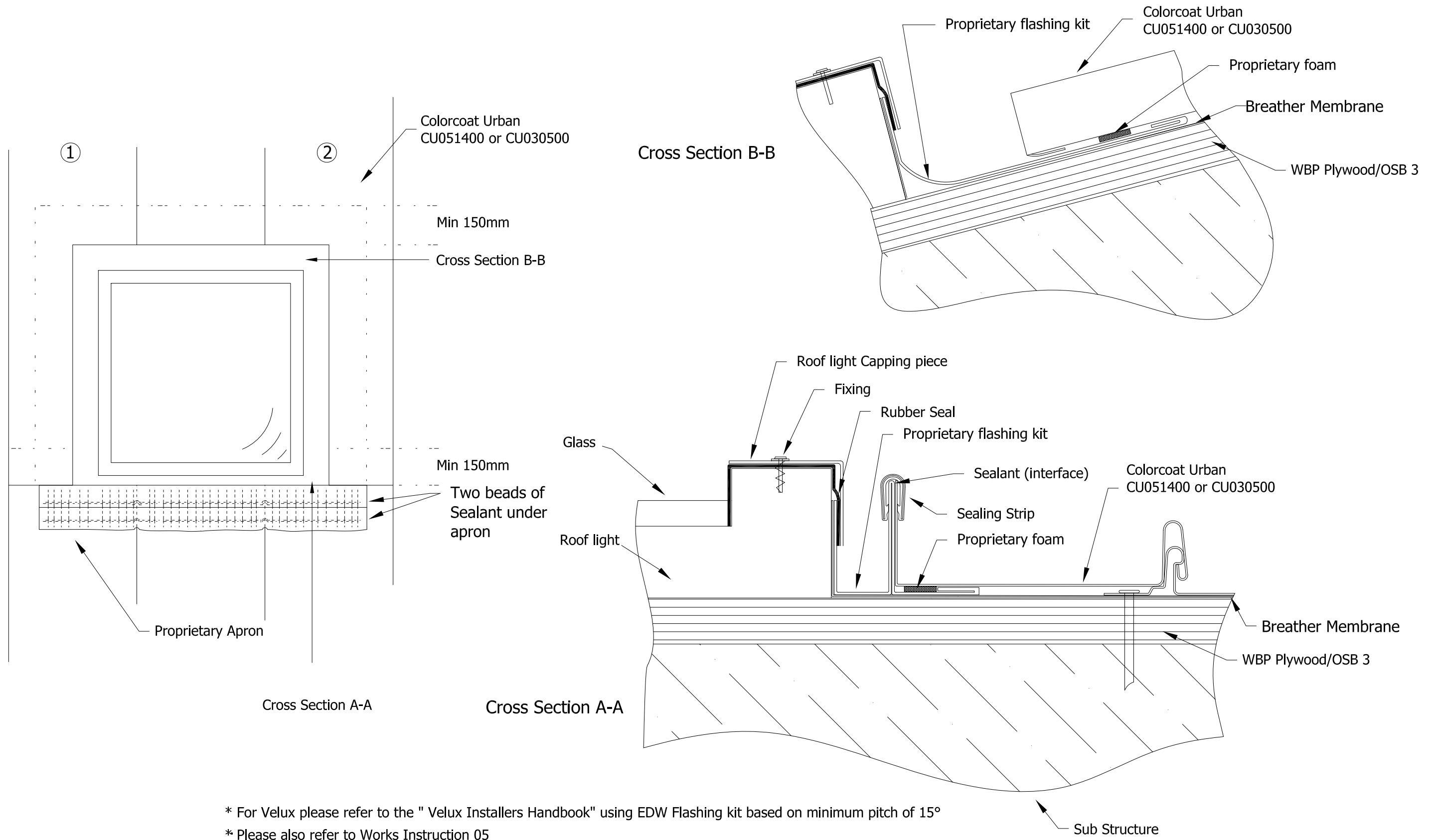

* For Velux please refer to the " Velux Installers Handbook" using EDW Flashing kit based on minimum pitch of 15°
 * Please also refer to Works Instruction 05
 * Panels 1 and 2 are made longer, for cutting and overlapping on site



This drawing is the exclusive property of Tata Steel must not be copied or otherwise reproduced in anyway whatsoever without the express consent in writing of the corporation. The contents of the drawing must be treated as strictly confidential and must not be disclosed to any third party without the express consent in writing of the corporation.

Title	Window Detail (Roof Lights)
Drawing No.	ASU020

Scale : N/A
Rev: 0

Copyright - Tata Steel © 2012	
Colorcoat Urban Shotton Works Deeside CH5 2NH	Tel: +44 (0)1244 89 2449 Fax: +44 (0)1244 89 2442 www.colorcoaturban.com

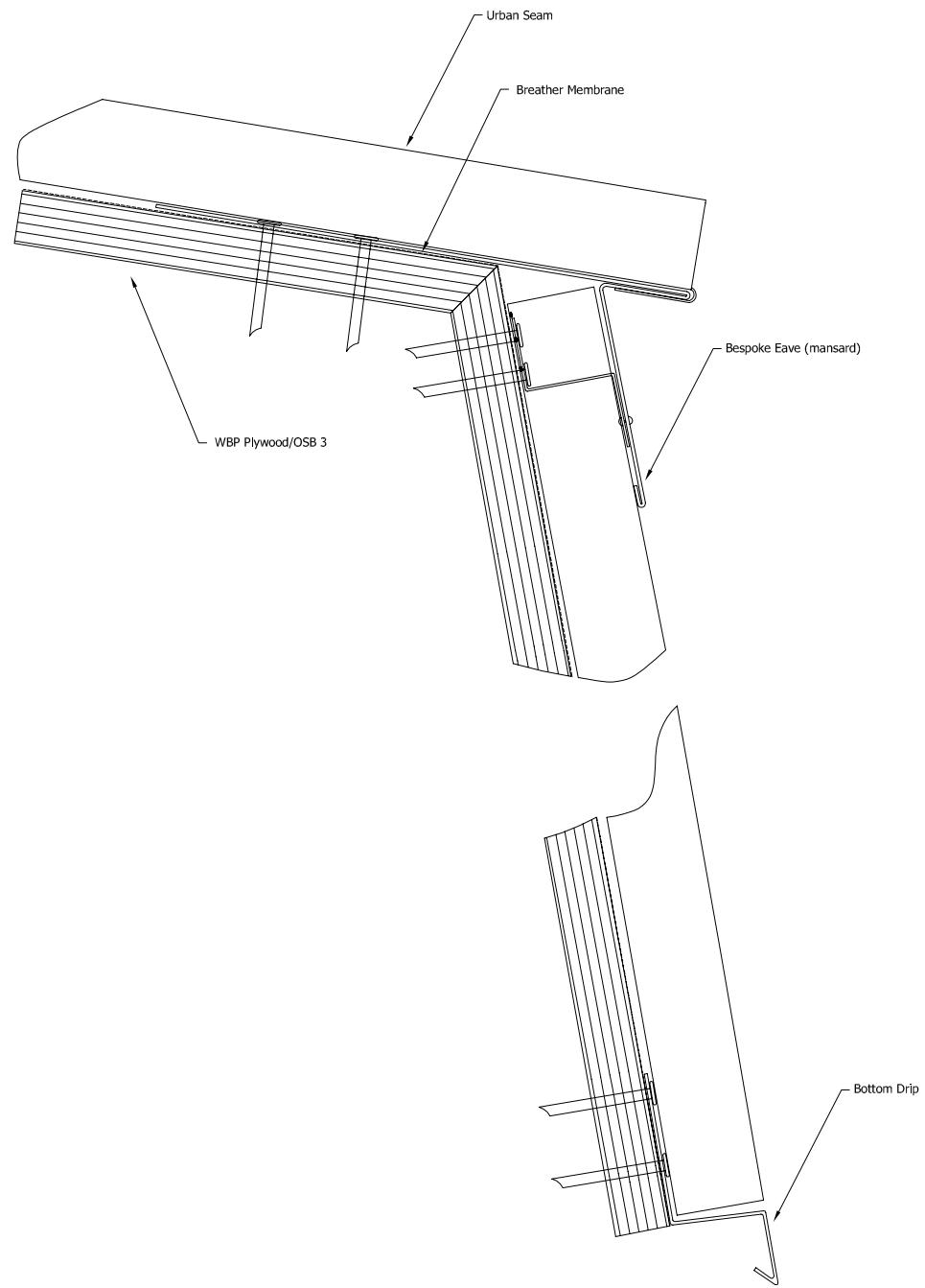

This drawing is the exclusive property of Tata Steel must not be copied or otherwise reproduced in anyway whatsoever without the express consent in writing of the corporation. The contents of the drawing must be treated as strictly confidential and must not be disclosed to any third party without the express consent in writing of the corporation.

Title

Mansard Detail

Drawing No.

ASU021

Scale : N/A

Copyright - Tata Steel © 2012

Rev: O

Colorcoat Urban
Shotton Works
Deeside
CH5 2NH

Tel: +44 (0)1244 89 2449
Fax: +44 (0)1244 89 2442
www.colorcoaturban.com

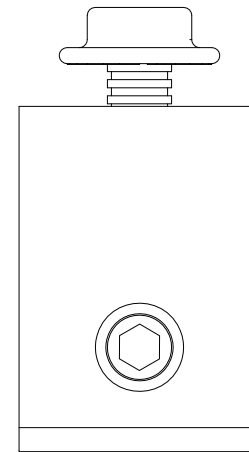
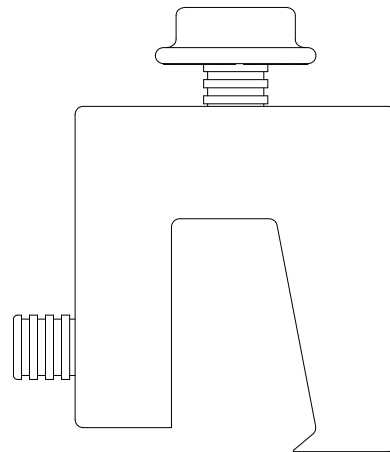
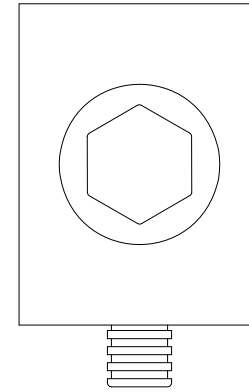
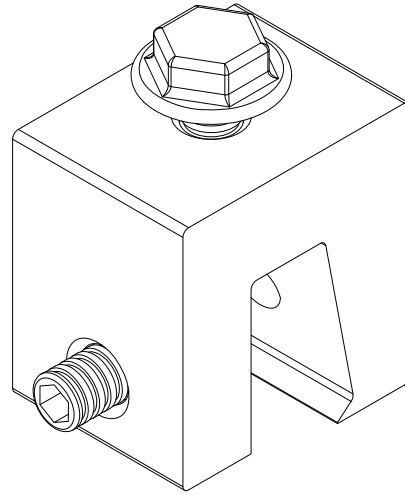

This drawing is the exclusive property of Tata Steel must not be copied or otherwise reproduced in anyway whatsoever without the express consent in writing of the corporation. The contents of the drawing must be treated as strictly confidential and must not be disclosed to any third party without the express consent in writing of the corporation.

Title

Fixing Clamp

Drawing No.

ASU022

Scale : N/A

Copyright - Tata Steel © 2012

Rev: 0

Colorcoat Urban
Shotton Works
Deeside
CH5 2NH

Tel: +44 (0)1244 89 2449
Fax: +44 (0)1244 89 2442
www.colorcoaturban.com

Urban Clamp

The urban clamp has been specially designed for Colorcoat Urban® seam profile. When attaching the clamps they are designed to engage with the seam as shown. For horizontal seam applications, the set screw must be accessible from the top for tightening.

The setscrews are opposite the open (or overlap) side of the seam. Only one orientation is possible with the Urban clamp for it to engage with the seam correctly.

For the maximum holding strength, setscrews should be tensioned and re-tensioned as the seam material compresses.

Please use the Urban clamp responsibly! Please see the load test results below based on pulling load normal to seam. The user and/or installer of the Urban Clamp are responsible for all necessary engineering and design for the intended use of the Urban Clamp in any assembly or application.

Please note one M8 bolt and one set screw is supplied with every Urban Clamp.

Profile	Screw Tension (Nm)	Allowable (KNs)	Ultimate (KNs)
Urban Seam®	13	1.5	4.51

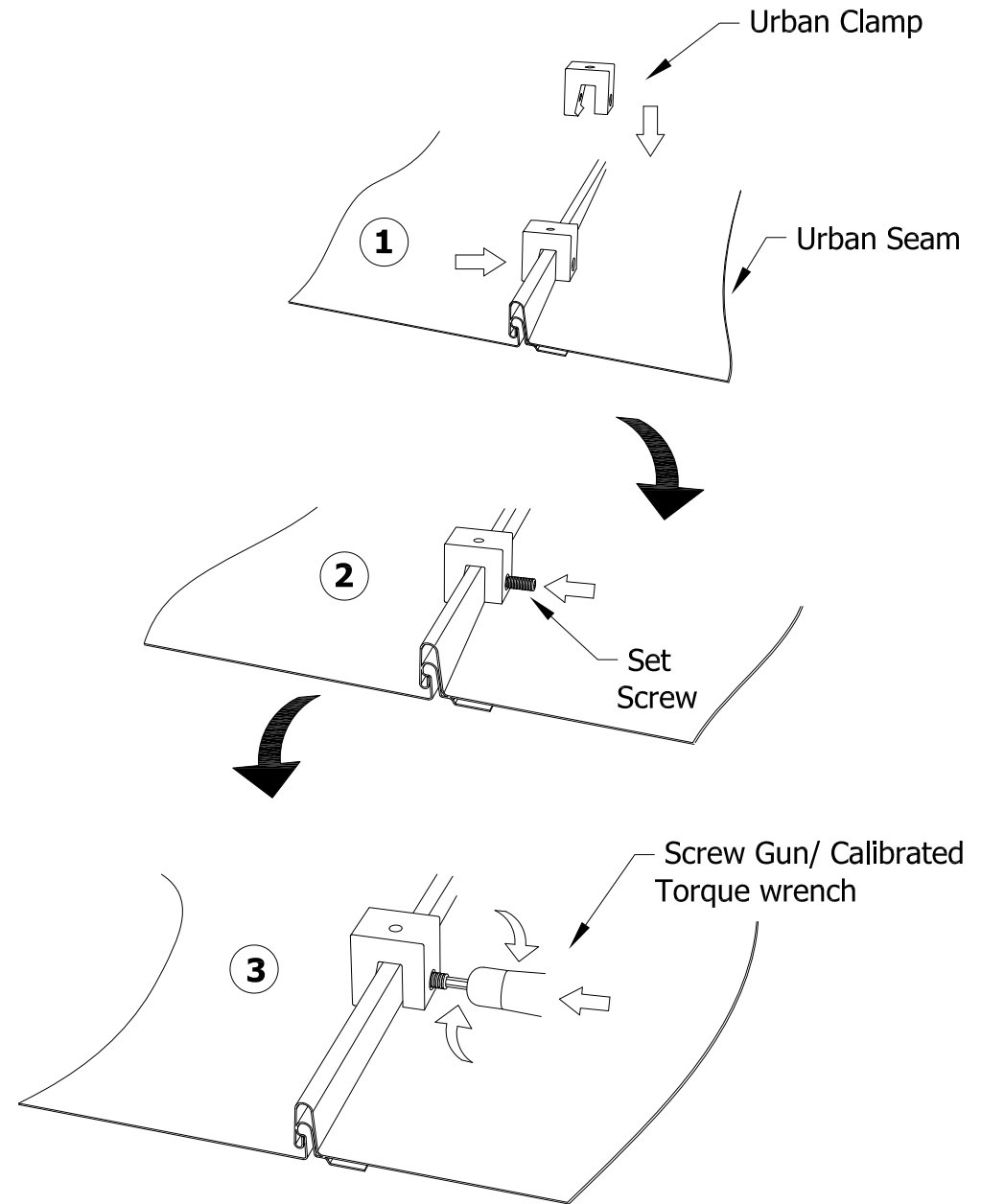
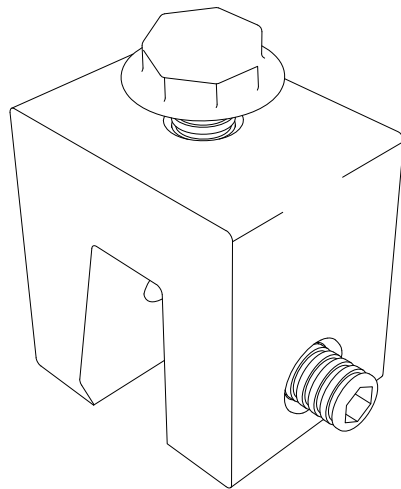

This drawing is the exclusive property of Tata Steel must not be copied or otherwise reproduced in anyway whatsoever without the express consent in writing of the corporation. The contents of the drawing must be treated as strictly confidential and must not be disclosed to any third party without the express consent in writing of the corporation.

Title

Urban Clamp Assembly

Drawing No.

ASU022 02

Scale : N/A

Copyright - Tata Steel © 2012

Rev: 0

Colorcoat Urban
Shotton Works
Deeside
CH5 2NH

Tel: +44 (0)1244 89 2449
Fax: +44 (0)1244 89 2442
www.colorcoaturban.com

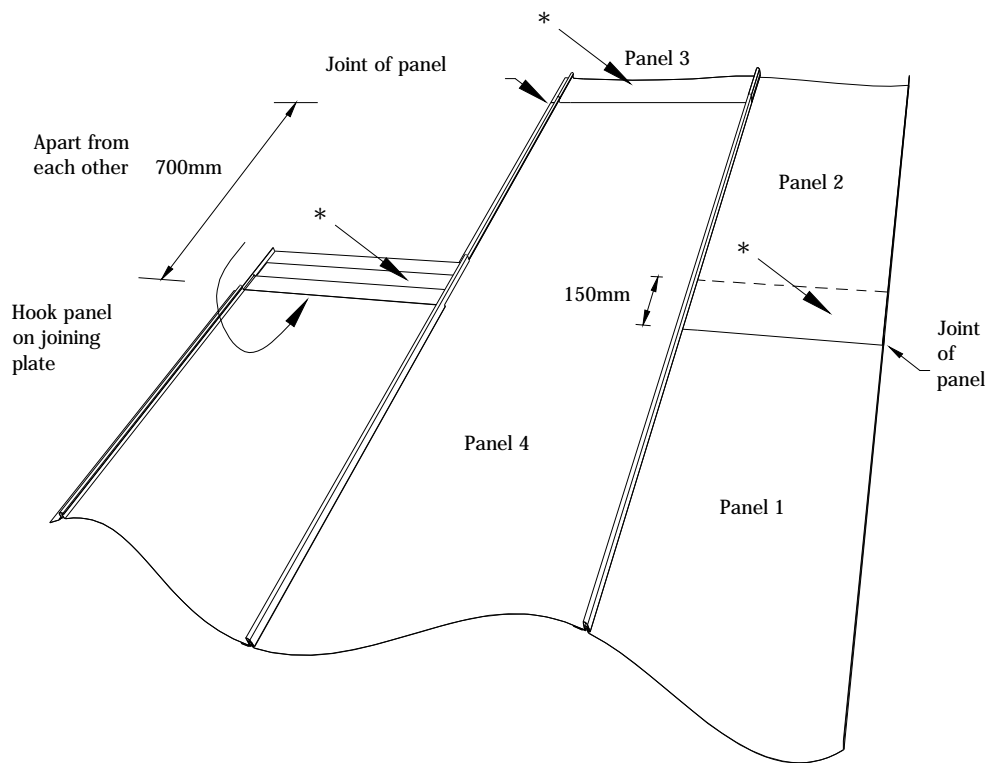

* Urban Seam on joining plate

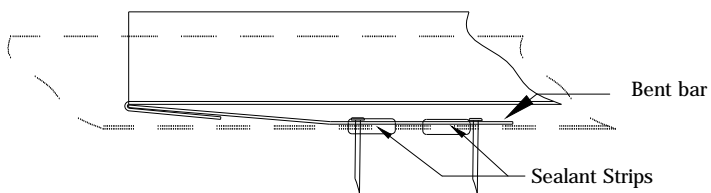

Panel 1 (top end)

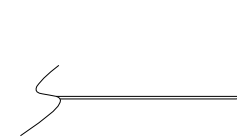
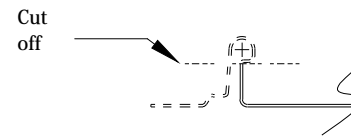

Panel 2

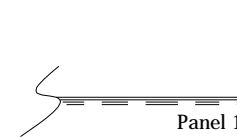

Panel 1 (top end)

Panel 3

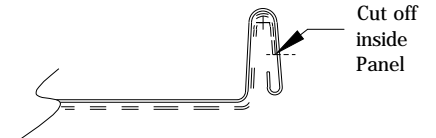

Panel 4 (top end)

Panel 4 (top end)

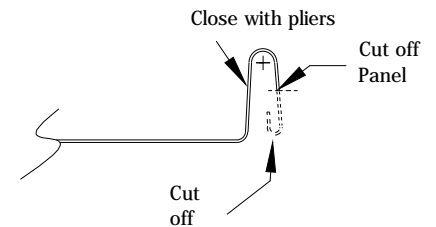
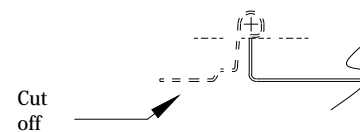

This drawing is the exclusive property of Tata Steel must not be copied or otherwise reproduced in anyway whatsoever without the express consent in writing of the corporation. The contents of the drawing must be treated as strictly confidential and must not be disclosed to any third party without the express consent in writing of the corporation.

Title

Joining Panels

Drawing No.

ASU023

Scale : N/A

Copyright - Tata Steel 2012

Rev: O

Colorcoat Urban
Shotton Works
Deeside
CH5 2NH

Tel: +44 (0)1244 89 2449
Fax: +44 (0)1244 89 2442
www.colorcoaturban.com

Flashing Layout

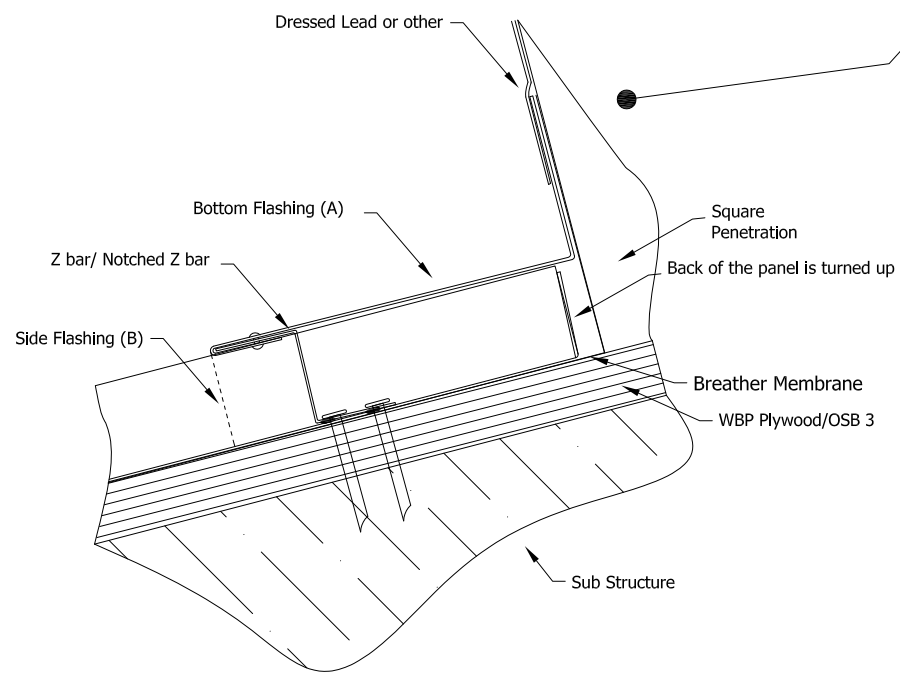
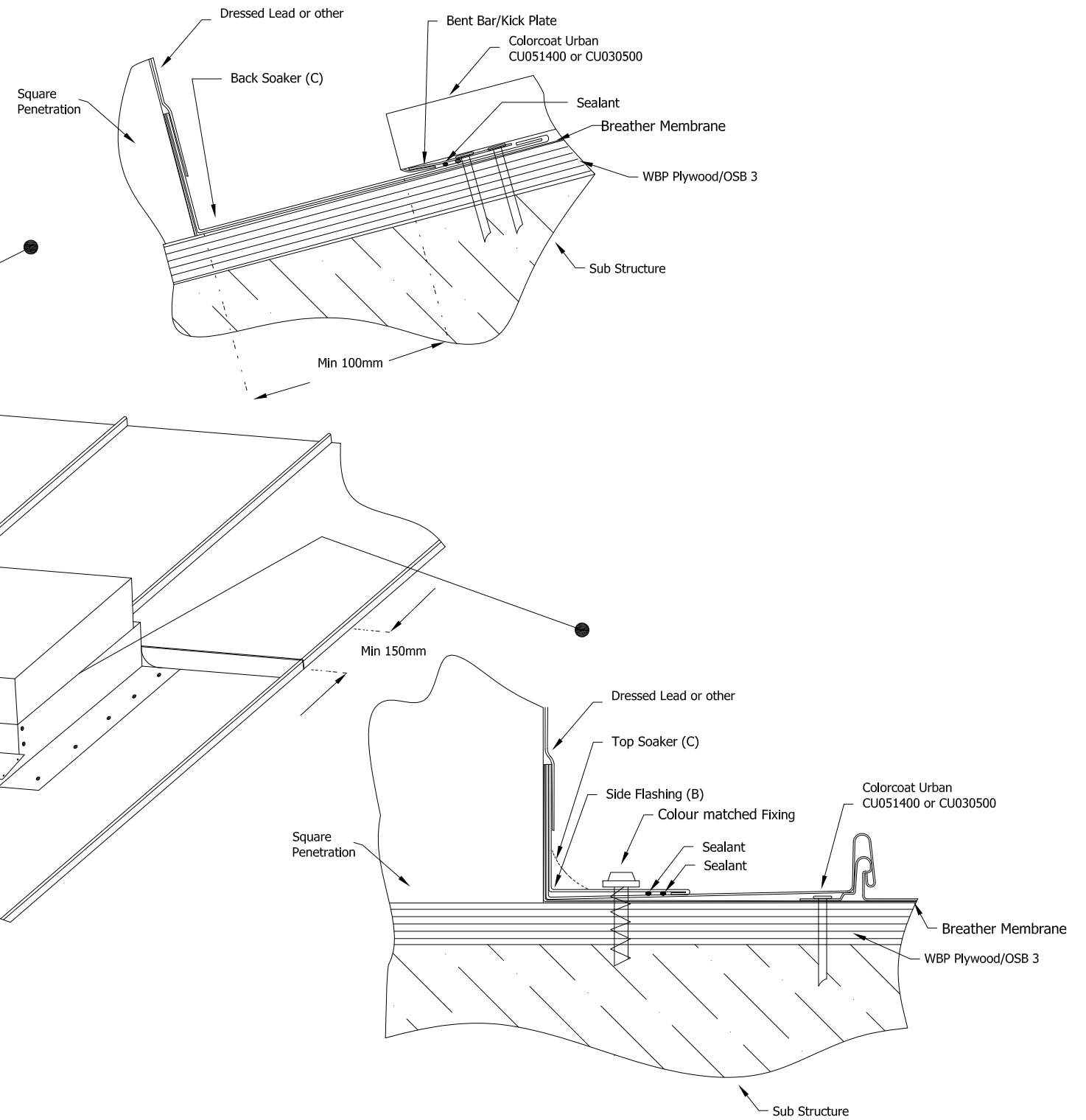
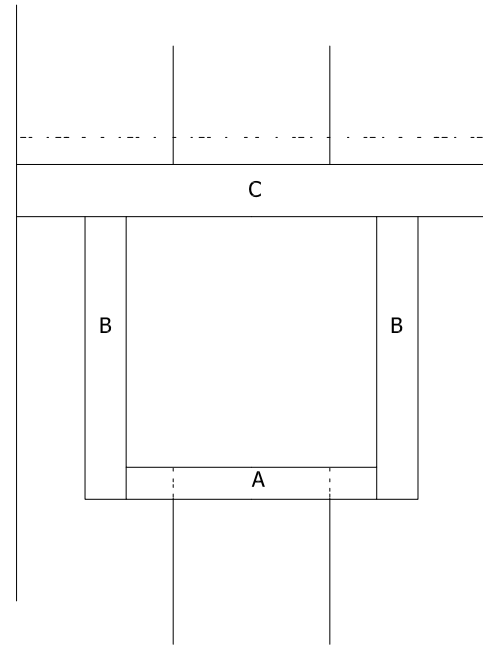

* Please refer to Works Instruction 04.



This drawing is the exclusive property of Tata Steel must not be copied or otherwise reproduced in anyway whatsoever without the express consent in writing of the corporation. The contents of the drawing must be treated as strictly confidential and must not be disclosed to any third party without the express consent in writing of the corporation.

Title

Square Penetration

Drawing No.

ASU024

Scale : N/A

Copyright - Tata Steel © 2012

Rev: 0

Colorcoat Urban
Shotton Works
Deeside
CH5 2NH

Tel: +44 (0)1244 89 2449
Fax: +44 (0)1244 89 2442
www.colorcoaturban.com

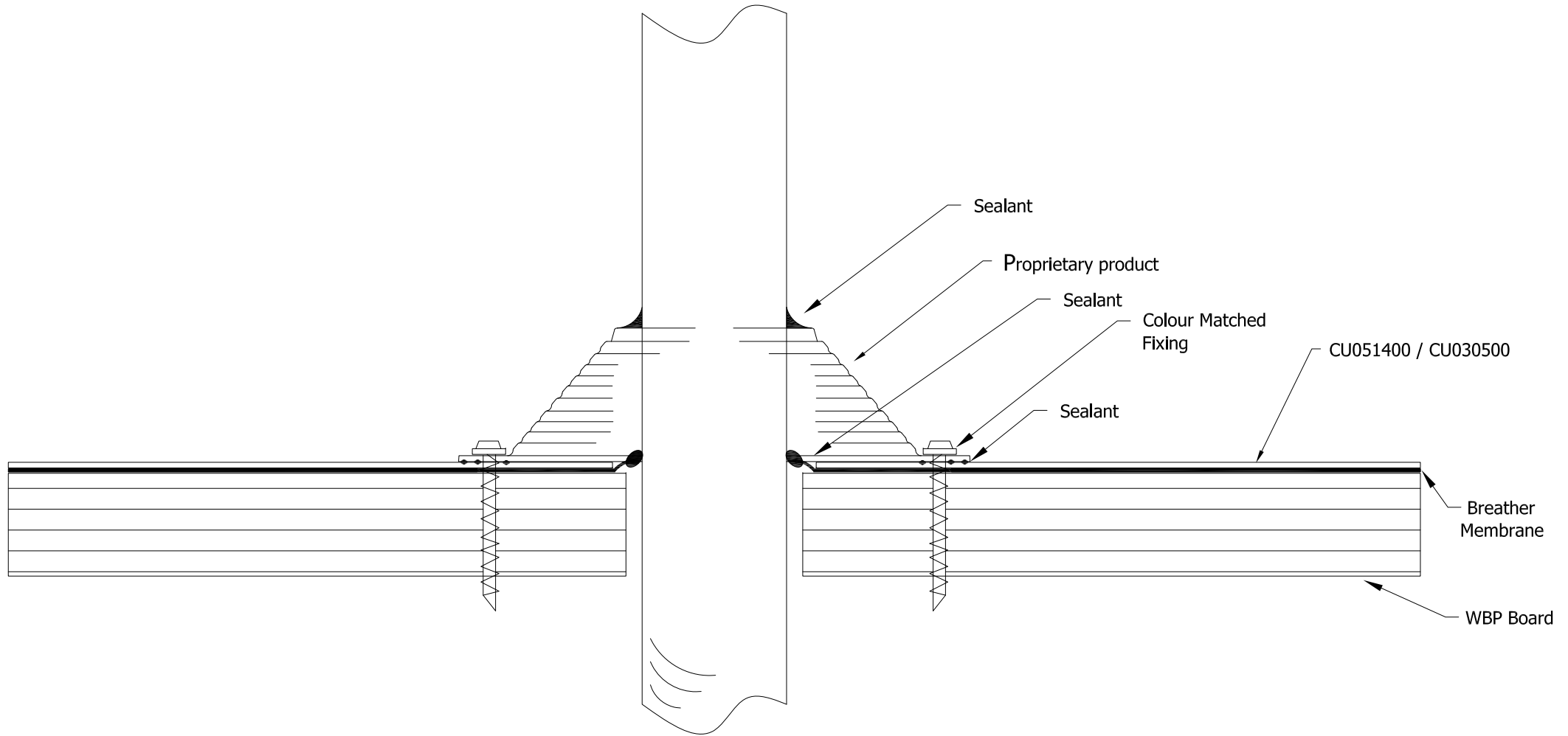

This drawing is the exclusive property of Tata Steel must not be copied or otherwise reproduced in anyway whatsoever without the express consent in writing of the corporation. The contents of the drawing must be treated as strictly confidential and must not be disclosed to any third party without the express consent in writing of the corporation.

Title

SVP or round Chimney

Drawing No.

ASU025

Scale : N/A

Copyright - Tata Steel © 2012

Rev: O

Colorcoat Urban
Shotton Works
Deeside
CH5 2NH

Tel: +44 (0)1244 89 2449
Fax: +44 (0)1244 89 2442
www.colorcoaturban.com

Mono Ridge

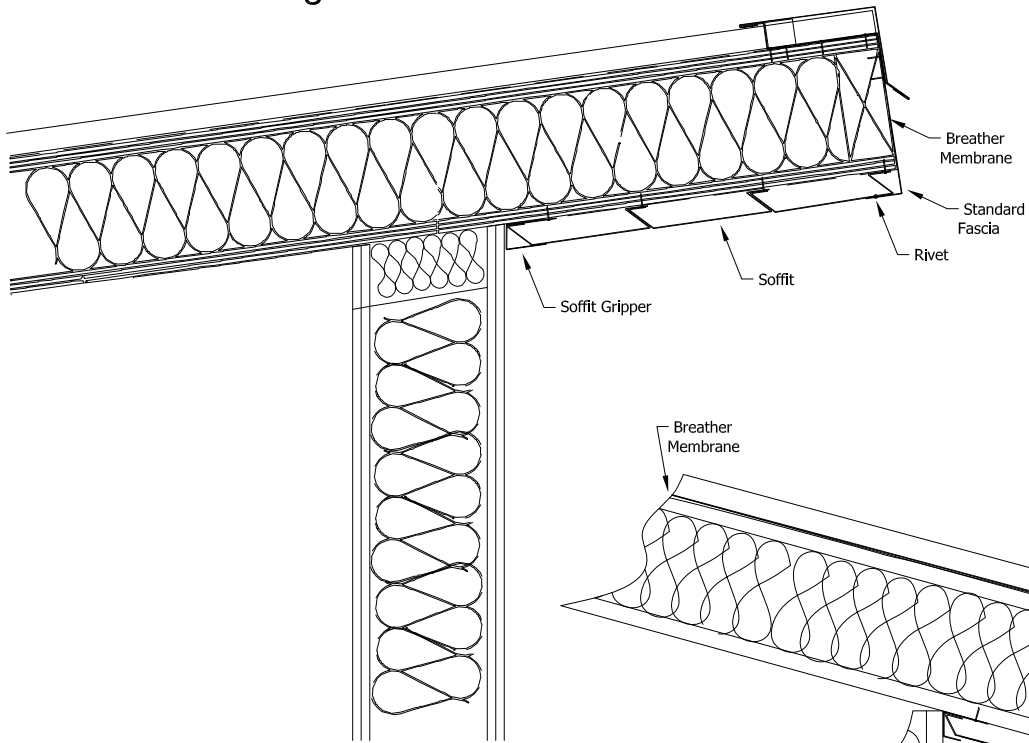

Verge

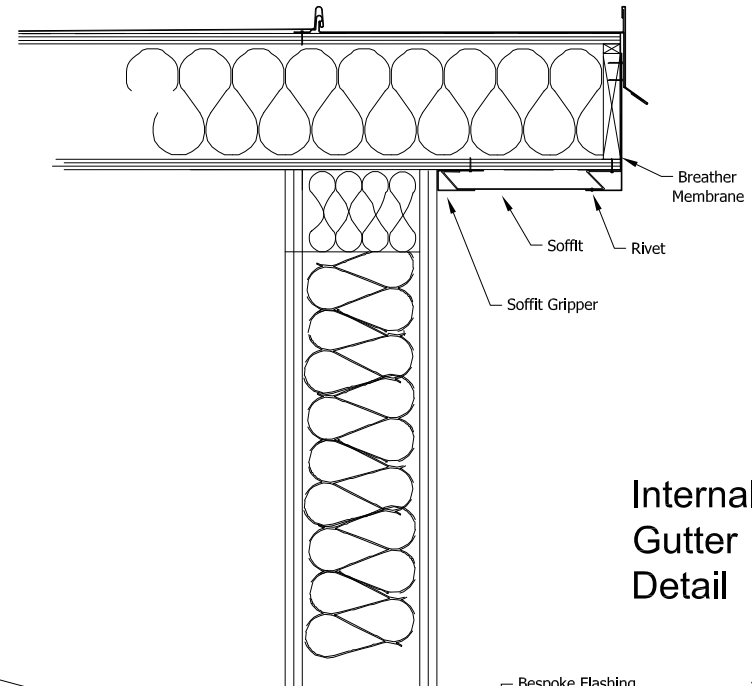

Eave

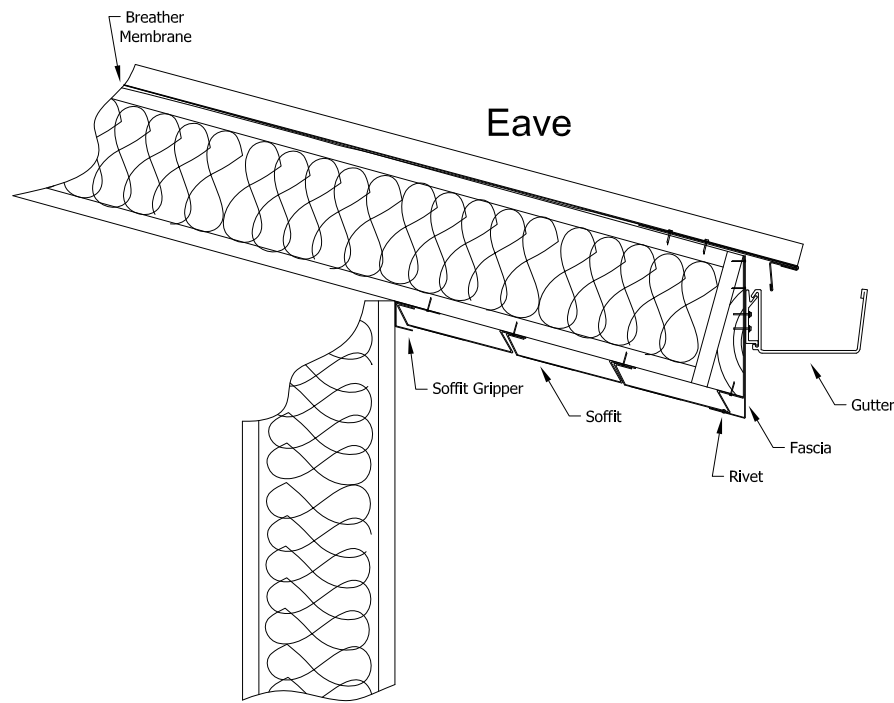

Internal Gutter Detail

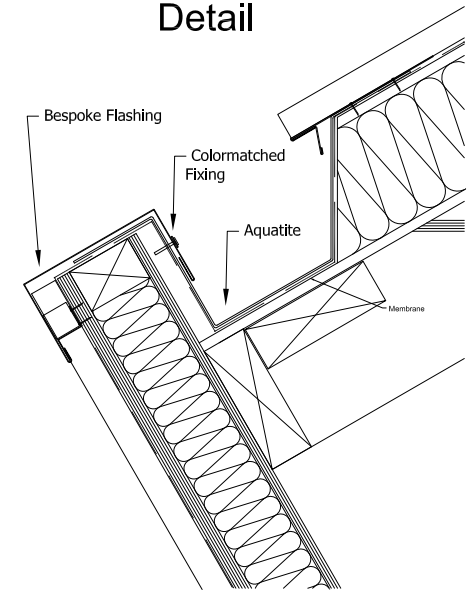

This drawing is the exclusive property of Tata Steel must not be copied or otherwise reproduced in anyway whatsoever without the express consent in writing of the corporation. The contents of the drawing must be treated as strictly confidential and must not be disclosed to any third party without the express consent in writing of the corporation.

Title

Fascia, Soffit and internal gutter

Drawing No.

ASU026

Scale : N/A

Copyright - Tata Steel © 2012

Rev: 0

Colorcoat Urban
Shotton Works
Deeside
CH5 2NH

Tel: +44 (0)1244 89 2449
Fax: +44 (0)1244 89 2442
www.colorcoaturban.com

OSB3/WBP Plywood

Fixing

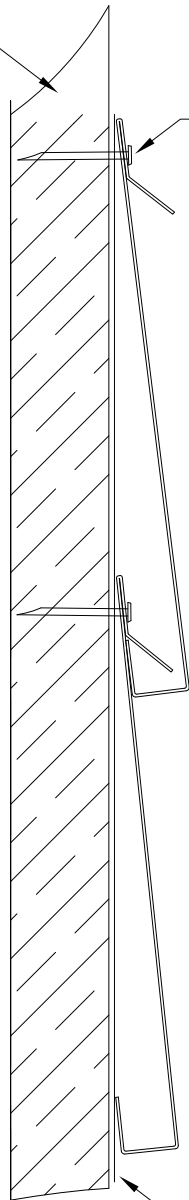

Breather Membrane

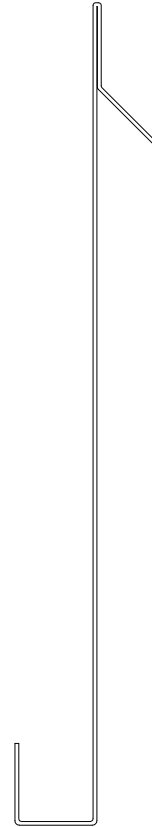

Variable Dimension

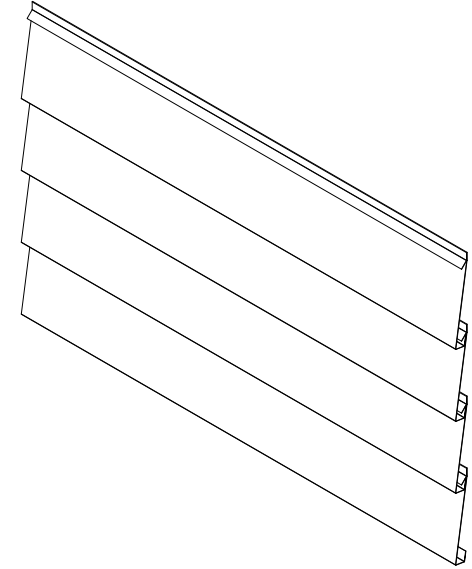

This drawing is the exclusive property of Tata Steel must not be copied or otherwise reproduced in anyway whatsoever without the express consent in writing of the corporation. The contents of the drawing must be treated as strictly confidential and must not be disclosed to any third party without the express consent in writing of the corporation.

Title

Weatherboard

Drawing No.

ASU027

Scale : N/A

Copyright - Tata Steel © 2012

Rev: O

Colorcoat Urban
Shotton Works
Deeside
CH5 2NH

Tel: +44 (0)1244 89 2449
Fax: +44 (0)1244 89 2442
www.colorcoaturban.com

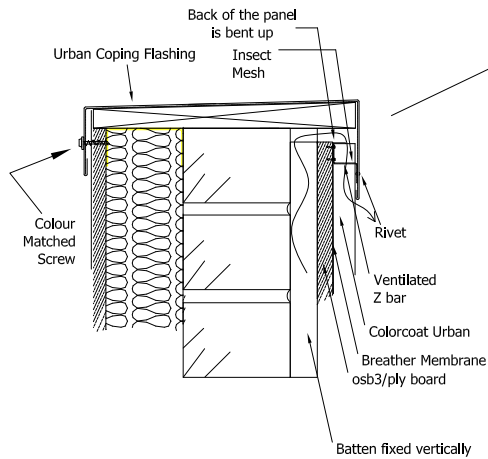

Batten fixed vertically

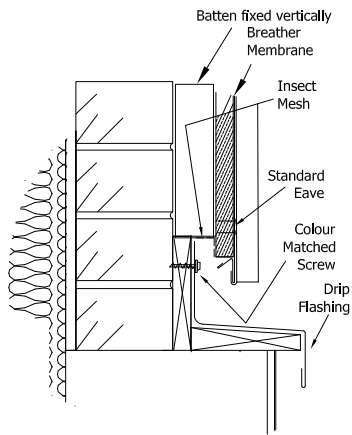

Detail round doors and window

1. Top Drip

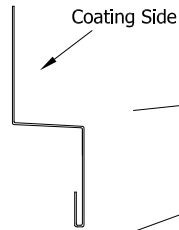

1.1 Bottom Drip

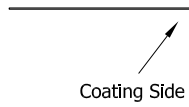

2. Side Window Reveal

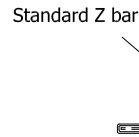

Coating Side

Coating Side

3. Bottom Drip

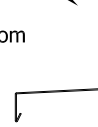

Coating Side

Standard Z bar

4. For Window Sill

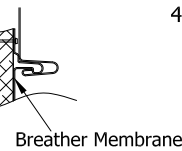

Breather Membrane

Colorcoat Urban

Bent Bar/Shallow Z bar

External Corner

Detail round base doors

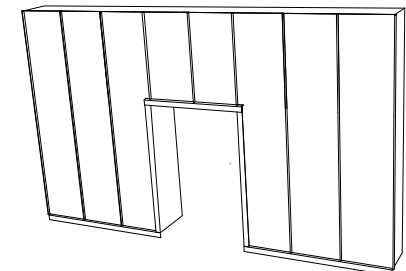

This drawing is the exclusive property of Tata Steel must not be copied or otherwise reproduced in anyway whatsoever without the express consent in writing of the corporation. The contents of the drawing must be treated as strictly confidential and must not be disclosed to any third party without the express consent in writing of the corporation.

Title

Wall Details

Drawing No.

ASU030

Scale : N/A

Copyright - Tata Steel © 2012

Rev: O

Colorcoat Urban
Shotton Works
Deeside
CH5 2NH

Tel: +44 (0)1244 89 2449
Fax: +44 (0)1244 89 2442
www.colorcoaturban.com

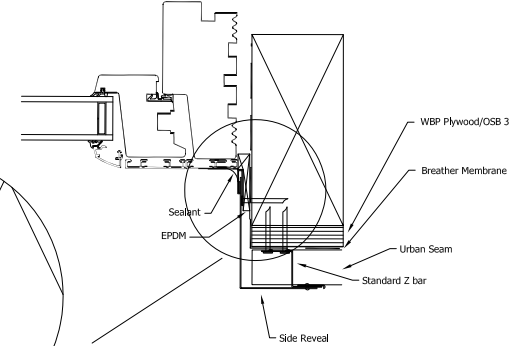
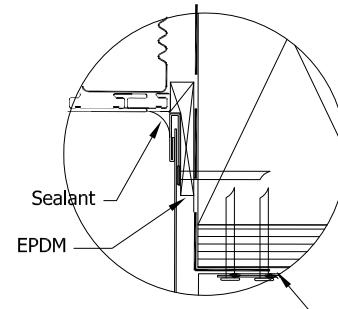
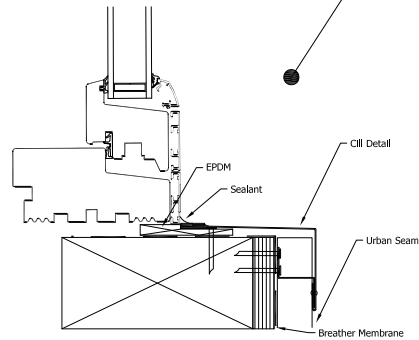
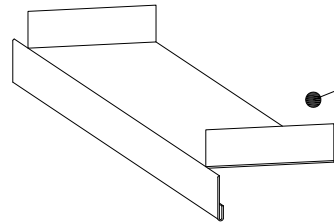
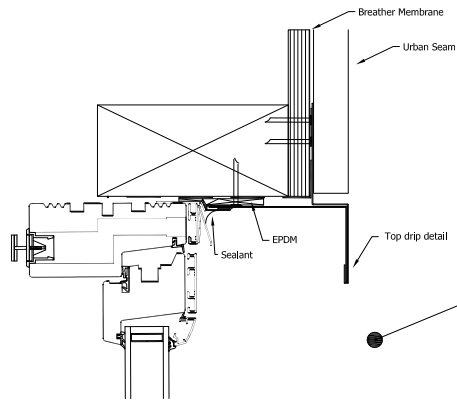

This drawing is the exclusive property of Tata Steel must not be copied or otherwise reproduced in anyway whatsoever without the express consent in writing of the corporation. The contents of the drawing must be treated as strictly confidential and must not be disclosed to any third party without the express consent in writing of the corporation.

Title	Window Detail
Drawing No.	ASU031

Scale : N/A
Rev: O

Copyright - Tata Steel © 2012	
Colorcoat Urban Shotton Works Deeside CH5 2NH	Tel: +44 (0)1244 89 2449 Fax: +44 (0)1244 89 2442 www.colorcoaturban.com

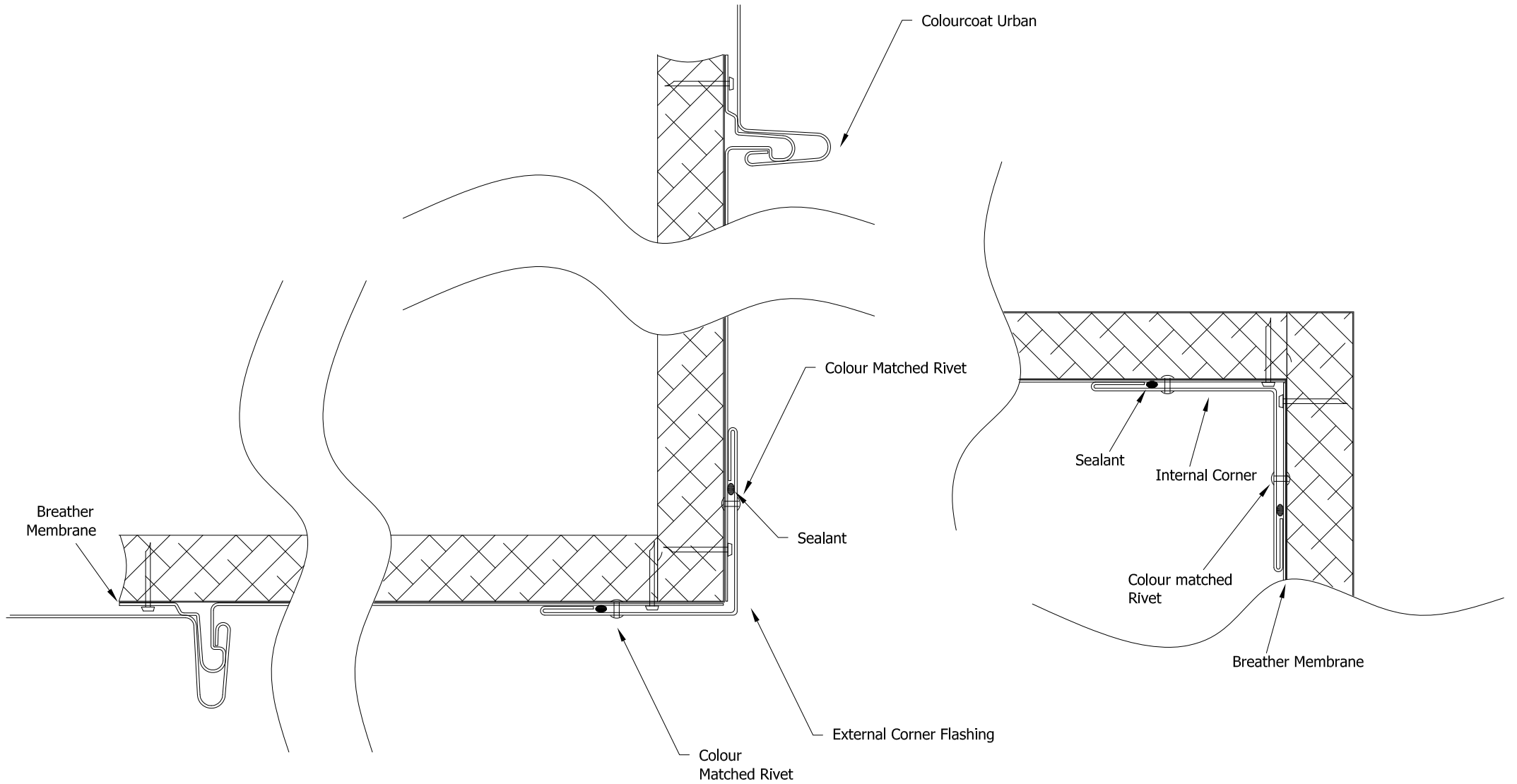

This drawing is the exclusive property of Tata Steel must not be copied or otherwise reproduced in anyway whatsoever without the express consent in writing of the corporation. The contents of the drawing must be treated as strictly confidential and must not be disclosed to any third party without the express consent in writing of the corporation.

Title

External and Internal Corner

Drawing No.

ASU032

Scale : N/A

Copyright - Tata Steel © 2012

Rev: O

Colorcoat Urban
Shotton Works
Deeside
CH5 2NH

Tel: +44 (0)1244 89 2449
Fax: +44 (0)1244 89 2442
www.colorcoaturban.com

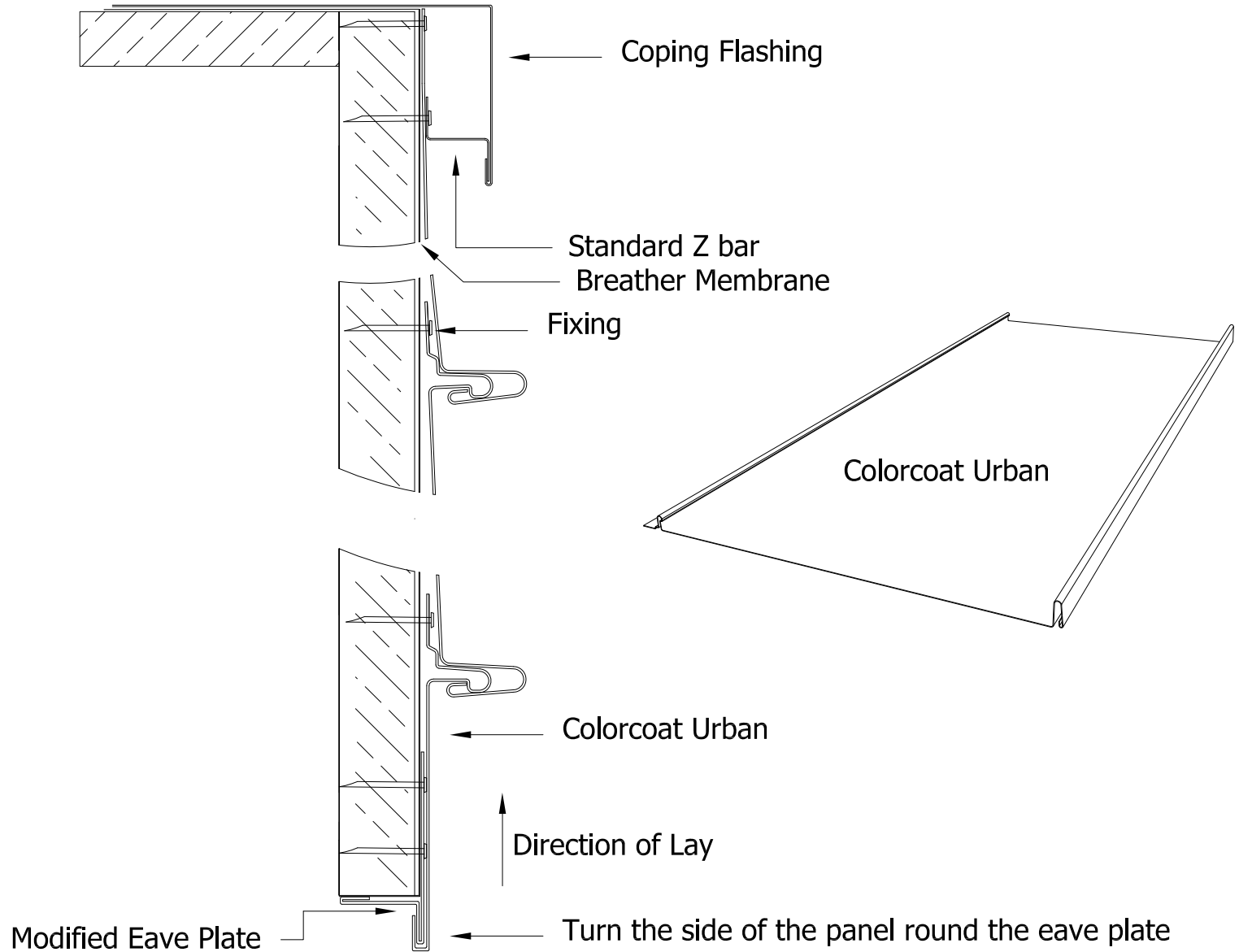

This drawing is the exclusive property of Tata Steel must not be copied or otherwise reproduced in anyway whatsoever without the express consent in writing of the corporation. The contents of the drawing must be treated as strictly confidential and must not be disclosed to any third party without the express consent in writing of the corporation.

Title

Laying panels horizontally

Drawing No.

ASU033

Scale : N/A

Copyright - Tata Steel © 2012

Rev: O

Colorcoat Urban
Shotton Works
Deeside
CH5 2NH

Tel: +44 (0)1244 89 2449
Fax: +44 (0)1244 89 2442
www.colorcoaturban.com

www.colorcoaturban.com

Trademarks of Tata Steel

Colorcoat, Colorcoat Connection and Colorcoat Urban are trademarks of Tata Steel.

Corus is part of the Tata Steel group.

Care has been taken to ensure that the contents of this publication are accurate, but Tata Steel UK Limited and its subsidiaries do not accept responsibility or liability for errors or information that is found to be misleading. Suggestions for, or descriptions of, the end use or application of products or methods of working are for information only and Tata Steel UK Limited and its subsidiaries accept no liability in respect thereof.

Before using products supplied or manufactured by Tata Steel UK Limited and its subsidiaries, customers should satisfy themselves as to their suitability.

Printed on material which is manufactured from ECF (Elemental Chlorine free) pulp sourced from certified or well managed forests and plantations. Inks used are vegetable based.
Copyright 2008 Tata Steel

Sales Contact Details

Colorcoat Urban
Tata Steel Colors
Shotton Works
Deeside
Flintshire CH5 2NH
United Kingdom
T: +44 (0)1244 892449
F: +44 (0)1244 892442

www.colorcoaturban.com
Colorcoaturban@tatasteel.com

W: **www.colorcoaturban.com**
Language English 0708