



Chartwell Tree Consultants Ltd

2 Greencroft Cottage, Farley Lane,
Westerham, Kent, TN16 1UB
sam@chartwelltreeconsultants.co.uk
01959 569 280/07789 907 861

Arboricultural Method Statement

Site:

2, 4 & 6 Woodside Road
Sevenoaks
Kent
TN13 3HB

Planning Application Reference: 20/02448/FUL
Produced in Fulfilment of Condition 16

Prepared for: Mr & Mrs Wertheim & Mr & Mrs Benham

Prepared by:

Sam Bateson. Tech.Cert. (M.Arbor. A.)

8th April 2021

Contents

Section		Page
1)	Terms of Reference	3
2)	Site Information	4
3)	Introduction	5
4)	Tree Works	6
5)	Tree Protection	9
6)	Development Operations	14
Appendix 1:	Sample Tree Protection Notices	22
Appendix 2:	Site Supervision / Site Visit Record	24
Appendix 3:	Reference Material	25
Appendix 5:	Key Messages for Site Induction	26
Drawings:	Tree Removal and Retention Plan Tree Protection Plan	

1) Terms of Reference

- 1.1 I received my initial instructions from John Wertheim via email on the 28th February 2021.
- 1.2 I have been instructed to produce an Arboricultural Method Statement (AMS) in line with British Standard **BS5837: 2012 'Trees in Relation to Design, Demolition and Construction Recommendations'** with regards the proposed construction at the above address.
- 1.3 The information contained within this Arboricultural Method Statement does not constitute a tree safety inspection.
- 1.4 Qualifications held by me include:
- Arboricultural Association Technicians Certificate
 - LANTRA Professional Tree Inspection

I have 19 years of practical arboricultural experience at craft level, as a local authority arboricultural officer, arboricultural contracts manager and as an independent consultant.

Signed:



Sam Bateson



8th April 2021

2) Site Information

2.1 Site Address

2, 4 & 6 Woodside Road
Sevenoaks
Kent
TN13 3HB

2.2 Planning Information (Planning application: 20/02448/FUL)

Land North Of 2-6 Woodside Road Sevenoaks KENT TN13 3HB Development: Erection of three detached dwellings to incorporate a new vehicular access.

Planning Condition 16 relates to the Arboricultural Method Statement and protection of trees on and adjacent to the site.

	Name	Contact Details
Client	Mr & Mrs Wertheim & Mr & Mrs Benham	2 & 4 Woodside Road Sevenoaks Kent TN13 3HB
Architect/Designer	Nigel Green & Mr Stuart Coleman	Lusted Green 2 Sunspan Wentworth Close Long Ditton KT6 5DY 0203 176 2770 nigel@lustedgreen.com Coleman Anderson Architects Ltd 4 Wertern Road Southborough TN4 0HX Tel: 01892 537124 stuart@colemananderson.co.uk
Site Manager/ Contractor	Mr D Antiss	Olive Tree Building Ltd Tel: 07901 552618 office@olivetreebuild.com
Arboriculturist	Sam Bateson	2 Greencroft Cottage Farley Lane Westerham Kent TN16 1UB Tel: 07789 907 861 sam@chartwelltreeconsultants.co.uk
Local Planning Authority (LPA)	Sevenoaks Council	Council Offices Argyle Road Sevenoaks Kent TN13 1HG 01732 227000
Planning Case Officer	Mr Alexis Stanyer	Tel: 01732 227000
Principal Tree Officer	Mr Les Jones	Tel: 01732 227000

3) Introduction

To be read in conjunction with the Tree Protection Plan. Copies of these plans are to be available on-site at all times for staff and contractors to see.

3.1 Overview

This document outlines the methodology to be followed for any operation that may result in the loss or damage of trees on the development site. In particular:

- Trees to be retained and removed
- How trees will be protected
- How works close to trees will be carried out
 - Phasing
 - Intensity
 - Method Statements for Specific Operations
- Responsibilities, supervision and emergency procedures

Copies of this document will be available on site for consultation. Reference will be made throughout to **BS5837: 2012 'Trees in relation to design, demolition and construction – Recommendations'**.

3.2 Legal Considerations

The site is not within a Conservation Area and there are no Tree Preservation Orders.

3.3 Significance of Planning Conditions (with reference to Sevenoaks Council's policy)

The grant planning permission for this development is subject to the approval of and compliance with this Arboricultural Method Statement.

Planning Condition 16 (20/02448/FUL):

The requirements of Condition 16:

No development shall commence on site until full details of tree protection measures have been submitted to the Local Planning Authority for approval in writing. The development shall be implemented in accordance with the approved details.

In the interests of maintaining the visual amenity of the area in accordance with Policy EN1 of the Sevenoaks Allocations and Development Management Plan.

Any breaches of this or other conditions may result in the Local Planning Authority carrying out an investigation of that breach. The property owner / developer will be advised to adhere to the requirements of the planning conditions. If the breach continues to take place the council can use

various planning enforcement tools such as a Temporary Stop Notice, Enforcement / Stop Notice, and a Breach of Condition Notice.

3.4 **Notifying the Local Planning Authority**

Appropriate notice as required by the LPA should be given prior to the commencement of site works. It is the responsibility of the Client or their appointed Site Agent / Manager to ensure that such notice has been given. This includes obtaining the permission in writing of the Local Authority Tree Officer before any activities are undertaken within a Construction Exclusion Zone (CEZ) or when any changes to the tree protection measures are made.

3.5 **Pre-Commencement Site Meeting**

A pre-commencement site meeting should be arranged between the Site Manager and arboriculturist (with the LA Tree Officer invited to attend) to discuss issues of tree protection, emergency procedures and appropriate precautions to avoid damage to rooting systems.

4) Pre- Construction Schedule of Tree Works

4.1 **Trees to be Retained**

The following trees within and adjacent to the site boundary are to be **retained** with appropriate protection:

Tree No.	Species	Pre-Development Tree Work to implement Planning Permission
T1	Chamaecyparis lawsoniana (Lawson Cypress)	No works required.
T2	Cupressus macrocarpa (Monterey Cypress)	No works required.
T3	Prunus domestica (Damson)	No works required.
T4	Prunus Kanzan (Cherry)	No works required.
T5	Acer pseudoplatanus (Sycamore)	No works required.
T6	Acer pseudoplatanus (Sycamore)	No works required.
T7	Acer pseudoplatanus (Sycamore)	No works required.
T8	Acer pseudoplatanus (Sycamore)	No works required.
T9	Acer pseudoplatanus (Sycamore)	No works required.
T10	Acer pseudoplatanus (Sycamore)	No works required.
T11	Castanea sativa (Sweet Chestnut)	No works required.
T14	Acer pseudoplatanus (Sycamore)	No works required.

H1	Corylus avellana (Hazel),Fagus sylvatica (Beech),Ilex aquifolium (Holly)	No work required.
T18	Ilex aquifolium (Holly)	No work required.
T24	Quercus robur (Common Oak)	No work required.
T28	Acer pseudoplatanus (Sycamore)	No work required.
T29	Quercus robur (Common Oak)	To reduce in height by 3m and lateral spread by 1m (20%).
T31	Fagus sylvatica (Beech)	To reduce in height by 2m and lateral spread by 1m (20%).
H2	Fagus sylvatica (Beech),Corylus avellana (Hazel),Ilex aquifolium (Holly)	To remove a part section to allow for access driveway - see TPP for location.
T33	Corylus avellana (Hazel)	To reduce in height by 1.5m and lateral spread by 1.5m.
T37	Cedrus deodora (Deodar)	To cut back branches as required to allow for build - access facilitation pruning only (AFP).
T38	Tilia X europaea (Common Lime)	To cut back branches as required to allow for build - access facilitation pruning only (AFP).
T39	Fagus sylvatica (Beech)	No works required.
T41	Quercus robur (Common Oak)	To cut back branches as required to allow for build - access facilitation pruning only (AFP).
T42	Quercus robur (Common Oak)	To cut back branches as required to allow for build - access facilitation pruning only (AFP).
T43	Quercus robur (Common Oak)	To cut back branches as required to allow for build - access facilitation pruning only (AFP).
T46	Acer pseudoplatanus (Sycamore)	No work required.
T47	Corylus avellana (Hazel)	To reduce in height and lateral spread by 50%.
T49	Fagus sylvatica (Beech)	To reduce in height by 3m and lateral spread by 1m (20%).
T51	Acer pseudoplatanus (Sycamore)	To cut back branches as required to allow for build - access facilitation pruning only (AFP).
T52	Acer pseudoplatanus (Sycamore)	Owner should arrange inspection.
T53	Laurus nobilis (Bay)	No works required.
H3	Fagus sylvatica (Beech)	To remove a part section and heavily prune the canopy to the north to allow for access driveway - see TPP for location.
T51	Acer pseudoplatanus (Sycamore)	To cut back branches as required to allow for build - access facilitation pruning only (AFP).

4.2 Trees to be Removed

The following trees are to be **removed** as detailed on the Tree Removal Plan. Trees to be removed are marked by a **red dashed circle**.

Tree No.	Species	Pre-Development Tree Work to implement Planning Permission
T13	Chamaecyparis lawsoniana (Lawson Cypress)	Remove tree and poison stump.
T15	Chamaecyparis lawsoniana (Lawson Cypress)	Remove tree and grind stump.
T16	Picea abies (Norway Spruce)	Remove tree and grind stump.
G1	Chamaecyparis lawsoniana (Lawson Cypress x 6)	Remove trees and grind stumps.
T17	Thuja plicata (Western Red Cedar)	Remove tree and grind stump.
T19	Acer pseudoplatanus (Sycamore)	Remove tree and grind stump.
T20	Fagus sylvatica (Beech)	Remove tree and grind stump.
T21	Fagus sylvatica (Beech)	Remove tree and grind stump.
G2	Chamaecyparis lawsoniana (Lawson Cypress x 6)	Remove trees and grind stumps.
T22	Fagus sylvatica (Beech)	Remove tree and grind stump.
G3	Chamaecyparis lawsoniana (Lawson Cypress, Prunus laurocerasus (Cherry Laurel)	Remove trees and grind stumps.
T23	Chamaecyparis lawsoniana (Lawson Cypress)	Remove tree and grind stump.
G4	Prunus laurocerasus (Cherry Laurel), Corylus avellana (Hazel), Chamaecyparis lawsoniana (Lawson Cypress), Prunus Kanzan (Cherry)	Remove trees and grind stumps.
T25	Malus sylvestris (Crab Apple)	Remove tree and grind stump.
T26	Fagus sylvatica (Beech)	Remove tree and grind stump.
T27	Prunus avium (Wild Cherry)	Remove tree and grind stump.
T30	Picea abies (Norway Spruce)	Remove tree and grind stump.
T32	Chamaecyparis lawsoniana (Lawson Cypress)	Remove tree and grind stump.
H2	Fagus sylvatica (Beech), Corylus avellana (Hazel), Ilex aquifolium (Holly)	To remove a part section to allow for access driveway - see TPP for location.
T34	Corylus avellana (Hazel)	Remove tree and grind stump.
T35	Chamaecyparis lawsoniana (Lawson Cypress)	Remove tree and grind stump.
T36	Picea abies (Norway Spruce)	Remove tree and grind stump.
T40	Malus sylvestris (Crab Apple)	Remove tree and grind stump.
T45	Chamaecyparis lawsoniana (Lawson Cypress)	Remove tree and grind stump.
T48	Populus nigra 'Italica' (Lombardy Poplar)	Remove tree and grind stump.

G5	Chamaecyparis lawsoniana (Lawson Cypress)	Remove trees and grind stumps.
T50	Chamaecyparis lawsoniana (Lawson Cypress)	Remove tree and grind stump.
H3	Fagus sylvatica (Beech)	To remove a part section and heavily prune the canopy to the north to allow for access driveway - see TPP for location.
G6	Ilex aquifolium (Holly)	Remove trees and grind stumps.
T54	Fagus sylvatica (Beech)	Remove tree and grind stump.
T55	Quercus robur (Common Oak)	Remove tree and grind stump.

(AFP) – This is considered to be ‘Access Facilitation Pruning’ as per BS: 5837, 8.8.1.2 c and should be the absolute minimum necessary to ensure the safe passage of any high-sided, over size vehicles or the installation of new access areas. A banksman will supervise any movement of machinery or high-sided vehicles along the existing driveway.

The above works are required to implement the planning permission, there is a presumption that written approval of this Arboricultural Method Statement will represent deemed consent for the above works without further reference to the Local Planning Authority.

4.3 **Conditions Regarding Tree Work**

Tree work is a potentially hazardous activity; anyone carrying out these operations must be appropriately trained, experienced and carry appropriate insurance. All works will be carried out in accordance with BS3998: 2010 ‘Recommendations for Tree Work’. In addition:

- Dismantling techniques and vehicle access within the Root Protection Areas (RPA’s) of any retained trees must minimize the risk of damage e.g. soil compaction, using temporary ground protection where necessary
- Full consideration must be given to all relevant legislation including the Health and Safety at Work Act 1974, the Management of Health and Safety at Work Regulations 1999, the Wildlife and Countryside Act 1981 (as amended), The Countryside and Rights of Way Act 2000 and the Conservation of Habitats and Species Regulations 2010 regarding European Protected Species such as bats
- All tree works to be carried out **only** by qualified and competent arboricultural contractors
- Contractors to confirm TPO / Conservation Area status and necessary permissions before work starts.

5) Tree protection

5.1 **Protective Fencing**

Protective fencing (highlighted in **ORANGE** on the Tree Protection Plan) will be fit for purpose, complying with Figures 2-3 in BS5837:2012 (see below) unless otherwise specified and agreed in writing by the LPA. For example, the alternative use of a wooden post framework with plywood

hoarding (Photo 1) or bespoke traffic barrier systems (Photo 2) as alternative forms of protection for Oak tree T24 – **providing they can be securely installed** without causing any root damage. Site huts or temporary buildings may also be used as part of the protective barriers (BS5837 section 6.2.2.3).

BRITISH STANDARD

BS 5837:2012

Figure 2 Default specification for protective barrier

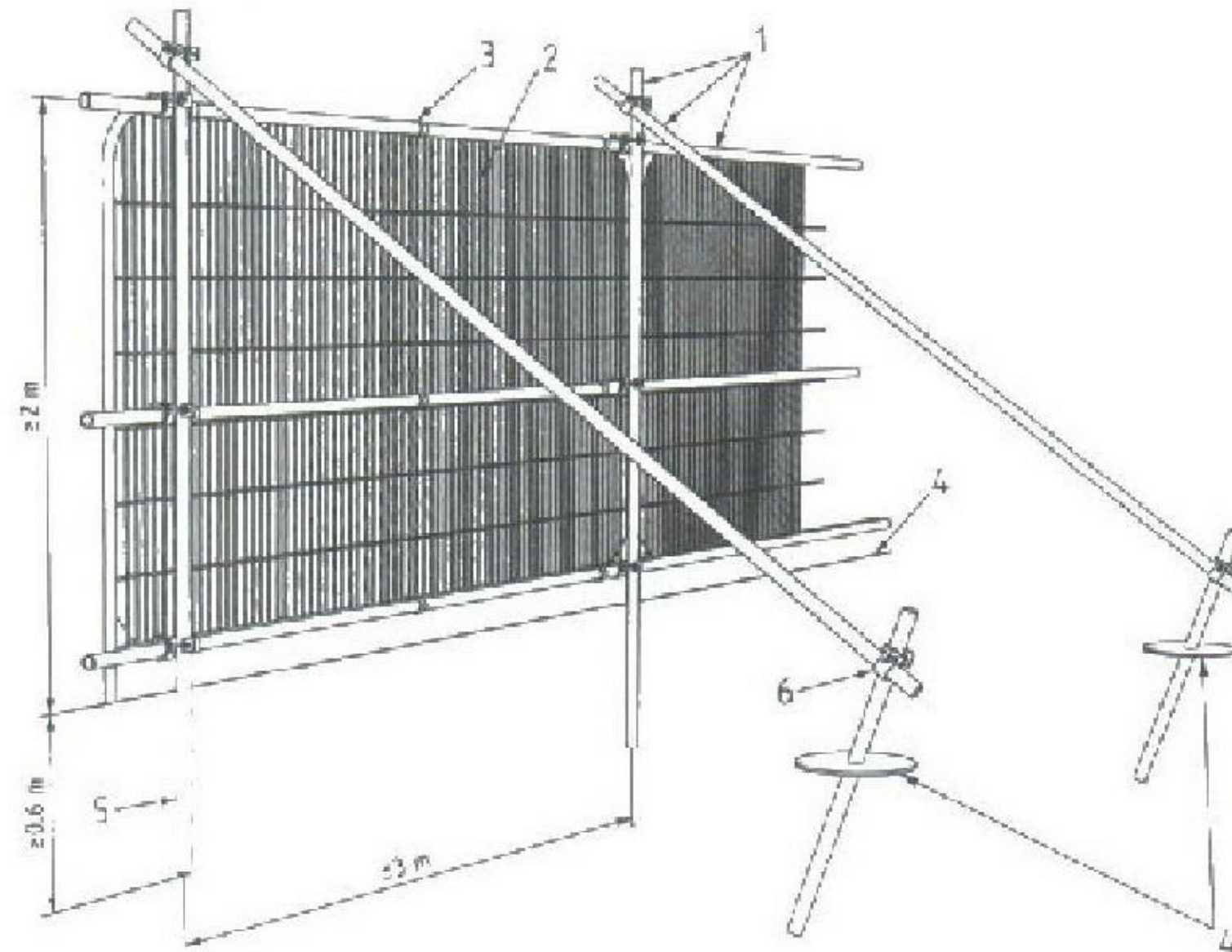

Key

- 1 Standard scaffold poles
- 2 Heavy gauge 2 m tall galvanized tube and welded mesh infill panels
- 3 Panels secured to uprights and cross-members with wire ties
- 4 Ground level
- 5 Uprights driven into the ground until secure (minimum depth 0.6 m)
- 6 Standard scaffold clamps

Figure 3 Examples of above-ground stabilizing systems

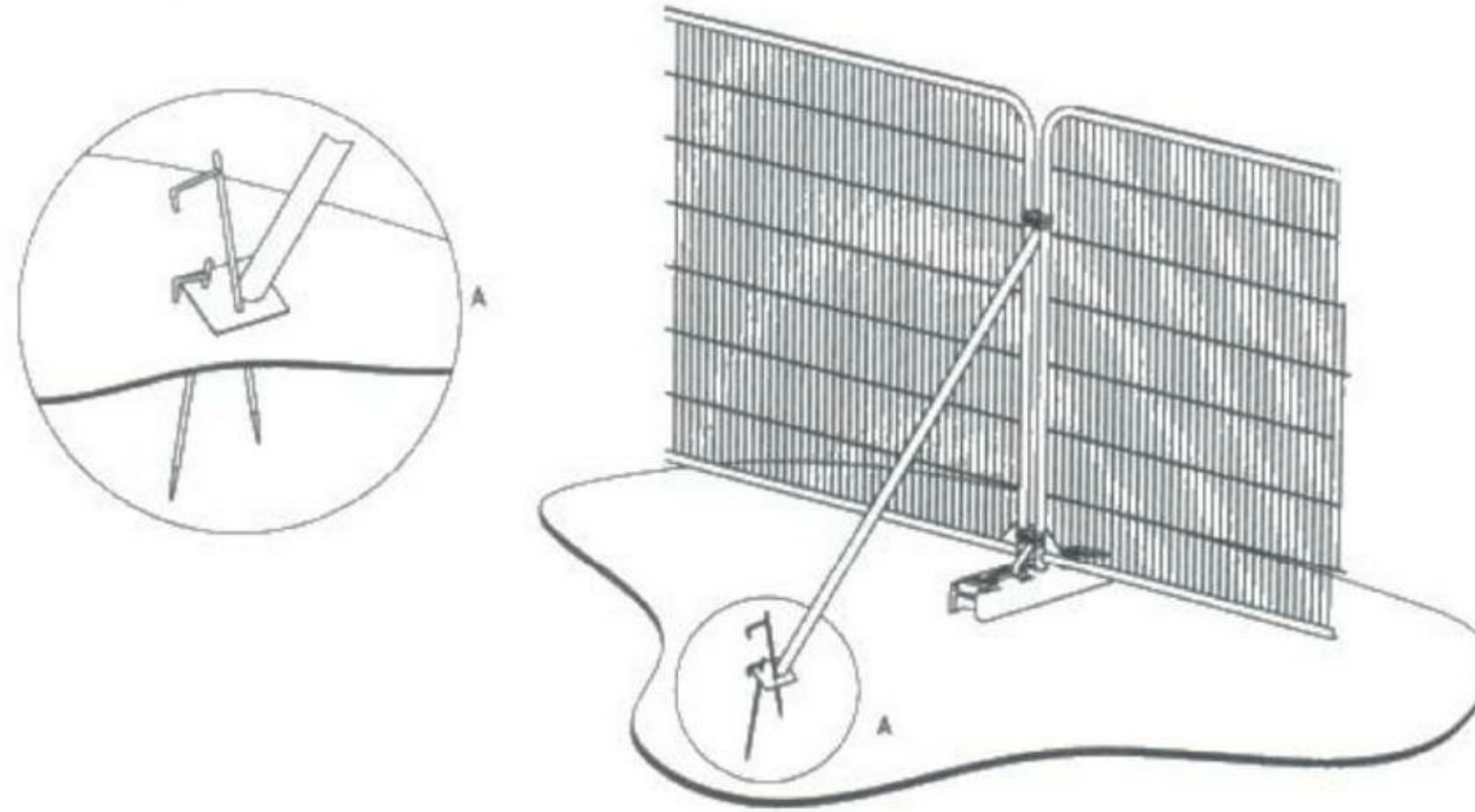

a) Stabilizer strut with base plate secured with ground pins

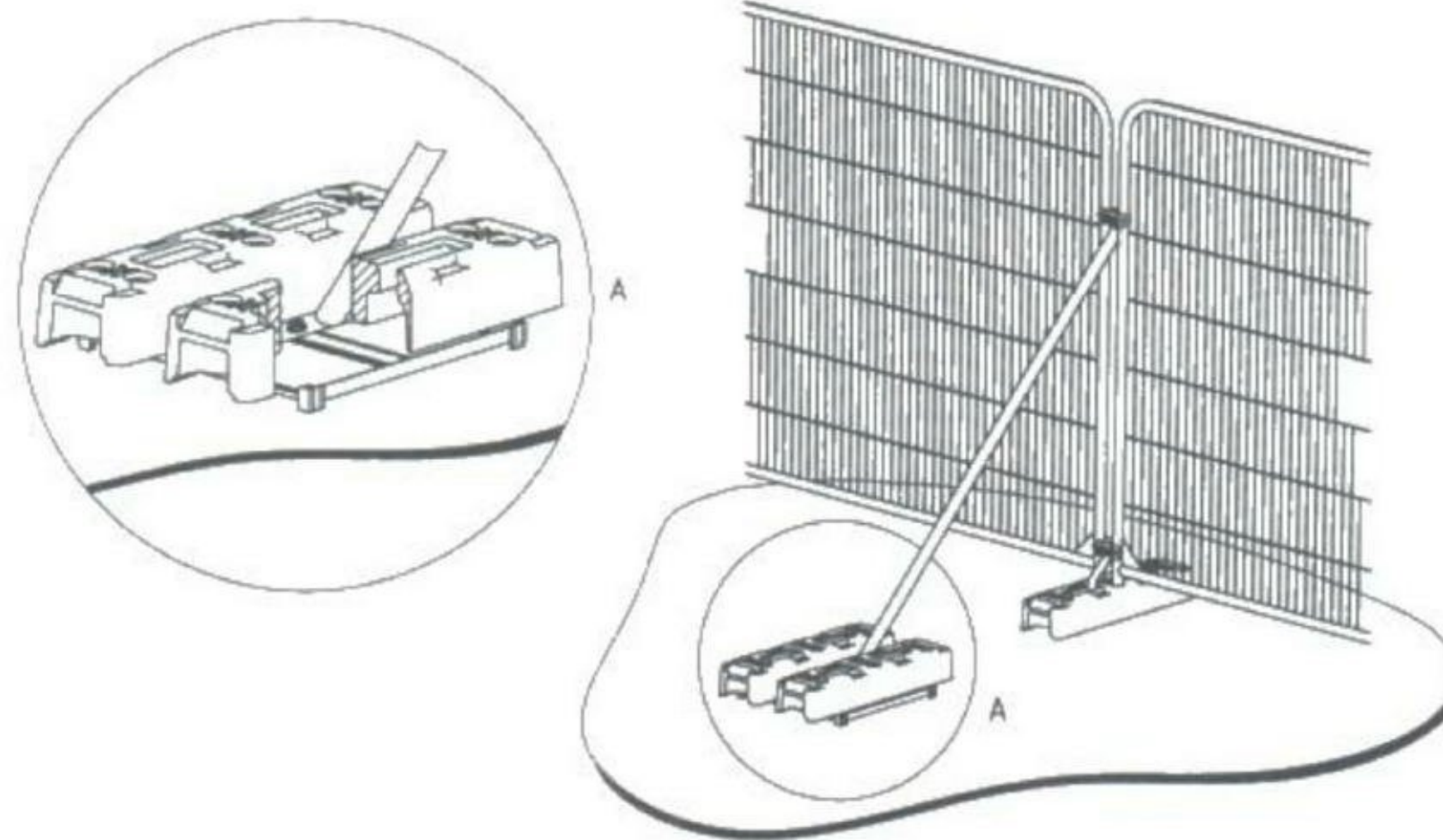

b) Stabilizer strut mounted on block tray



Photo 1: Alternative Hoarding Protection



Photo 2: Example of Bespoke Traffic Barrier System

Protective fencing will:

- Be erected prior to any demolition or construction (excluding pre-development tree works) taking place at distances specified within the approved plans.
- Have appropriate all-weather warning signs clearly affixed e.g. **'PROTECTED TREE – KEEP OUT'** (See Appendix 2 for suggested examples)

- Remain in place until completion of the construction phase. Removal only to take place following the approval of Chartwell Tree Consultants.
- Comply with the requirements of the Construction (Design & Management) Regulations 2015 with regards temporary hoarding.

Once erected, the area within the barriers – the **Construction Exclusion Zone** (marked 'CEZ' on the Tree Protection Plan) – must be regarded as sacrosanct and not removed or altered without the prior recommendation of an arboriculturist and approval of the LPA / Local Authority Tree Officer.

Where space does not allow for the installation of a scaffold framework to support the protective fencing, panels are to be affixed to secure anchor blocks to prevent unauthorised movement or removal. NB: Where the client or their appointed Site Agent / Manager sees that any alternative anchor systems are being moved without authorisation then the fencing must be upgraded to the full BS 'Figure 2' specification.

Where site huts or temporary storage containers are used as components of the protective fencing or temporary ground protection the following precautions should be observed:

- Retain the existing hard surfacing or use railway sleepers (or similar bulk timber / ground mats) to spread the load
- No excavation within the RPA to install the huts and no trenching to install temporary services e.g. drainage to the site facilities
- Observe all precautions set out in this document regarding discharge of materials, diesel, concrete, etc. and emergency procedures in the event of spillages

Extreme care must be taken to avoid underground utilities or buried obstacles when installing any support poles or pipes i.e. by referring to utilities plans and using a Cable Avoidance Tool. When siting and installing support pole locations, the top 600mm of ground must be carefully excavated by hand or air pick to ensure that no significant roots will be damaged during the installation.

5.2 **Ground Protection & Temporary Access**

Where temporary ground protection is required within the Root Protection Area or CEZ of a retained tree(s) then this should be designed to cope with the expected load and be capable of preventing soil compaction. Detailed guidance is provided in BS5837:2012 section 6.2.3.3 including for:

1. Pedestrian movement (including scaffolding) - a single-thickness scaffold board on top of a compressible layer e.g. 100mm depth of woodchip laid on a geotextile fabric

2. Pedestrian-operated plant up to 2t – proprietary ground protection boards on top of a compressible layer e.g. 150mm depth of woodchip laid on a geotextile fabric
3. Construction machinery exceeding 2t – proprietary ground protection or pre-cast slabs to an engineer's specification. An assessment of the need for upgrading the existing driveway should be made by an engineer before commencement of works

Ground protection will be required for specific areas (highlighted in **RED** on the Tree Protection Plan). I would recommend the installation of a geotextile membrane, 150mm cellweb overcharged with no fines gravel, however the specification is ultimately the responsibility of the principal site contractor. See below examples:



Ground protection is to be removed by hand at the end of the build process or used as part of the sub-base for the new surfacing.

Where scaffolding requires additional space to be safely installed or for a wider working width, the tree protection fencing may be moved back as required only if this is accompanied by a corresponding increase in appropriate ground protection. If the supporting feet need to be placed directly onto the ground for reasons of stability, their combined area should not result in a significant incursion into any RPA.

6) Development Operations

6.1 The nature of the development and available space should result in a Moderate intensity build environment as overseen by the site agent. Specific details include:

Site Access	Use of existing hard standing road surfaces into Woodside Road. Plant movements, deliveries and high sided vehicles to be overseen by banksman.
Build Sequence	<ul style="list-style-type: none"> • Tree works / scrub clearance • Erection of protective fencing and site hoarding • Installation of the ground protection and new access drive sub-base (overcharged 150mm cellweb) • Ground works • Construction of dwellings and drainage installation • Hard landscaping • Soft landscaping • Removal of protective fencing and ground protection
Service Installation	New above and below ground drainage to be carried out in accordance with BS EN 12056 part 2 and BS EN 752 part 1 respectively and to water supplier's specifications.
Contractors Car Parking	Off street parking or on street parking in accordance with local restrictions
Deliveries / Storage	Outside of any marked CEZ's. No materials to be stored / no concrete mixed / re-fuelling in any CEZ. Dedicated cement mixing / hot works area. Flammable materials / cylinder storage to be located in safe location outside of any CEZ
Site Huts / Welfare Facilities	As Contractors Parking

6.2 Demolition

Adequate space exists for the demolition of the existing structures provided that adequate temporary ground protection and fencing is in place and that any plant movements are supervised. The limited amount of dust anticipated should avoid the need for water / hosepipes to wash down neighbouring trees.

6.3 Foundations

The precise foundation design is yet to be determined although it is presumed (subject to confirmation by the architect / structural engineer) that for most areas traditional strip foundations will be used subject to any appropriate anti-heave precautions (if assessed as necessary based upon detailed geotechnical assessment and reference to NHBC Chapter 4.2, 2017). The surrounding soil adjacent (the CEZ) should be protected from the effects of wet concrete through the use of an impermeable liner.

Areas (shown in **BLUE** on the Tree Protection Plan) will require either an above ground raft, cantilever and or pile and above ground beam (Low-invasive) solution to prevent root severance (subject to confirmation by the architect / structural engineer).

A copy of the finalised foundation designs should be attached to the AMS when available and the project arboriculturist consulted on the need for any additional precautions to protect retained trees. The excavation of trial pits at an early stage of the development to determine the extent of root spread may assist with this decision.

6.3 Works within the RPA

The existing surfaces are to be removed by hand, existing hard surface, weeds, grass etc and the levelling of the area also to be undertake using hand tools. TRENCHING OR HEAVY MACHINERY IS FORBIDDEN. Any roots smaller than 25mm may be pruned back using handsaws or secateurs. Roots larger than 25mm can only be severed following consultation with Chartwell Tree Consultants.

Drainage within any root protection areas will require trenchless methods (moling, air spading and or pipe ramming) and will need to be implemented as detailed in BS5837 Table 3.



Root severance, tree de-stabilised



Significant roots retained

New soakaways have been sited outside the Root Protection Areas.

Existing or proposed retaining walls are to be repaired or constructed under arboricultural supervision so as to minimise rooting area disruption.

Replacement of existing retaining wall to the East of 2a is to be constructed using Steel H Beam and sleeper wall design.

New walls within the RPA's to be either Steel H Beam and sleeper wall, pile and above ground beam (see below example) or above ground gabion design.

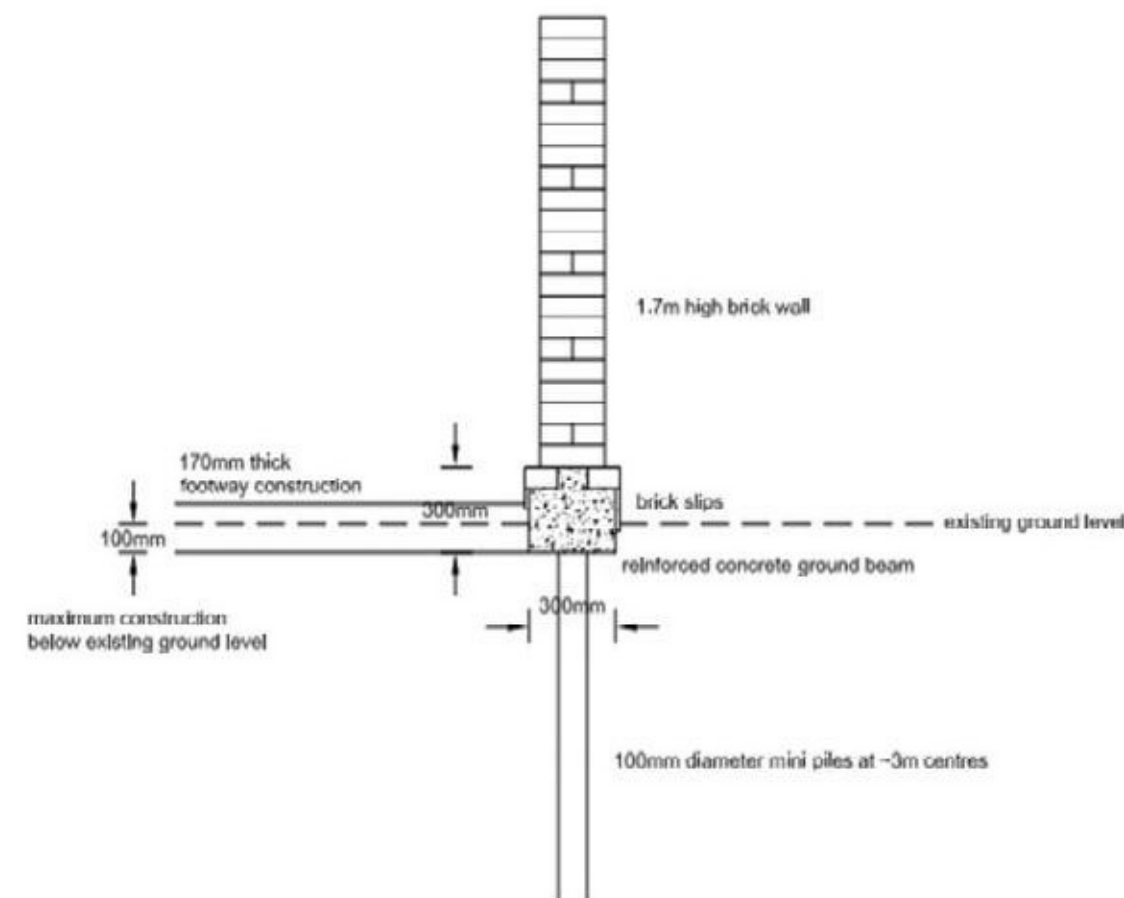

Excavations for any new gates and fencing to be dug by hand to check for tree roots >25mm. Post holes to be lined with heavy gauge polythene to prevent concrete leaching.

No mixing or runoff is allowed within the CEZ.

6.4 **Hard Surfaces**

The existing surfacing (grass, tarmac etc) is to be carefully lifted using hand tools or supervised plant working from the existing hard surface to the front and immediately replaced with the new surface. Care should be taken to avoid damage to roots that may be present beneath the surface. Any material removed should be stored outside of any CEZ. Areas of the hard standing within the root protection areas (shown in GREEN on the Tree Protection Plan) are to be installed with low invasive techniques using hand tools and the utilization of a cellular confinement system as part of the sub-base. This surface must be fit-for-purpose with specialist advice obtained from an engineer to meet the above performance specification. Proprietary products such as 'Cellweb, CORE, Terram' are available that can help deliver the performance specification e.g. www.geosyn.co.uk or telephone 0870 850 1018 (Geosynthetics Ltd).

Example Below

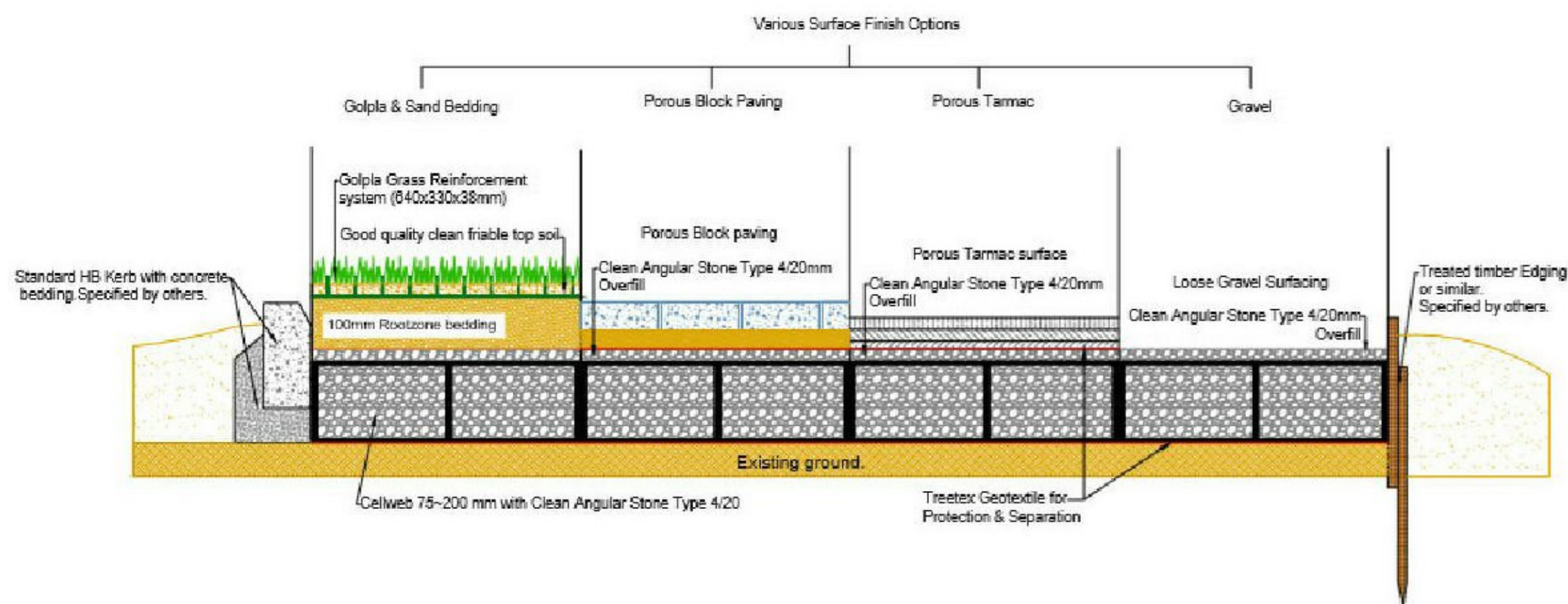

Diagram 2: Example of low-invasive surfacing with alternative surface treatments and no-dig edging

Removal of existing surfaces within the RPA's should be carried out carefully using hand tools or other appropriate machinery (under supervision from a qualified arboriculturist). In order to minimise the impact on the rooting area and tree root function within the RPA's the design of any new surface should adequately consider and allow for the following factors:

- Allows gaseous exchange (horizontally and vertically)
- Water permeable while preventing contaminants from entering the soil.
- Preserves the soil structure at a suitable bulk density
- Prevents contaminants entering the rooting area
- Prevents damage to the roots during demolition or construction
- Recognises the fact that the majority of roots are found in the top 600mm of soil

Practical measures that can achieve this include:

- No significant changes in ground level
- No soil capping
- No excavation / minimal excavation e.g. removal of turf layer or organic material
- Avoiding soil compaction methods e.g. when constructing a sub base

Suggested Method: (further information available in section 7.4 of BS5837:2012, APN 12).

- Existing hard surfacing or loose organic matter and / or turf to be carefully removed using hand-held tools or appropriate machinery working backwards over the area so that the machinery is not working on the exposed ground.
- Any roots encountered should be treated in accordance with section 7.2 of BS5837:2012. In particular roots greater than 25mm in diameter should only be severed following consultation with an arboriculturist and the LPA. Exposed roots should be immediately wrapped or covered to avoid desiccation. (NO TRENCHING, HEAVY EXCAVATION OR TRACKING OVER THE UNMADE GROUND PERMITTED).

- Fill any hollows using sharp sand (Builder's sand not to be used due to high salt content)
- Install the geotextile fabric layer
- Lay the cellular confinement system over the geotextile fabric layer.
- Fill the cellular confinement system using a no-fines angular material, working from the area already filled to minimise the risk of soil compaction
- Install finished **permeable** surface (may be delayed until completion of construction works if the sub-base is appropriately overcharged with no-fines angular material) according to architect's / engineer's specification. Ensure that a suitable low-invasive edging treatment is used e.g. secured railway sleepers, peg and boards or other proprietary edging product to avoid damage to roots.

6.5 **Tree Watering**

- The surrounding trees are well established middle aged to mature specimens and are therefore unlikely to require additional watering during the construction process as long as the Construction Exclusion Zone is kept sacrosanct. Regular monitoring is also to be undertaken to assess health and wellbeing.

6.6 **Hard Landscaping**

- Any new post holes or hard landscape foundations within the RPA should be carefully excavated using hand tools and should be positioned to avoid any damage to roots. Any roots encountered <25mm in diameter should be cleanly severed and treated in accordance with BS5837:2012 section 7.2. Roots >25mm should only be severed following arboricultural advice.
- Any in-situ poured concrete (e.g. new retaining walls / steps/ fencing) in close proximity to any retained trees must be separated from the existing soil by heavy duty impermeable membrane to prevent the potentially damaging effects on the rooting area.
- Post holes should be lined with heavy duty impermeable membrane prior to the pouring of any concrete.
- Landscaping operations should be carried out in accordance with BS4428:1989.

6.7 **Soft Landscaping (including new tree and shrub planting)**

1) Site Preparation:

- All ground preparation and planting operations adjacent to existing retained trees, shrubs and hedges to be undertaken using hand tools only. No chemicals of any description are to be used.
- Any changes in soil level +/- 300mm to be made using imported soil meeting BS3882:2007 'Multipurpose' classification standards.
- Shrub planting areas are to be graded to be approximately 50mm below any adjacent surfaces prior to planting and mulching. Remaining landscape areas to be graded flush with existing/finished levels.
- Landscaping operations should be carried out in accordance with the following British Standards:
 - BS4428:1989 'Code of practice for general landscape operations (excluding hard surfaces)'.
 - BS8545:2014 'Trees: from nursery to independence in the landscape – Recommendations'.
 - BS5837:2012, 'Trees in relation to design, demolition and construction – Recommendations'.
 - BS3996 'Nursery Stock' (all parts) and BS7370-4 'Recommendations for maintenance of soft landscape (other than turf)'.

2) New Tree or Shrub Planting:

- All planting to be handled, stored, transported and planting in accordance with BS8545:2014 Trees: from nursery to independence in the landscape - Recommendations
- All planting to be watered thoroughly (field capacity) prior to planting.
- Topsoil to all shrub planting areas to be improved with 50mm depth composted green waste to BSI PAS 100.
- Planting holes / trenches to be cultivated to a minimum of 300mm depth incorporating composted soil improver (detailed above) and slow release fertilizer to manufacturer's recommended rates.
- At time of planting compost and slow release fertilizer to be incorporated into backfill material at manufacturer's recommended rates.
- Trees to be double staked with crossbar using 75mm diameter x 1.65m tree stakes. Stakes to extend no more than 900mm above ground level. Tree to be tied to stakes using 75mm rubber tie and spacer block.

3) Mulch, Weed Control and Watering

- All planting areas (shrub and hedge) to be mulched with medium grade bark mulch laid to depth of 75mm.
- Areas of new planting to be hand weeded
- Shrubs to be watered as appropriate to ensure that the soil remains moist during the growing season (March-November).

6.8 Aftercare

Adequate soil moisture levels should be maintained around all new tree planting. Regular watering should be undertaken to ensure that the soil remains moist particularly during periods of hot weather and / or low rainfall (e.g. the application of up to 30L every 2 weeks during the Spring and Summer) and mulch reapplied as required. Trees should be inspected upon completion of the development and any post development works specified to BS3998:2010. Additional watering of the established mature trees on site is not considered necessary although water should be available to flush through any contamination.

6.9 Prohibited Activities / General Precautions

- No materials which will contaminate the soil e.g. concrete mixings, diesel, vehicle washings will be discharged **within 10m** of any tree stem
- No storage of materials or mixing of concrete / mortar **within 5m** of any stem
- No fires will be lit where their flames can extend to **within 6m** of any part of the tree
- Notice boards, etc. must not be attached to any part of a tree
- Consideration must be given to any slopes that may affect the run-off towards trees

6.9.1 Responsibilities

- Unless otherwise agreed in writing, it will be the responsibility of the Client or their appointed Site Agent / Manager to ensure that the content of this Arboricultural Method Statement is adhered to
- The main contractor and any sub-contractors are to be briefed by the Site Agent / Manager on the relevant sections of this prior to commencing any works particularly with regards to the Prohibited Activities. Copies of general information regarding the prevention of damage to trees are included in Appendix 4 to assist with the site induction
- The Site Agent / Manager is responsible for contacting Chartwell Tree Consultants at any time relating to unforeseen issues to the trees on site.
- It is the responsibility of the Client/Site Agent to compile all conditions for submission to the LPA – this includes site supervision records at the completion of the build.

6.9.2 **Supervision & Emergency Procedures**

- Day-to-day supervision will be the responsibility of the Site Agent / Manager.
- Arboricultural site supervision is not required.
- Chartwell Tree Consultants Ltd to be contacted on 07789907861 for advice immediately following any unauthorised incursion into a Construction Exclusion Zone and the LPA to be informed.
- Water is readily available on site and will be used to flush spilt materials through the soil and minimise tree root contamination. At the time of any such incident, the site agent / manager is to contact an arboriculturist for advice
- Spill kits to be available at all times
- A copy of this Arboricultural Method Statement to be available on site at all times
- A pre-commencement site meeting may be required at the discretion of the LPA / LA Tree Officer to identify or clarify any outstanding issues.

WARNING

PROTECTED TREE

Tree Protective barriers are essential to protect tree roots from soil compaction, contamination, poisoning, etc.

Tree Protective Barriers MUST NOT BE REMOVED or REPOSITIONED unless permitted to do so by the Local Planning Authority (LPA).

**The barriers MUST remain in place until completion of the development
Or such earlier time as agreed by the LPA.**

**PROSECUTION may result from a failure to adhere to these instructions.
Sevenoaks Council can be contacted on 01732 227000.**

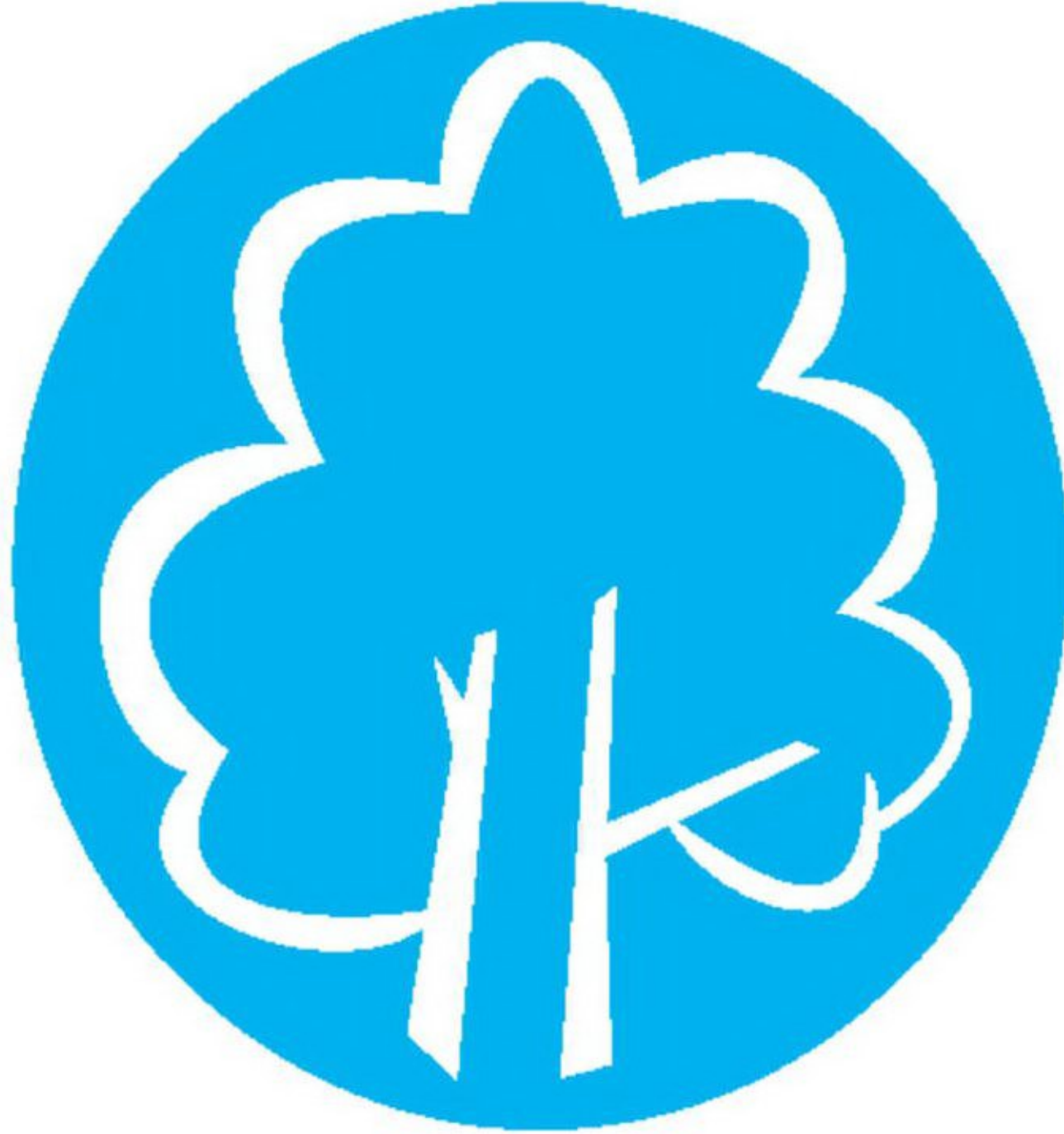

PROTECTIVE FENCING. THIS FENCING MUST BE MAINTAINED IN ACCORDANCE WITH THE APPROVED PLANS AND DRAWINGS FOR THIS DEVELOPMENT.



**TREE PROTECTION AREA
KEEP OUT !**

**(TOWN & COUNTRY PLANNING ACT 1990)
TREES ENCLOSED BY THIS FENCE ARE PROTECTED BY PLANNING CONDITIONS AND/OR ARE THE SUBJECTS OF A TREE PRESERVATION ORDER.
CONTRAVENTION OF A TREE PRESERVATION ORDER MAY LEAD TO CRIMINAL PROSECUTION**

ANY INCURSION INTO THE PROTECTED AREA MUST BE WITH THE WRITTEN PERMISSION OF THE LOCAL PLANNING AUTHORITY

Appendix 2 – Site Supervision / Site Visit Record

Arboricultural Consultant's Development Site Monitoring Form

Arboricultural Consultant's Details:	
Company name/address	
Consultant's name	
tel: fax: mob:	
Development site address:	Local Planning Authority (LPA):
LPA Case Officer:	LPA Tree Officer:
Developer's details:	
Company name/address	
Developer's name	
tel: fax: mob:	

Stage of development (✓): **Pre-development works** **Development works** **Post-development works**

Tree works <input type="checkbox"/>	Demolition <input type="checkbox"/>	Rectifying tree damage/pruning <input type="checkbox"/>
Protective fencing/tape <input type="checkbox"/>	Grading/muck away <input type="checkbox"/>	Hard landscaping/walls/drives <input type="checkbox"/>
Fencing signage <input type="checkbox"/>	Placing portacabin <input type="checkbox"/>	Removal of protective fencing etc <input type="checkbox"/>
Ground protection <input type="checkbox"/>	Excavations/services <input type="checkbox"/>	Soft landscaping <input type="checkbox"/>
Temporary haul road <input type="checkbox"/>	Construction works <input type="checkbox"/>	Special surfacing <input type="checkbox"/>
		Tree planting <input type="checkbox"/>

Findings:	
Action taken:	
Further action required/recommendations:	
Comments:	
Date of site visit:	Date of next site visit:

Date sent to Local Planning Authority Case Officer _____

Appendix 3 – Reference Material

- APN 12 'Through the Trees to Development' 2007
- British Standard 3998: 2010 'Recommendations for Tree Work'
- British Standard 4428: 1989 'Code of Practice for General Landscape Operations (excluding hard surfaces)'
- British Standard 5837: 2012 'Trees in relation to design, demolition and construction – Recommendations'
- DETR 'Tree Preservation Orders: A Guide to the Law and Good Practice'
- NHBC Chapter 4.2 'Building Near Trees' 2011
- National Joint Utilities Group NJUG Volume 4 'Guidelines For The Planning, Installation And Maintenance Of Utility Apparatus In Proximity To Trees (Issue 2)' 2007
- Countryside and Rights of Way Act 2000
- Conservation of Habitats and Species Regulations 2010
- Health and Safety at Work Act 1974
- Management of Health and Safety at Work Regulations 1999
- The Town & Country Planning Act 1990, The Town and Country Planning (Trees) Regulations 1999 (as amended), The Planning (Listed Buildings & Conservation Areas) Act 1990
- Wildlife and Countryside Act 1981

Common causes of Tree Death

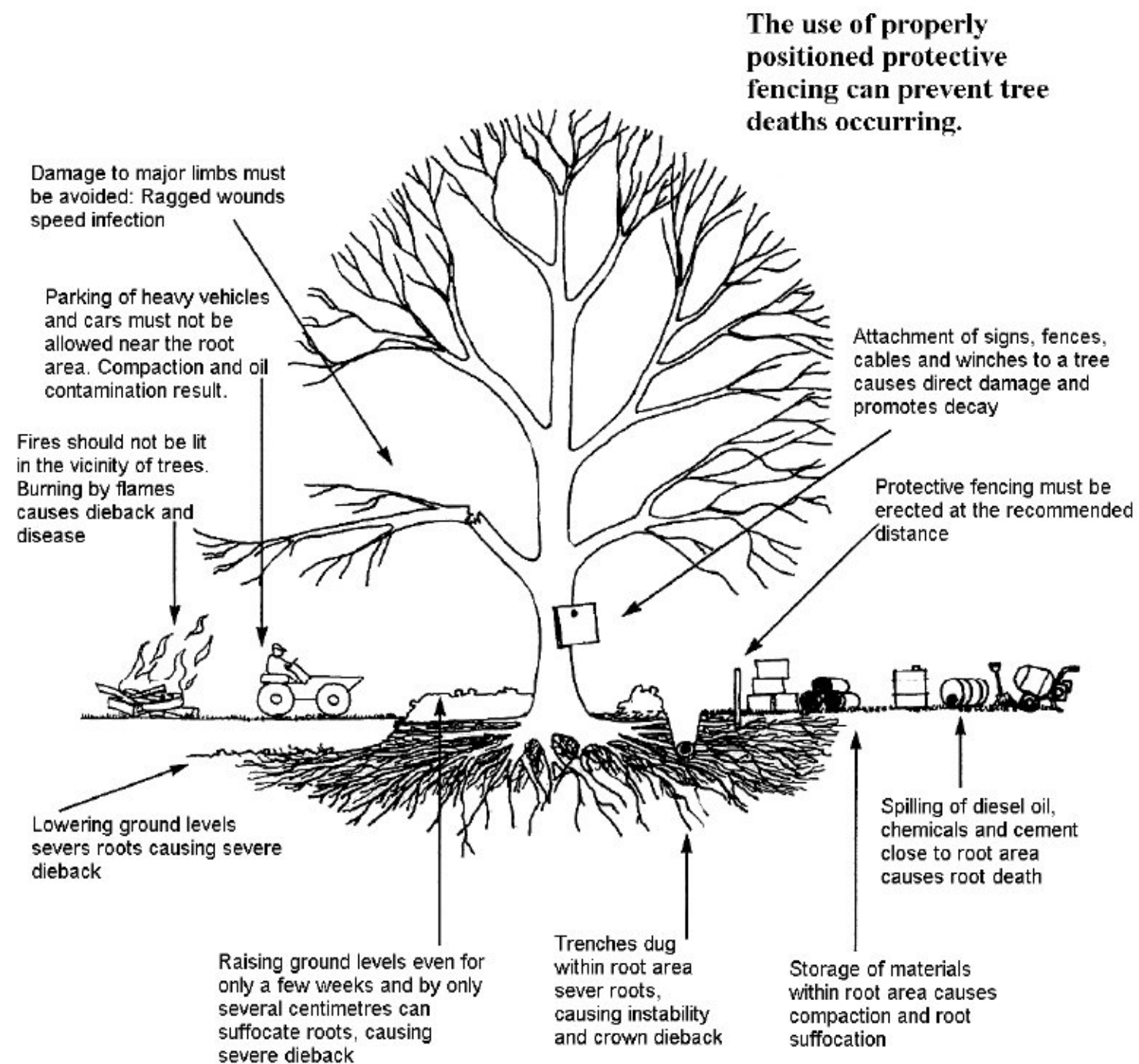

Please use copies of this as an on-site poster for personnel



Construction and Trees

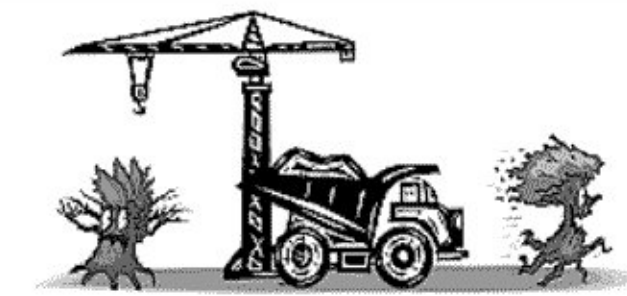

Why Is Fencing Erected Around Trees?

1. The major cause of damage to trees on construction sites is due to **soil compaction**.
2. Roots use the spaces between soil particles to obtain Oxygen, Water and Nutrients.
3. Heavy plant and machinery compresses (compacts) the soil, squashing out the air spaces and preventing root function.
4. A compacted soil structure will stay compacted.
5. Consequently the tree suffers and will show signs of branch die-back.
6. Symptoms such as die-back may take several years to appear.
7. Soil compaction over roots can be prevented by maintaining a fenced exclusion zone over the tree roots.
8. The exclusion zone distance is calculated using British Standard 5837.
9. Protective Fencing is installed at the calculated distance.
10. Protective Fencing is a condition of planning approval, if it is removed or repositioned the construction firm is in breach of a condition and may be subjected to legal action.

Notes:
Do not scale from this drawing
All dimensions to be checked on site

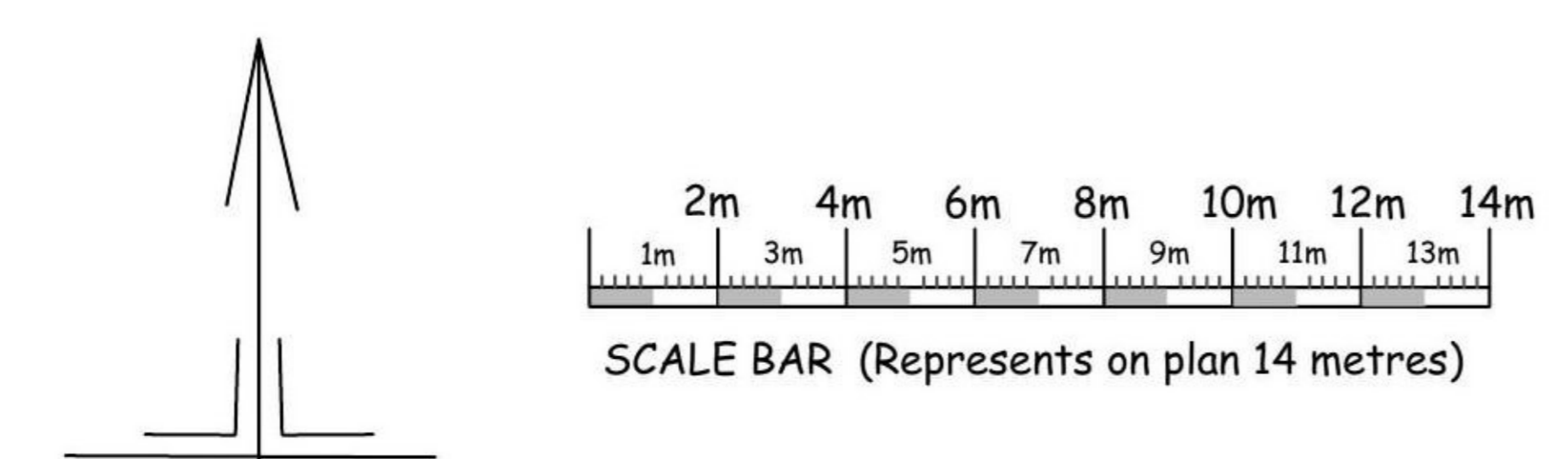

TREE REMOVAL AND RETENTION PLAN

- Tree to be retained
- Tree to be removed



Title **Tree Removal And Retention Plan**

Job **2,4 &6 Woodside**

Scale **1:200 @ A1**

Date **08.04.2021**

Drm **SB**

Dwg No **001**

Chartwell Tree Consultants Ltd
2 Greencroft Cottage
Farley Lane
Westerham
Kent
TN16 1UB

Tel: 01959 569 280
sam@chartwelltreeconsultants.co.uk

Notes:
Do not scale from this drawing
All dimensions to be checked on site

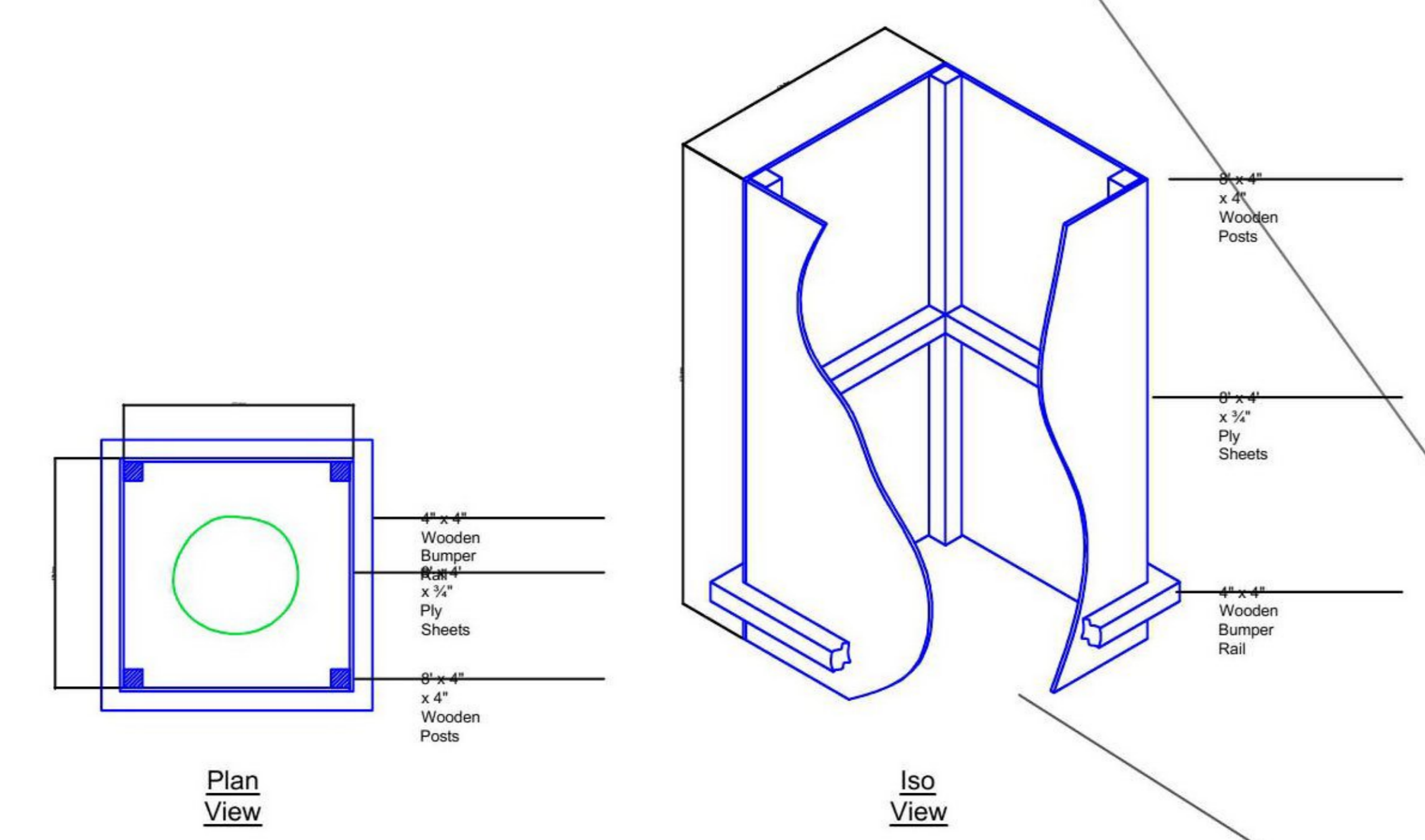
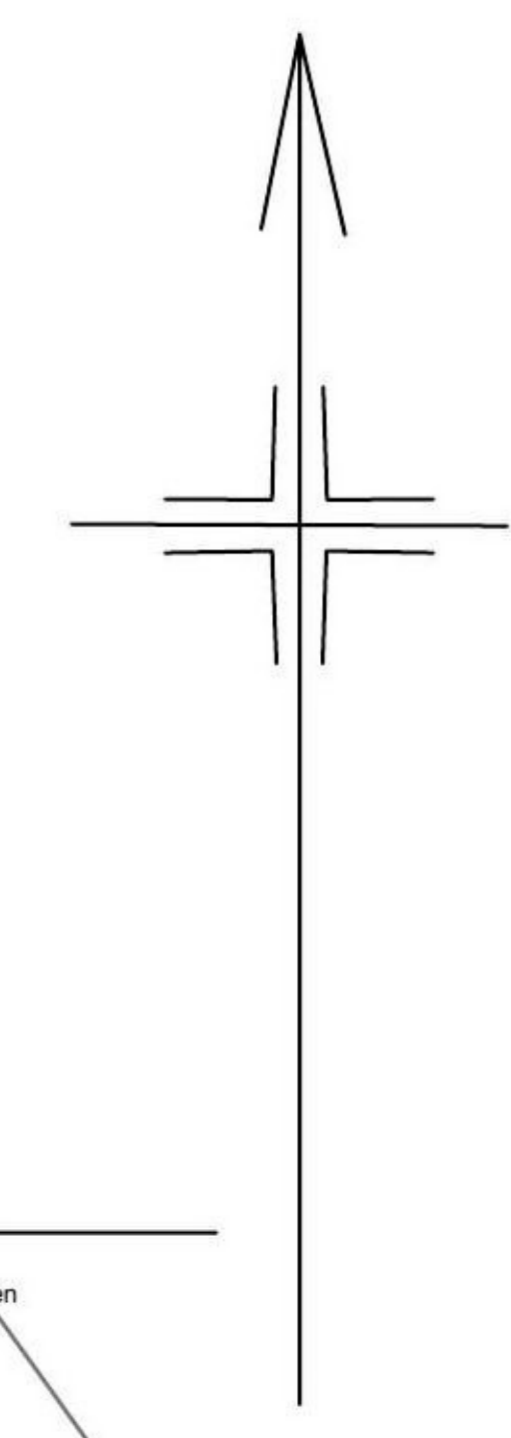
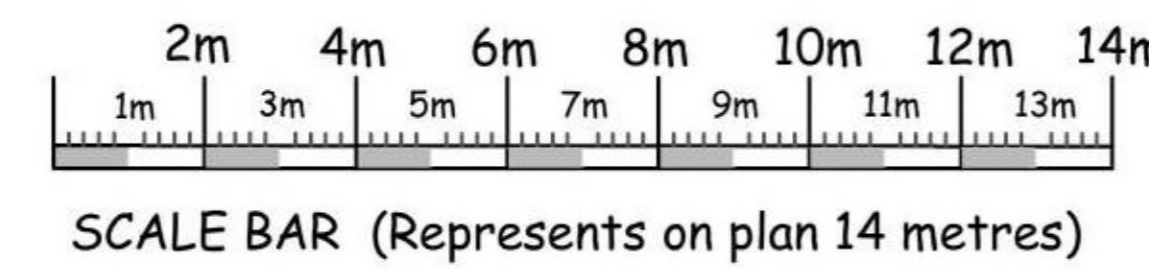

Fencing to be moved at end of build to finish of low-invasive hard landscaping

Hand dug holes for fences and gravel boards within RPA's.

New hard surfacing (sub-base) and ground protection to be installed before any construction works commence

Replacement retaining wall to be steel H beam and sleeper wall - no roots over 2.5cm to be severed without Arboricultural supervision

Replacement hard surfacing for pool to be porcelain atop pods, with a no fines subbase

Drainage within RPA's to be trenchless methods

TREE PROTECTION PLAN

- Tree to be retained
- Tree protection fencing
- CEZ** Construction Exclusion Zone
- Ground protection measures required
- Low-invasive/Precautionary area. Hand excavation, Cellwebb driveway and retaining walls
- Low-invasive/Precautionary area. Special engineered foundations

Title **Tree Protection Plan**
Job **2,4 & 6 Woodside**
Scale **1:200 @ A1**
Date **08.04.2021**
Drm **SB**
Dwg No **003**

Chartwell Tree Consultants Ltd
2 Greencroft Cottage
Farley Lane
Westerham
Kent
TN16 1UB

Tel: 01959 569 280
sam@chartwelltreeconsultants.co.uk

