

SECTION AA 1:20@A1

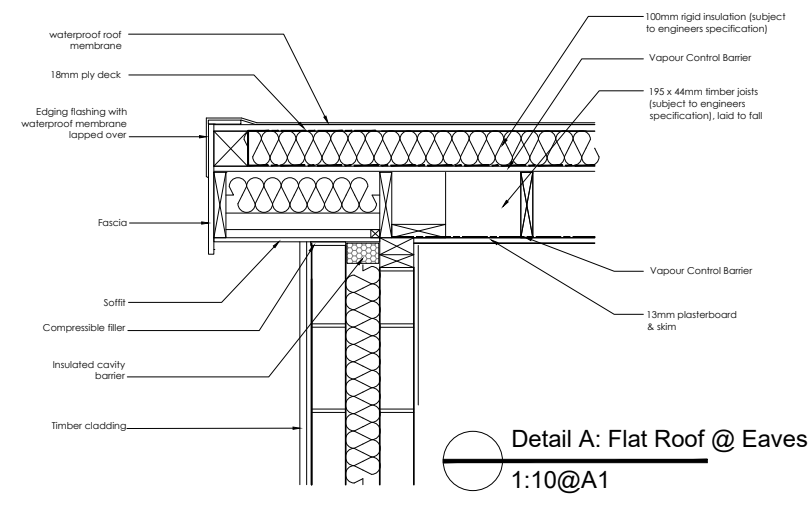

Detail A: Flat Roof @ Eaves
1:10@A1

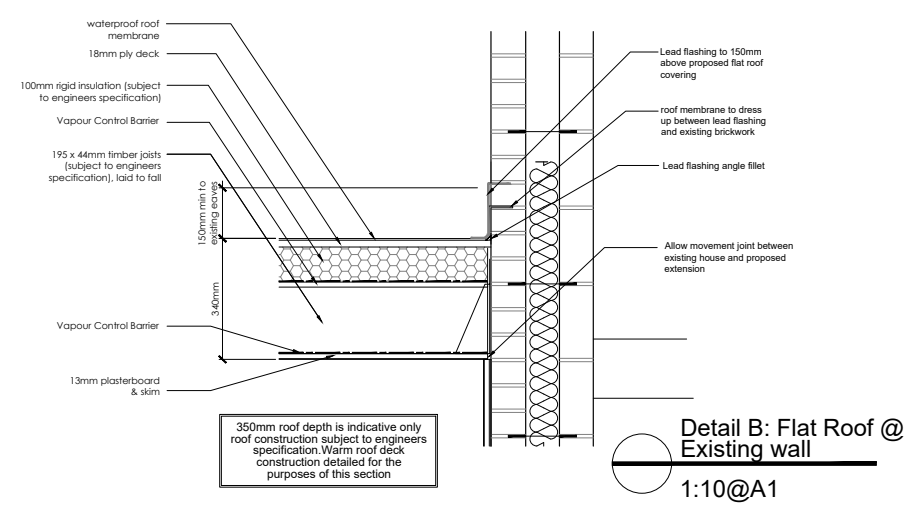

Detail B: Flat Roof @ Existing wall
1:10@A1

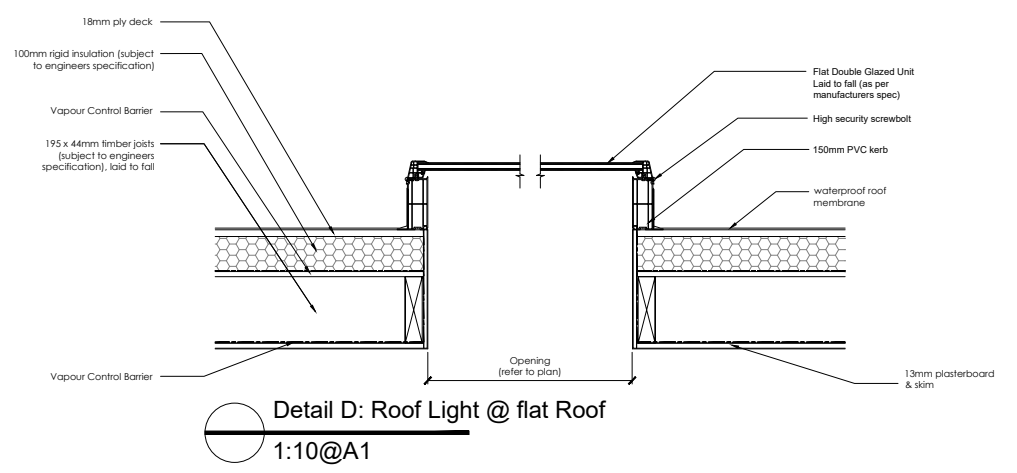

Detail D: Roof Light @ flat Roof
1:10@A1

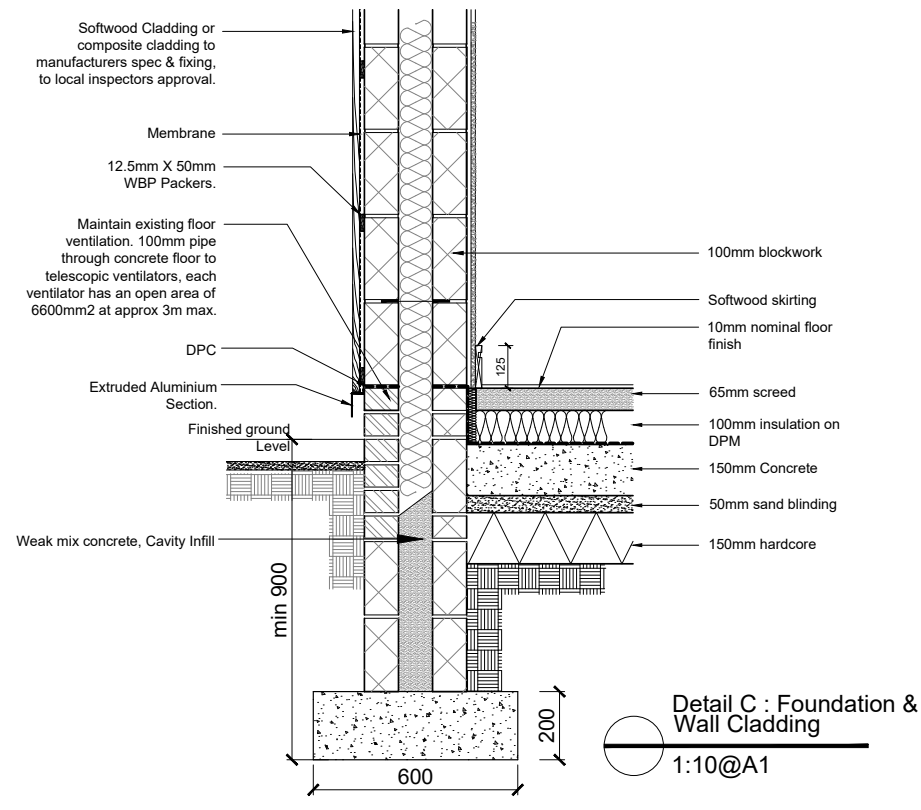

Detail C: Foundation & Wall Cladding
1:10@A1

Notes:

1. Contractor/sub-contractors to verify all dimensions on site before commencing work. Skribbld is to be notified of any discrepancies in dimensions and setting out of work prior to starting on site.
2. Copyright of design shown is retained by this office. All rights reserved. This drawing must not be reproduced without prior permission.
3. Do not scale from the drawings.
4. All dimensions are in millimeters unless noted otherwise. All dimensions to be verified on site & approved by the engineer/contractor.
5. This drawing should be read in conjunction with the other relevant architectural, structural, mechanical and electrical drawings and all relevant sections of the specifications.

REV:	DESCRIPTION:	BY:	DATE:
STATUS:	BUILDING REGS		

SKRIBBLD SKRIBBLD
Manchester, UK
+44 77260 22288
www.skribbld.com
info@skribbld.com

CLIENT: Ethan Ticehurst
9 Catchdale Close
Blackley
Manchester

TITLE: Proposed Section AA & Details

SCALE AT A1:	DATE:	DRAWN:	CHECKED:
Varies@A1	01.12.20	SM	HS
PROJECT NO:	DRAWING NO:	REVISION:	
2006	BR-DT-001	00	