

EXISTING GROUND FLOOR PLAN - 1:100 @A3

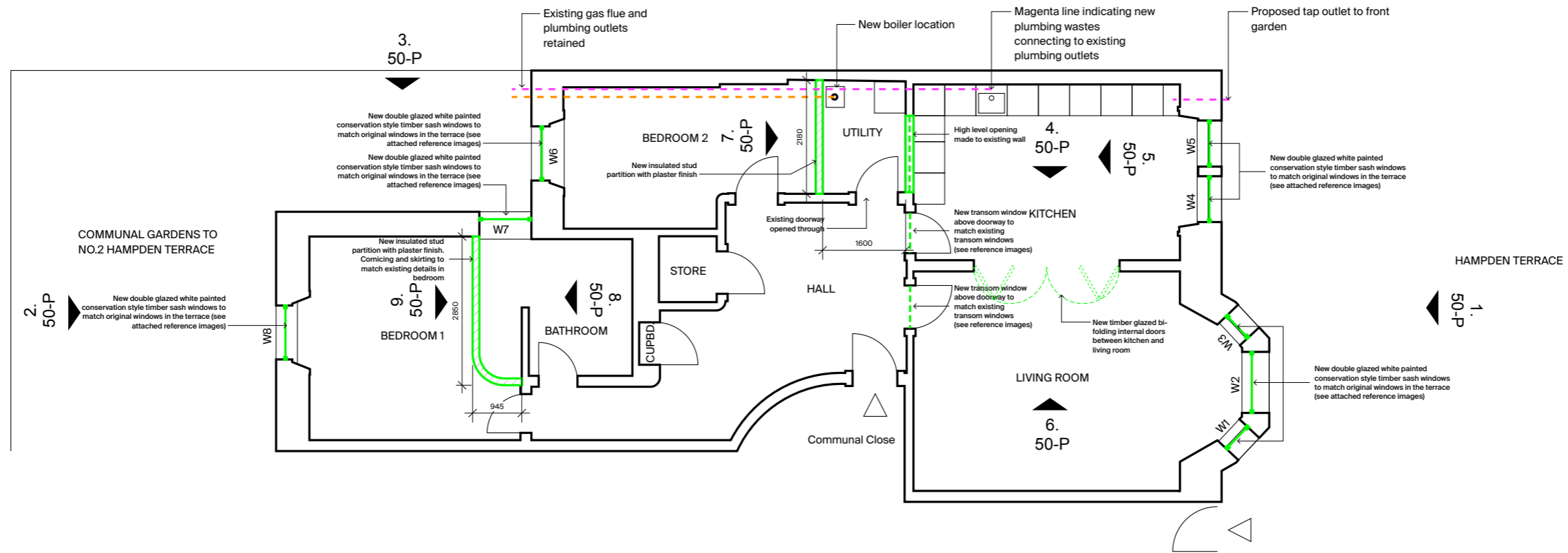

PROPOSED GROUND FLOOR PLAN - 1:100 @A3

NOTES
/

PROJECT
0/2 2 HAMPDEN TERRACE

CLIENT
OSCAR MURRAY +
PHOEBE WILLISON
DRAWING TITLE
GROUND FLOOR PLAN
EXISTING + PROPOSED

DRAWING NUMBER
2HT-GA-00-E+P

SCALE
1:100 @ A3

STATUS
PLANNING

REVISION
A

ISSUE DATE
30.03.21

Do not scale from this drawing for construction purposes. All dimensions to be checked on site. Any ambiguities or discrepancies in dimensions outside of stated tolerances be reported to architect before work commences. All dimensions in millimeters unless otherwise stated.

OSCAR MURRAY
0/2 2 HAMPDEN TERRACE
G42 9XG
GLASGOW
+44 (0) 7859 192030
OSCARJMURRAY@GMAIL.COM

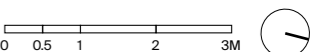

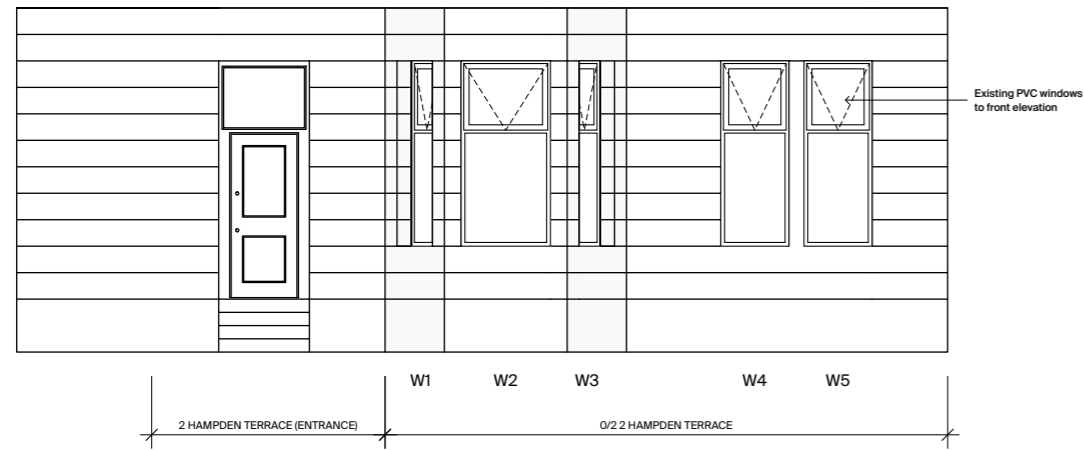

1. FRONT ELEVATION - EXISTING

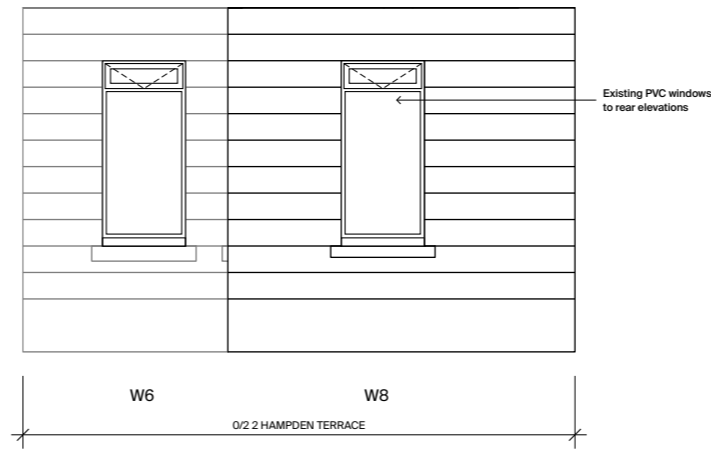

2. REAR ELEVATION - EXISTING

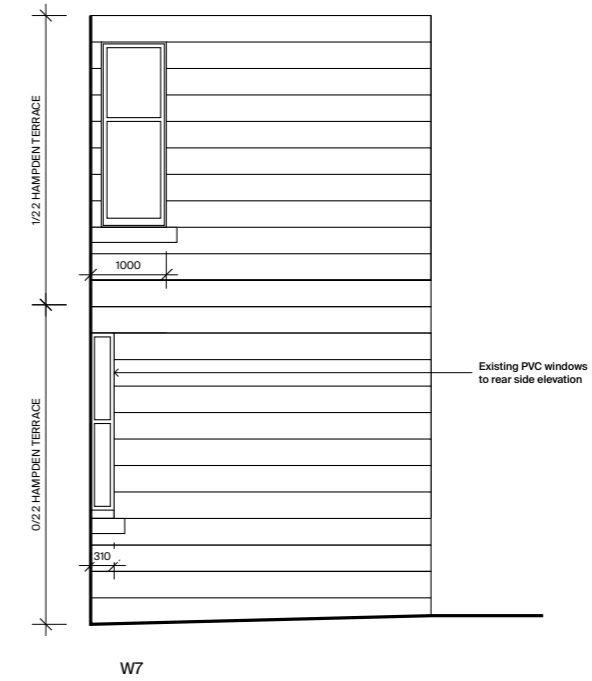

3. SIDE ELEVATION - EXISTING

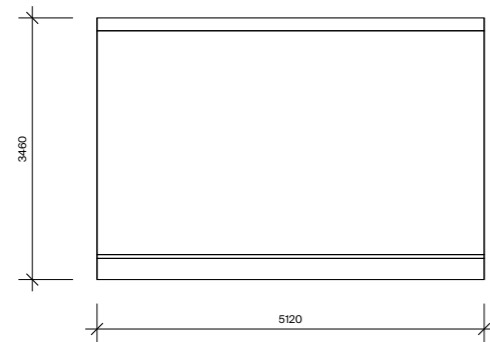

4. (BEDROOM 2) INTERNAL DOOR ELEVATION - EXISTING

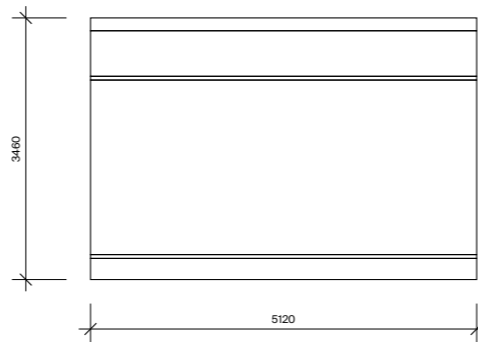

5. (LIVING ROOM) INTERNAL DOOR ELEVATION - EXISTING

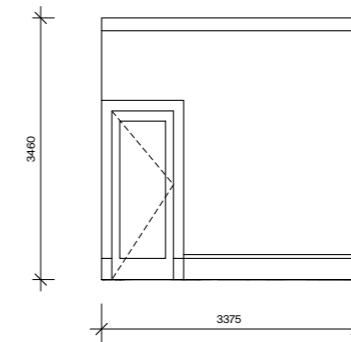

6. (BEDROOM 2) INTERNAL HIGH LEVEL WINDOW ELEVATION - EXISTING

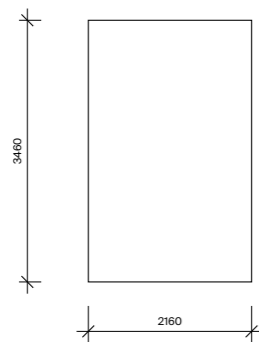

7. (KITCHEN) INTERNAL HIGH LEVEL ELEVATION - EXISTING

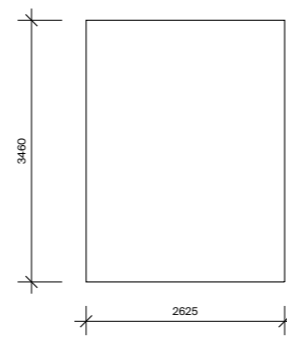

8. (BATHROOM) INTERNAL ELEVATION - EXISTING

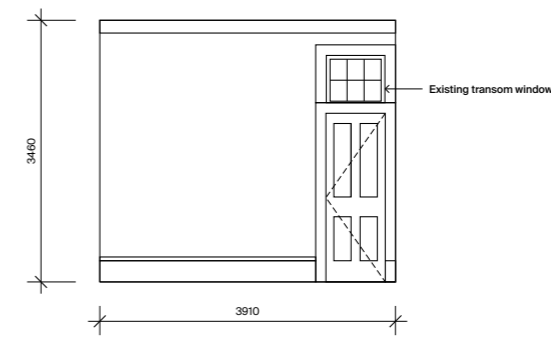

9. (BEDROOM 1) INTERNAL ELEVATION - EXISTING

NOTES
/

PROJECT
0/2 2 HAMPDEN TERRACE

CLIENT
OSCAR MURRAY +
PHOEBE WILLISON
DRAWING TITLE
ELEVATIONS
EXISTING

DRAWING NUMBER
2HT-GA-50-E

SCALE
1:100 @ A3

STATUS
PLANNING

REVISION
/

ISSUE DATE
28.03.21

Do not scale from this drawing for construction purposes. All dimensions to be checked on site. Any ambiguities or discrepancies in dimensions outside of stated tolerances be reported to architect before work commences. All dimensions in millimeters unless otherwise stated.

OSCAR MURRAY
0/2 2 HAMPDEN TERRACE
G42 9XG
GLASGOW
+44 (0) 7859 192030
OSCARJMURRAY@GMAIL.COM

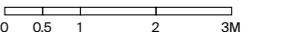

NOTES
/

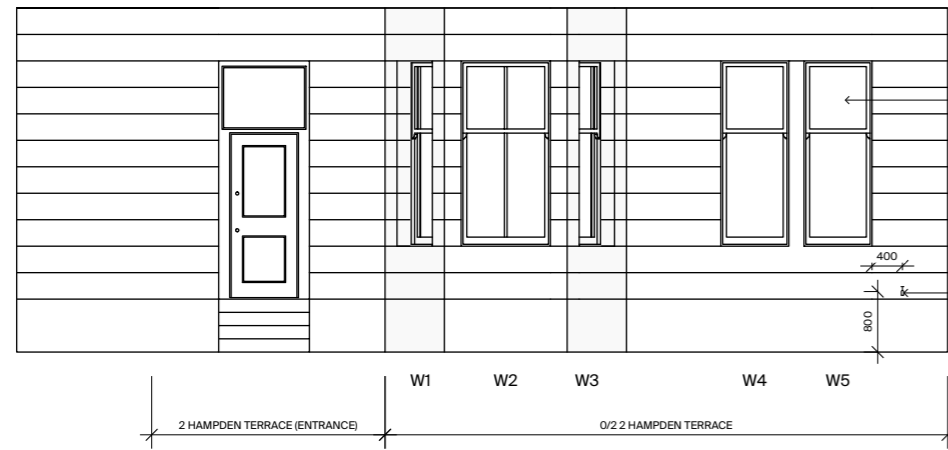

New white painted timber sash double glazed windows to match existing design and proportions of original windows of terrace

New brass external tap for garden house attachment 800mm above ground

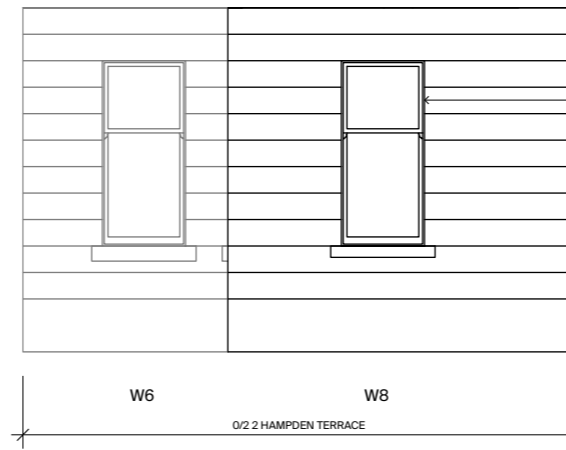

New white painted timber sash double glazed windows to match existing design and proportions of original windows of terrace

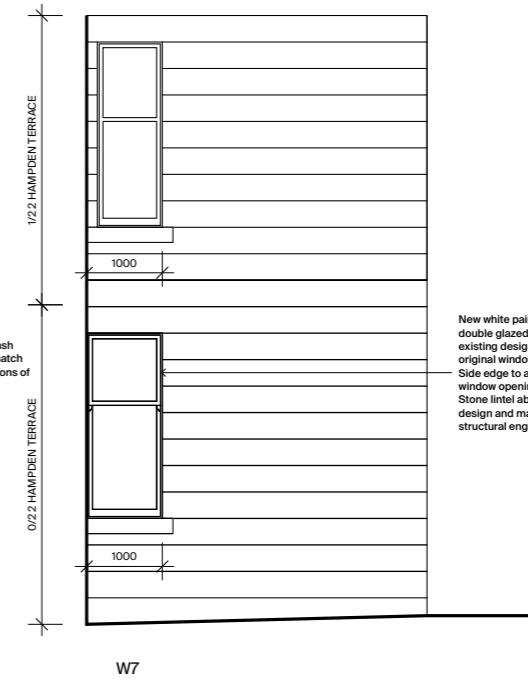

New white painted timber sash double glazed windows to match existing design and proportions of original windows of terrace. Side edge to align with existing window opening above. Stone lintel above to match existing design and material (sandstone) to structural engineer's design

1. FRONT ELEVATION - PROPOSED

2. REAR ELEVATION - PROPOSED

3. SIDE ELEVATION - PROPOSED

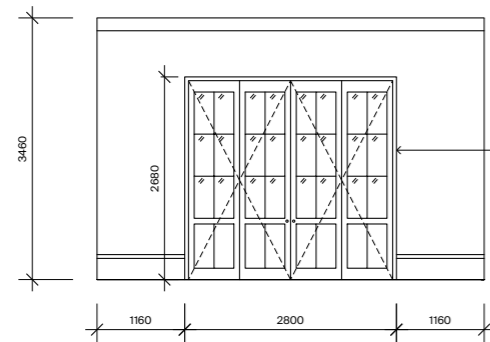

New glazed timber panelled bi-folding internal doors with white painted timber architrave

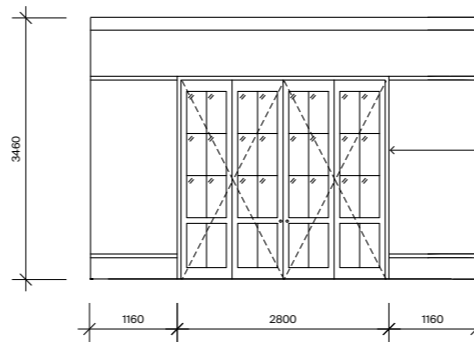

New glazed timber panelled bi-folding internal doors with white painted timber architrave

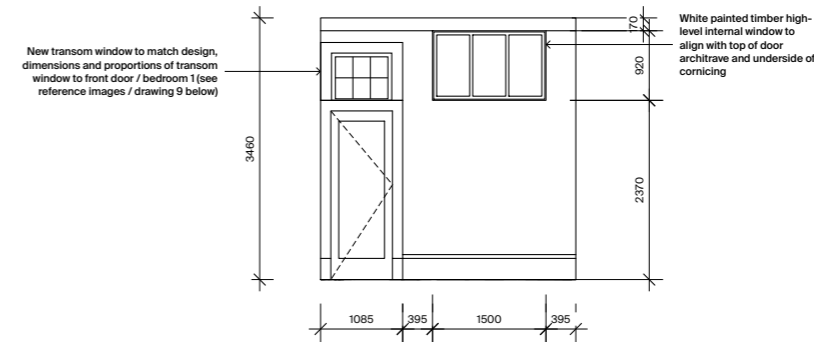

New transom window to match design dimensions and proportions of transom window to front door / bedroom 1 (see reference images / drawing 9 below)

White painted timber high-level internal window to align with top of door architrave and underside of cornice

4. (KITCHEN) INTERNAL DOOR ELEVATION - PROPOSED

5. (LIVING ROOM) INTERNAL DOOR ELEVATION - PROPOSED

6. (KITCHEN) INTERNAL HIGH LEVEL WINDOW ELEVATION - PROPOSED

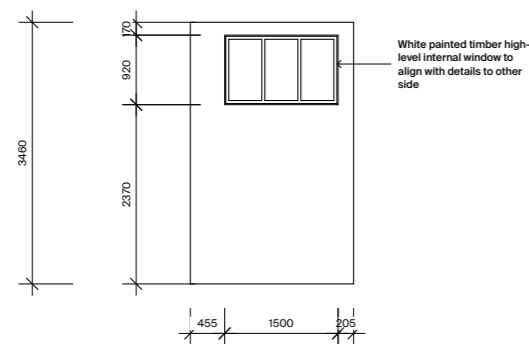

White painted timber high-level internal window to align with details to other side

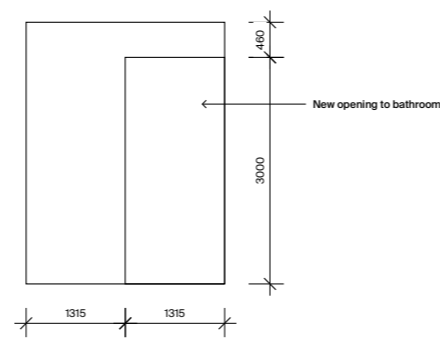

New opening to bathroom

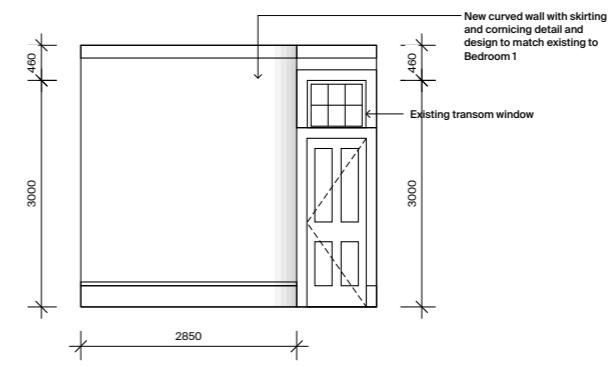

New curved wall with skirting and cornice detail and design to match existing to Bedroom 1

Existing transom window

7. (BEDROOM 2) INTERNAL HIGH LEVEL ELEVATION - PROPOSED

8. (BATHROOM) INTERNAL ELEVATION - PROPOSED

9. (BEDROOM 1) INTERNAL ELEVATION - PROPOSED

PROJECT
0/2 2 HAMPDEN TERRACE

CLIENT
OSCAR MURRAY +
PHOEBE WILLISON
DRAWING TITLE
ELEVATIONS
PROPOSED

DRAWING NUMBER
2HT-GA-50-P

SCALE
1:100 @ A3

STATUS
PLANNING

REVISION
A

ISSUE DATE
30.03.21

Do not scale from this drawing for construction purposes. All dimensions to be checked on site. Any ambiguities or discrepancies in dimensions outside of stated tolerances be reported to architect before work commences. All dimensions in millimeters unless otherwise stated.

OSCAR MURRAY

0/2 2 HAMPDEN TERRACE
G42 9XG
GLASGOW

+44 (0) 7859 192030
OSCARJMURRAY@GMAIL.COM

0 0.5 1 2 3M