

SITE ARRANGEMENT AS EXISTING. SCALE : 1:100

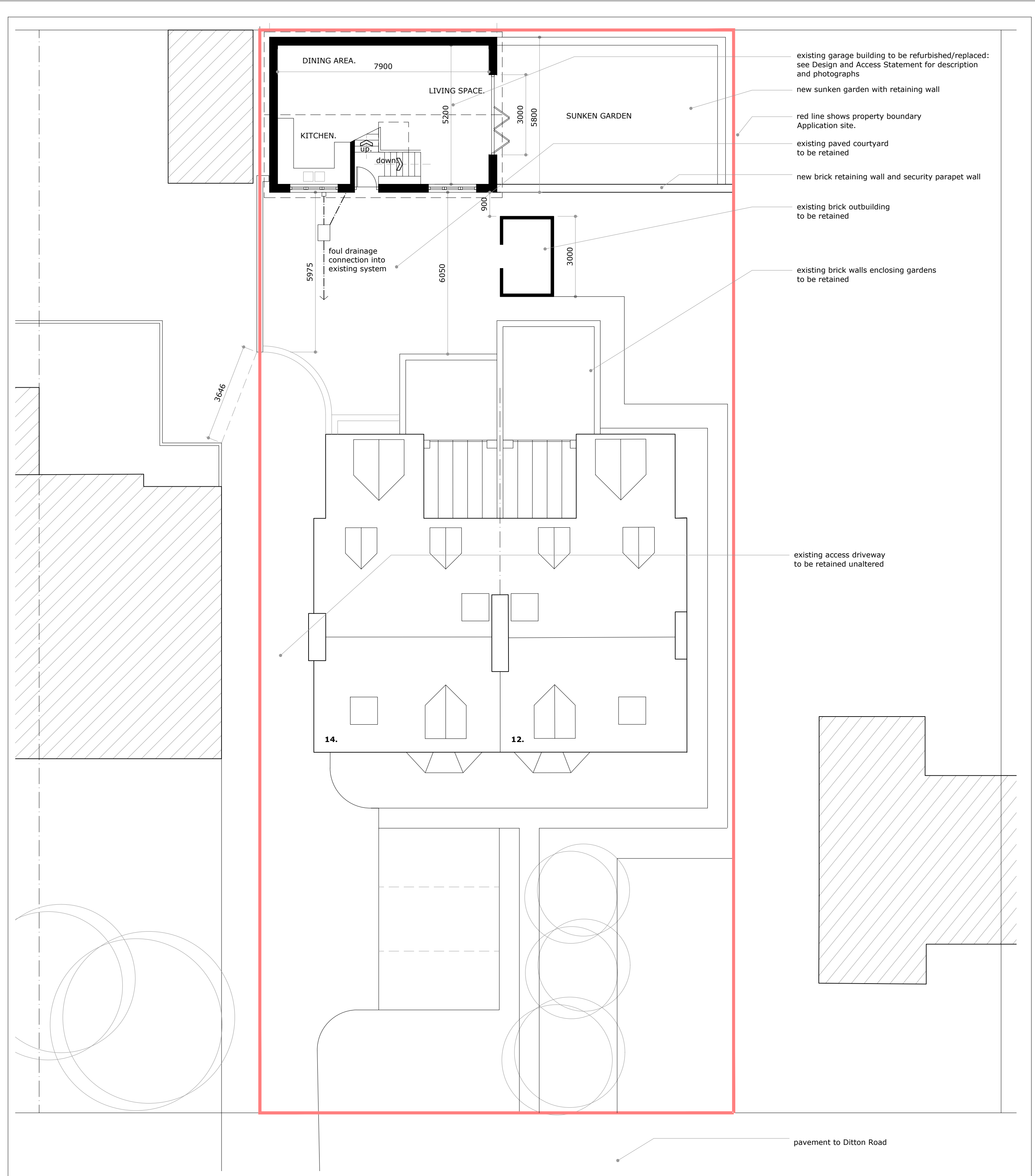

SITE ARRANGEMENT AS PROPOSED. SCALE : 1:100

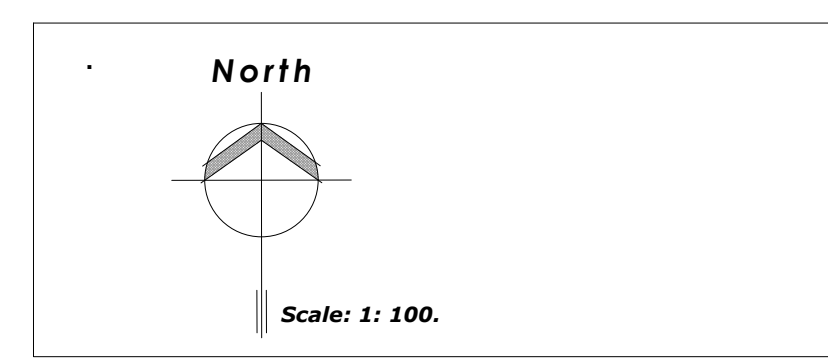

**NOTE:**  
 ALL EXISTING AND PROPOSED DIMENSIONS AND LEVELS MUST BE VERIFIED ON-SITE BEFORE COMMENCING WORK AND ANY DISCREPANCIES OR OMISSIONS NOTIFIED TO MCLAREN ASSOCIATES. ALL BOUNDARIES SUBJECT TO SITE SURVEY. THIS DRAWING MUST NOT BE SCALED.

**MCLAREN ASSOCIATES**  
 architectural and development consultants

MCLAREN ASSOCIATES  
 24-28 ST LEONARDS ROAD  
 WINDSOR  
 BERKSHIRE SL4 3BB  
 contact@mclaren-associates.com

**12-14 DITTON ROAD CHESSINGTON**

**PROPOSED DEVELOPMENT AT:**  
 12-14 DITTON ROAD  
 SURBITON  
 KT6 6QZ

SITE ARRANGEMENT  
 AS EXISTING  
 AS PROPOSED

<b>SCALE:</b> 1:100 [A1]	<b>AUTHOR :</b> DCP	<b>DATE:</b> JANUARY 2021
<b>PROJECT:</b> <b>1032</b>	<b>DRAWING:</b> <b>22</b>	<b>REVISION:</b> <b>A</b>