

A-A DOOR HEAD SECTION

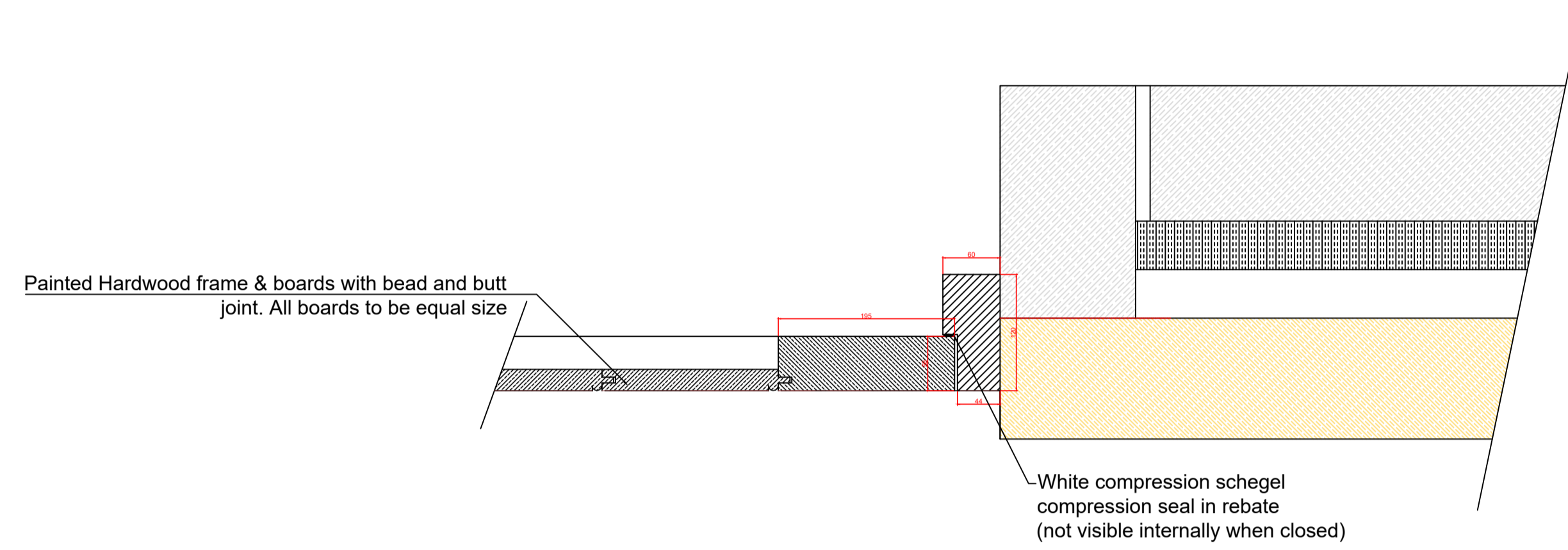

C-C DOOR JAMB SECTION

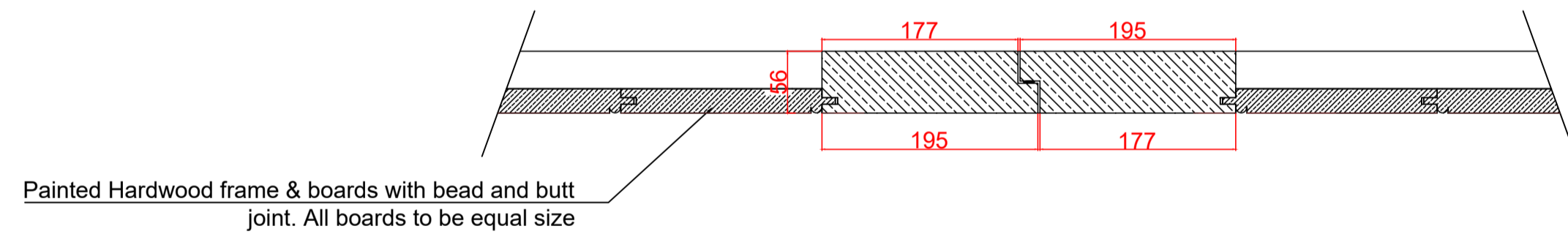

B-B MEETING SYTLE SECTION

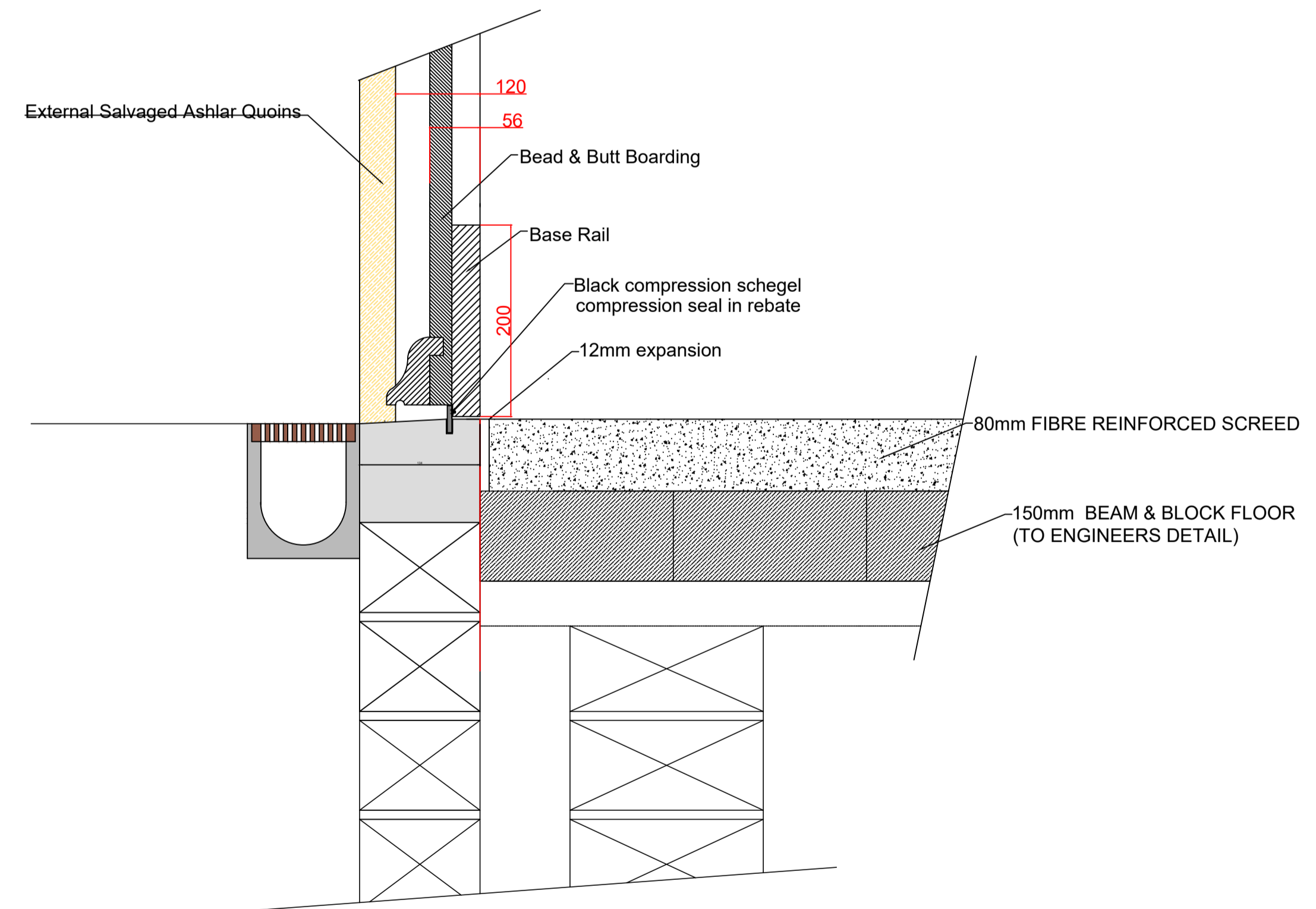

D-D TYPICAL GARAGE DOOR CILL DETAIL

This drawing is protected by copyright and remains the property of J Rigg construction. It must not be reproduced or copied without first obtaining written consent.

This drawing must not be relied upon for construction purposes and it is the contractors responsibility to confirm measurements on site. Any discrepancies must be highlighted immediately to J Rigg construction.

DRAWING TYPE	
<input checked="" type="checkbox"/>	FOR INFORMATION ONLY
<input type="checkbox"/>	PRE-CONSTRUCTION
<input type="checkbox"/>	CONSTRUCTION ISSUE
<input type="checkbox"/>	AS BUILT

REVISION NOTES:	



Client	MR & MRS B. WICKENS
Project	PUDLICOTE HOUSE
Date	16.02.21
Scale	1:5 @ A1
Revision	
Drawing details	GARAGE DOOR SECTIONS
Drawing number	JRC/PH/003