



NOTES:

1. DO NOT SCALE FROM THIS DRAWING.
2. VARIOUS DESIGN SERIES OMITTED FOR CLARITY.
3. THIS DRAWING SHOULD ONLY BE USED FOR ITS INTENDED PURPOSE.
4. DIMENSIONS SHOWN ARE IN METRES UNLESS OTHERWISE STATED.

KEY:

- FORWARD WHEEL PATH
- FORWARD VEHICLE ENVELOPE
- REVERSE WHEEL PATH
- REVERSE VEHICLE ENVELOPE
- APPROXIMATE LAND OWNERSHIP BOUNDARY

VEHICLE PROFILE:

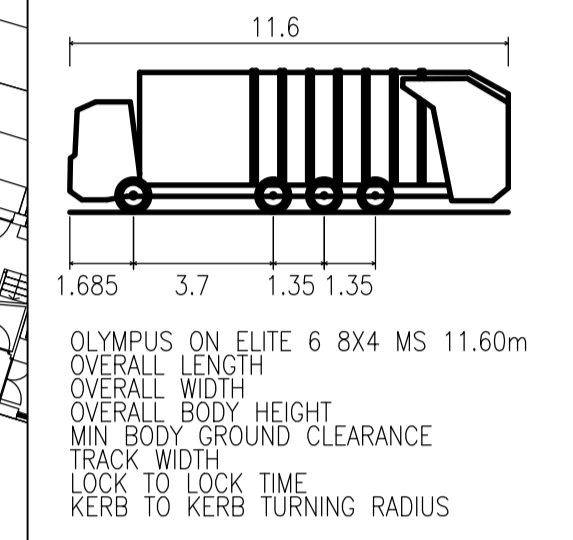

PO1	FIRST ISSUE	HG	RS	31.03.21
REV:	AMENDMENTS:	DRN:	CHK:	DATE:

Project:
MILL LANE
BOLSOVER

Drawing title:
PROPOSED
VEHICLE TRACKING
SHEET 1 OF 1

Client:
WOODHEAD GROUP LTD.

Drawing number:
100412_01_000_02

Revision:	Sheet size:	Scale:
PO1	A1	1:1000
Drawn by:	Checked by:	Date:
HG	RS	31.03.2021

Status:
PRELIMINARY

Dice
+44 (0) 1159 528 752
info@diceconsult.co.uk
diceconsult.co.uk
Design
Infrastructure
Consulting
Engineers

File Location: C:\Shared\office\Dice - jobs\100412 Mill Lane, Bolsover\01 - drawings\01 - drawings\01 - ciba\03 - general\100412_01_000_02 vehicle tracking.dwg
Printed: 17.05.2021