

Existing Ground Floor Plan 1:100

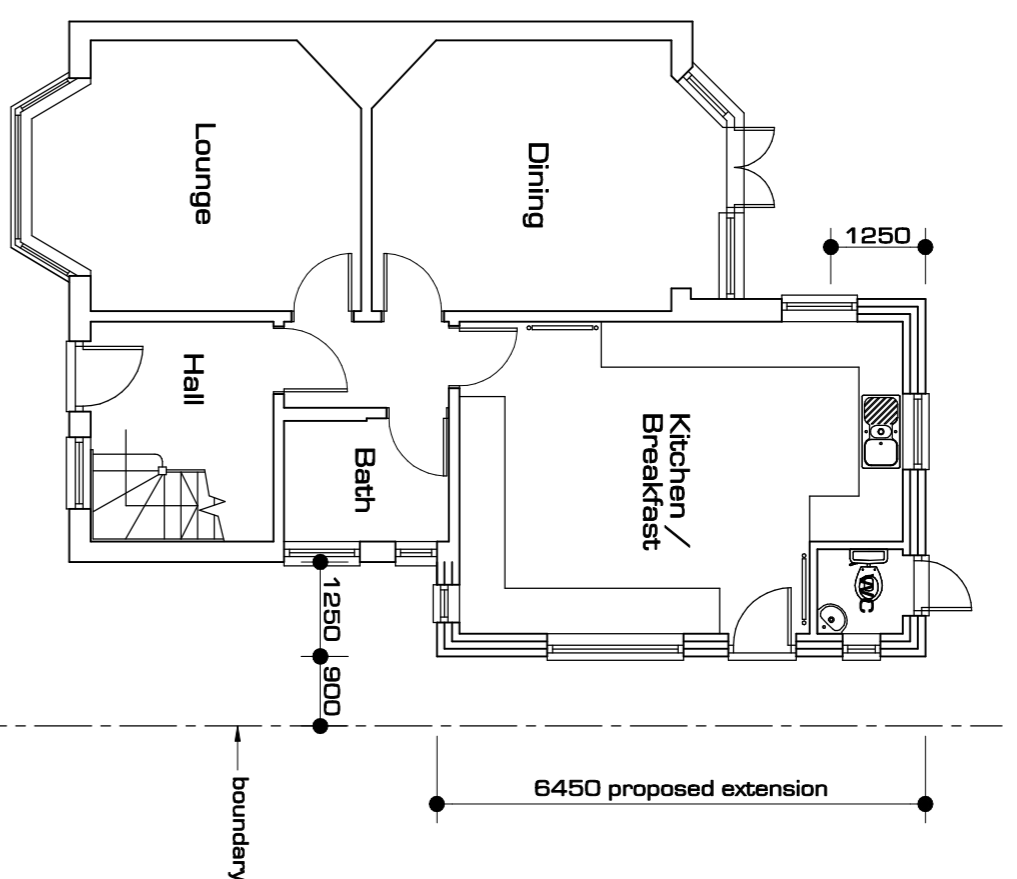

Proposed Ground Floor Plan

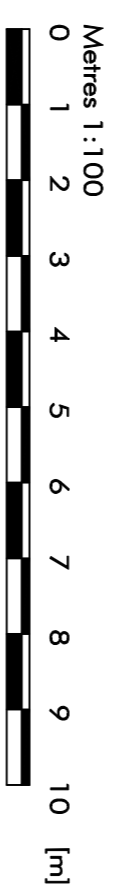
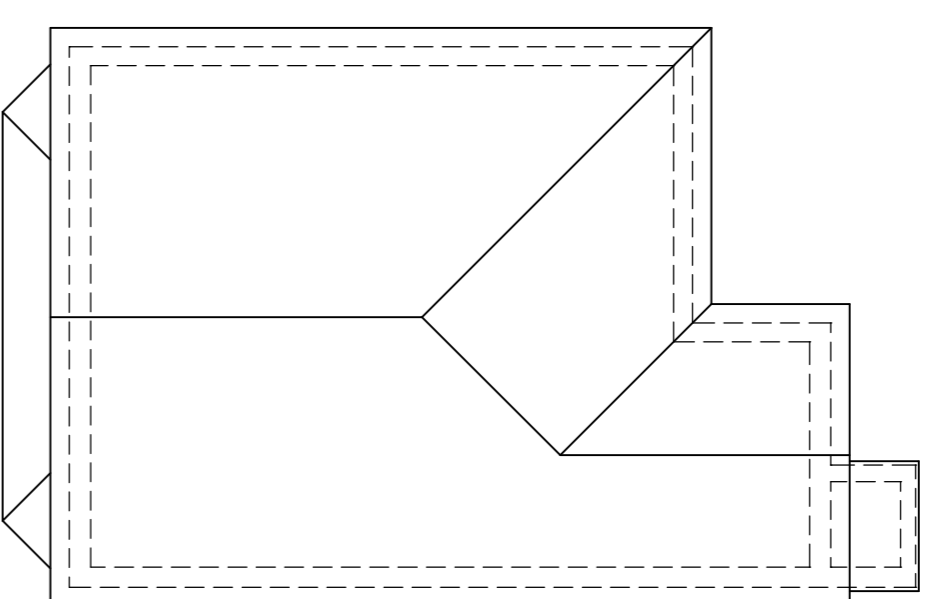

Existing Roof Plan

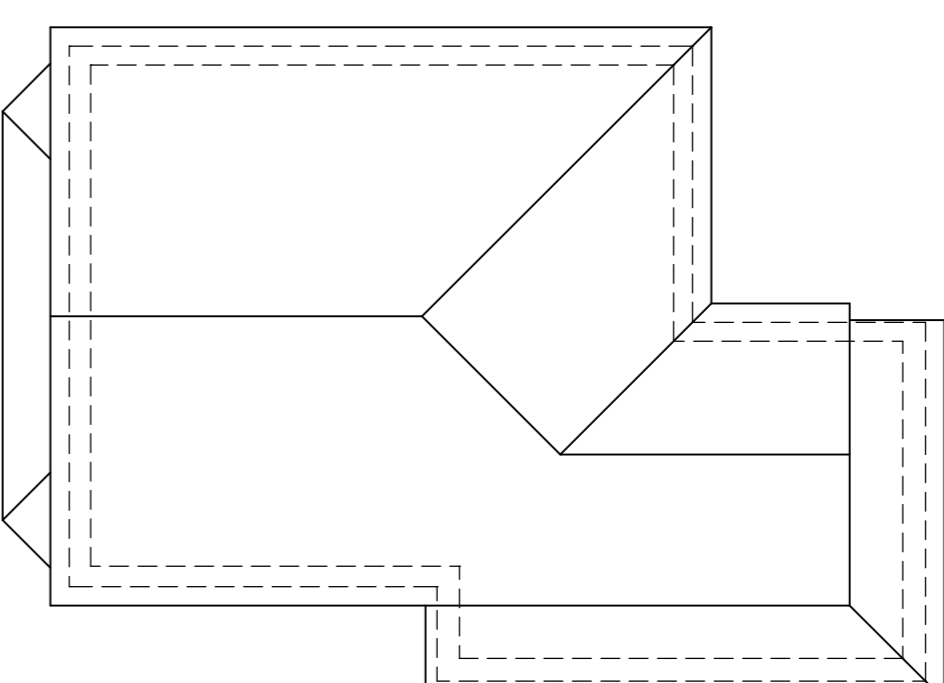

Proposed Roof Plan



©Crown Copyright and database rights 2021 OS Licence no. 100041041

Site Location 1:1250

M 1:1250

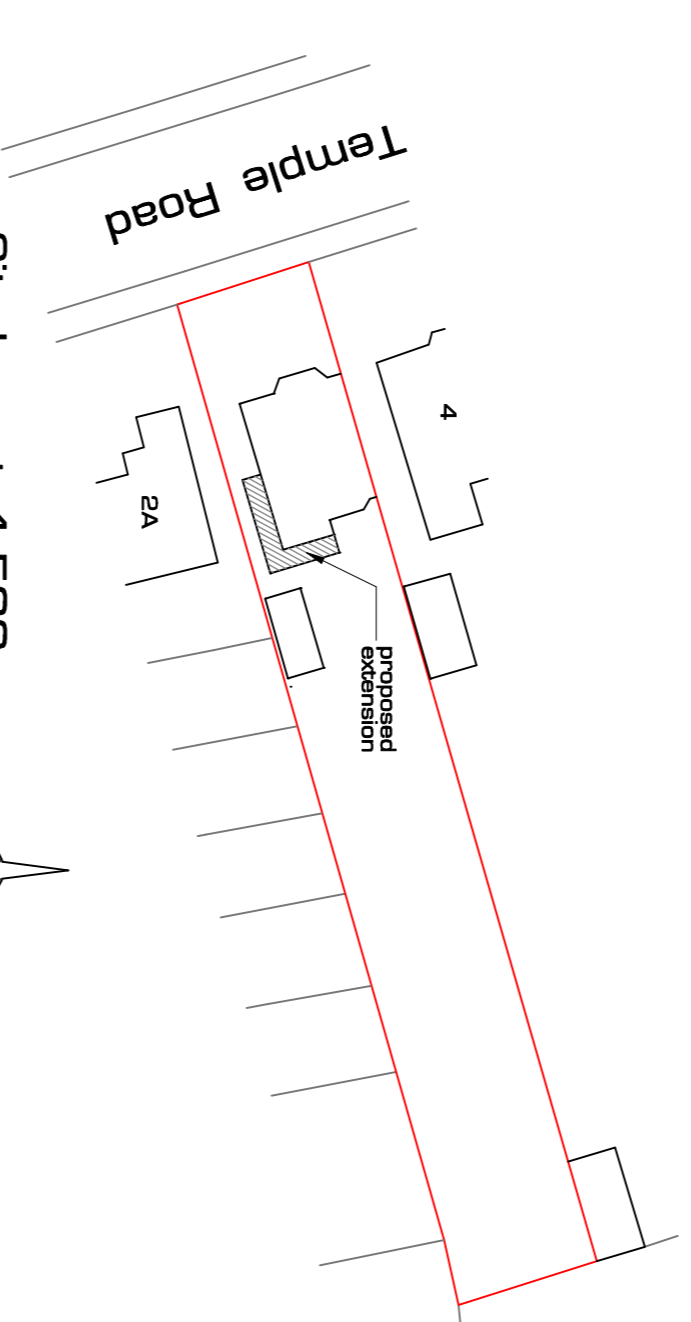
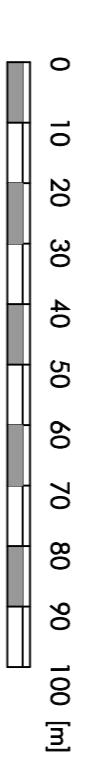

Site Layout 1:500

M 1:500

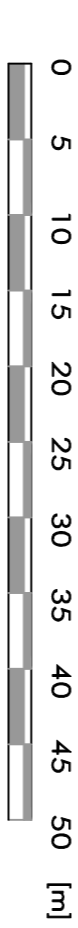

Proposed Front Elevation 1:100

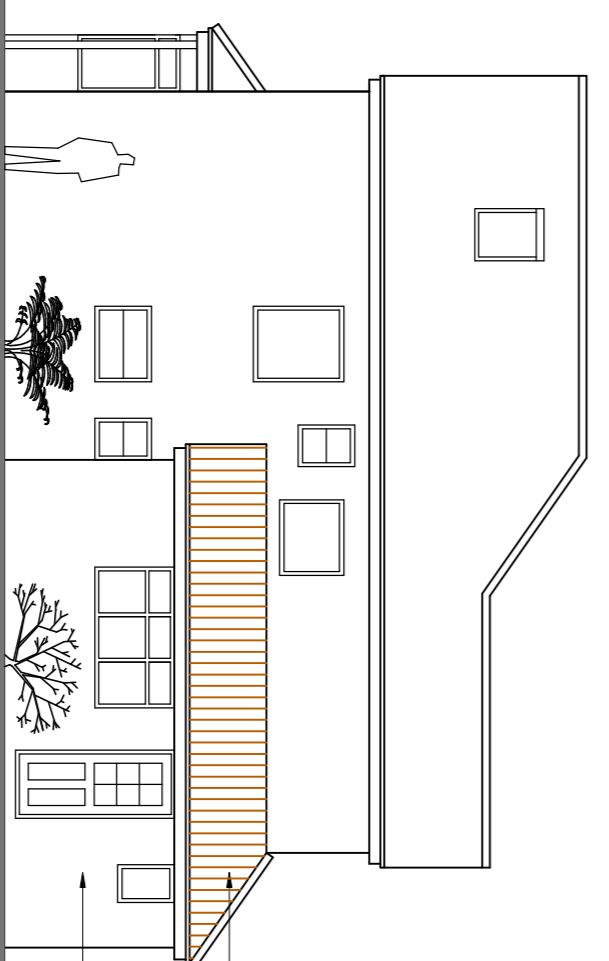
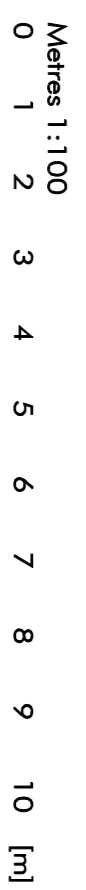

Proposed Side Elevation

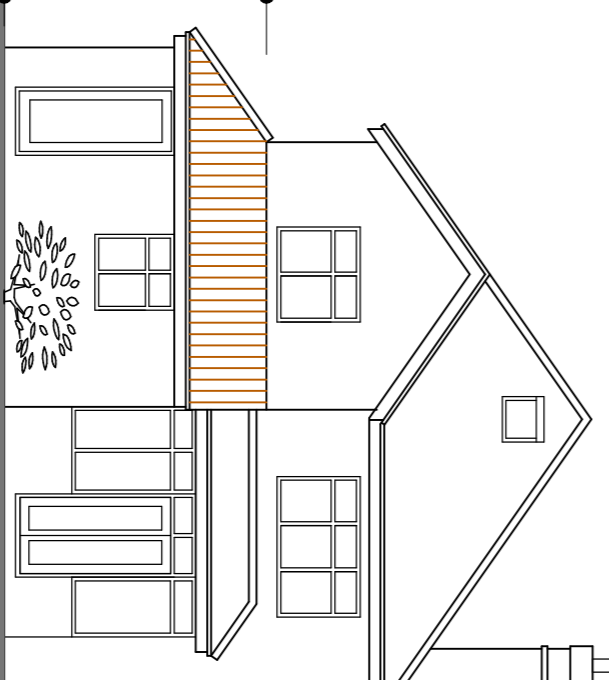

Proposed Rear Elevation

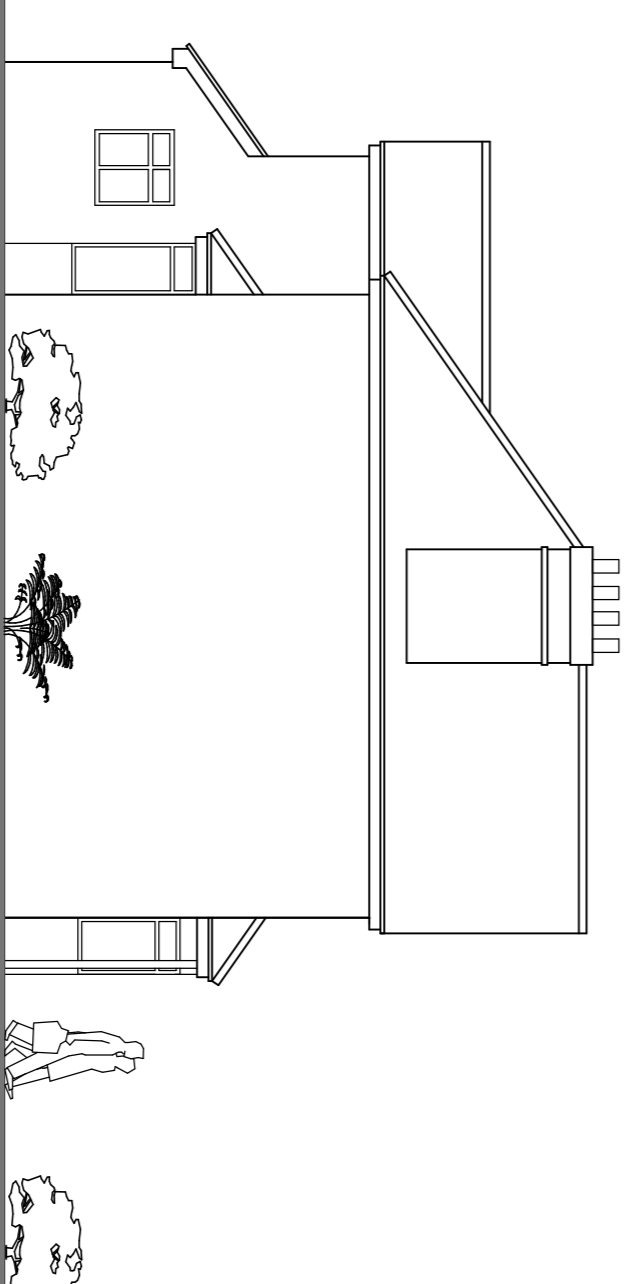

Proposed Side Elevation

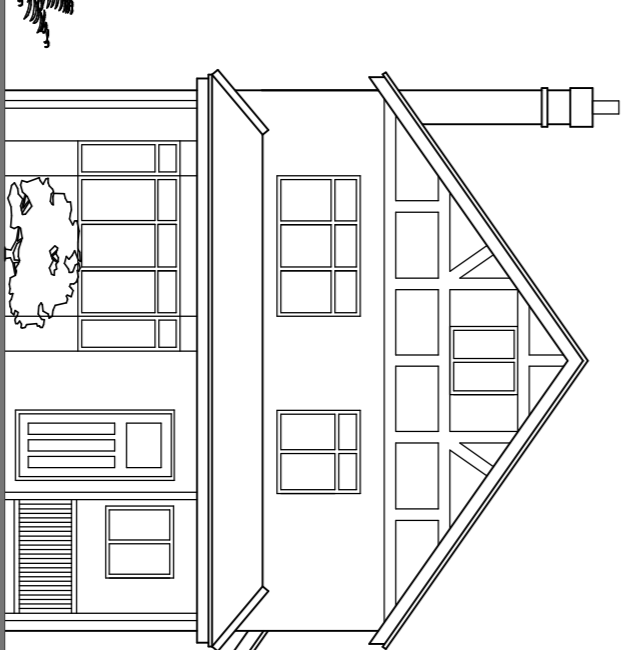

Existing Front Elevation

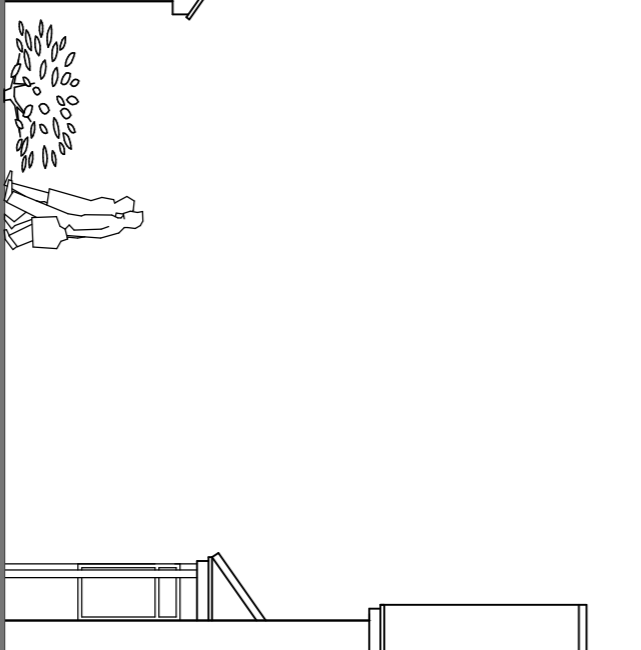

Existing Side Elevation

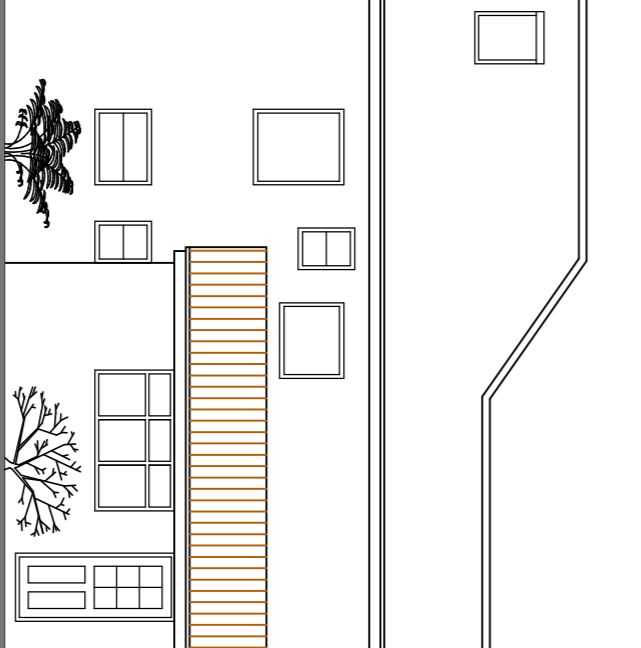

Existing Rear Elevation

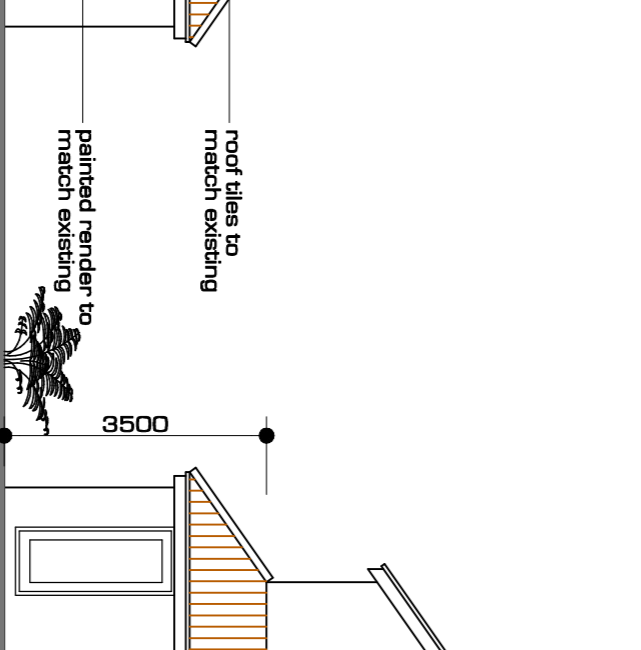

Existing Side Elevation

Rev Description

Date



HOWARD BUILDINGS,
69-71, BURHAM LANE,
GUILDFORD,
SURREY
GU4 7LX

Tel : 01483 457922
www.asaparchitectural.co.uk

Project 2, TEMPLE ROAD,
ERSOM,
SURREY

Client MR & MRS J. CHANDLER

Drawing PLANS & ELEVATIONS

Drawing No TRF/100/01

Date May 2021 Scales 1:50, 1:100, 1:500, 1:1250 @ A1