

**TYPICAL MULLION CASEMENT
ISOMETRIC DRAWING
NTS**

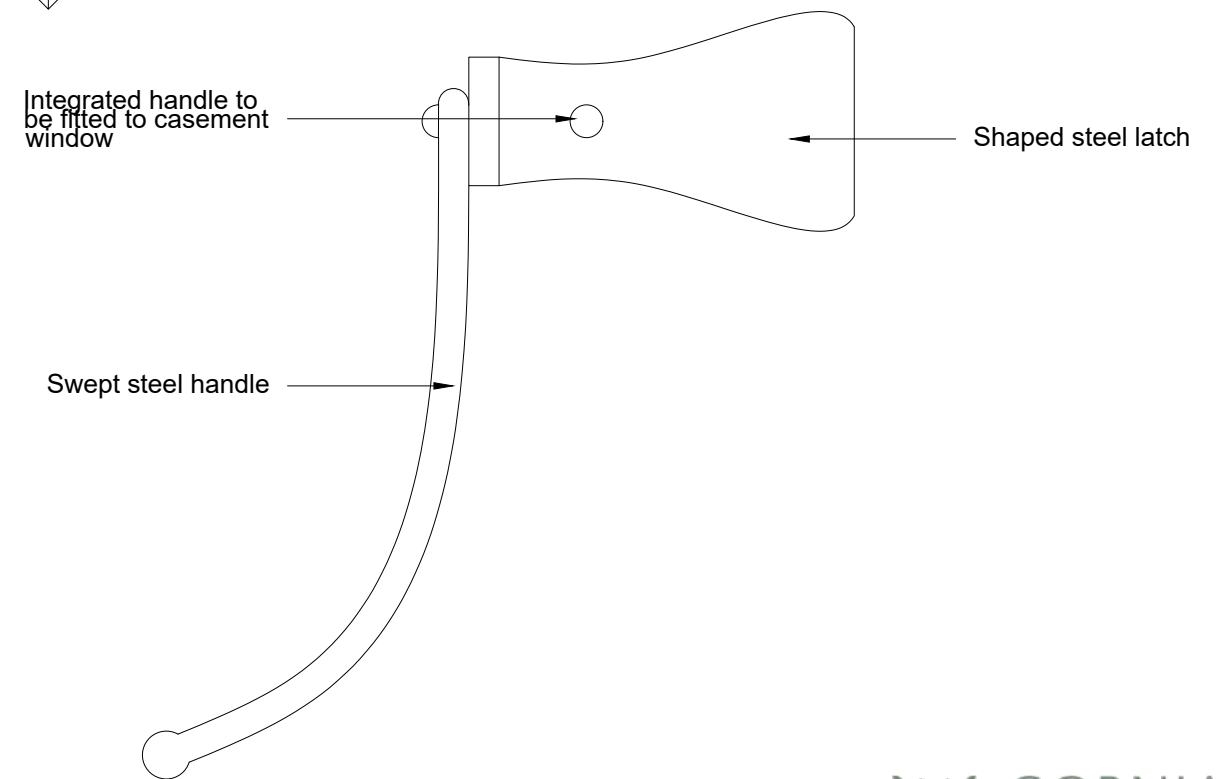
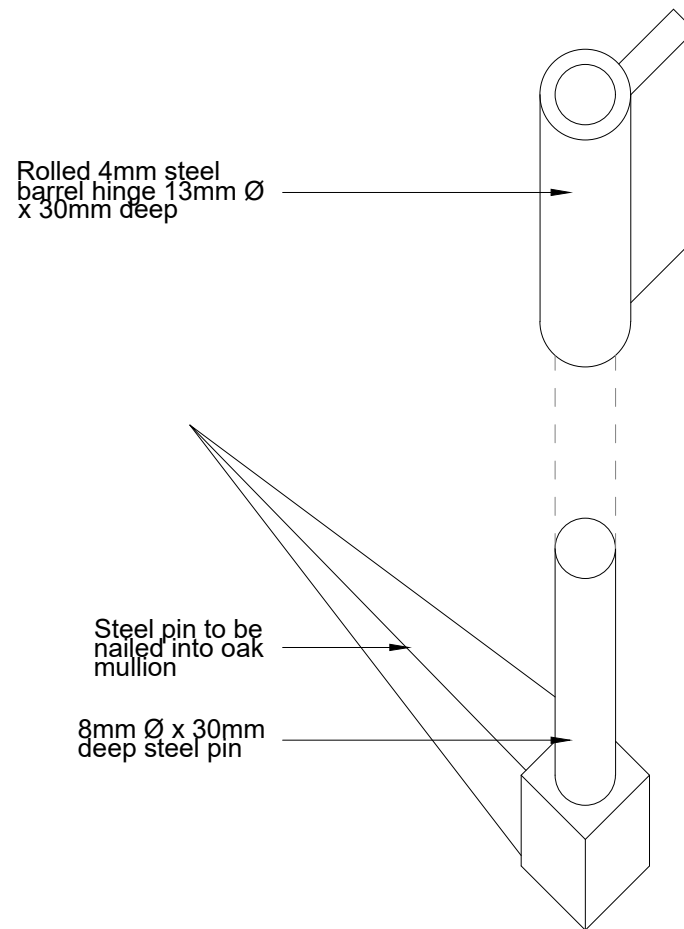

**IRONMONGERY DETAILS
1:1**

Notes:

Take site dimensions prior to manufacture

Cockspur handles and casement stays to be handmade by David Butler blacksmith.

Tel: 01379 640182

E-mail: david@countryforge.co.uk

Purpose made softwood windows with hardwood cills complete with check grooves and weather seals, allow for clearance.

Glazing to be 12mm slim-line double glazing units U-Value 1.6w/m²k fixed in place with appropriate putty.



ARCHITECTS • DESIGNERS

The Studio, 37 Church Street, Eye
IP23 7BD

01728 860 830
gmtld@gorniakandmckechnie.co.uk
www.gorniakandmckechnie.com

Drawn by SCJ Checked by TMcK	Scales @ A3 1:10	Project Threeways, Great Wenham, Suffolk, CO7 6QE	Drawing Title Opening Casement Details	Client Mr. & Mrs. Gould	Issue date 02/06/21	Project No 1845	Drawing No 411	Rev A
---------------------------------------	---------------------	---	--	----------------------------	------------------------	--------------------	-------------------	----------