



9000 Sliding Gates

Part of the

9000 SLIDING GATE RANGE

DESCRIPTION



PLUG & PLAY
INSTALLATION

Automatic | Compliant | Plug & Play

- 100% duty cycle heavy industrial usage
- BS EN 12453 Peace of mind for safety
- Single Phase Supply
- Plug & Play installation
- Programmable control panel c/w fault diagnostic on screen display
- Highest specification of components are ONLY used
- Seamlessly forms part of the existing fence lines perimeter security
- Aluminium construction for long lasting and maintenance free performance
- MANY different infill's available to match clients exacting requirements
- Error log is stored in the control panel for fault diagnosis
- A VERY easy to use manual release mechanism which requires no tools in the event of power failure.

9000 ADDED BENEFITS

- Ease of installation
- Low maintenance
- 99.9% Access Control compat
- Pedestrian input as standard
- Fire Alarm Input pre-configured
- Designed and built to last
- Easy to use for end users

OPTIONAL EXTRAS

- Razor Wire Extensions
- Electric Fence
- Anti-Climb Spikes
- Traffic Lights
- Warning Siren
- Timber Infills
- Louvre Infills

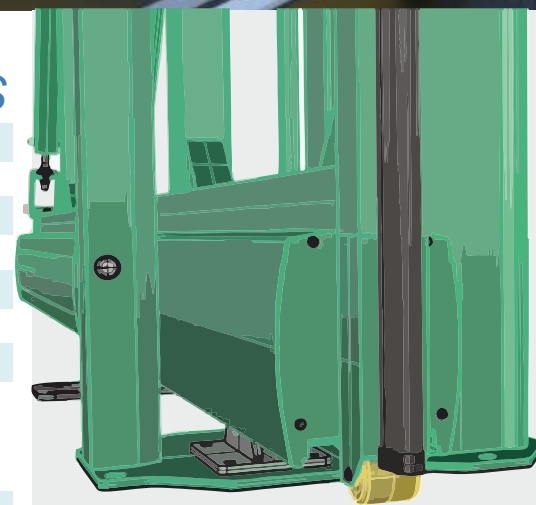

"INDUSTRY STANDARD"

Our gates have been classed as the best in the industry. It has been designed to last using the best materials and components that we can buy. As with all our products they are 100% Duty Cycle



ABSOLUTE CONTROL

The 9000 Sliding Gates feature a Feig control panel that is far more advanced for safety and motion than its rivals

**THE UK'S
No1
TRIED,
TESTED
& TRUSTED
INDUSTRIAL
GATES**

The 9000A Automatic Cantilever Sliding Gate complies with BS/EN 12453. The gate portal is fitted with dual height photocells and 6 category 3 monitored live safety edges. The gate is controlled by a purpose made German Feig control panel, single phase supply, via an integrated frequency converter controlled output to a 3 phase motor. This can be configured very easily for all the standard program modes including no passage time outs & free exit and entry loops to name a few. As standard the control panel can accommodate pedestrian open signals, airlock systems and much more. The gate's movement is controlled via a rack & pinion system monitored by an encoder. This allows for a precise and controlled operation that is robust and dependable. Our gates are delivered on a vehicle equipped with a crane, fully assembled, ready to bolt down continuing our "plug & play" ethos. This minimises disruption on site and ensures a smooth, quick and easy installation. We have developed the gate using aluminum construction with its obvious anti-corrosion properties/strength and longevity in mind. Trusted by many in the industry as the ultimate sliding gate it can be clad with a HUGE range of infills to suit the existing perimeter fence line.



Sampson & Partners Fencing, Redwell Wood Farm, Ridge Hill, Potters Bar, Hertfordshire, EN6 3NA Tel: 01707 663400



9000 Sliding Gates



PRODUCT SPECIFICATION

Gate Speed

3 to 6 Seconds Per Metre
(Speed WILL vary dependant upon gate size/Infill etc)

Duty Cycle

100% Heavy Industrial Usage
Suitable for Indoor & Outdoor Usage

Specification

CE Approved, TUV Approved

Power Requirements

Single Phase 240v 50Hz 10 Amps

Colours

All RAL Colours Available
(Non Standard RAL's Optional Cost)

Maximum Span Dimensions

12m Clear Drive Through Opening

Maximum Height Dimensions

2.4 Metres (Max Width 12m)

3.0 Metres (Max Width 10m)

Material Construction

Aluminium Construction of Gate Leaf and Main Tower
Tower Top/Base plate Wheel Carriages Zinc Plated Steel

Unit Weight

560Kg Approx
(dependant upon gates size and infill type)

CAD Drawings provided as standard

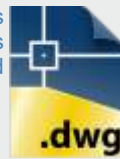

Tech Support provided and FREE mobile APP as standard



PLUG & PLAY INSTALLATION

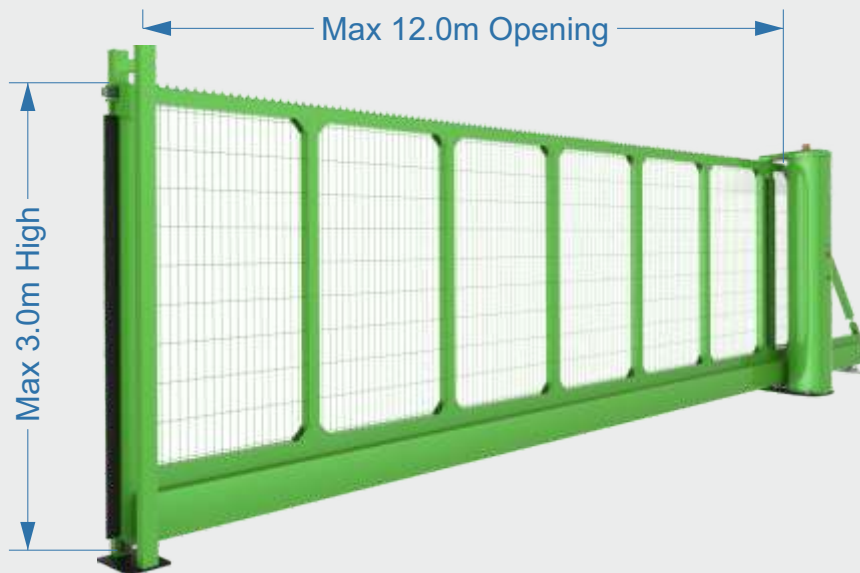

*All gates are bespoke and manufactured to order.



MANUAL POSITION
Holding the lever upwards releases the roller from the beam for manual use.

Easy to Use Manual Release

LEVER UP

Strong Lower Beam Design

Six Category 3 Safety Edges

Advanced Rolling Gear

