

Ground Floor Plan Scale 1/50 at A3

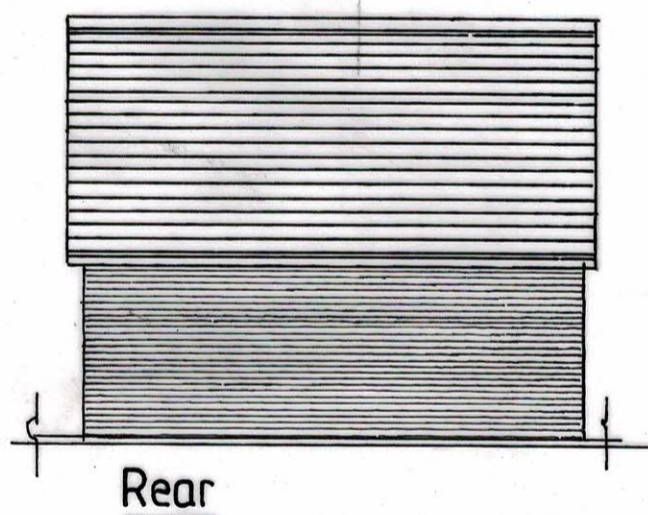

Proposed Elevations
Scale 1/100 at A3

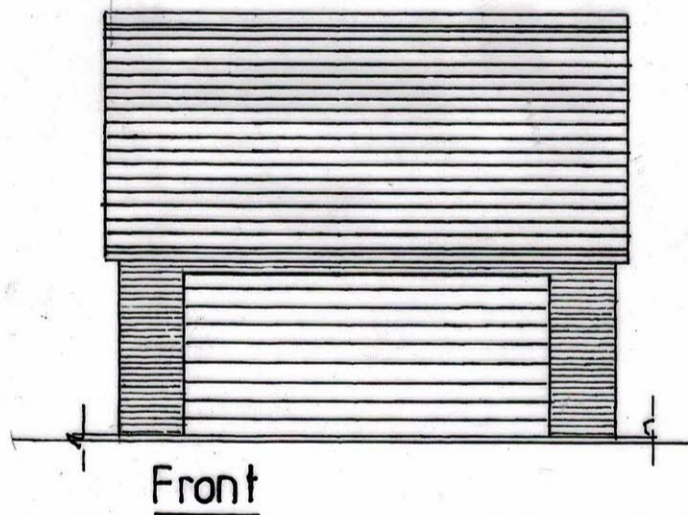
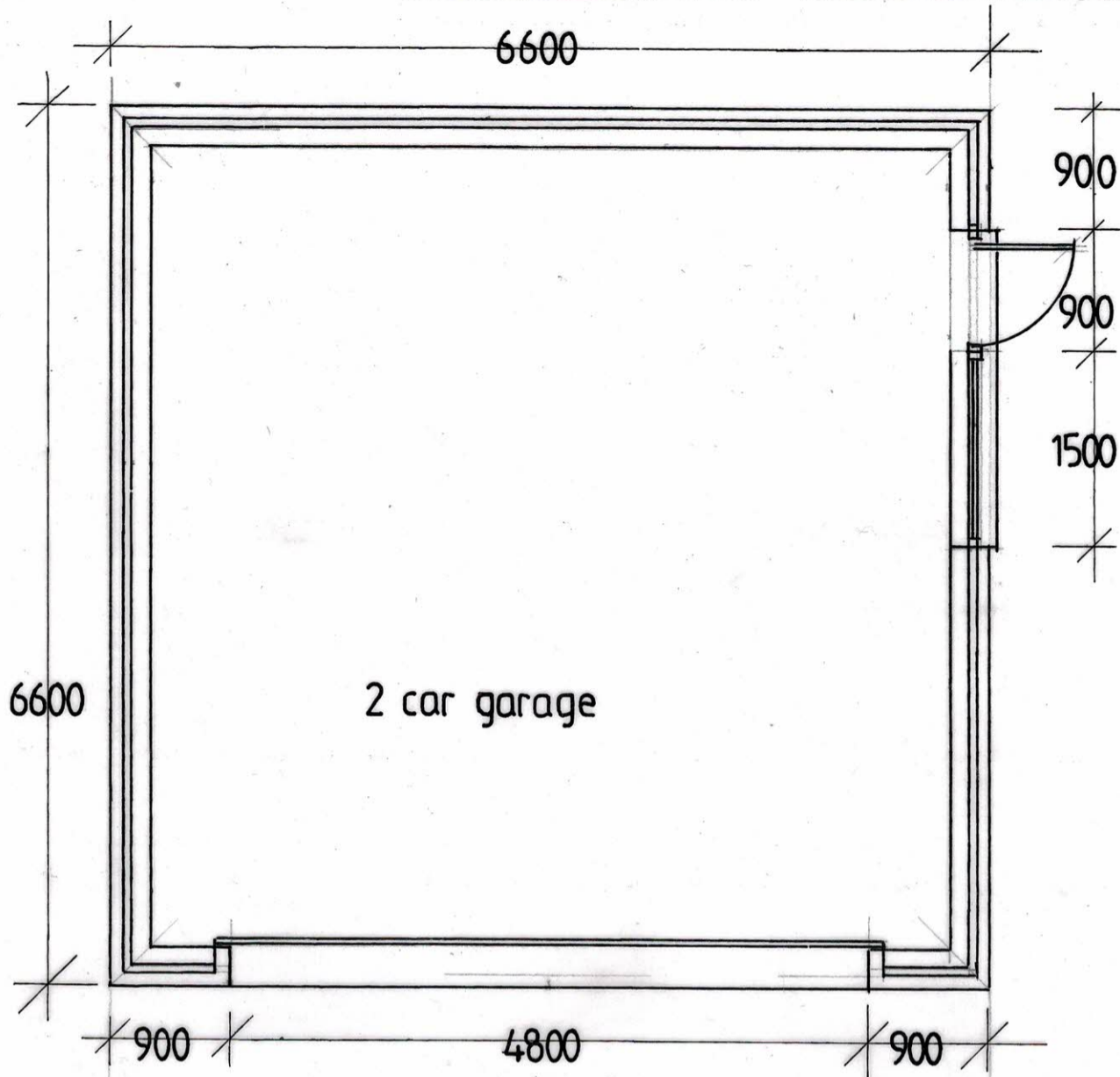
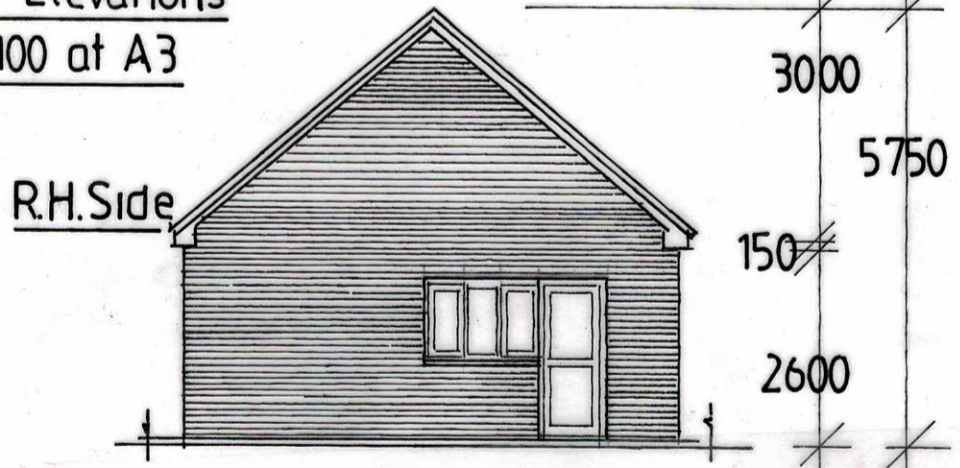
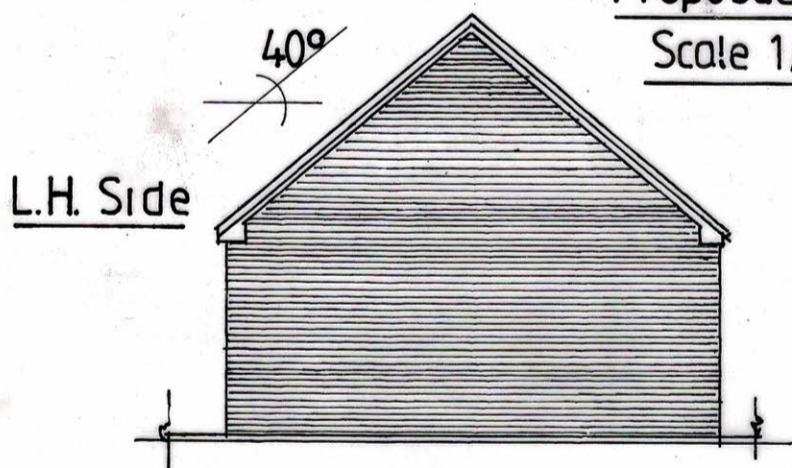

PROJECT:- New Detached Dwelling & Garage
 LOCATION:- Plot 2, Land to the North of Heol Uchaf, Rhymney, NP22 5DN
 CLIENT:- Mr. J. Slater
 DWG .NO.:- PL 01/4
 DATE ; May 2021
 SCALE 1/ 100 ; 1/50 at A3

Drawn By:- *David I. Jones,*
 Building Design Services
 8, Birchgrove,
 New Tredegar
 Tel: 01443 820306
 davidijonesbuildingdesign@hotmail.co.uk