

Genesis *V/S*

Vertical Slider

**Vertical Slider
Section Detail**
for
**Genesis Mechanically Jointed &
Genesis Graf Welded
Vertical Sliders**

PRODUCT GUIDE

Main & Bead Profiles

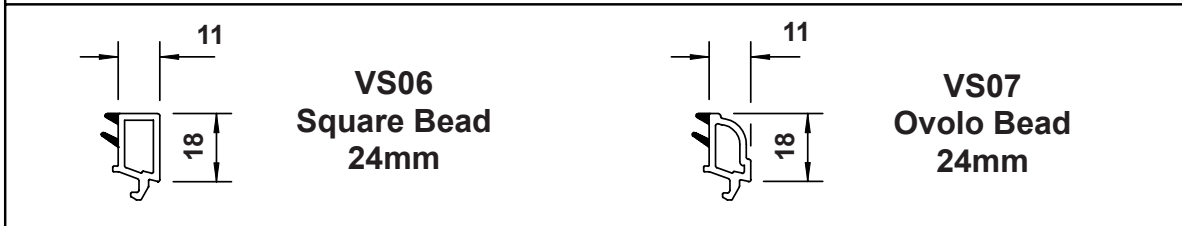
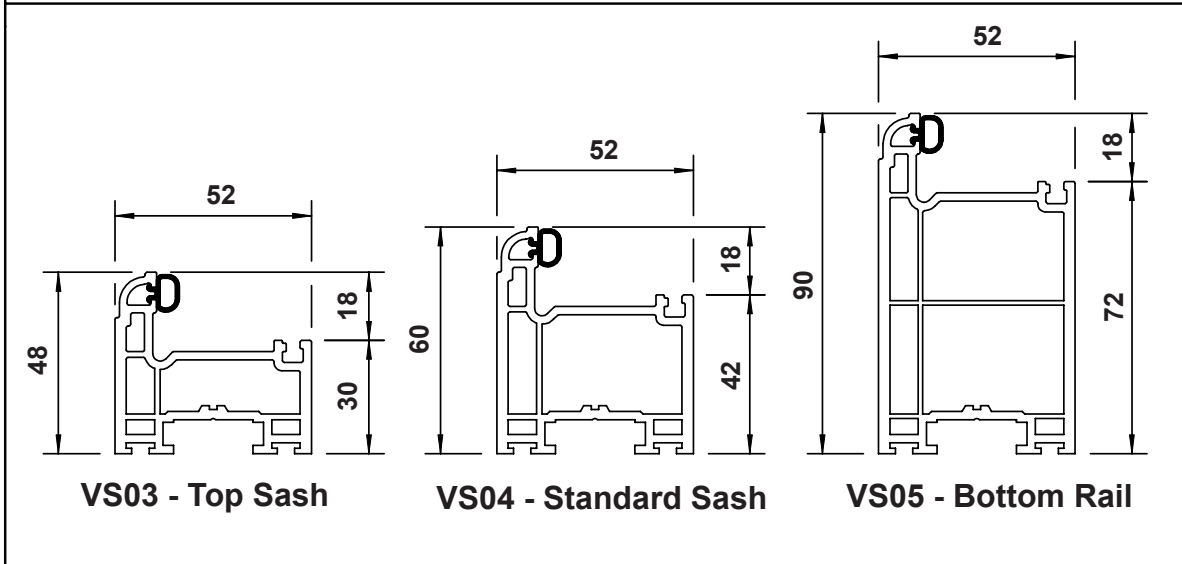
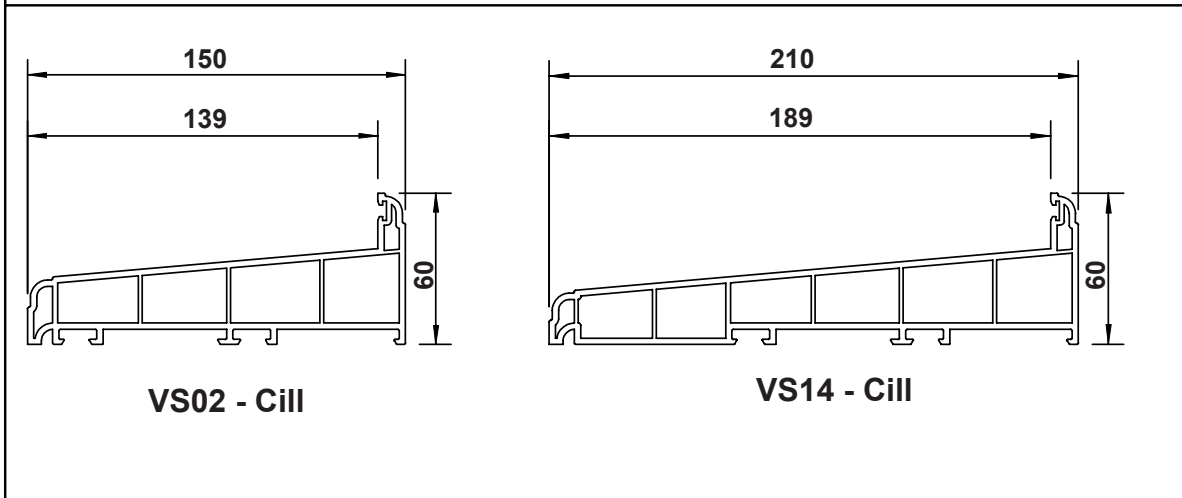
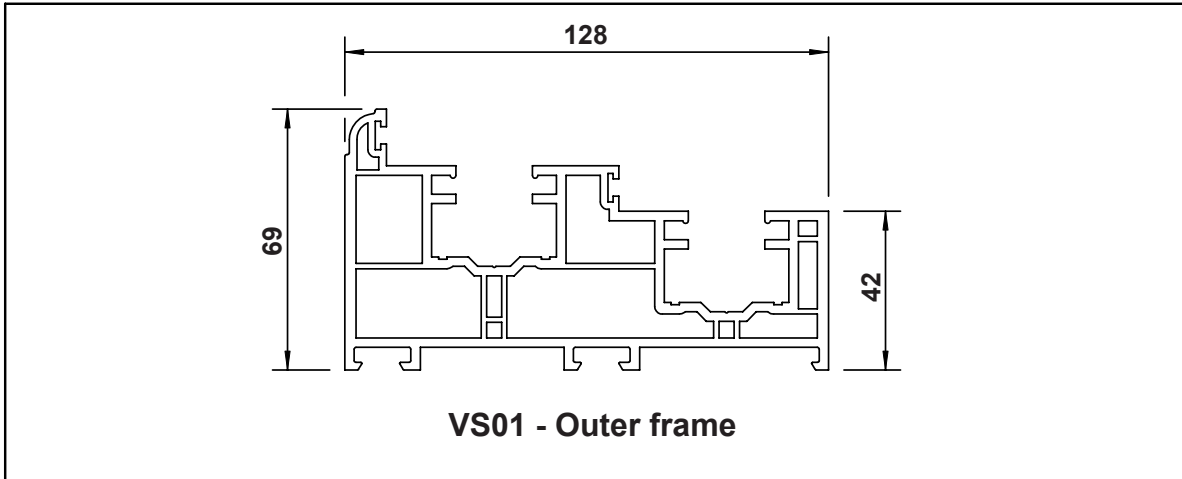

PRODUCT GUIDE

Ancillary & Reinforcement Profiles

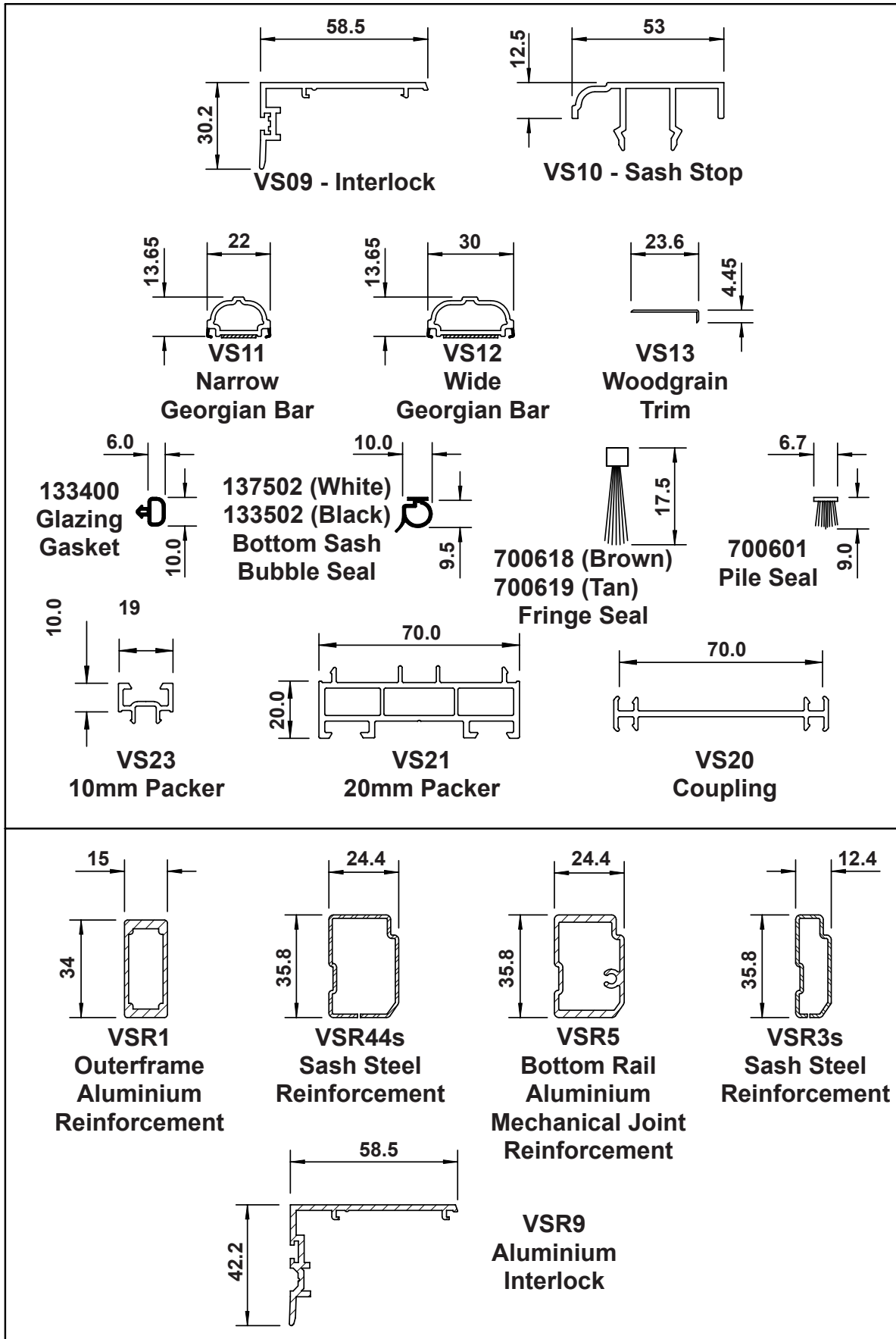

WEATHER BAR

Assembly

1. End prep the cill using the VSJ02 drill jig.
2. When using the VS08 weather bar, we would recommend the use of a gasket to seal the joint between frame and cill. They are available from:

RGH Rubber
Tel: 01371 875 941
Part Number: Pn 0703

3. Fix the joint using 4no. 5mm x 60mm countersunk PVC screws.

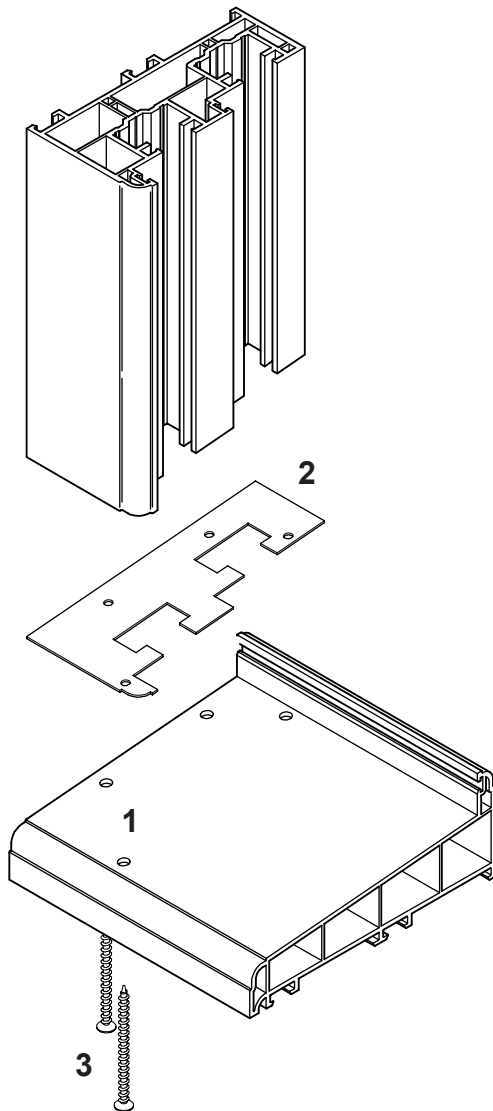

4. To allow drainage, ensure that the woolpile at the bottom of the outer frame, is prepped as shown below.

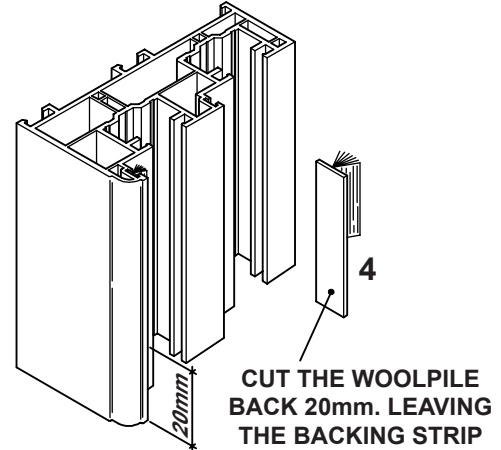

5. Drill through the top wall of the cill using the VSJ08 drill jig. Maximum of 150mm from each jamb and no more than 300mm centres.

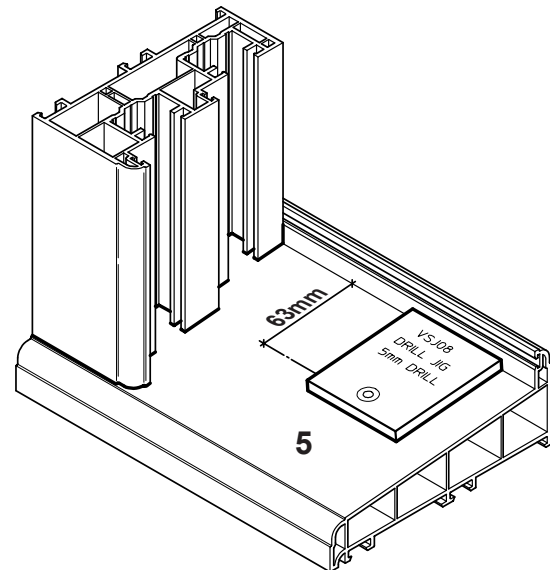

6. Insert the BM15 fixing studs into the cill.

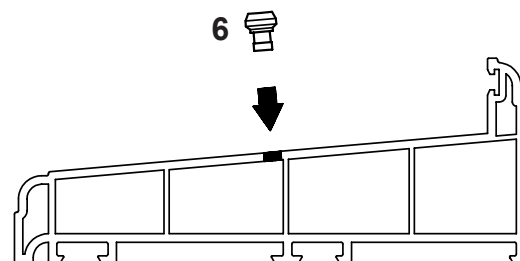

WEATHER BAR

7. Cut the VS08 weather bar, cutting size is finished outer frame size -109mm. Prep each end as shown below.

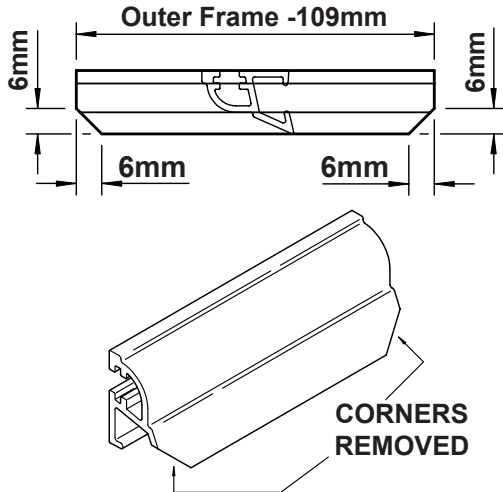

8. Cut drainage slots in the back as shown below, they should be positioned approx 300mm from each end and a maximum of 600mm centres. *Note: Ensure the slots do not clash with the BM15 fixing studs.*

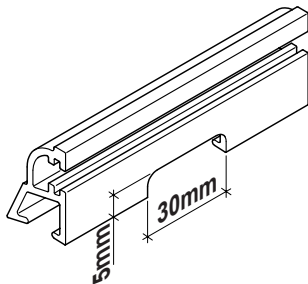

9. Insert woolpile, and clip the VS08 into position.

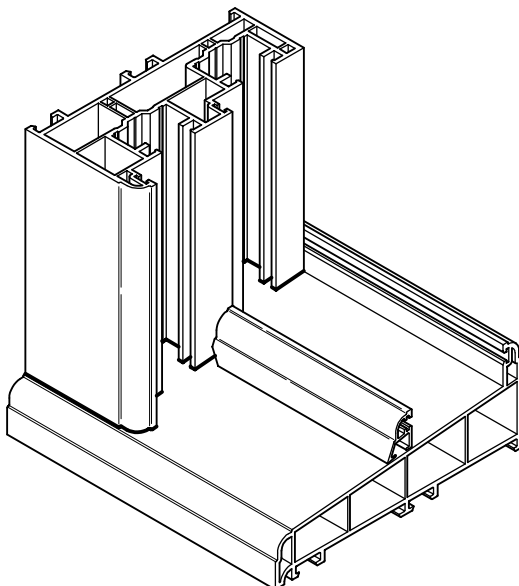

10. End prep the lower VS10 sash stops as shown below.

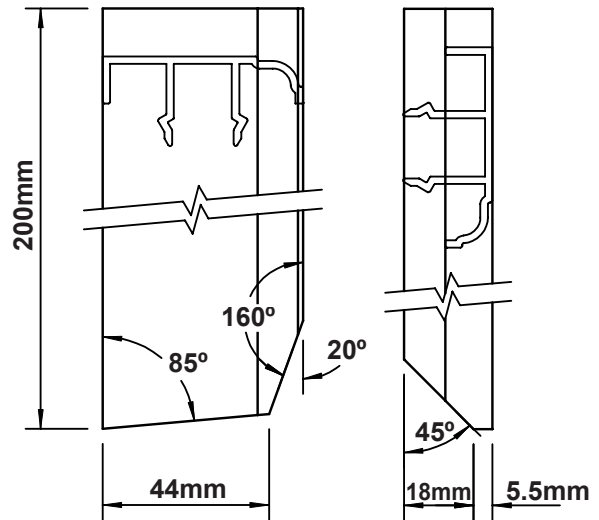

11. Clip the VS10 sash stops into position.

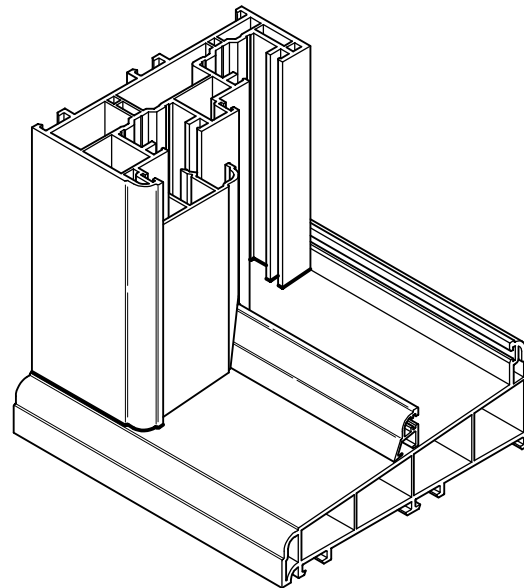

12. The 133502 & 137502 flexible bubble seals should not be used at the bottom of the lower sash. To aid fabrication, the woolpile can be used on all sides.

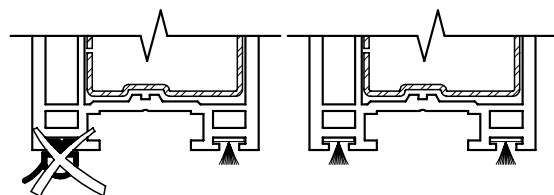

WEATHER BAR

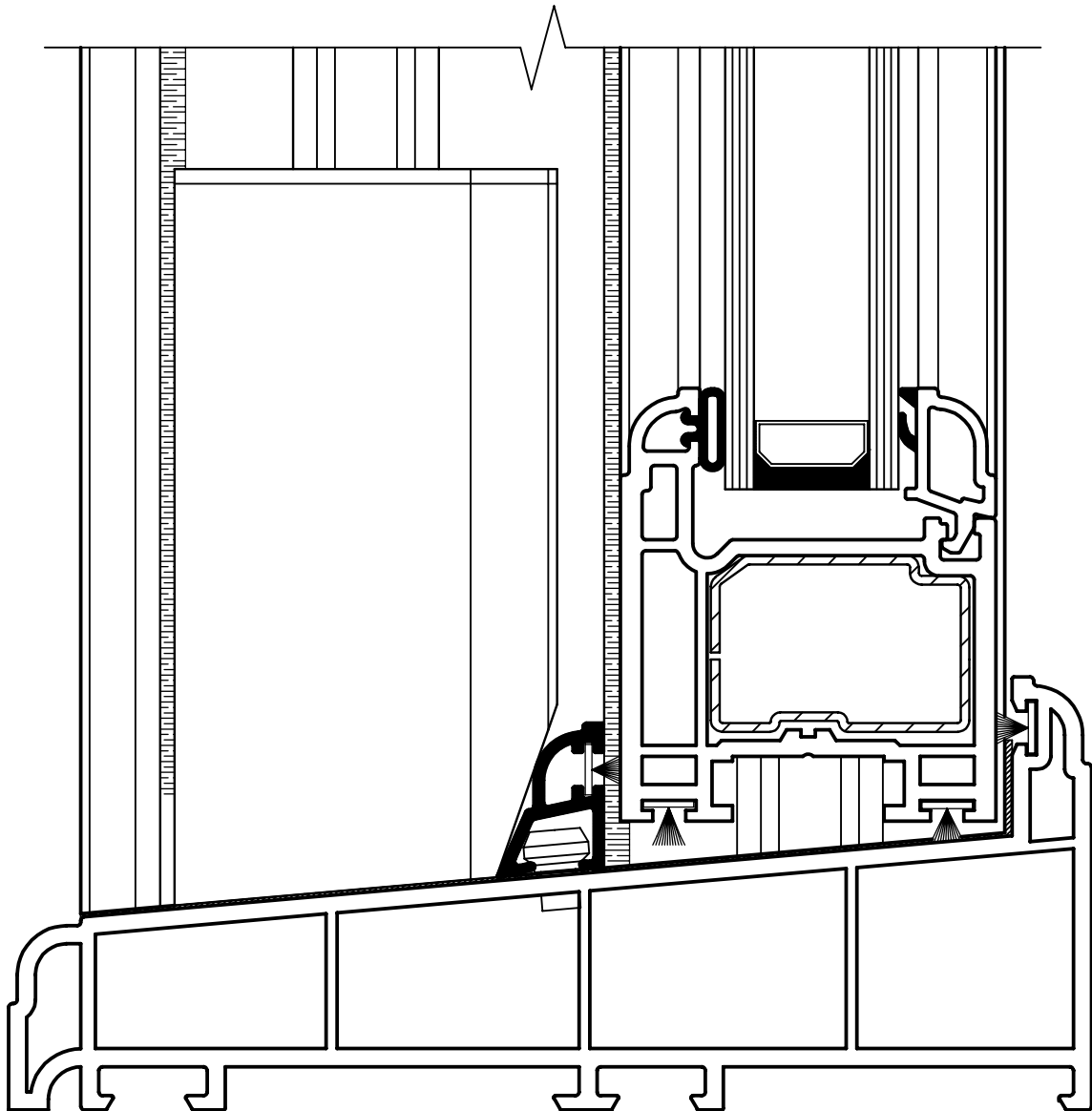

Optional Weather Bar

- Improves weathering.
- Enhances appearance.
- Can be retro fitted.

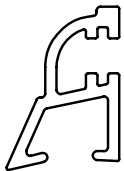

**VS08
WEATHER BAR**



**BM15
FIXING STUD**

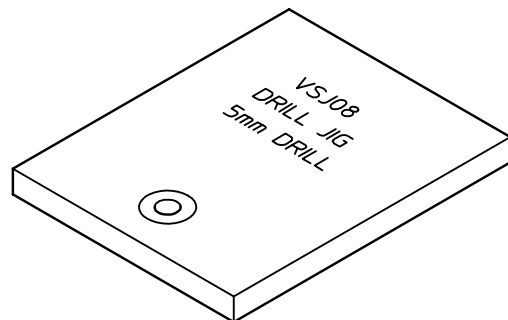

**VSJ08
DRILL JIG**

DETAIL SHEETS

Section Through Configuration

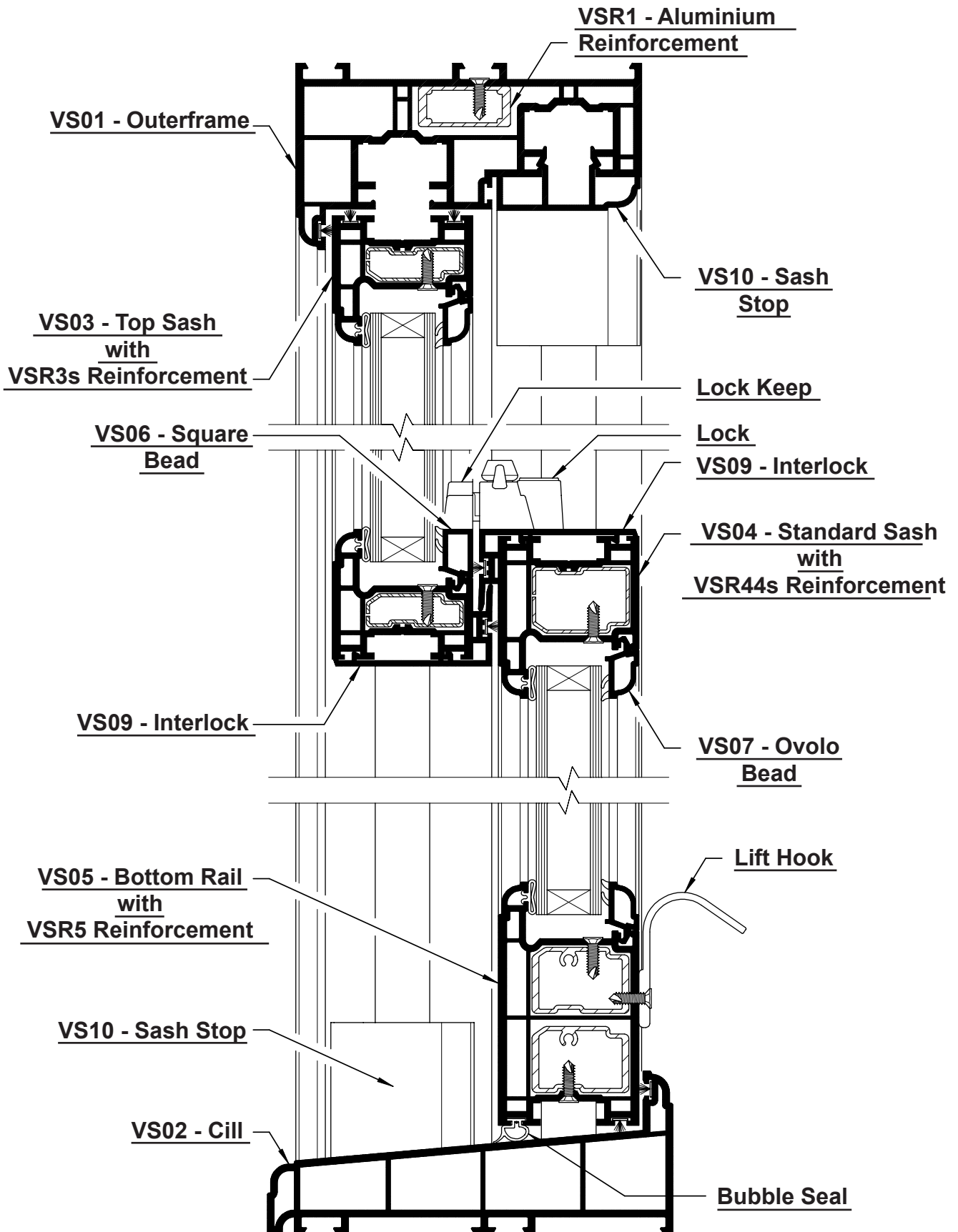

DETAIL SHEETS

Vertical Section - V1

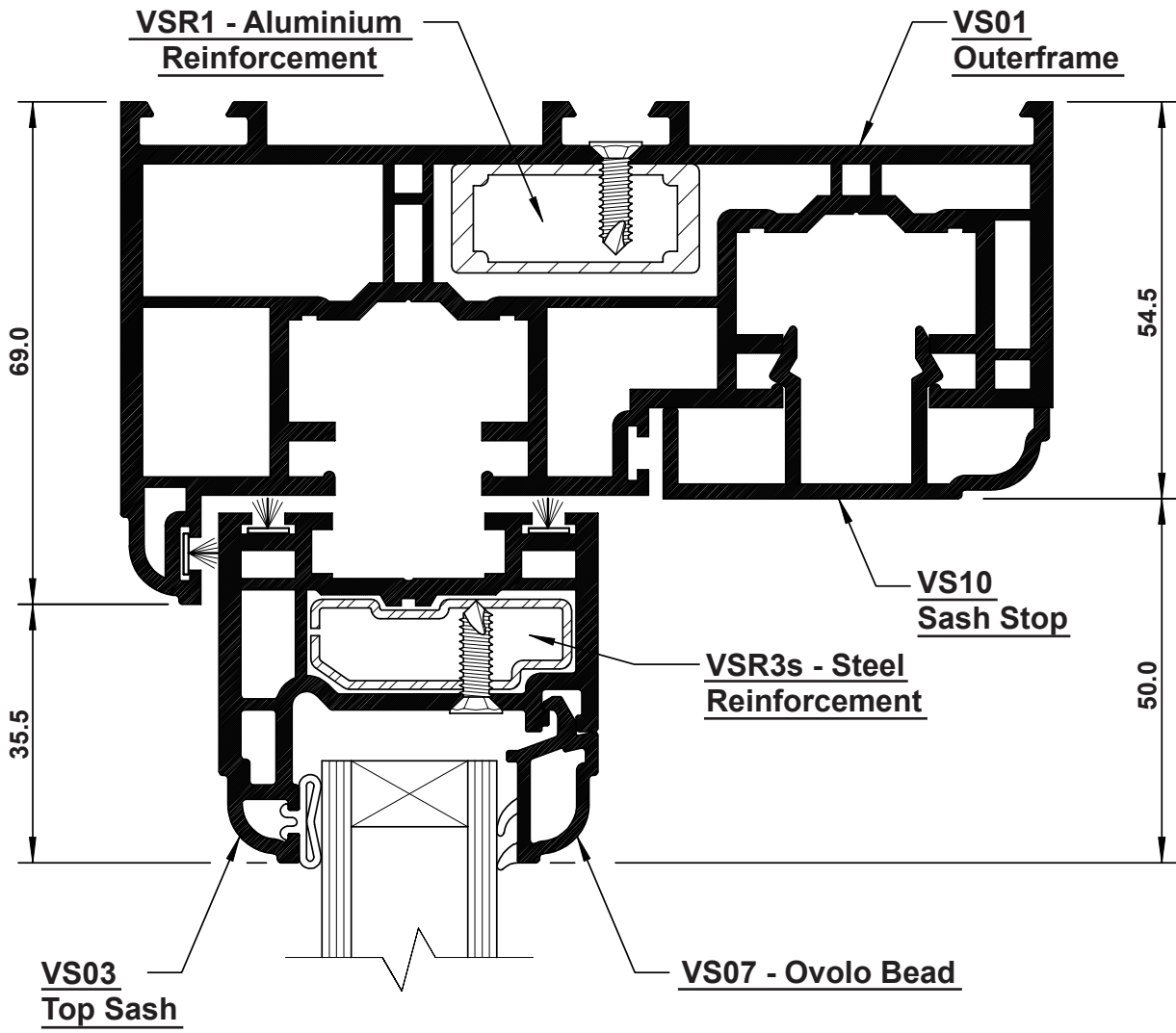

(window viewed from outside).

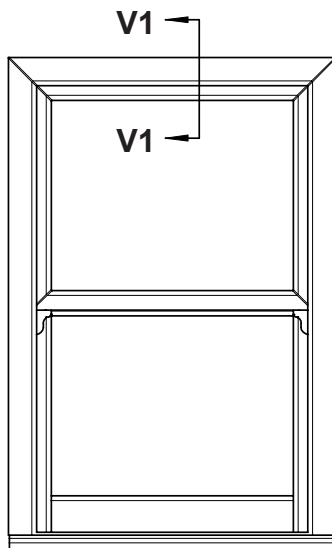

DETAIL SHEETS

Vertical Section - V2

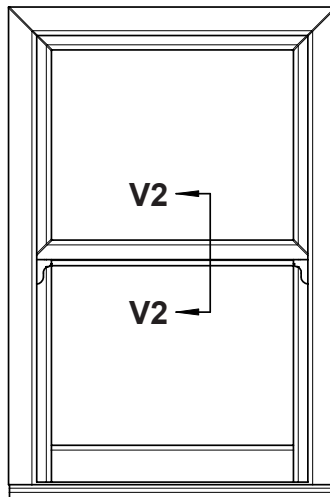
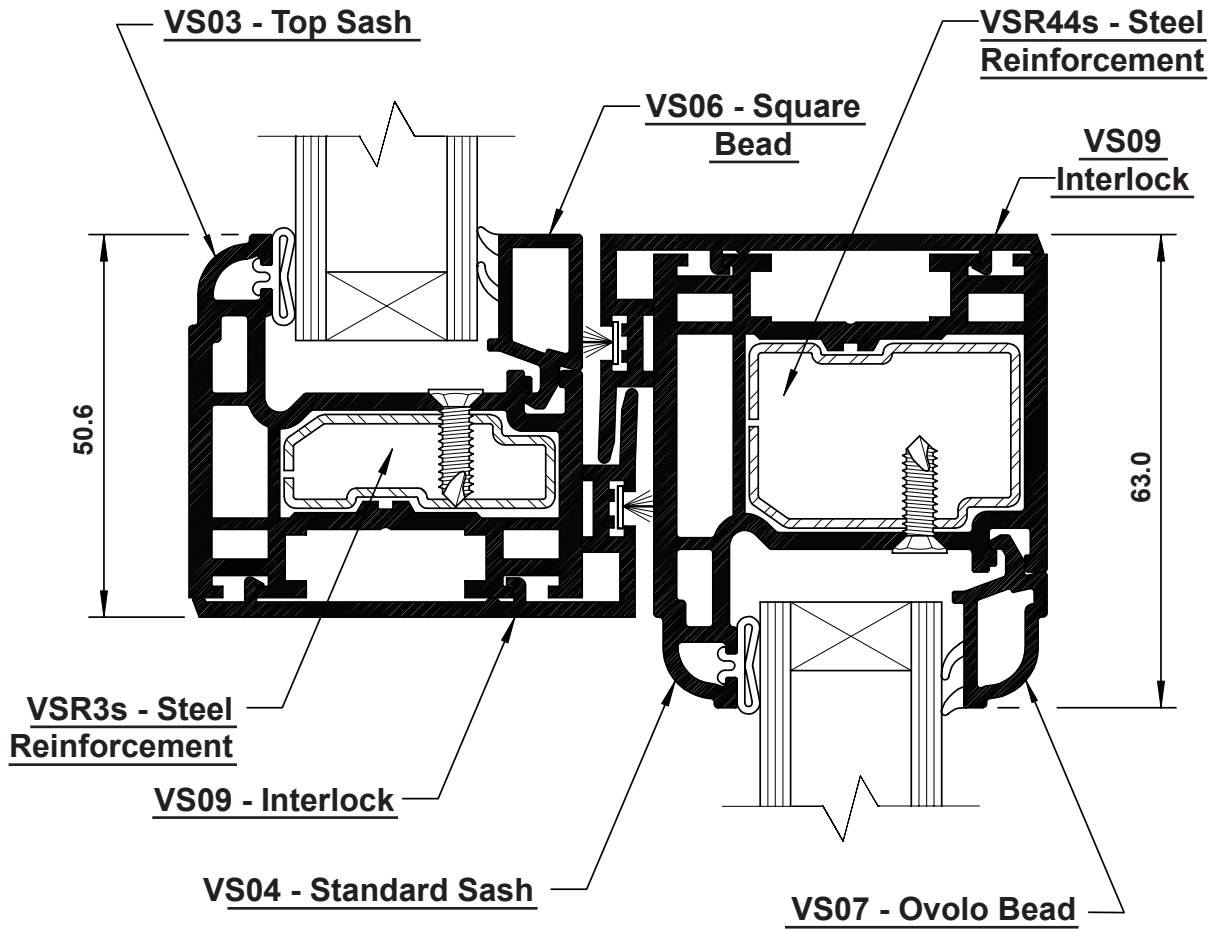

(window viewed from outside).

DETAIL SHEETS

Vertical Section - V3

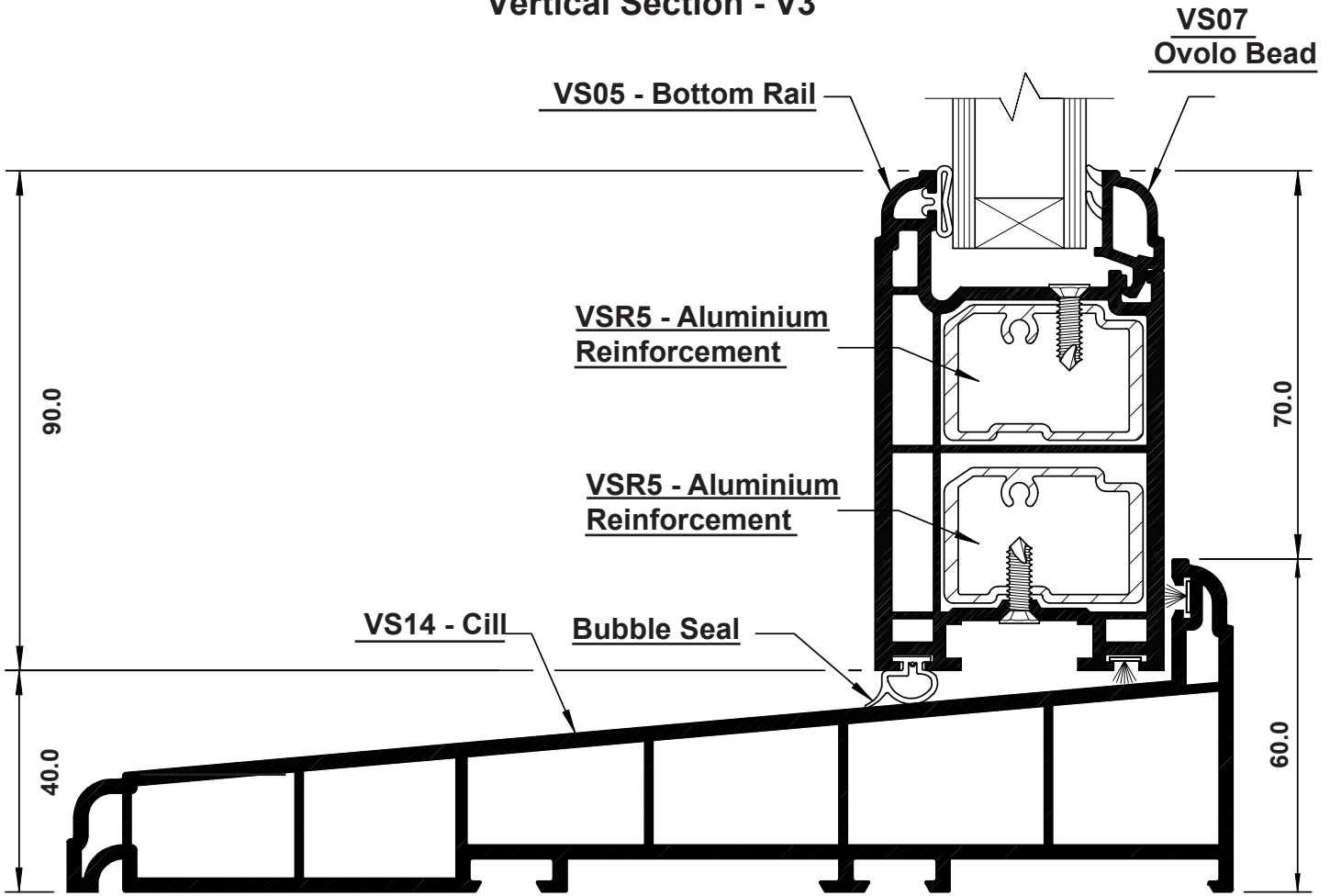

(window viewed from outside).

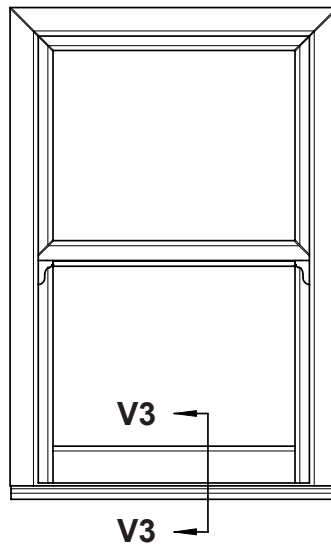

DETAIL SHEETS

Vertical Section - V3 (Without Deep Bottom Rail)

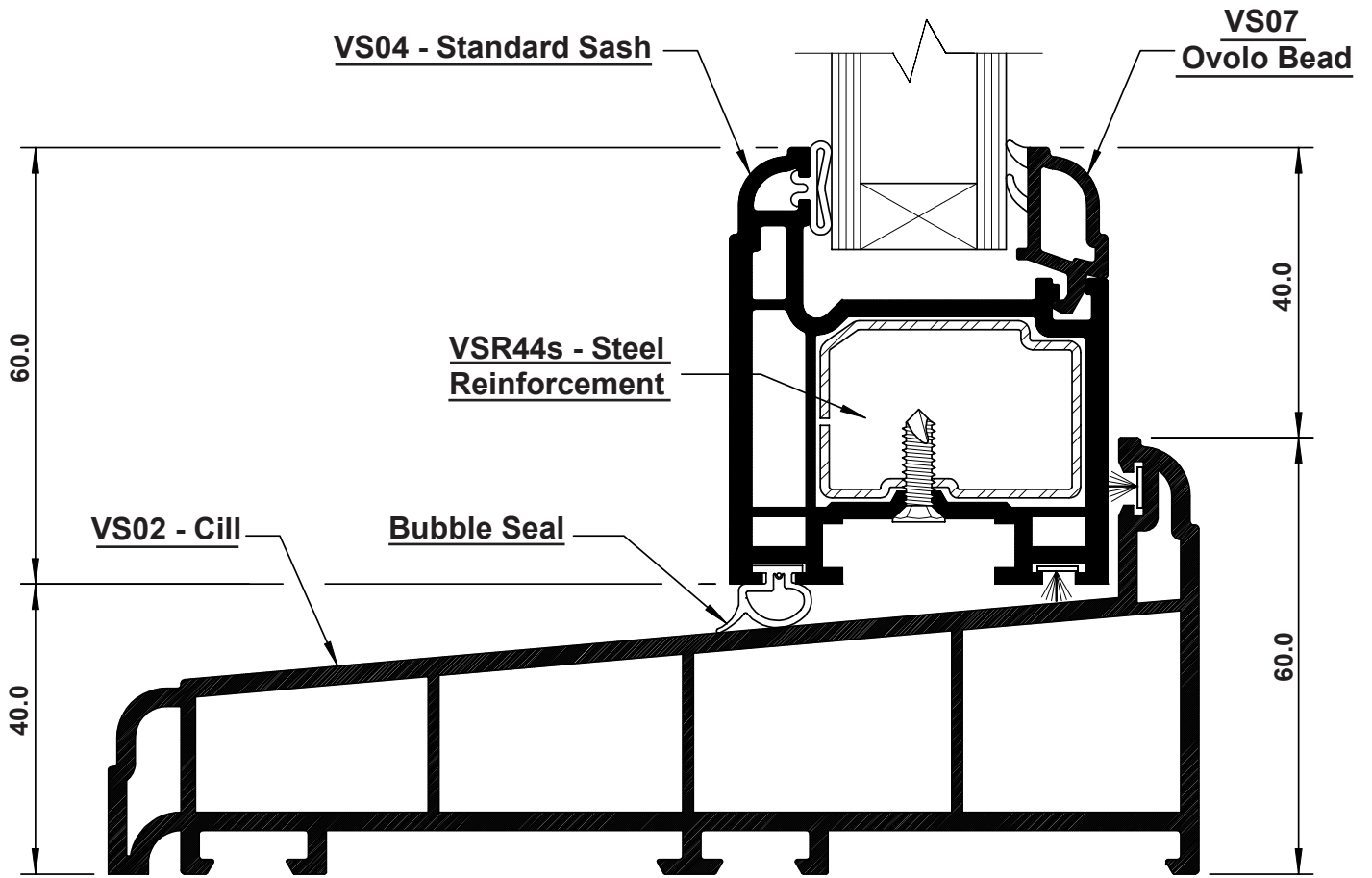

(window viewed from outside).

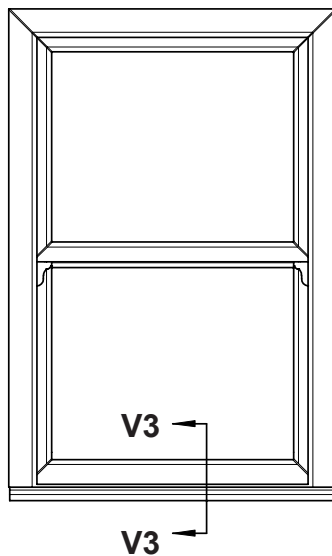

DETAIL SHEETS

Horizontal Section - H1

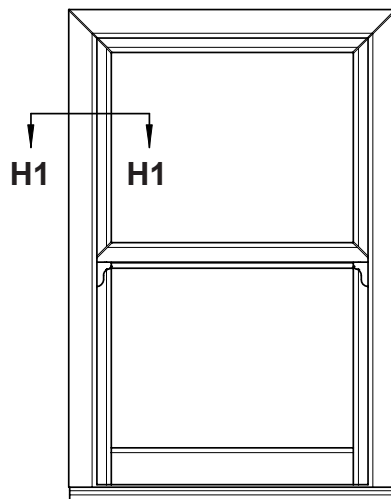
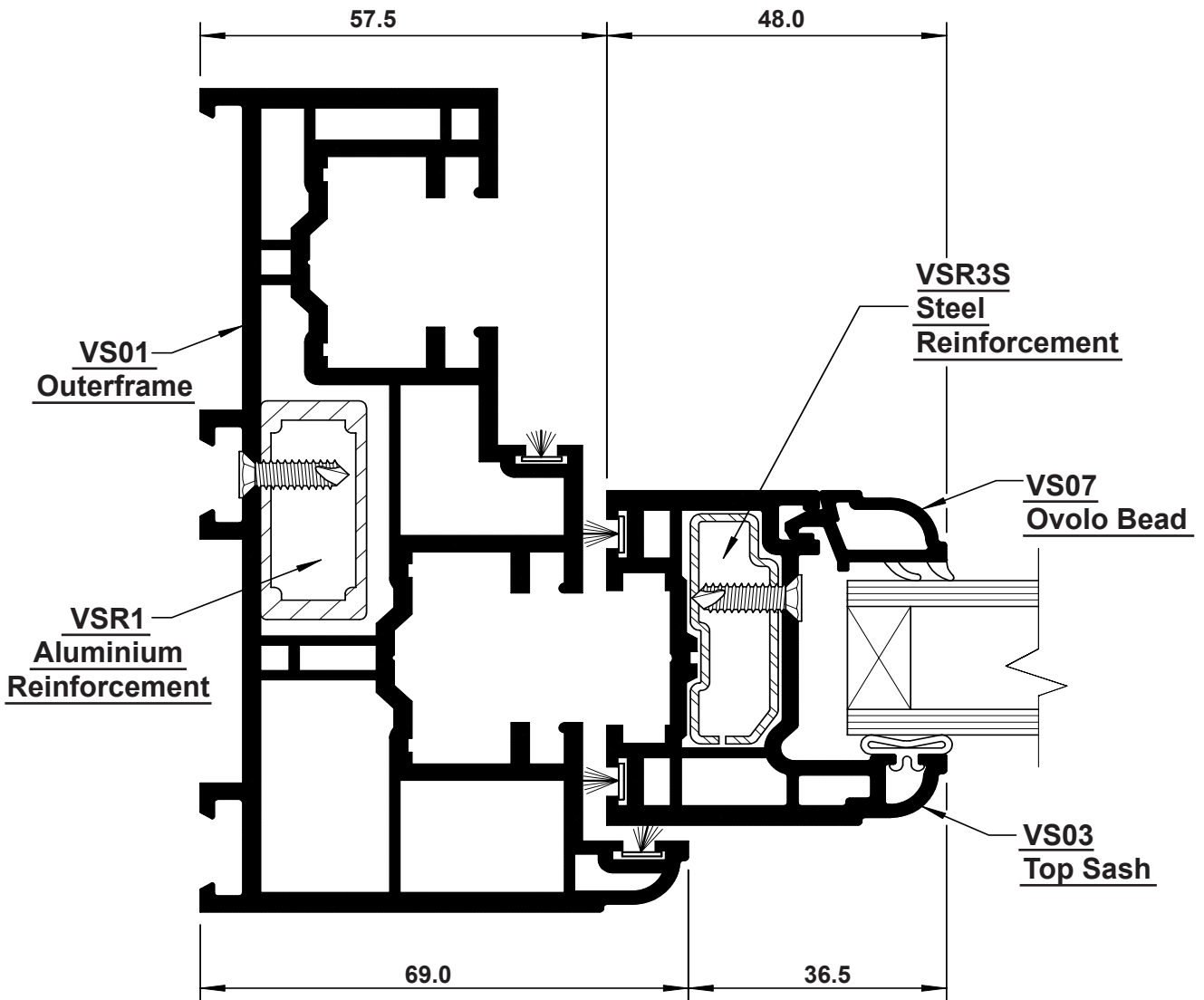

(window viewed
from outside).

DETAIL SHEETS

Horizontal Section - H2

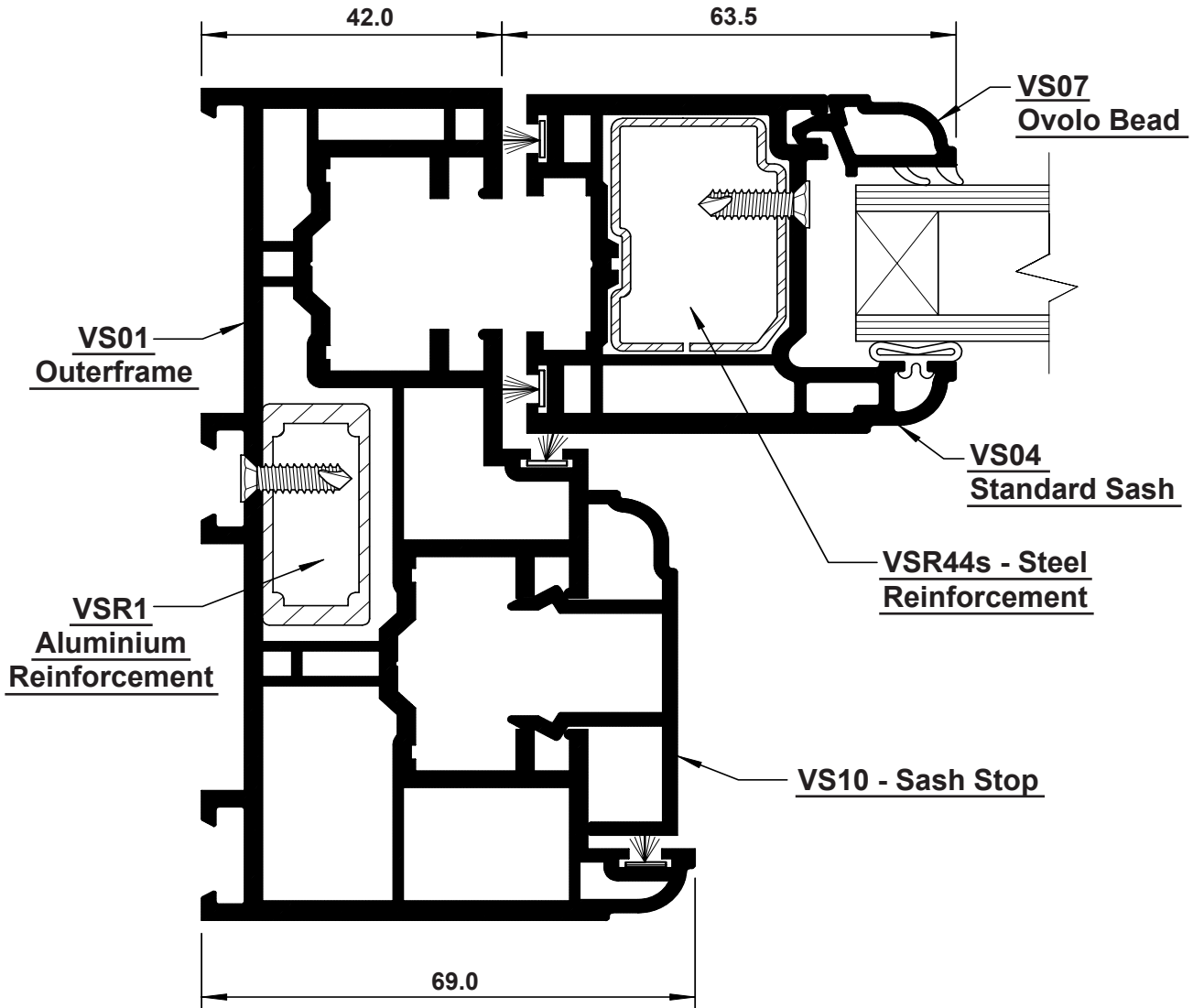

(window viewed
from outside).

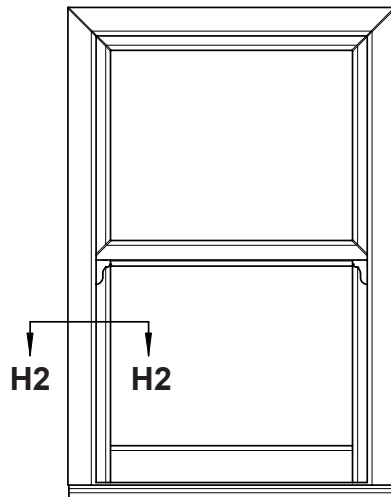

DETAIL SHEETS

Horizontal Section - H3

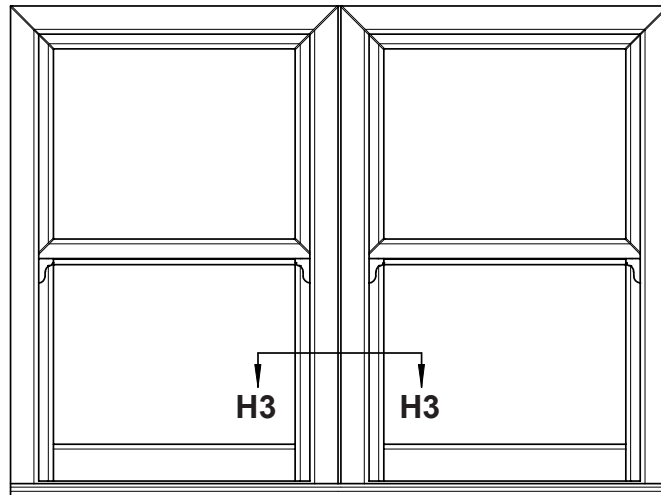
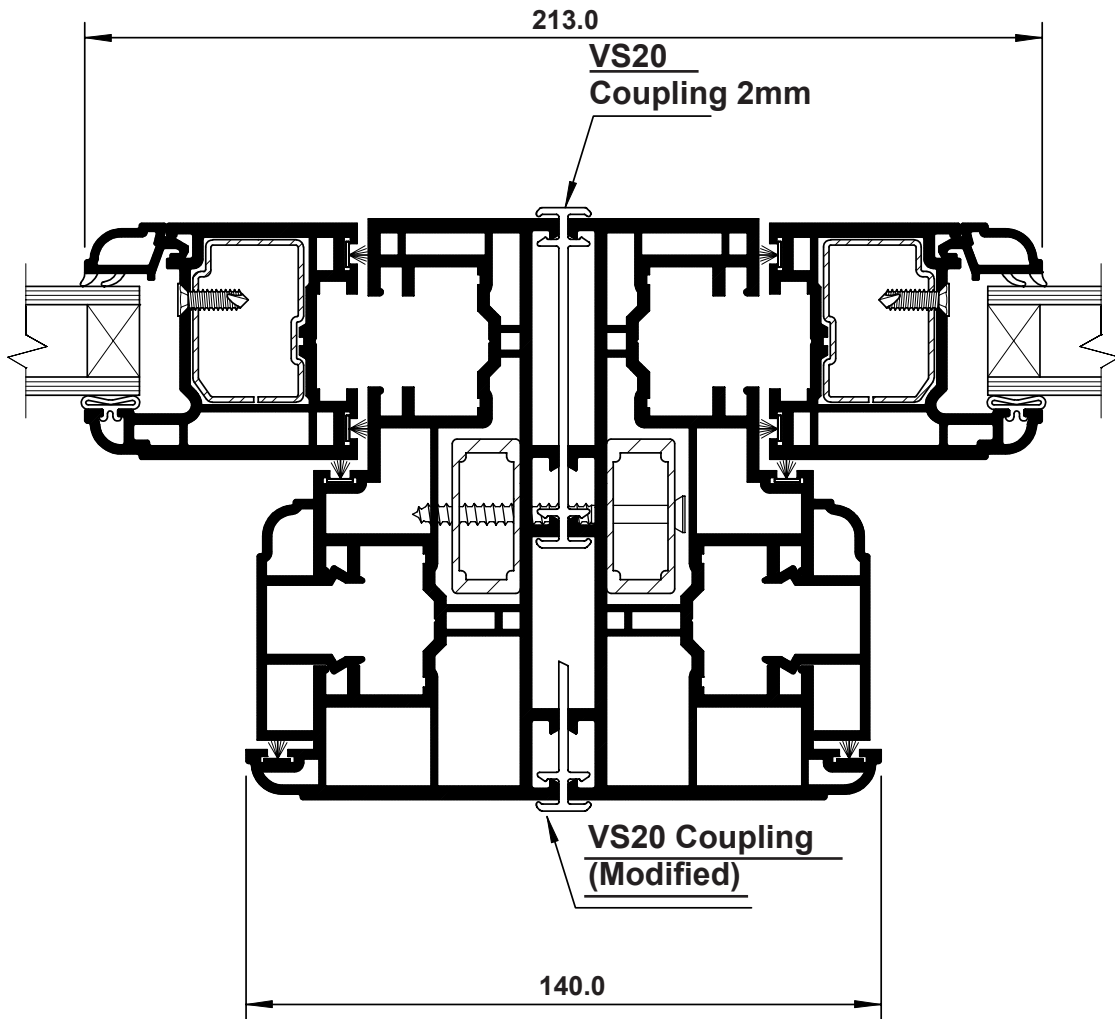

(window viewed from outside).

REINFORCEMENT

Reinforcement Location & Fixing Points

Reinforcement should be secured to the PVC-U profile at a maximum of 100mm from the ends of the reinforcement and then at a maximum of 400mm centres (300mm when using foiled profiles). The recommended screws are self drilling, M4 flat faceted head, TEKS point screws.

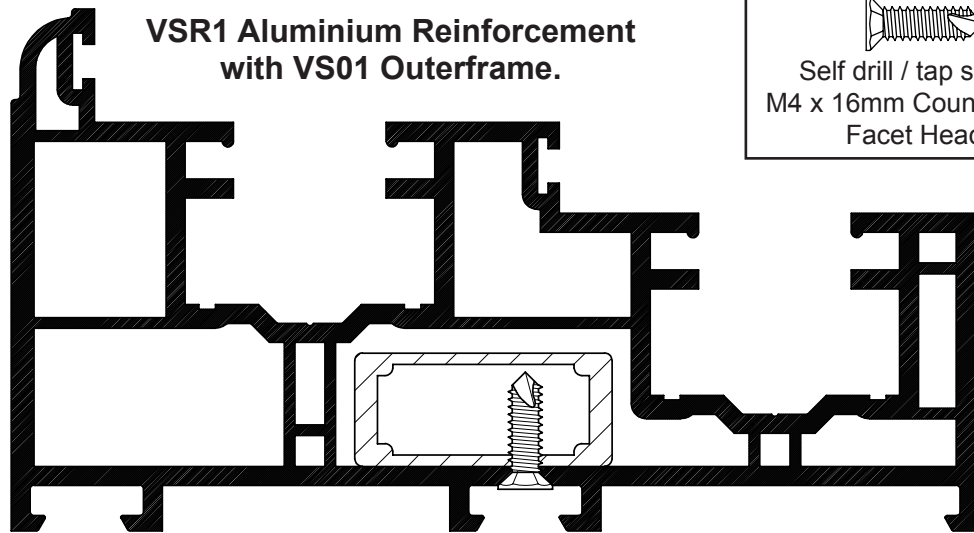

VSR1 Aluminium Reinforcement with VS01 Outerframe.

Self drill / tap screw
M4 x 16mm Countersunk
Facet Head

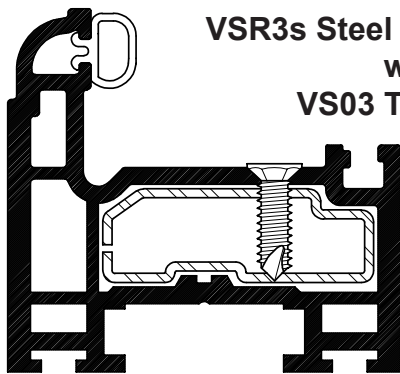

VSR3s Steel Reinforcement with VS03 Top Sash.

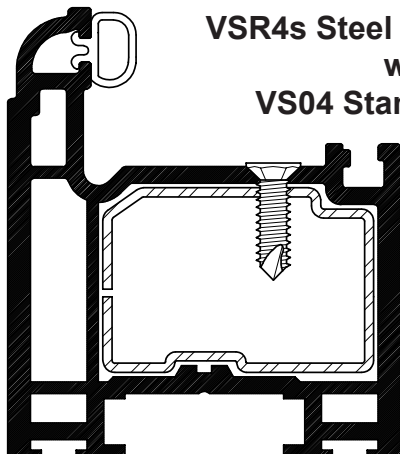

VSR4s Steel Reinforcement with VS04 Standard Sash.

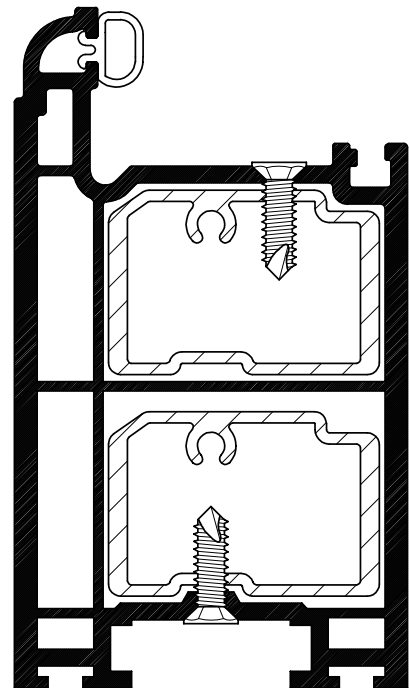

VSR4s Steel Reinforcement with VS05 Bottom Rail.

MECHANICAL JOINTS

Bottom Rail Assembly

Bottom Rail End Preparation :

The bottom rail should be end milled with the detail shown below. This ensures a flush joint with the side members of the sash.

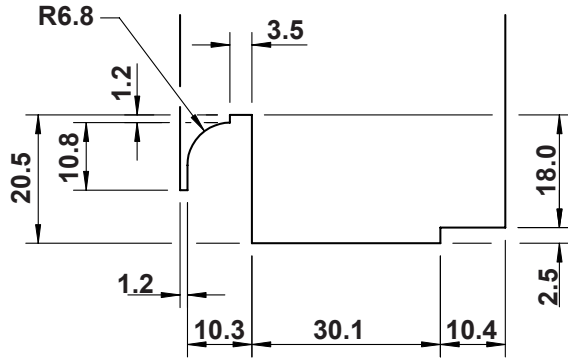

Drilling Details :

The two side members of the bottom sash must be prepared before the bottom rail is fixed to it. The bubble seal should be cut back 60mm (as shown), and then the profile should be pre-drilled using the VSJ05.

The jig (VSJ05) is located as shown. Two 5mm diameter holes are then drilled through the section, these are to provide clearance for the two screws used to mechanically join the bottom rail.

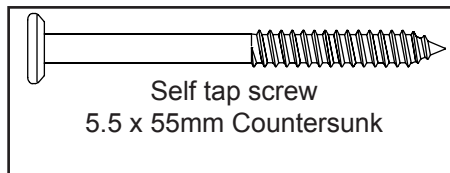
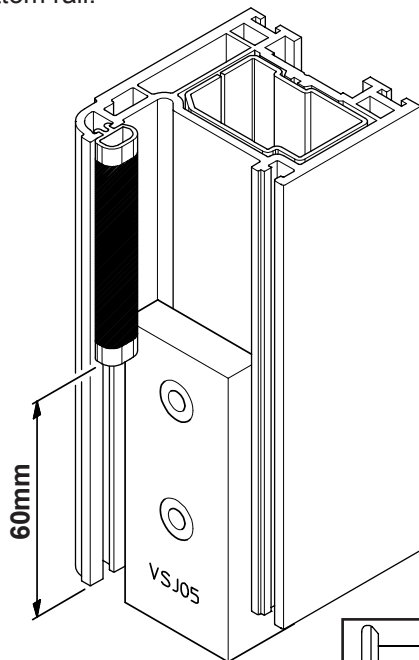

Bottom Rail & Sash Assembly :

The VSM06 mouldings (left & right handed) are required when assembling the bottom rail with the side members.

1) Insert the moulding into the bottom of the sash side member. The screws pass through the clearance holes in the moulding and into the screw ports in the side members profile.

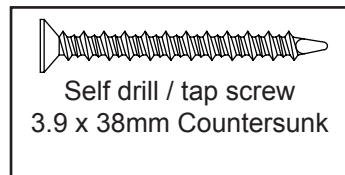
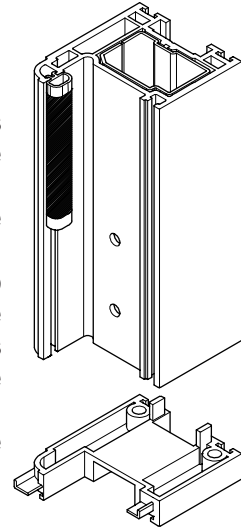

2) Locate the moulding in the bottom rail using the location lugs. Then using two screws, secure the side member to the bottom rail. The screws pass through the clearance holes in the side members and into the screw ports in the bottom rail reinforcement (VSR4S).

