

NOTES
Do not scale from this drawing unless for Planning purposes. Figured dimensions only are to be used. All dimensions must be checked on site by the Contractor prior to the commencement of any fabrication or building works. Where applicable, dimensions and details are to be read in conjunction with specialist consultants' drawings; any disparity between drawings is to be brought to the attention of Savills prior to the commencement of any fabrication or building works. This drawing is the property of Savills and may not be reproduced without their expressed permission.

REVISIONS

REV	NOTE / DRAWN BY	DATE
-----	-----------------	------

3030
floor plan of porch 1:50
dimensions taken to outside face of blockwork underbuilding

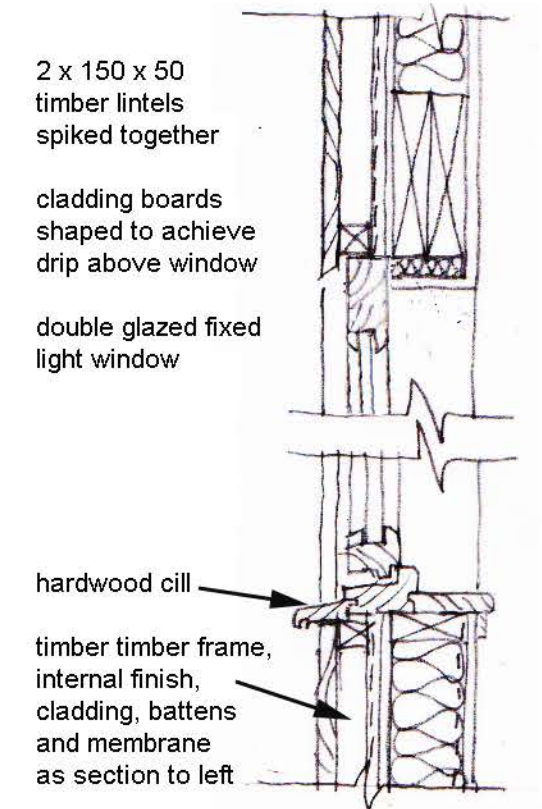
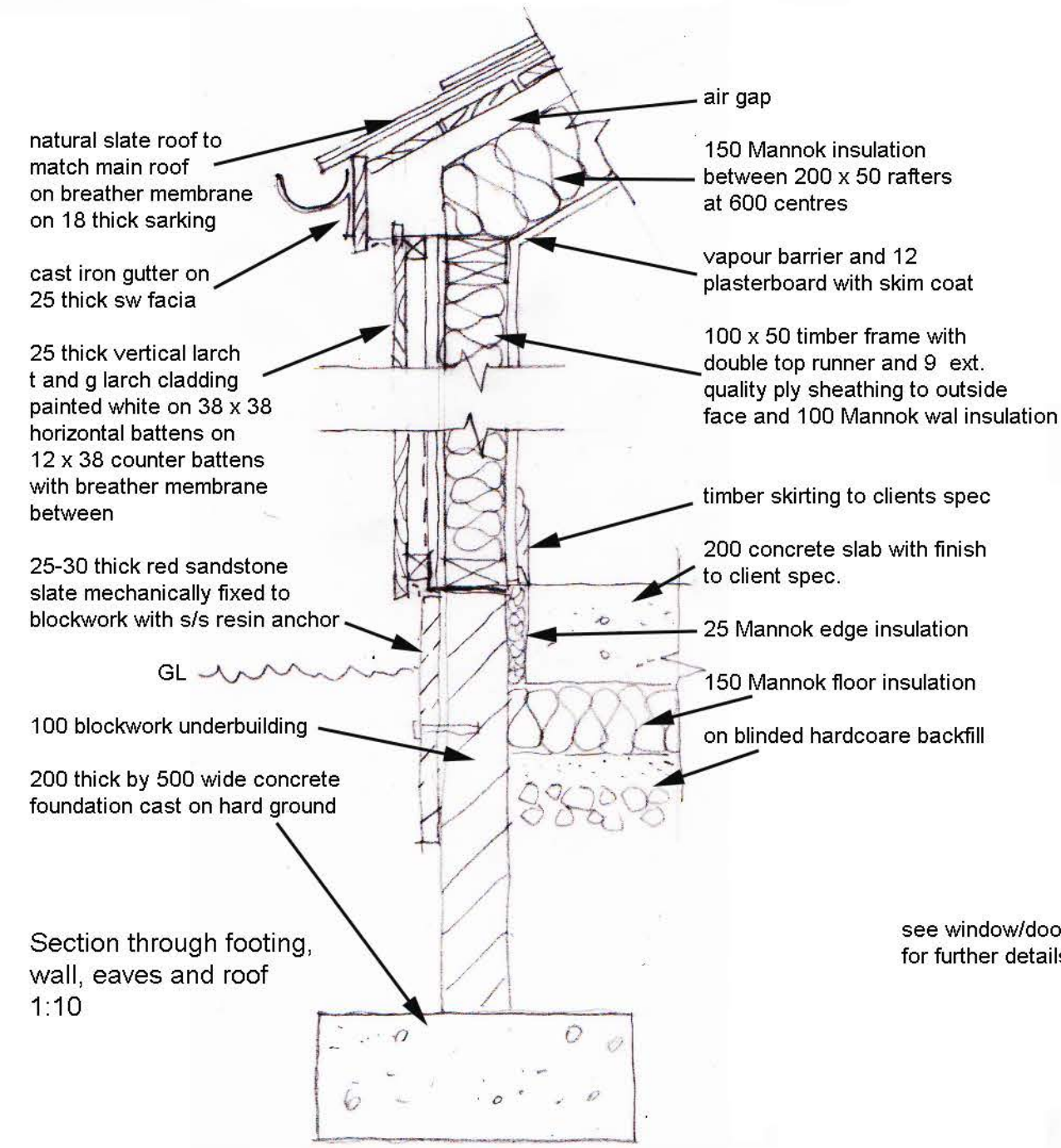
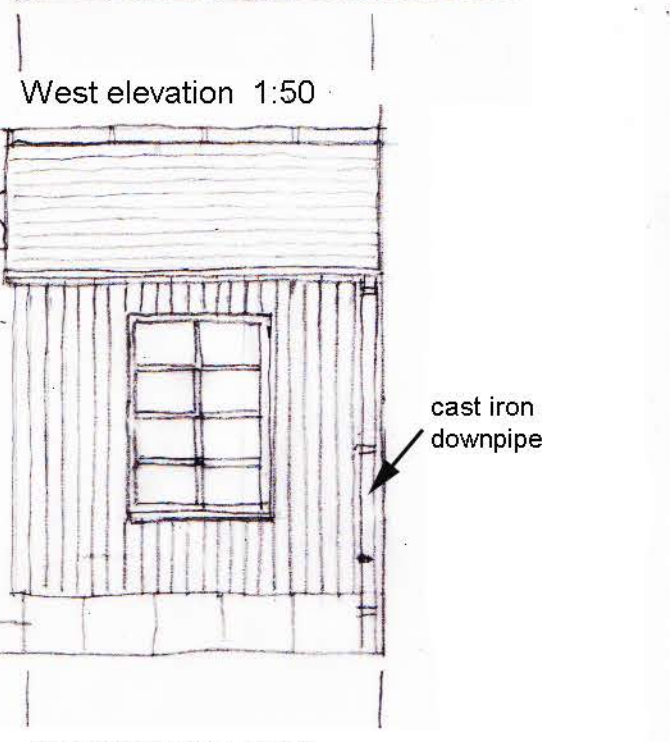
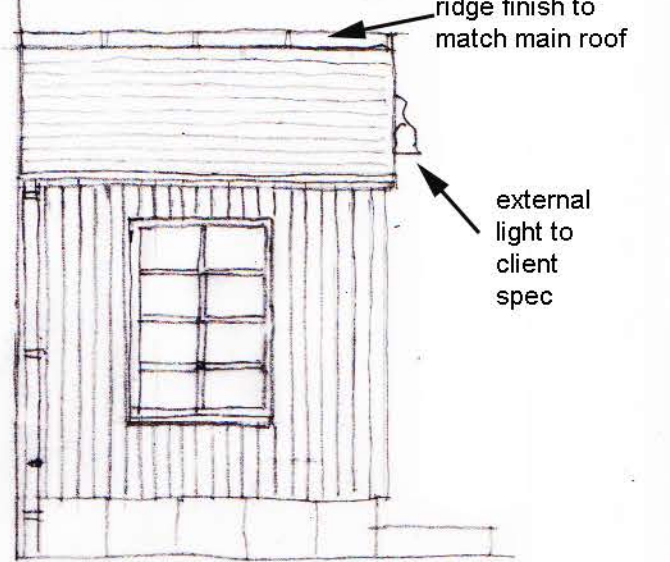

see window/door schedule BW05 for further details



PROJECT TITLE
Auchencairn Farmhouse

CLIENT
Mr Ian MacLellan

DRAWING TITLE
porch re-design clad in timber

SCALE	PAPER SIZE	DRAWING NUMBER	REVISION
1:50/1:10@A3		454833 - BW06	

DRAWING STATUS
LBC/Building Warrant

DRAWN BY	CHECKED BY	DATE
ML		270505