

lead cover flashing wraggled min 50 into stonework over lead soakers to slates

roof pitch approximately 30 degrees

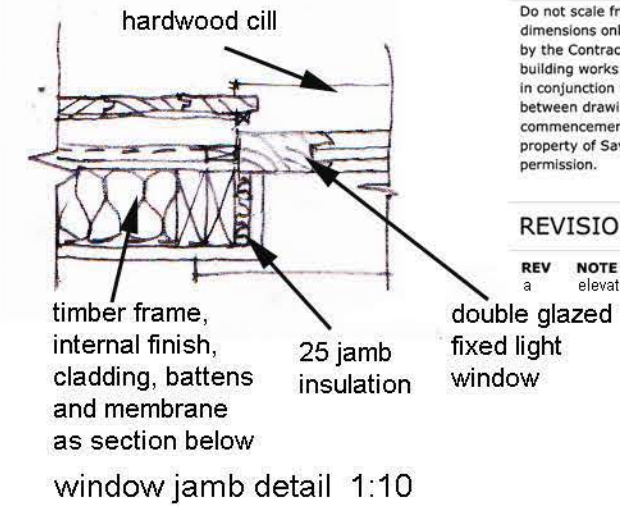
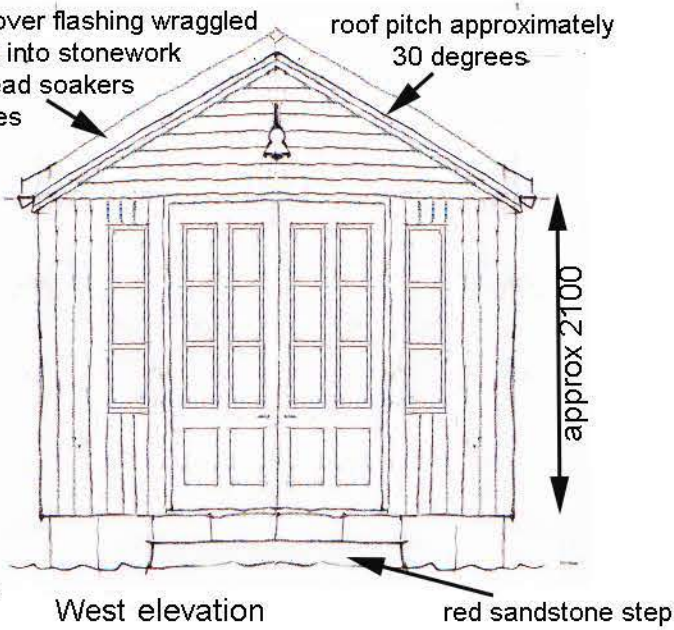

window jamb detail 1:10

NOTES

Do not scale from this drawing unless for Planning purposes. Figured dimensions only are to be used. All dimensions must be checked on site by the Contractor prior to the commencement of any fabrication or building works. Where applicable, dimensions and details are to be read in conjunction with specialist consultants' drawings; any disparity between drawings is to be brought to the attention of Savills prior to the commencement of any fabrication or building works. This drawing is the property of Savills and may not be reproduced without their expressed permission.

REVISIONS

REV	NOTE / DRAWN BY	DATE
a	elevation orientations corrected	16/06/21

3030
floor plan of porch 1:50
dimensions taken to outside face of blockwork underbuilding

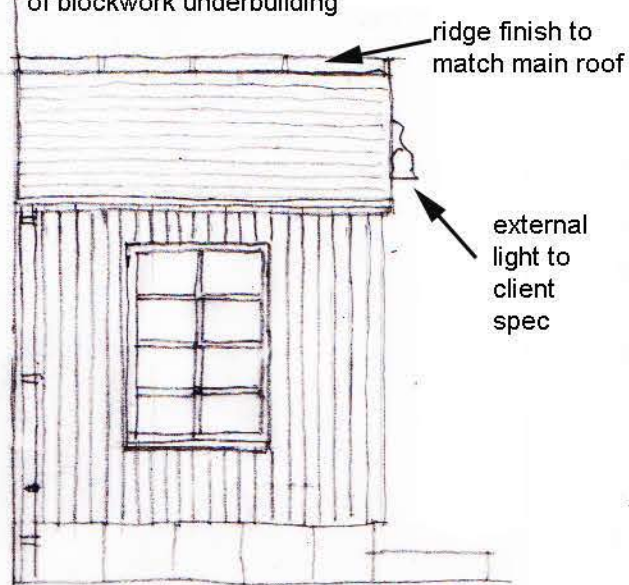

North elevation 1:50

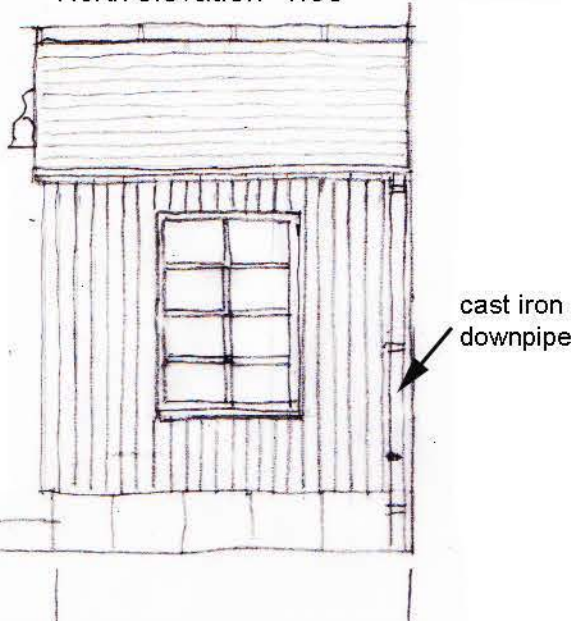

South elevation 1:50

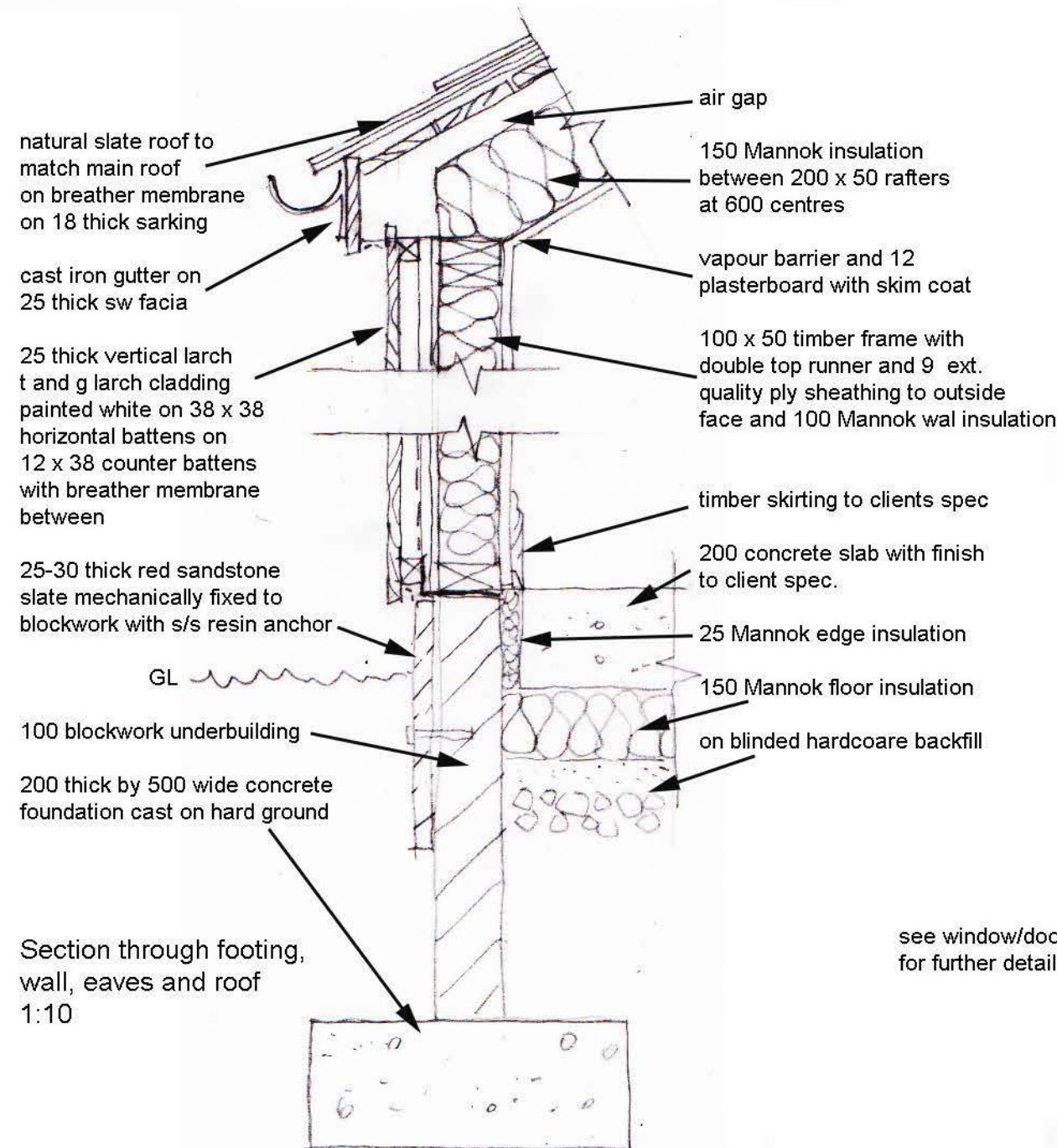

Section through footing, wall, eaves and roof 1:10

see window/door schedule BW05 for further details

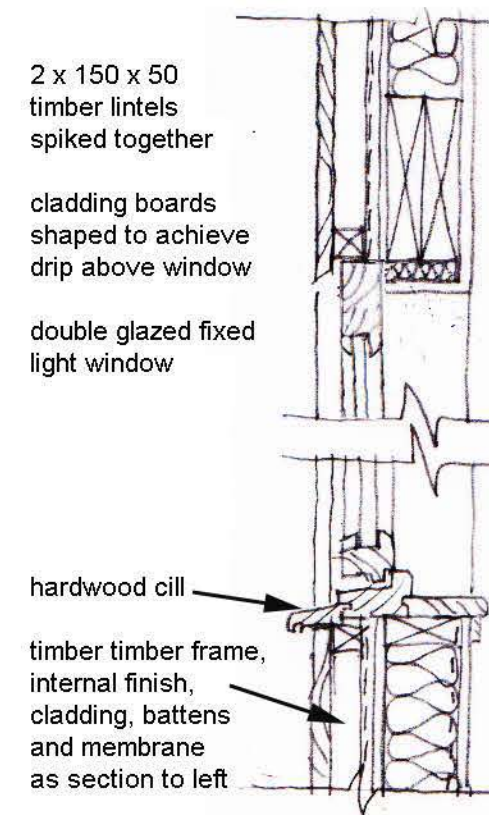

window cill and head detail 1:10



PROJECT TITLE
Auchencairn Farmhouse

CLIENT
Mr Ian MacLellan

DRAWING TITLE
porch re-design clad in timber

SCALE PAPER SIZE DRAWING NUMBER REVISION
1:50/1:10@A3 454833 - BW06 a

DRAWING STATUS
LBC/Building Warrant

DRAWN BY CHECKED BY DATE
ML 270505



28 Castle Street
Dumfries
DG1 1DG
t: 01387 263066
f: 01387 257103
e: dumfries@savills.com