

CNA-CNB CENTRIFUGAL FANS STANDARD TEMPERATURES AND EX



PRODUCT FACTS

PRODUCT

The centrifugal fans type CNA and CNB are robust and versatile fans of the single-inlet type with backward-curved blades.

APPLICATION

In industrial ventilation systems for uncontaminated, non-corrosive air, max. 70 °C, where a low sound level is required. The M-types are for corrosive environments. Versions for marine EX applications are also available.

RANGE

CNA: 9 installation sizes with impeller diameters from 250-1000 mm. Airflow rates from 0.2-14 m³/s and pressures up to 1000 Pa.

CNB: 7 installation sizes with impeller diameters from 400-1000 mm. Airflow rates from 0.8-18 m³/s and pressures up to 1500 Pa.

Part of the range is available as standard configurations in the Standard Range. The range comprises 10 fixed size-motor combinations.

CONSTRUCTION

Fan housing with rectangular side panels for universal installation. The housing is rotatable in 90° steps. The fans are available in direct driven and belt-driven versions.

MOTORS

Mounting: On base frame or on fan casing, depending on drive type and motor size

Terminal boxes: Part of motor housing

Dimension standard: IEC-72

Electrical standard: IEC-34

Enclosure: IP55, IP56 or IP65

Insulation: Class F

Structural shape: B3 and B14 for flanges

MATERIALS

Housing, CNA-CNB (standard and marine EX): Sendzimir galvanised (hot-dip galvanised) sheet steel, unpainted

Housing, CNA-M and CNB-M:

Sendzimir galvanised sheet steel with epoxy coating or aluzink

Impeller, CNA 250 to 630 (standard and marine EX):

Spot-welded, galvanised sheet steel, unpainted

Impeller, CNA 710 to 1000 (standard and marine EX):

Welded Corten sheet steel

Impeller, CNA-M 250 to 630:

Spot-welded, galvanised sheet steel, unpainted

Impeller, CNA-M 710 to 1000:

Welded Corten sheet steel

Impeller, CNB and CNB-M:

Welded Corten sheet steel, hot-dip galvanised

Inlet cone, CNA-CNB 250 to 630:

Galvanised deepdrawn sheet, unpainted

Inlet cone, CNA-CNB 710 to 1000:

Cast aluminium, unpainted

CLASSIFICATIONS

The fans meet the requirements for operation in unheated, low corrosion environments and are CE-certified.

Environment: DS/EN 12944-2, corrosion category C2

Technical capacity: BS 848:1980 and ISO 5801:1997, installation type D

Temperature range, standard:

-20 to 50 °C

Temperature range, max.:

-20 to 70 °C

Marine motor classification: Refer to AirBox program for available registers

Marine EX: Guidelines IACS F29/2005

Calculation software:

AirBox program is certified by TÜV.

ACCESSORIES

Installation

- Flexible connections
- Counter flange for outlet
- Duct spigots for inlet
- Anti-vibration mountings
- Common base frame (fan and motor)
- Suction box

Regulation

- Infinitely variable regulator (CNA 250 and 315 single-phase direct driven motor)
- 3-stage regulator (CNA 250 and 315 single-phase direct driven motor)
- 2-speed motor, 3-phase
- Frequency inverter, 3-phase motors

Protection

- Guard net (inlet and outlet)
- Inlet cone of brass (marine EX)
- Epoxy coating (CNA)

Service

- Inspection and access doors
- Drain plug

DESCRIPTION

Centrifugal fans of type CNA and CNB are light, compact low pressure fans, designed for universal installation in light industrial plants.

Type CNA is produced in 9 sizes with impeller diameters from 250-1000 mm, airflow rates from 0.2-14 m³/s and total pressures up to approximately 1000 Pa.

Type CNB is produced in 7 sizes with impeller diameters from 400-1000 mm and is designed for higher RPMs with airflow rates from 0.8-18 m³/s and total pressures up to 1500 Pa.

Centrifugal fans of type CNA and CNB consist of the following main components.

- Fan housing, constructed from two rectangular side panels and a casing.
- Inlet cone, mounted in the fan front side panel with a boss for duct connection and designed so that the air is conducted without loss to the impeller.
- Impeller with wide, backward curved blades.

BELT DRIVE

A bearing part with two dust and waterproof encapsulated deep groove ball bearings in a flanged bearing housing, mounted on the rear side panel of the fan, or two flanged bearings mounted in two covers. The bearing part in CNB 500 to -1000 must be relubricated. Other sizes have lifetime lubrication.

SURFACE TREATMENT

All fan parts are protected against standard corrosive action.

ACCESSORIES

Motor according to specifications

Motor panel for installing motors up to the sizes stated on page 7 on the fan

housing flanges. The motor panel can be adjusted to tighten the belts.

Belt drive, consisting of pulleys, V-belts and belt guards

Flexible connections for the inlet boss and outlet flange

Counter flange for the outlet flange

Duct spigot for installation on the fan inlet boss. The inlet flange is also used to connect a flexible connection to the inlet guide vane arrangement.

Anti-vibration mountings for fitting between fan or base frame and foundation

Common base frame for installing motors over the sizes stated on page 6 beside the fan.

Sizes -250, -315 and -400 are also available with a direct driven flanged motor installed on the fan rear side panel.

Sizes -500 and -630 are also available with a direct driven base motor installed on a motor bracket.

Suction box for outlet and universal connection to duct system

Guard net for the inlet opening

Inlet cone of brass for marine EX.

Epoxy coating (CNA) in any colour

Inspection hatch placed in the casing of the fan housing

Drain plug, see page 7.

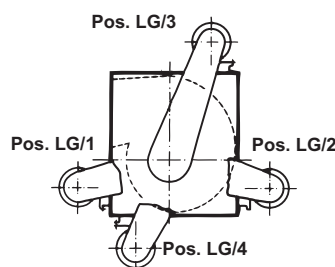
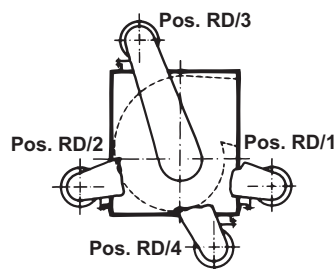

SCROLL POSITIONS

Direction of rotation RD or LG. Motor positions 1, 2, 3 and 4 indicate the position of the motor in relation to the outlet opening.

MARINE EX APPLICATIONS

The complete range of CNA and CNB is available as marine EX fans that follow the guidelines in IACS F29/2005 for non-sparking fans. The fans have brass inlet cones and are well-suited for transport of air containing flammable gases.

AIRBOX CALCULATION PROGRAM

The AirBox program is Novenco's calculation and configuration tool. Input to the program are requirements for airflow and pressure as well as specific characteristics of the operating environment. Further requirements for the fan, motor and accessories are also input and form the basis for calculation of possible solutions.

Novenco AirBox is free and available on www.novenco-building.com. It is certified by TÜV Süd in Germany, requires registration and checks automatically for updates.

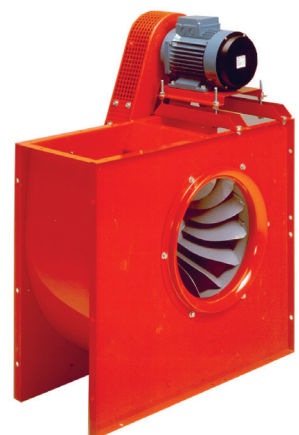

STANDARD RANGE

The composition of the Standard Range is based on sales statistics. It represents the most commonly sold fan sizes and requested performances.

The range covers 10 pre-configured CNA fan configurations. These standards have lower prices and shorter delivery times compared to custom configurations. Accessories are available on the same terms as for custom configurations.

Fans in the Standard Range operate in the temperature area between -20 and 50 °C. The standardisation comprises impeller diameters, rotation directions, motors and other constructional parameters. The motors are all direct

driven and the inlets and outlets are to ducts.

All Standard Range fans are available in AirBox and calculate the same way as the custom configurations. The standard configurations in AirBox block for modifications, which means that accessories are ordered separately and not from within AirBox.

| Item no. | Fan size [mm] | Rotational direction ¹ | Airflow [m ³ /s] | Airflow [m ³ /h] | Total pressure [Pa] | Static pressure [Pa] | Power input [kW] | Fan RPM | Fan max. RPM | | | |
|----------|---------------|-----------------------------------|-----------------------------|-----------------------------|---------------------|----------------------|------------------|---------|--------------|-------|-------|------|
| 30044121 | Ø250 | Left | 0.50 | 1800 | 483 | 404 | 0.455 | 2282 | 3600 | | | |
| 30044122 | | Right | | | | | | | | | | |
| 30044123 | | Left | 0.70 | 2520 | | | | 1000 | | 846 | 1.208 | 3263 |
| 30044124 | | Right | | | | | | | | | | |
| 30044125 | Ø315 | Left | 0.42 | 1512 | 500 | 478 | 0.426 | | 1736 | | | 3000 |
| 30044126 | | Right | | | | | | | | | | |
| 30044127 | | Left | 0.70 | 2520 | | | | 1000 | 939 | 1.205 | 2454 | |
| 30044128 | | Right | | | | | | | | | | |
| 30044129 | Ø400 | Left | 0.80 | 2880 | 823 | 792 | 1.204 | | | | 1724 | 1950 |
| 30044130 | | Right | | | | | | | | | | |

DATA FOR STANDARD RANGE FANS AT SELECTED CONDITIONS

1. The rotational direction is from the motor side.

PERFORMANCE CURVES

The basis for dimensioning is the air-flow rate and the pressure loss in the ventilation system in question = the fan static pressure, $p_s = p_{s2} - p_{s1}$. To establish the fan total pressure p_t , add the air speed pressure, the dynamic pressure p_d at the outlet and the installation loss at the inlet p_1 and outlet p_2 . These values are stated in connection with the dimensioning graphs on pages 9 to 13. All graphs are plotted for arrangement D.

CHOICE OF MOTOR

The power consumption in the dimensioning graphs refers to the fan shaft. To cover the loss in the belt drive, bearing parts and more, the power consumption reading is increased by factor C_1 .

C_1 depends on the fan size.

315-630 : $C_1 = 1.2$

710-1000 : $C_1 = 1.1$

DIMENSIONING EXAMPLE

Arrangement D

Duct for the inlet and outlet

Airflow rate $q_v = 1.75 \text{ m}^3/\text{s}$.

$p_{s2} - p_{s1} = 1300 \text{ Pa}$

The graph on page 11 shows that type CNB 400 is best suited.

The graph shows the following:

Fan speed: 2300 RPM

Efficiency: 72%

Power demand: 3.5 kW

Correction: $2.3 \times 1.2 = 4.2 \text{ kW}$

Choice of motor: 5.5 kW

| | | |
|-------------------|---|---------|
| $p_{s2} - p_{s1}$ | = | 1300 Pa |
| + p_d | = | 155 Pa |
| Total pressure | = | 1455 Pa |

ARRANGEMENT A

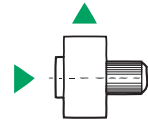

| | | |
|-------------------|---|----|
| $P_{s2} - P_{s1}$ | = | Pa |
| + p_1 | = | Pa |
| + $p_d + P_2$ | = | Pa |
| Total pressure | = | Pa |

ARRANGEMENT C

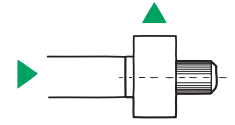

| | | |
|-------------------|---|----|
| $P_{s2} - P_{s1}$ | = | Pa |
| + $p_d + P_2$ | = | Pa |
| Total pressure | = | Pa |

ARRANGEMENT B

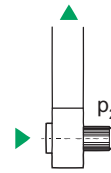

| | | |
|-------------------|---|----|
| $P_{s2} - P_{s1}$ | = | Pa |
| + P_1 | = | Pa |
| + p_d | = | Pa |
| Total pressure | = | Pa |

ARRANGEMENT D

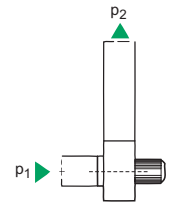

| | | |
|-------------------|---|----|
| $P_{s2} - P_{s1}$ | = | Pa |
| + p_d | = | Pa |
| Total pressure | = | Pa |

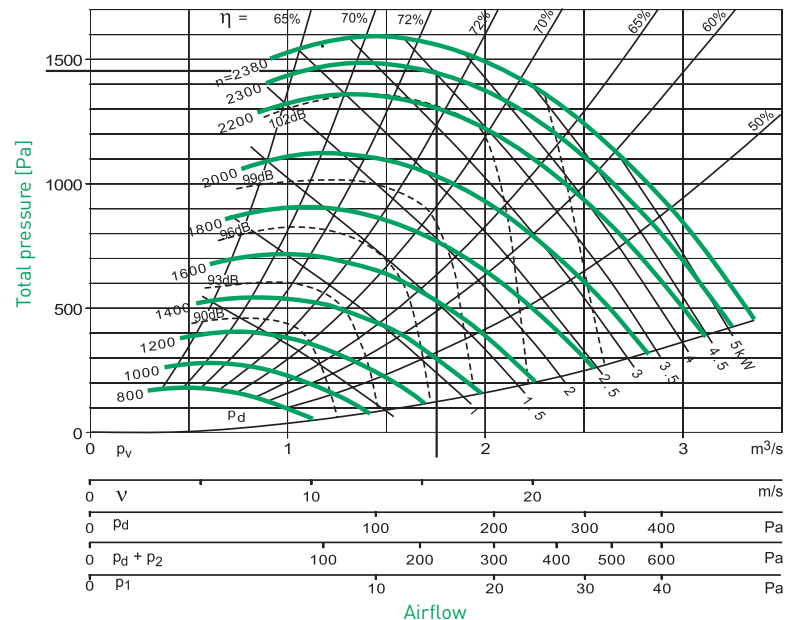

CNA 250

Max. = 3150 RPM (belt-driven)
 Max. = 3600 RPM (direct driven)
 $\rho = 1.20 \text{ kg/m}^3$
 $I_v = 0.025 \text{ kgm}^2$

CIRCUMFERENTIAL SPEED

$u = 0.013 \times n, \text{ m/s}$

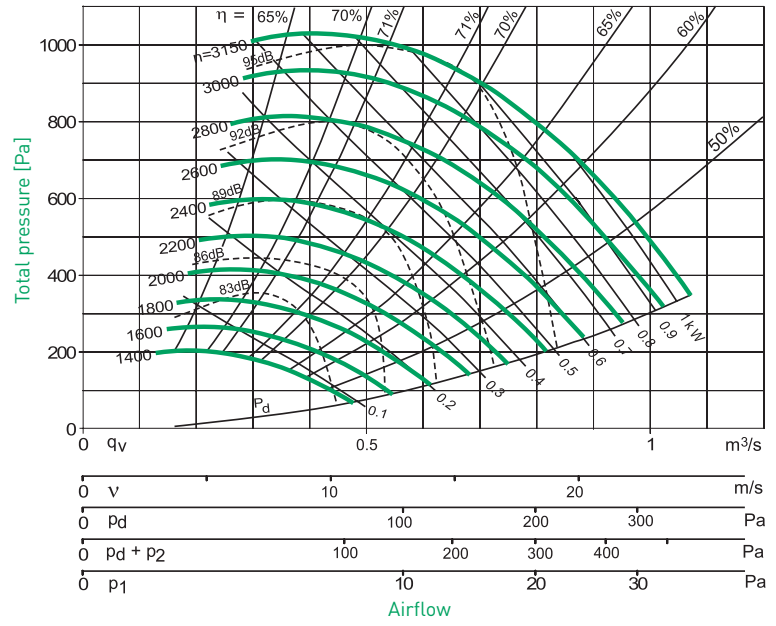

CNA 315

Max. = 3000 RPM
 $\rho = 1.20 \text{ kg/m}^3$
 $I_v = 0.05 \text{ kgm}^2$

CIRCUMFERENTIAL SPEED

$u = 0.016 \times n, \text{ m/s}$

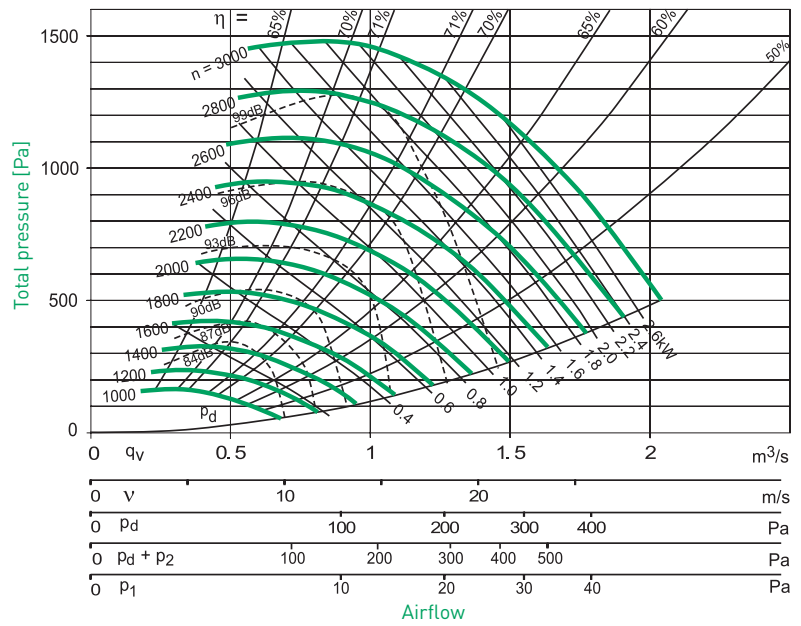

BASIS FOR CHART

(Arr. D)

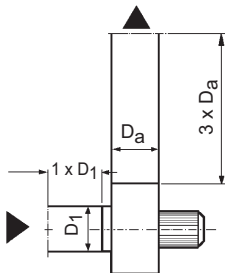

SYMBOLS

| | | | |
|-------|----------------------------|--------|-----------------------------|
| p_t | = total pressure | q_v | = airflow |
| p_d | = dynamic pressure, outlet | n | = RPM |
| p_1 | = connection loss, inlet | η | = efficiency in % |
| p_2 | = connection loss, outlet | kW | = power demand, impeller |
| v | = air speed, outlet | dB | = sound power level, outlet |

CNA 400

max. = 1950 RPM
 $\rho = 1.20 \text{ kg/m}^3$
 $l_v = 0.175 \text{ kgm}^2$

CNB 400

max. = 2380 RPM
 $\rho = 1.20 \text{ kg/m}^3$
 $l_v = 0.3 \text{ kgm}^2$

CIRCUMFERENTIAL SPEED

$u = 0.021 \times n, \text{ m/s}$

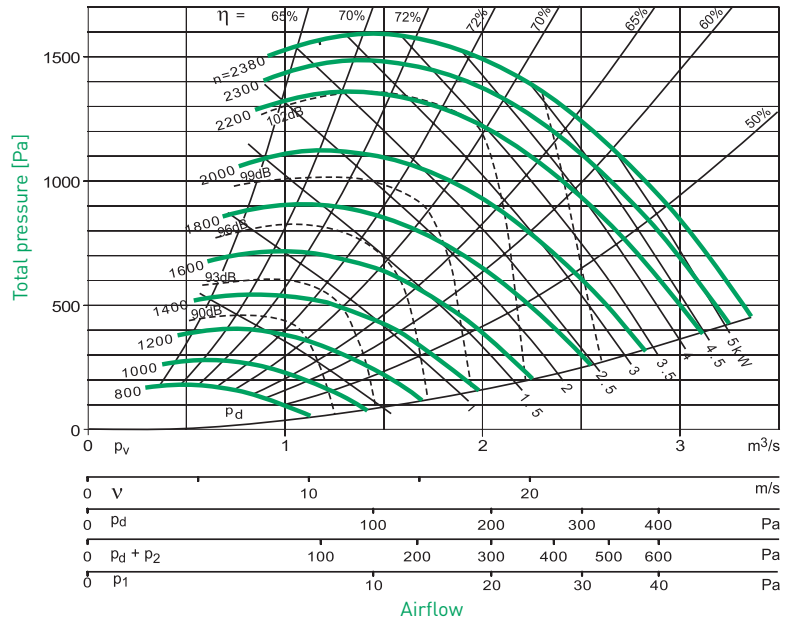

CNA 500

max. = 1575 RPM
 $\rho = 1.20 \text{ kg/m}^3$
 $l_v = 0.55 \text{ kgm}^2$

CNB 500

max. = 1925 RPM
 $\rho = 1.20 \text{ kg/m}^3$
 $l_v = 0.75 \text{ kgm}^2$

CIRCUMFERENTIAL SPEED

$u = 0.026 \times n, \text{ m/s}$

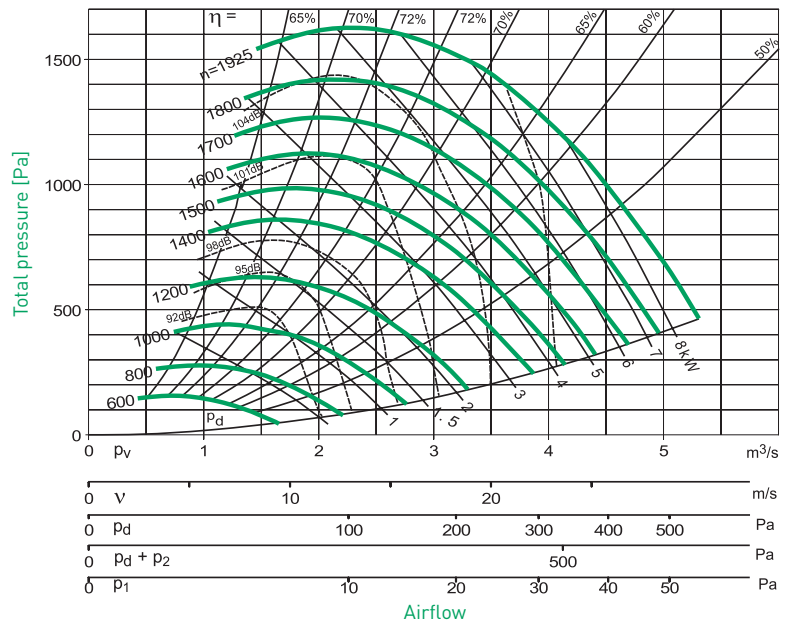

BASIS FOR CHART

(Arr. D)

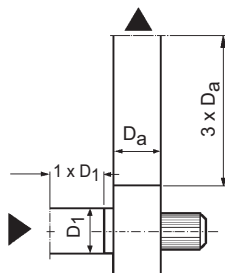

SYMBOLS

- | | | | |
|-------|----------------------------|--------|-----------------------------|
| p_t | = total pressure | q_v | = airflow |
| p_d | = dynamic pressure, outlet | n | = RPM |
| p_1 | = connection loss, inlet | η | = efficiency in % |
| p_2 | = connection loss, outlet | kW | = power demand, impeller |
| v | = air speed, outlet | dB | = sound power level, outlet |

CNA 630

max. = 1240 RPM
 $\rho = 1.20 \text{ kg/m}^3$
 $I_v = 1.35 \text{ kgm}^2$

CNB 630

max. = 1515 RPM
 $\rho = 1.20 \text{ kg/m}^3$
 $I_v = 1.85 \text{ kgm}^2$

CIRCUMFERENTIAL SPEED

$u = 0.033 \times n, \text{ m/s}$

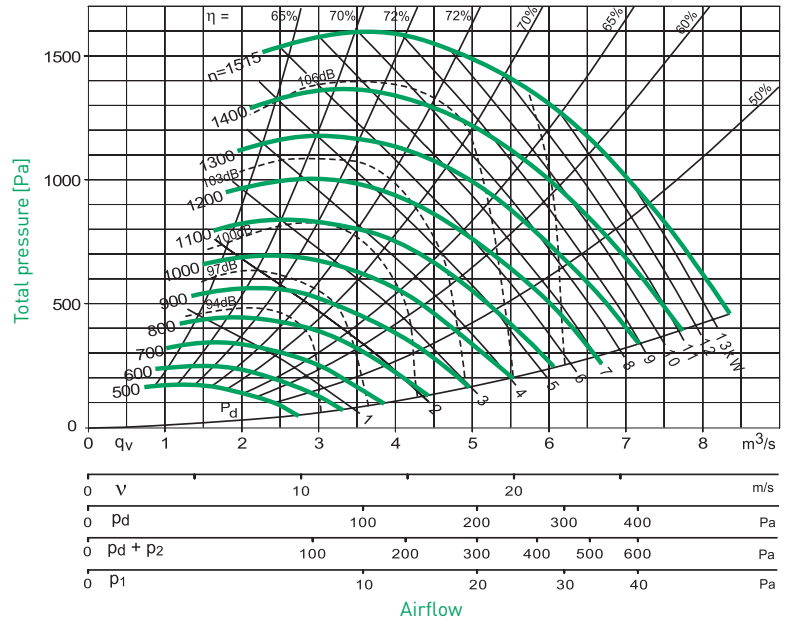

CNA 710

max. = 1105 RPM
 $\rho = 1.20 \text{ kg/m}^3$
 $I_v = 3 \text{ kgm}^2$

CNB 710

max. = 1350 RPM
 $\rho = 1.20 \text{ kg/m}^3$
 $I_v = 3 \text{ kgm}^2$

CIRCUMFERENTIAL SPEED

$u = 0.037 \times n, \text{ m/s}$

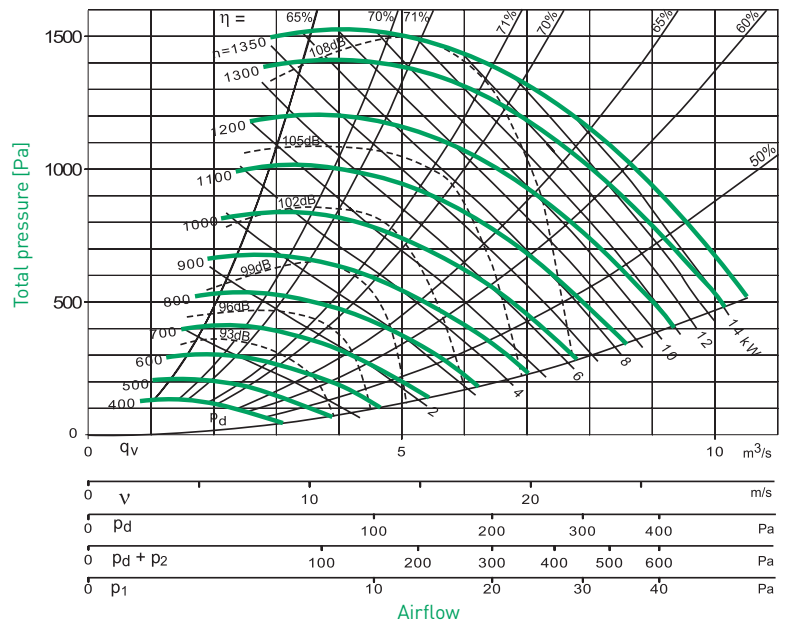

BASIS FOR CHART

(Arr. D)

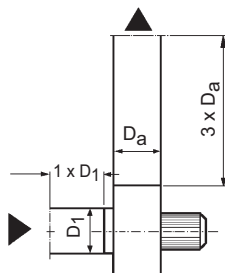

SYMBOLS

- | | | | |
|-------|----------------------------|--------|-----------------------------|
| p_t | = total pressure | q_v | = airflow |
| p_d | = dynamic pressure, outlet | n | = RPM |
| p_1 | = connection loss, inlet | η | = efficiency in % |
| p_2 | = connection loss, outlet | kW | = power demand, impeller |
| v | = air speed, outlet | dB | = sound power level, outlet |

CNA 800

max. = 975 RPM
 $\rho = 1.20 \text{ kg/m}^3$
 $I_v = 5 \text{ kgm}^2$

CNB 800

max. = 1190 RPM
 $\rho = 1.20 \text{ kg/m}^3$
 $I_v = 5 \text{ kgm}^2$

CIRCUMFERENTIAL SPEED

$u = 0.042 \times n, \text{ m/s}$

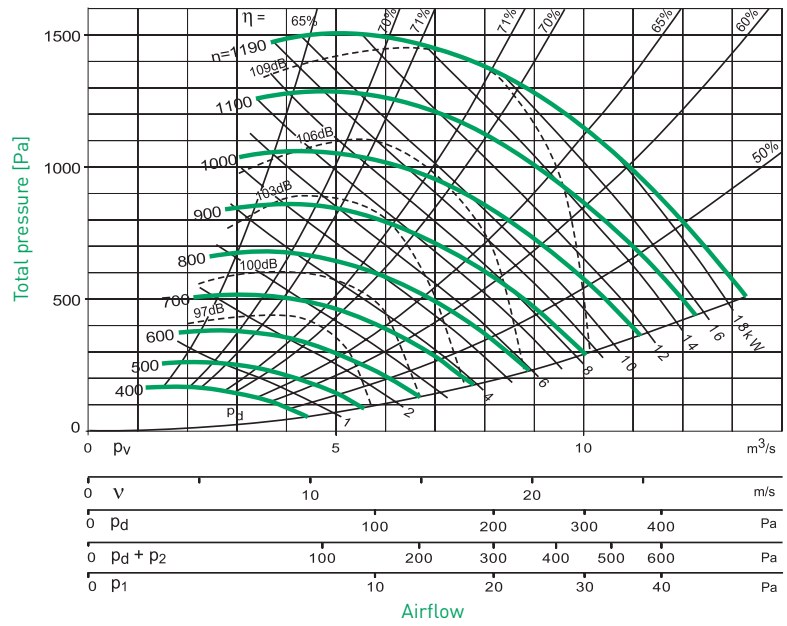

CNA 900

max. = 870 RPM
 $\rho = 1.20 \text{ kg/m}^3$
 $I_v = 7.75 \text{ kgm}^2$

CNB 900

max. = 1065 RPM
 $\rho = 1.20 \text{ kg/m}^3$
 $I_v = 7.75 \text{ kgm}^2$

CIRCUMFERENTIAL SPEED

$u = 0.047 \times n, \text{ m/s}$

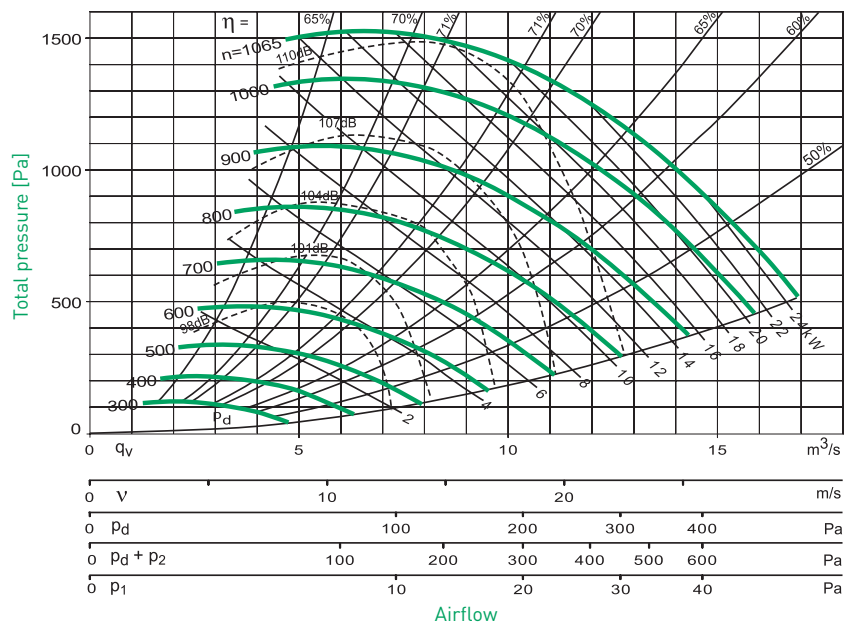

BASIS FOR CHART

(Arr. D)

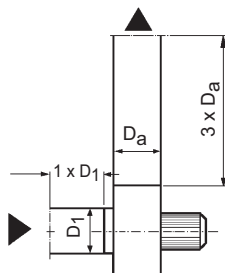

SYMBOLS

- | | | | |
|-------|----------------------------|--------|-----------------------------|
| p_t | = total pressure | q_v | = airflow |
| p_d | = dynamic pressure, outlet | n | = RPM |
| p_1 | = connection loss, inlet | η | = efficiency in % |
| p_2 | = connection loss, outlet | kW | = power demand, impeller |
| v | = air speed, outlet | dB | = sound power level, outlet |

CNA 1000

max. = 785 RPM
 $\rho = 1.20 \text{ kg/m}^3$
 $I_v = 14 \text{ kgm}^2$

CNB 1000

max. = 960 RPM
 $\rho = 1.20 \text{ kg/m}^3$
 $I_v = 14 \text{ kgm}^2$

CIRCUMFERENTIAL SPEED

$u = 0.052 \times n, \text{ m/s}$

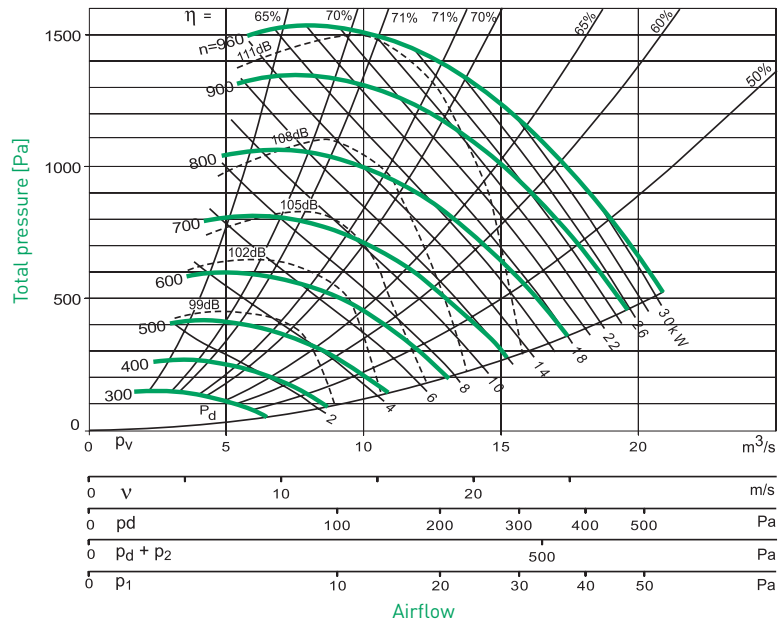

BASIS FOR CHART

(Arr. D)

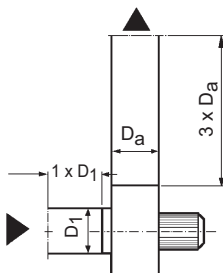

SYMBOLS

| | | | |
|-------|----------------------------|--------|-----------------------------|
| p_t | = total pressure | q_v | = airflow |
| p_d | = dynamic pressure, outlet | n | = RPM |
| p_1 | = connection loss, inlet | η | = efficiency in % |
| p_2 | = connection loss, outlet | kW | = power demand, impeller |
| v | = air speed, outlet | dB | = sound power level, outlet |

DIMENSIONS

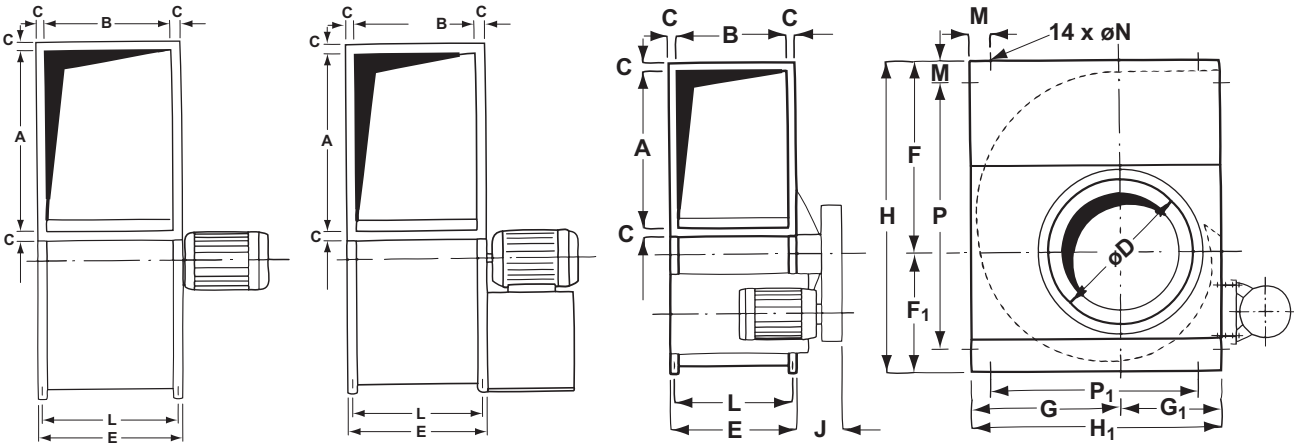

Direct driven
CNA 250, -315, -400
CNB 400

CNA 500, -630
CNB 500, -630

Belt-driven
all sizes

| CNA CNB | DIMENSIONS [mm] | | | | | | | | | | | | | | | | | Weight ¹ [kg] | |
|------------|-----------------|-----|----|------|-----|------|----------------|-----|----------------|------|----------------|-----|-----|------|----|------|----------------|--------------------------|-----|
| | A | B | C | D | E | F | F ₁ | G | G ₁ | H | H ₁ | J | L | M | N | P | P ₁ | CNA | CNB |
| -250 | 250 | 175 | 30 | 250 | 235 | 310 | 250 | 245 | 200 | 560 | 445 | 150 | 207 | 60 | 12 | 440 | 325 | 22 | - |
| -315 | 315 | 220 | 30 | 315 | 280 | 410 | 280 | 345 | 250 | 690 | 595 | 160 | 252 | 100 | 12 | 490 | 395 | 35 | - |
| -400 | 400 | 280 | 30 | 400 | 340 | 485 | 315 | 400 | 300 | 800 | 700 | 145 | 312 | 100 | 12 | 600 | 500 | 53 | 55 |
| -500 | 500 | 350 | 35 | 500 | 420 | 600 | 400 | 500 | 350 | 1000 | 850 | 170 | 392 | 125 | 15 | 750 | 600 | 89 | 98 |
| -630 | 630 | 440 | 35 | 630 | 510 | 758 | 488 | 623 | 440 | 1246 | 1063 | 250 | 482 | 125 | 15 | 996 | 813 | 146 | 161 |
| -710 | 710 | 497 | 40 | 710 | 577 | 870 | 535 | 670 | 465 | 1405 | 1135 | 260 | 537 | 62.5 | 15 | 1280 | 1010 | 238 | 262 |
| -800 | 800 | 560 | 40 | 800 | 640 | 976 | 604 | 754 | 516 | 1580 | 1270 | 280 | 600 | 85 | 15 | 1410 | 1100 | 304 | 334 |
| -900 | 900 | 630 | 45 | 900 | 720 | 1098 | 680 | 847 | 573 | 1778 | 1420 | 300 | 680 | 110 | 15 | 1558 | 1200 | 350 | 385 |
| -1000 | 1000 | 700 | 45 | 1000 | 790 | 1215 | 750 | 940 | 640 | 1965 | 1580 | 360 | 750 | 90 | 15 | 1785 | 1400 | 487 | 535 |

1. Weights excl. motors and belt drive

OUTLET FLANGES

| CNA CNB | P | R | S | T |
|------------|-----|-----|------|-------|
| -250 | 207 | 85 | 282 | 110 |
| -315 | 252 | 110 | 347 | 142.5 |
| -400 | 312 | 140 | 432 | 185 |
| -500 | 386 | 125 | 536 | 155 |
| -630 | 476 | 170 | 666 | 200 |
| -710 | 537 | 150 | 750 | 170 |
| -800 | 600 | 170 | 840 | 175 |
| -900 | 680 | 195 | 950 | 200 |
| -1000 | 750 | 160 | 1050 | 180 |

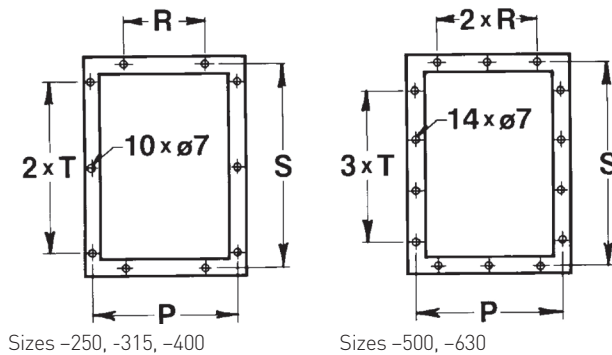

Sizes -250, -315, -400

Sizes -500, -630

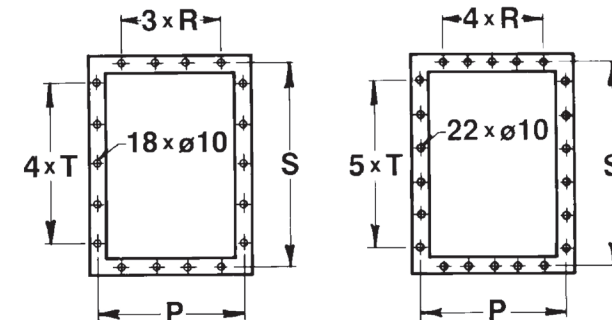

Sizes -710, -800, -900

Size -1000

Counter flanges (4 rails) with the same bolt holes as the outlet flanges are available as accessories.

Ducts are made with the same internal dimensions as the fan outlet opening (A x B).

See dimensions above.

POSITION DESIGNATIONS

Fan positions in connection with installation on a common base frame must be indicated in accordance with Eurovent.

DIRECT DRIVEN

Motor installed on fan housing

Position RD 0

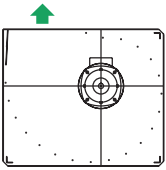

Position RD 90

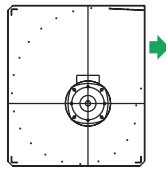

Position RD 180

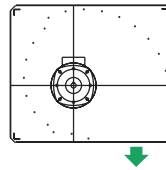

Position RD 270

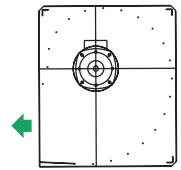

Position LG 0

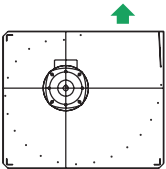

Position LG 90

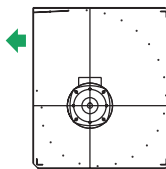

Position LG 180

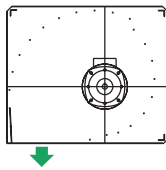

Position LG 270

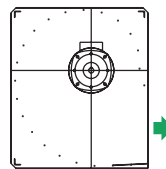

BELT-DRIVEN

Low motor bracket for belt drive

Position LG/1

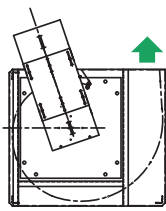

Position LG/2

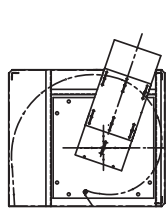

Position LG/3

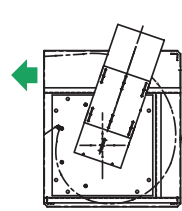

Position LG/4

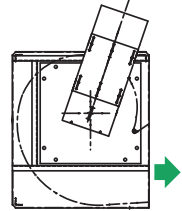

Position RD/1

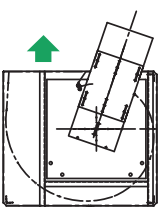

Position RD/2

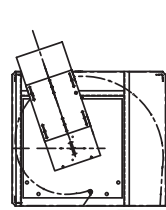

Position RD/3

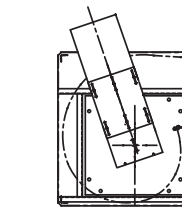

Position RD/4

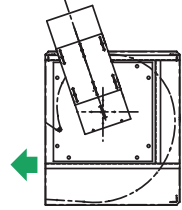

Positions in accordance with Eurovent seen from the motor side

MOTORS

Installation

The tables show the maximum motor size that can be installed directly on the fan.

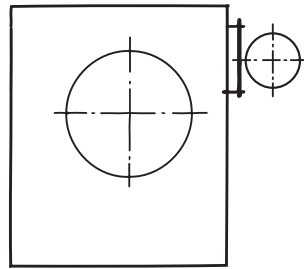

Motor on the side
- vertical motor panel

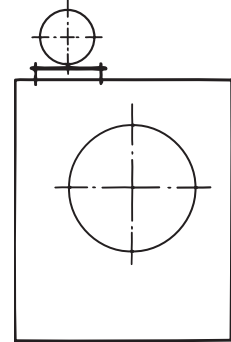

Motor on the top
- horizontal motor panel

MOTOR SIZES DIRECT DRIVEN

| FAN SIZE | MOTOR INSTALLATION SIZE |
|-----------|-------------------------|
| CNA 250 | 71-90 |
| CNA 315 | 71-100 |
| CNA/B 400 | 80-100 |
| CNA/B 500 | 112-132 |
| CNA 630 | 132 |
| CNB 630 | 160 |

250-400 Design B14 small
500-630 Design B3

BELT-DRIVEN

| CNA CNB | MAX. MOTOR | |
|------------|------------|-------------|
| | TYPE | WEIGHT (kg) |
| -250 | 90 | 20 |
| -315 | 112 | 40 |
| -400 | 112 | 40 |
| -500 | 132 | 70 |
| -630 | 132 | 70 |
| -710 | 132 | 70 |
| -800 | 132 | 70 |
| -900 | 132 | 70 |
| -1000 | 132 | 70 |

BELT-DRIVEN

| CNA CNB | MAX. MOTOR | |
|------------|------------------|-------------|
| | TYPE | WEIGHT (kg) |
| -250 | 90 | 20 |
| -315 | 112 | 40 |
| -400 | 112 | 40 |
| -500 | 132 | 70 |
| -630 | 132 | 70 |
| -710 | 160 | 140 |
| -800 | 160 | 140 |
| -900 | 180 ¹ | 190 |
| -1000 | 180 | 190 |

1. CNA max. 160

Base frame for fan and motor

Large motors are installed on clamp rails beside the fan. A common base frame for the fan and motor, as shown in the drawings, is available. Please state the desired motor position (pos. W or Z).

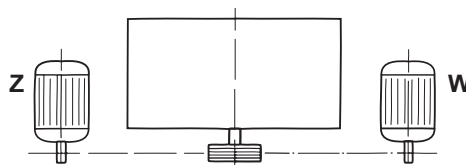
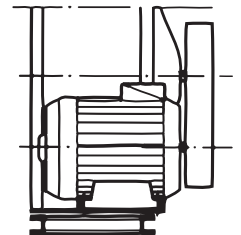
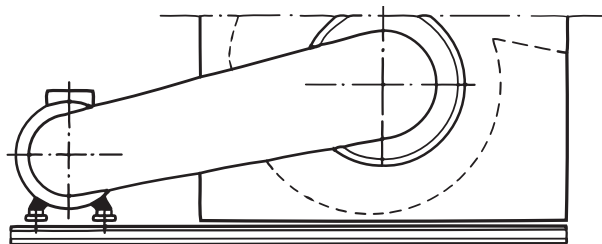

SHAFT END FOR BELT DRIVE

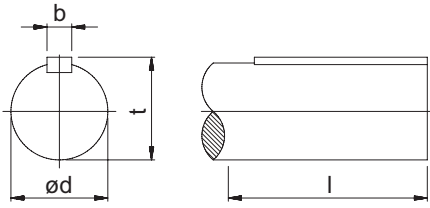

| CNA | d | l | b | t |
|-------|------|-----|----|----|
| -250 | 24j6 | 50 | 8 | 27 |
| -315 | 24j6 | 50 | 8 | 27 |
| -400 | 24j6 | 50 | 8 | 27 |
| -500 | 28j6 | 50 | 8 | 31 |
| -630 | 32k6 | 60 | 10 | 35 |
| -710 | 35h8 | 100 | 10 | 38 |
| -800 | 40h8 | 100 | 12 | 43 |
| -900 | 40h8 | 100 | 12 | 43 |
| -1000 | 55h8 | 100 | 16 | 59 |

| CNB | d | l | b | t |
|-------|------|-----|----|------|
| -250 | - | - | - | - |
| -315 | - | - | - | - |
| -400 | 28jk | 50 | 8 | 31 |
| -500 | 38k6 | 90 | 10 | 41 |
| -630 | 48k6 | 90 | 14 | 51.5 |
| -710 | 55m6 | 100 | 16 | 59 |
| -800 | 55m6 | 100 | 16 | 59 |
| -900 | 60m6 | 115 | 18 | 64 |
| -1000 | 60m6 | 115 | 18 | 64 |

ACCESSORIES

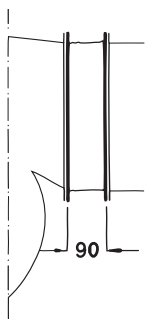

Flexible connection, outlet

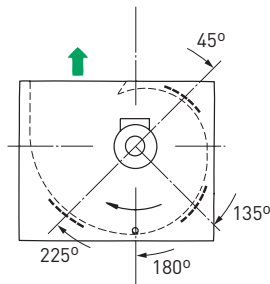

Drain plug Inspection hatch

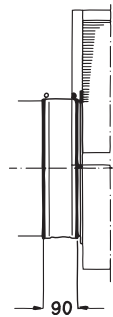

Flexible connection, inlet

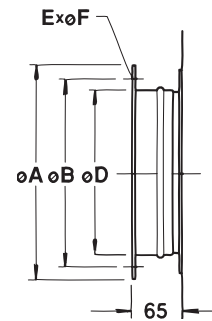

Duct spigot

| CNA | A | B | D | E | F |
|-------|------|------|------|----|----|
| -250 | 310 | 280 | 250 | 4 | 10 |
| -315 | 385 | 355 | 315 | 8 | 10 |
| -400 | 480 | 450 | 400 | 8 | 12 |
| -500 | 590 | 560 | 500 | 12 | 12 |
| -630 | 720 | 690 | 630 | 12 | 12 |
| -710 | 790 | 765 | 710 | 10 | 14 |
| -800 | 880 | 850 | 800 | 10 | 14 |
| -900 | 1000 | 970 | 900 | 16 | 14 |
| -1000 | 1080 | 1050 | 1000 | 16 | 14 |

Type CNA and CNB are available with inspection hatches in the fan housing and with drain bosses.

Example:

Inspection hatch pos. RD 135
Drain plug pos. RD 180

The hatches can be placed at angles of 45°, 135° or 225° from the outlet. The drain plug must always be at the lowest point in the housing.

Hatches are available for both types and sizes 250-630. Refer to the AirBox software for configuration.

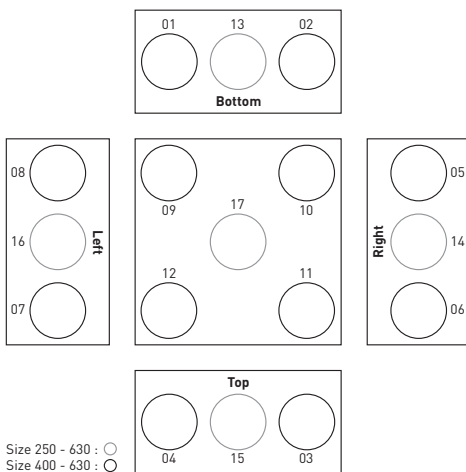

Size 250 - 630 : ○
Size 400 - 630 : ○

Suction box

The suction box fits on the fan outlet and allows for universal connection to an existing duct system.

The positions and specifications of the duct connections are specified with the AirBox program

SOUND CONDITIONS

When a fan is operated, sound is generated. This is partly electrical and mechanical sound in the motor, bearings and other mechanical parts, partly air sound that occurs as the air flows through the fan.

Sound generation is counteracted by the correct design and careful production of fan parts, in particular the inlet cone and impeller, where air sound is concerned. In this connection, it must be noted that poor installation conditions, for example a sharp duct bend immediately before the inlet opening, may increase sound generation considerably.

The electrical and mechanical sound, and that part of the air sound that passes out through the fan housing, can only be dampened by surrounding the fan with a casing or walls of low-vibration (heavy) materials.

The sound generated in the impeller is distributed through the inlet and outlet openings to the duct system and on to the ventilated rooms.

Calculation of the sound conditions in the duct system and the ventilated rooms, including dimensioning of any

silencers in the system, is only possible on the basis of the sound power level in the fan inlet and outlet openings.

In connection with all considerations concerning sound, a sharp distinction must be made between the terms sound power level and sound pressure level.

The *sound power level* is an expression of the sound energy emitted through the fan inlet and outlet openings and forms the basis for any calculation concerning the sound conditions in the connected duct systems and in the rooms served by the fan.

The *sound pressure level* (often just called the sound level) is a measure of the sound impression perceived by the ear at a given location in the fan surroundings. It is measured using a sound meter with a microphone mounted in a specific location.

The sound pressure level depends on the fan sound power level, the distance from the fan and the silencing properties of the surroundings. When the fan sound properties are characterised

by stating a sound pressure level, it is therefore necessary also to give a precise description of the conditions under which the sound level stated occurs.

When comparing the sound properties of two fans, the sound power level must never be compared with the sound pressure level, and it is only possible to compare two sound pressure levels when the distance from the fan and the silencing in the surroundings are identical.

For a correctly constructed fan, the sound power level depends mainly on the airflow rate supplied and the total fan pressure.

The sound power level of the individual fans is shown in the graphs on pages 9-13 and is stated in dB with a reference value of 10^{-12} W and applies within the normal fan working range with a tolerance of ± 5 dB. If the sound power level needs to be divided into octave values, the sound power level in the different octave bands is determined by deducting the correction values in the table from the total sound power level found.

For CNA and CNB, the correction values depend on the blade frequency.

$$z \times \frac{n}{60}, \text{ where}$$

z = number of blades and
n = fan speed in RPM.

For CNA and CNB the number of blades is 12.

CORRECTION VALUES

| | Blade frequency [Hz] | Octave band [Hz] | | | | | | |
|------------------|----------------------|------------------|-----|-----|----|----|----|----|
| | | 63 | 125 | 500 | 1k | 2k | 4k | 8k |
| Correction value | 90-180 | 7 | 4 | 12 | 17 | 22 | 27 | 32 |
| | 180-360 | 11 | 7 | 7 | 12 | 17 | 22 | 27 |
| | 360-710 | 13 | 11 | 4 | 7 | 12 | 17 | 22 |
| | 710-1400 | 15 | 13 | 6 | 4 | 7 | 12 | 18 |

Example: A centrifugal fan type CNA 315 has an output of 0.6 m³/s at 300 Pa and 1400 RPM.

Blade frequency: $12 \times 1400/60 = 280$ Hz.

As the graph on page 10 shows, the total sound power level is 84 dB.

The correction value for 250 Hz is 4 dB.

The sound power level for this octave band is thus: 84 dB - 4 dB = 80 dB

The full octave analysis is shown in the table below.

| | Octave band [Hz] | | | | | | |
|------------------------|------------------|-----|-----|----|----|----|----|
| | 63 | 125 | 500 | 1k | 2k | 4k | 8k |
| Sound power level [dB] | 73 | 77 | 77 | 72 | 67 | 62 | 57 |

REGULATION OF AIRFLOW RATE

Depending on the operating requirements, the fan capacity can be regulated in several ways.

- Changing poles between 2 fixed RPMs in the ratio 3:2 (motor with 2 separate windings) or 2:1 (Dahlander winding motor)
- Frequency regulation
- A combination of the above

CHANGING POLES

In connection with time-related variations in the airflow rate demand (for example, night-time and daytime operation), it is recommended that the fan be fitted with a change-pole motor. When the fan is changed to a different RPM, the fan efficiency is unchanged. The change can be controlled by a timer. If other operating points are required than can be achieved by changing poles, other regulation methods must be used.

FREQUENCY REGULATION

The fan efficiency remains virtually unchanged throughout the regulation range and no sound is generated during the regulation.

QUALITY AND SERVICE



REST ASSURED

The Novenco CNA-CNB centrifugal fans are produced in accordance with Novenco's well-known quality standards. Novenco Building & Industry A/S is ISO certified and all fans are inspected and tested.

The fans are offered with options for technical guidance on installation, test of function and training of personnel.

WARRANTY

Novenco provides according to law a standard 12 months warranty from the

product is sent from the factory. The warranty covers materials and manufacturing defects. Wear parts are not covered.

Extended warranty can be agreed upon.

IMPORTANT

This document is provided 'as is'. Novenco Building & Industry A/S reserves the right to changes without further notice due to continuous product development.

Some pictures in the catalogue show products with accessories fitted.

The fans are designed for continuous operation. The following kinds of operation may cause fatigue break in the impellers and endanger people.

- Operation in stall area
- Operation with pulsating counter pressure – called pump mode
- Operation with exceedingly starts and steps

If in doubt, Novenco should be contacted to assess the suitability of the fans.

Copyright (c) 1998 - 2017,
Novenco Building & Industry A/S.
All rights are reserved.

PATENTS AND TRADEMARKS

Novenco®, ZerAx®, 诺文科, 诺万科 and are 诺克
NOVENCO registered trademarks of Novenco A/S.

AirBox™ and NovAx™ are trademarks of
Novenco Building & Industry A/S.

Other trademarks appearing in this document
are the property of their respective owners.

QUALITY AND ENVIRONMENT

Novenco Building & Industry A/S is certified in
accordance with ISO 9001 and 14001.



All Novenco Building & Industry's products are
designed, developed and manufactured in
Denmark.

