

OUTER FRAME

Please Note:

Genesis frames are usually fitted behind brickwork (in check) which leaves approximately half of the frame (35mm) visible when installed.

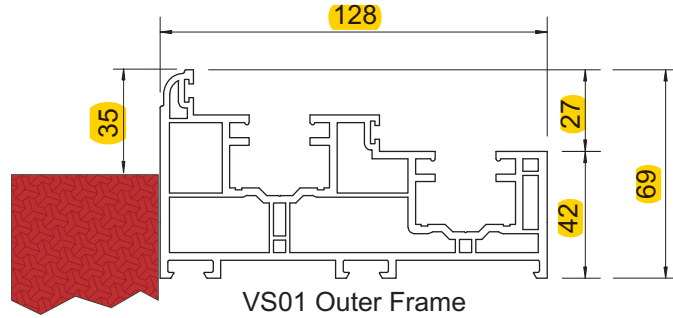

CILLS

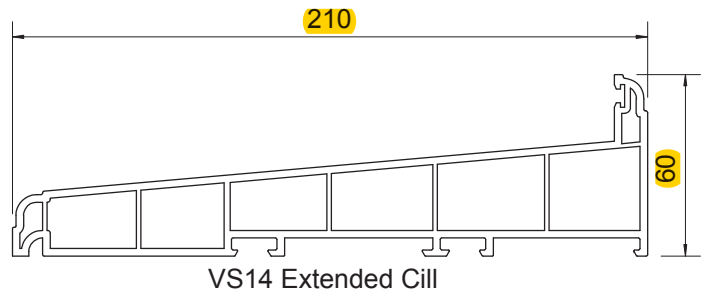
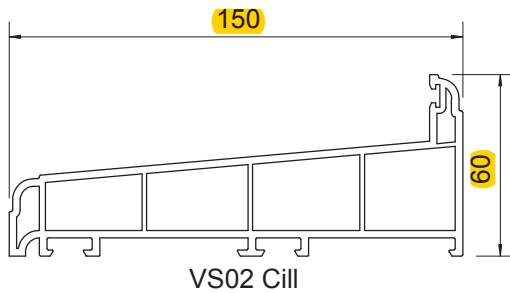

SASHES

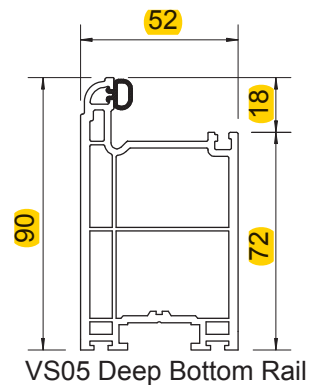
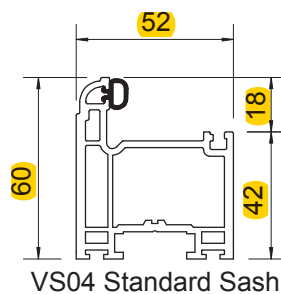
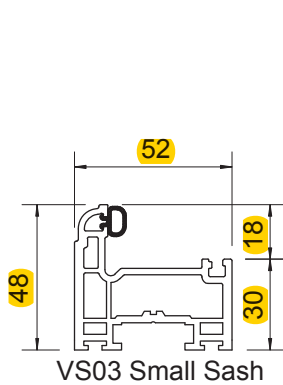

INTERLOCK & SASH STOP

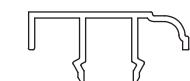
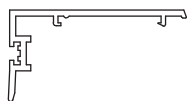

BEADS & ANCILLARIES

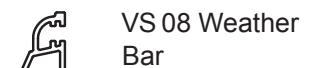
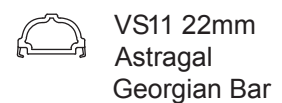
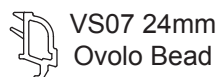
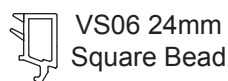

STANDARD CONFIGURATION (VERTICAL SECTION)

TYPICAL VERTICAL SLIDING WINDOW

SPECIFICATION

Small Top Sash
 Standard Bottom Sash
 Deep Bottom Rail Sash
 Co-extruded 24mm Glazing Bead
 Standard Cill
 Thermal, Steel or Aluminium Reinforcing

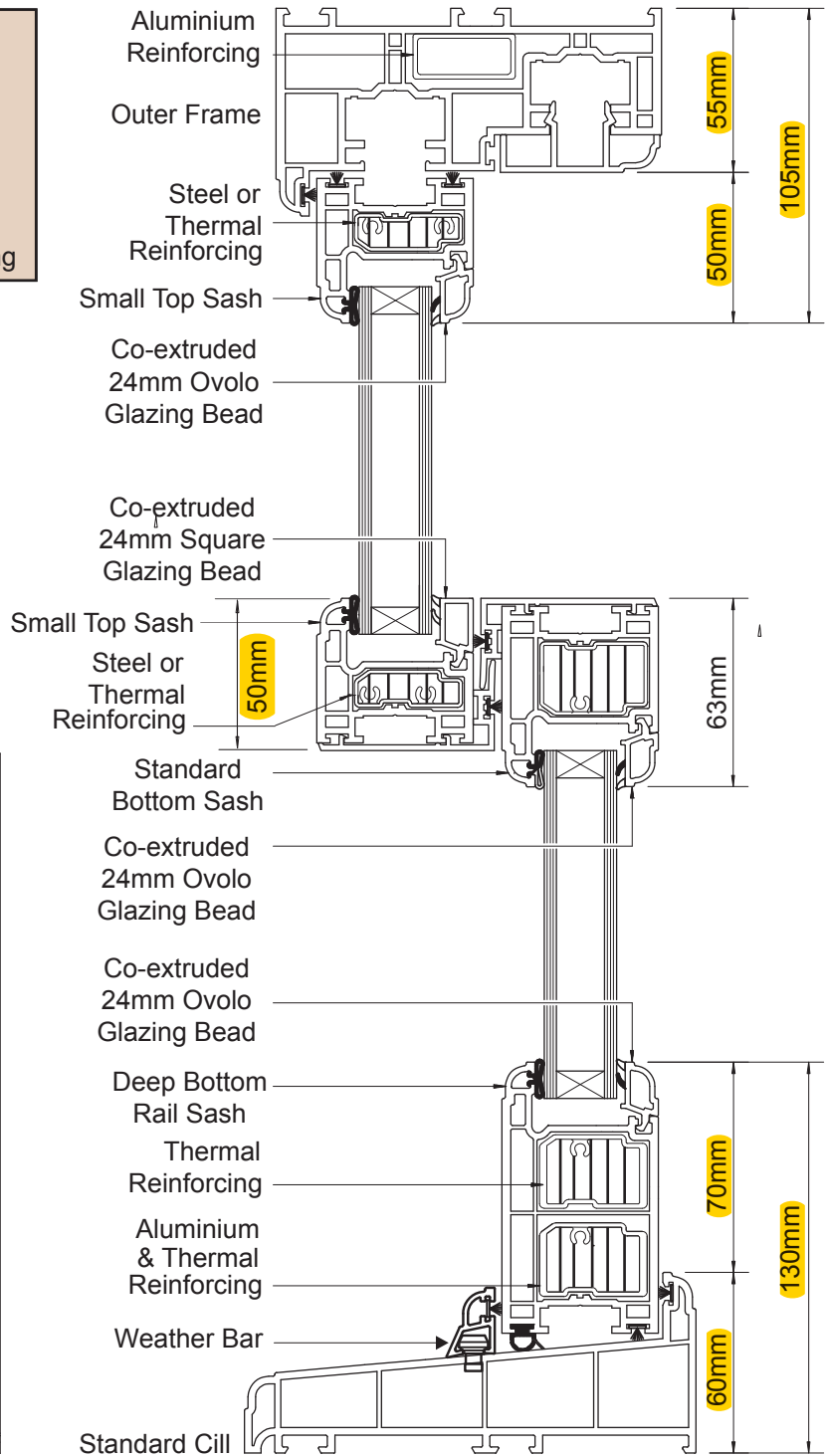
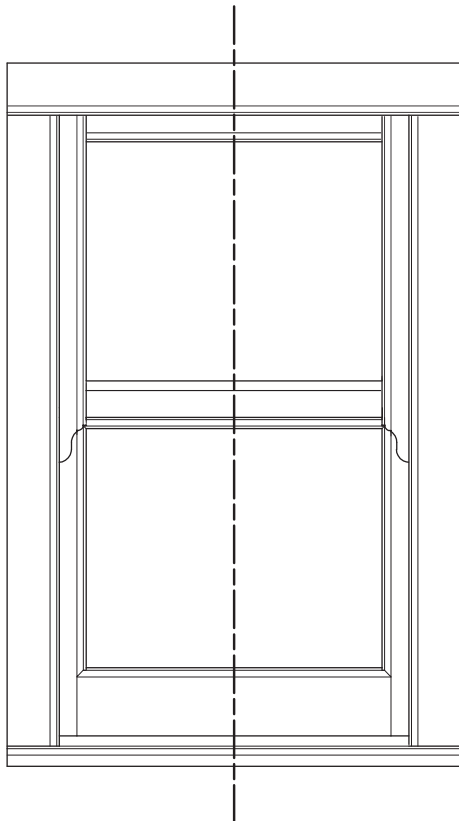

STANDARD CONFIGURATION (HORIZONTAL SECTION)

TYPICAL VERTICAL SLIDING WINDOW

SPECIFICATION

Small Top Sash
Standard Bottom Sash
Co-extruded 24mm Glazing Bead
Thermal, Steel or Aluminium Reinforcing

