



HERITAGE STATEMENT

4-6 Redenhall Road,
Harleston,
Norfolk,
IP20 9EN.

Built pre 17th century this delightful historical Listed semi-detached property is located in the centre of the village and believed to be within a conservation area.

Originally built from Wattle and daub the property has undergone significant changes over the years mainly the introduction of a mixture of outer facing Red face brick façade and rendered panels.

Timber sliding sash box type frames are located on the principal elevation which is to remain un touched by our proposal.

Recent modern changes to the rear elevation have seen the replacement of a selection of timber windows of various size and design set in numerous locations. These windows were a single glazed casement type generally used in modern replacement or new build. The more recent replacements are manufactured from hardwood & double glazed.

The roof is of interlocking tiles laid to falls with modern guttering, the property boasts a prominent chimney which forms part of this delightful historical building.

The property has undergone significant change over the years and its importance as a historical building remains uppermost.

Our proposal relates to the replacement of the existing timber doors to the rear elevation, which are not visible from the road or any neighbouring property. I feel our proposal would not have any significant impact on the area and therefore would not compromise the importance of the area. We are not setting precedence for others to follow.



Unit 12-13, Basey Road
Rackheath Industrial Estate, Rackheath
NR13 6PZ



Tel: 0800 292 2821 Email: Sales@euro-glaze.com

1 of 3



1580 NORMAN
18-5-21

GRADE II LISTING

2 NO BESPOKE HARDWOOD DOORS & FRAMES.

ANTIQUE BLACK FURNITURE; HORIZONTAL MORTICE SASH
LOCKS, RING PULL LATCH HANDLES, 2X BOLTS TO EACH (6")
DOOR, ANTIQUE BLACK ESCUTCHEON PLATES (COVERED OUTSIDE) &
30 DOOR STUDS LEFT LOOSE. 3X BUT HINGES TO EACH DOOR.
FINISHED INT & EXT WITH SIKKENS RO.10.60T

FRAME 1 (NO6)

O/A MANUFACTURE DIMENSIONS 814 X 1770

LEFT HUNG OPEN IN (EXT VIEW)

O/A 100X50 FRAME & 150 CILL SECTIONS (100mm HOLES), INCL WEATHER BAR.

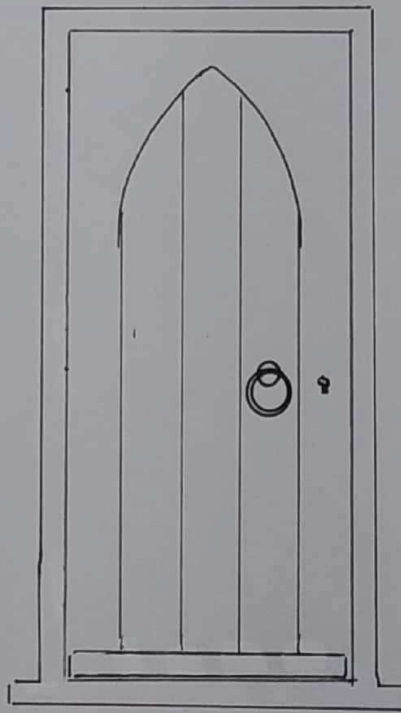

Unit 12-13, Basey Road
Rackheath Industrial Estate, Rackheath
NR13 6PZ

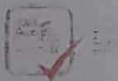

Tel: 0800 292 2821 Email: Sales@euro-glaze.com



1580 NORMAN
18-5-21

2 of 3
GRADE II LISTED

ADDITIONAL LOOSE TRIMS PRE-FINISHED, ALSO IN SIKKENS
RO. 10. 60T;

10 NO 28X8X 1900mm SINGLE EDGE FILLET



1 NO 45X8X 1900

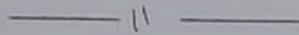

1 NO 120X20X 1005

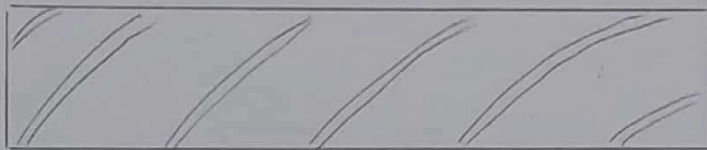

FRAME 2 (NO4)

O/A MANUFACTURE DIMENSIONS 878 X 1735

LEFT HUNG OPEN OUT (EXT VIEW)

O/A 130 X 70mm FRAME, NO PROJECTION CILL, INCL WEATHER BAR.

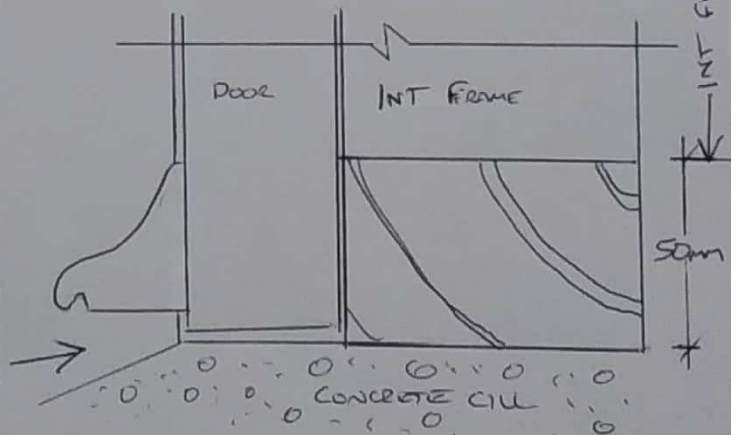
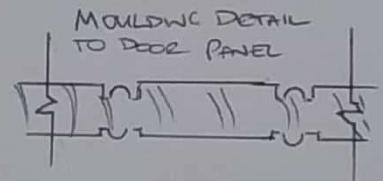

Unit 12-13, Basey Road
Rackheath Industrial Estate, Rackheath
NR13 6PZ



Tel: 0800 292 2821 Email: Sales@euro-glaze.com

3 of 3

GRADE II LISTED



1580 NORMAN
18-5-21

OVER POOL CANOPY TO FRAME 1

ALSO PRE-FINISHED WITH SIKKENS RO.10.60 T

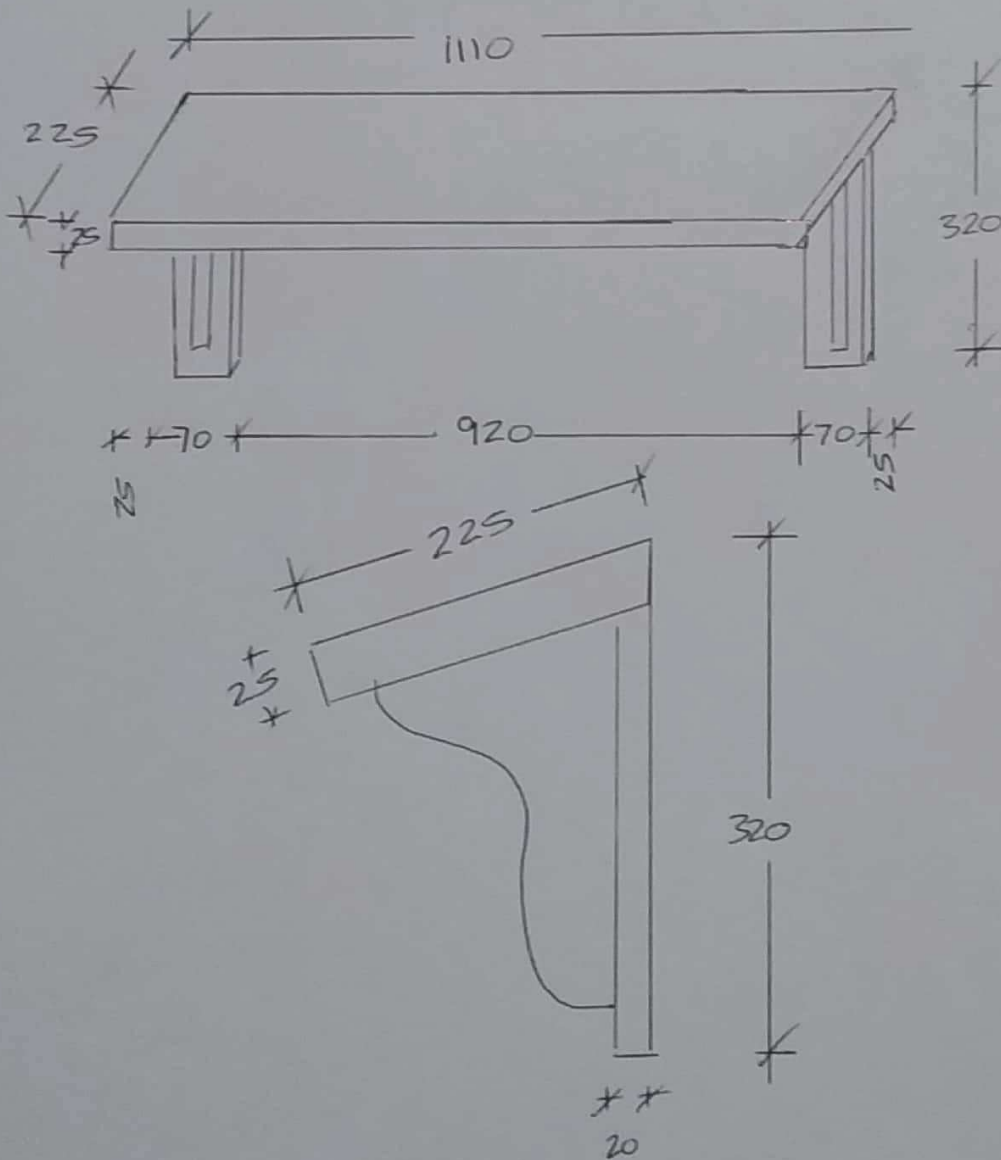

Unit 12-13, Basey Road
Rackheath Industrial Estate, Rackheath
NR13 6PZ



Tel: 0800 292 2821 Email: Sales@euro-glaze.com