

**DOOR CONSTRUCTION NOTES:**

Site dimensions must be taken prior to manufacture. Provide joinery rods for approval prior to fabrication.  
 Allow for supply and fixing new ironmongery: Jim Laurence or to client's choice  
 Allow five lever lock & £160 supply for the handle  
 Door leaves are to be manufactured in joinery grade Accoya to section sizes illustrated on the drawings.  
 All surfaces are to be prepared, primed using Graphenstone four 2 four and finished with Graphenstone mid sheen  
 All weather seals are to joiner's choice but must go all around the frame and be black or brown.  
 Joiner is to supply & fit all ironmongery to ensure it fits  
 and check dimensions of ironmongery fitted.  
 Joiner is to select and size chosen No. hinges as required for the opening element and weight.  
 Hinges to be black if possible  
 Door thresholds to have stone sill  
 All seal neaters, boards/rod secured down  
 All doors to have gips around frame and sills  
 Glazing:  
 Slim double glazed units manufactured by Histoglass (they have all three parts)  
 4mm thick toughened Clear float outer pane,  
 4mm gas filled cavity, with white aluminium spacer bar. (Ibc depending on door pane)  
 4mm thick toughened Ultra Clear Low E glass inner pane.  
 Double glazed units to be installed on a non hardening butyl compound, secured with glazing springs and finished with putty, all in accordance with the glazing manufacturer's recommendations.

**Note: Door size is approximate and openings must be measured on site prior to being made**

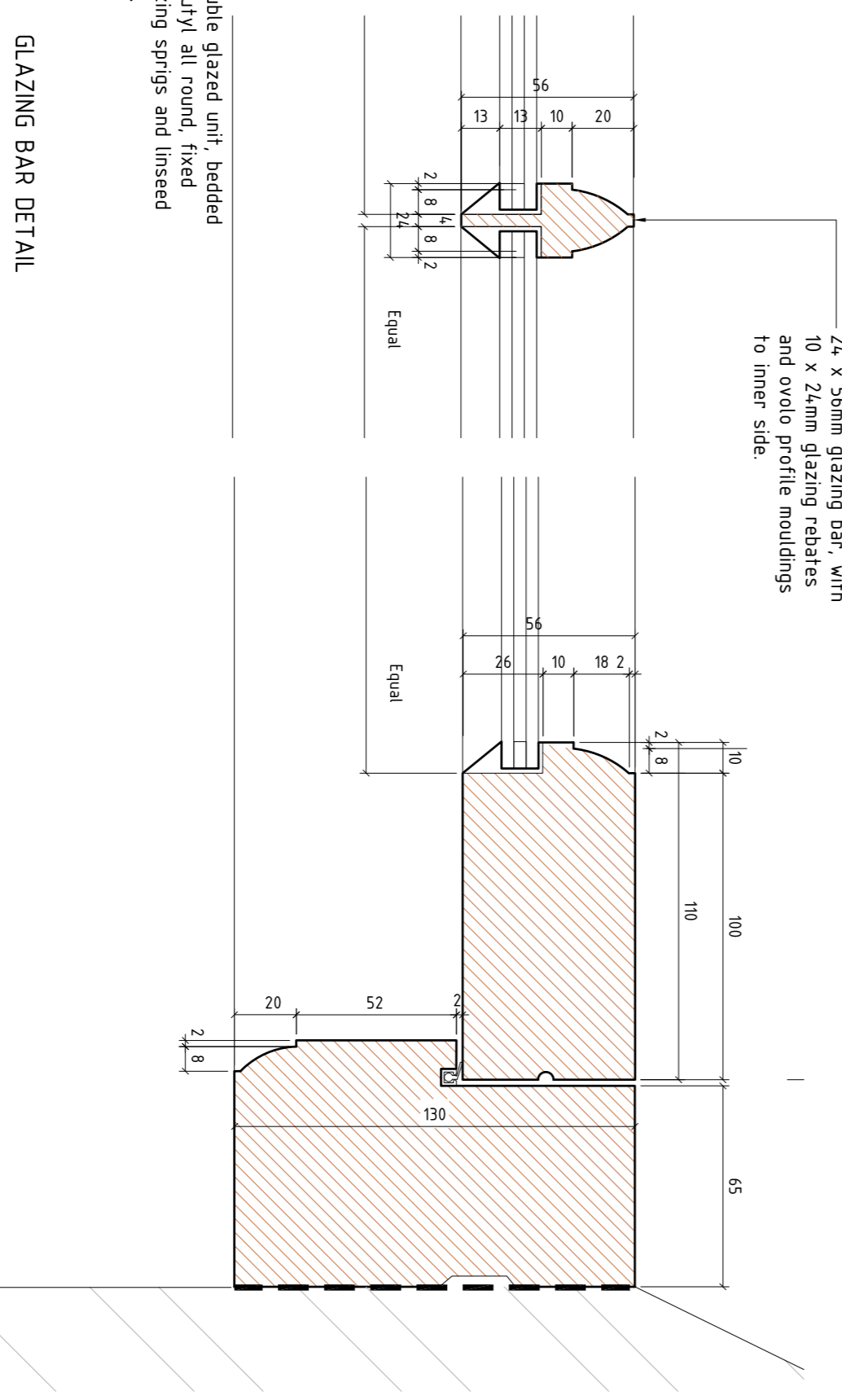
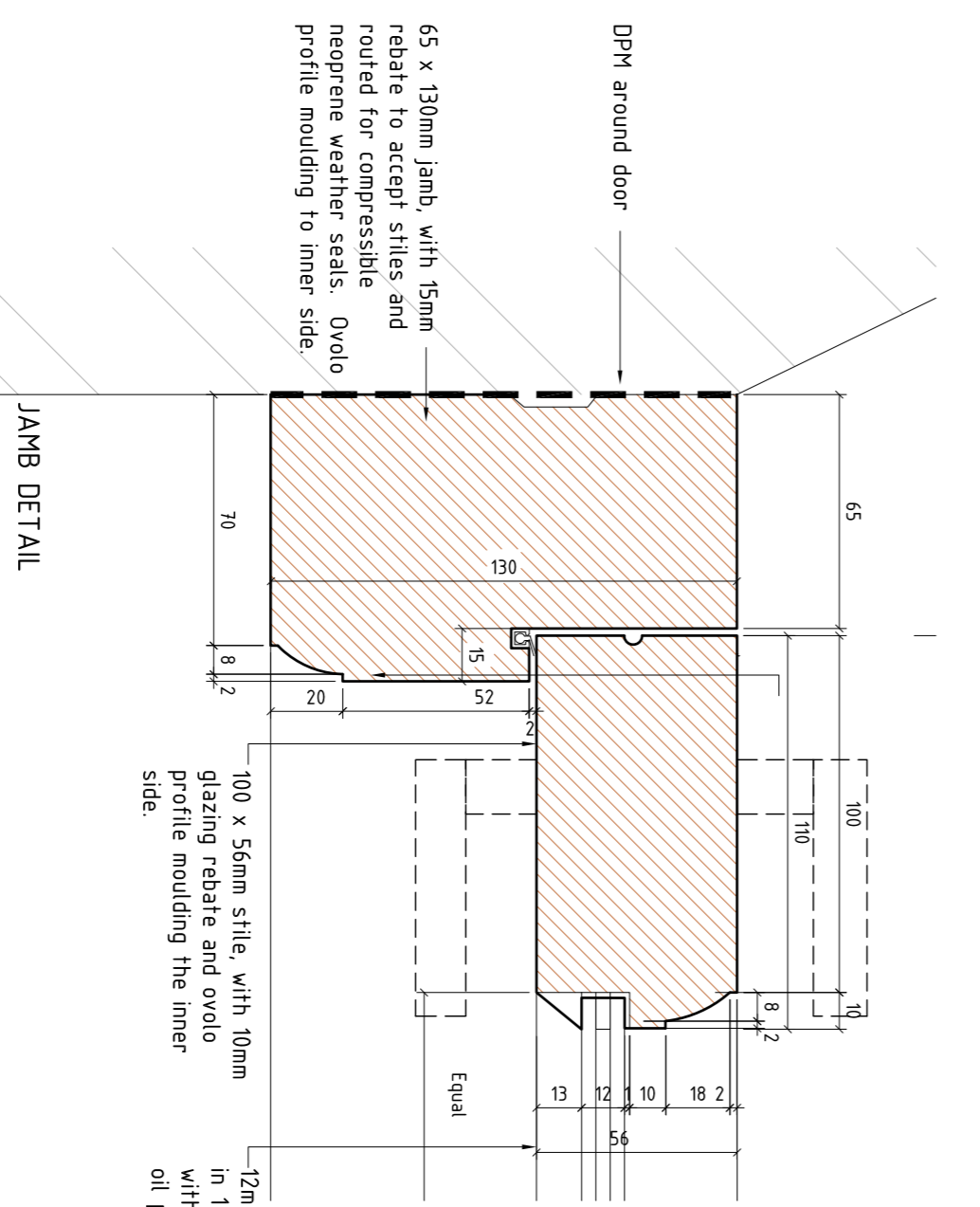
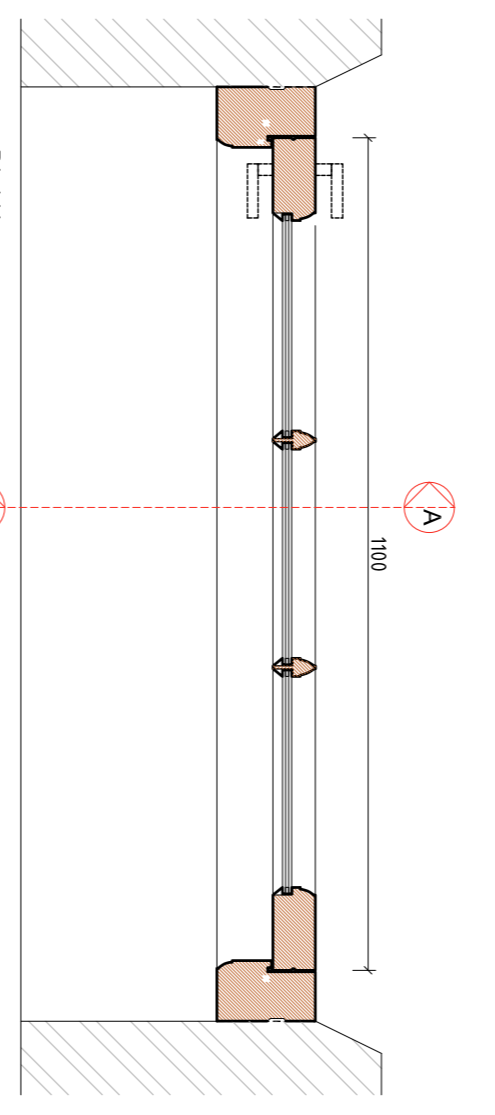

**GENERAL:**  
 All planning and building consent conditions must be obtained by the Local Authority prior to the commencement of the works.  
 Adhere to all planning/listed building consent conditions for the duration of the works.  
 All construction must comply to the current Building Regulations, whether indicated on the drawings or otherwise. The Contractor is to request staged inspections by the Building Control Officer and request a Completion Certificate at the end of the works.  
 All dimensions are to be verified on site prior to the commencement of the works. All dimensions before work commences. Do not scale from the drawings.  
 All materials and fixtures/ fittings are to be installed in accordance with the manufacturer's recommendations.

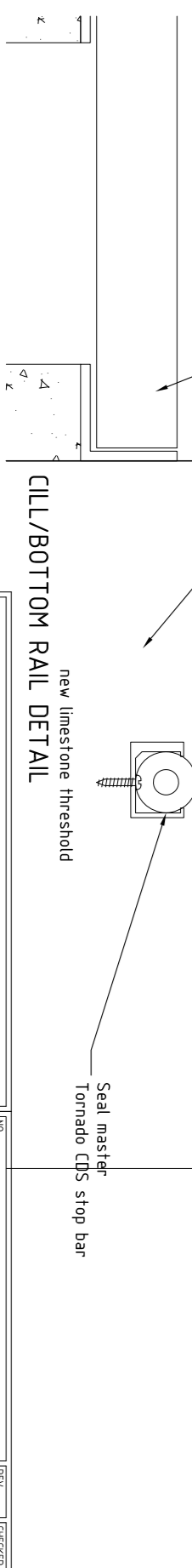
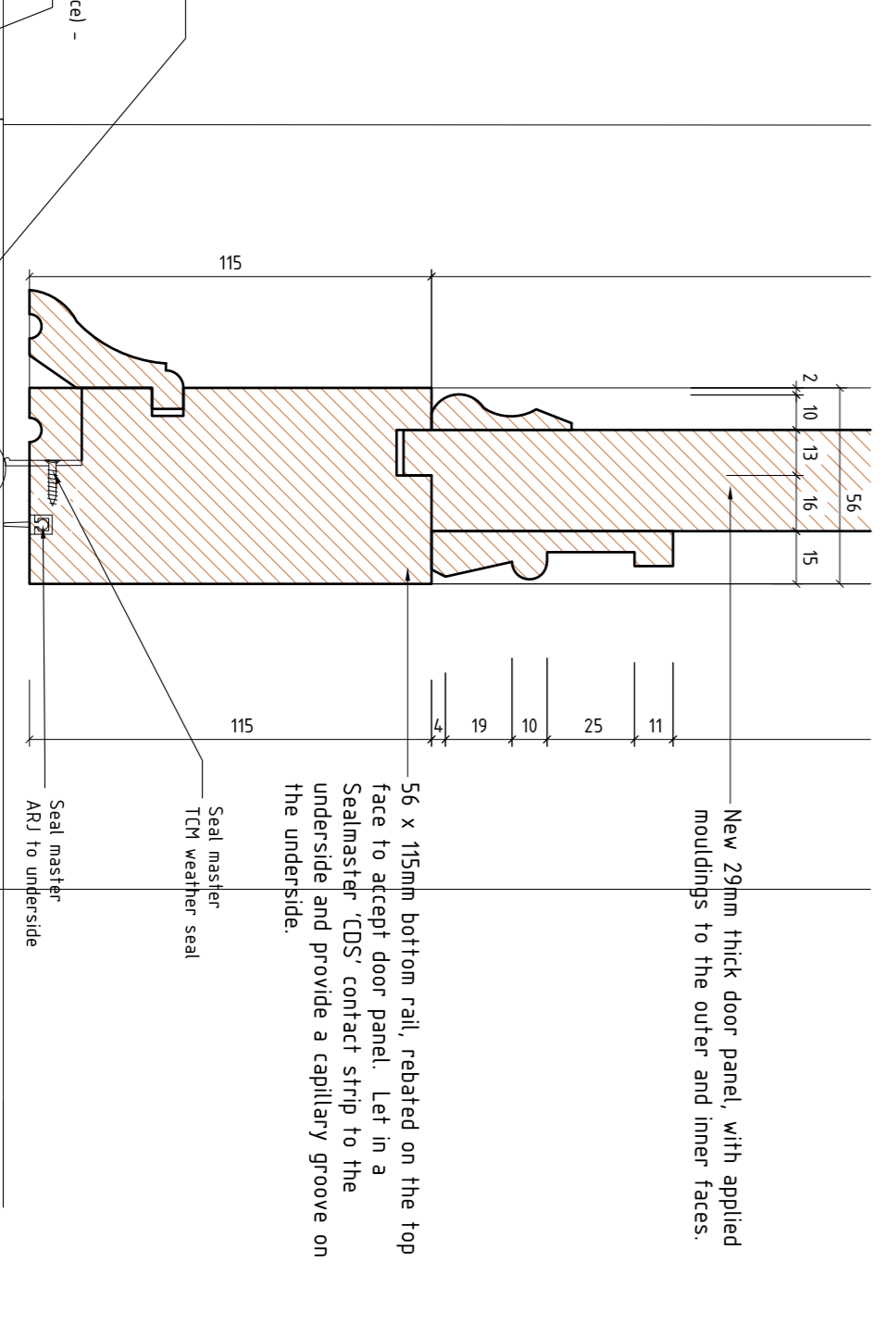
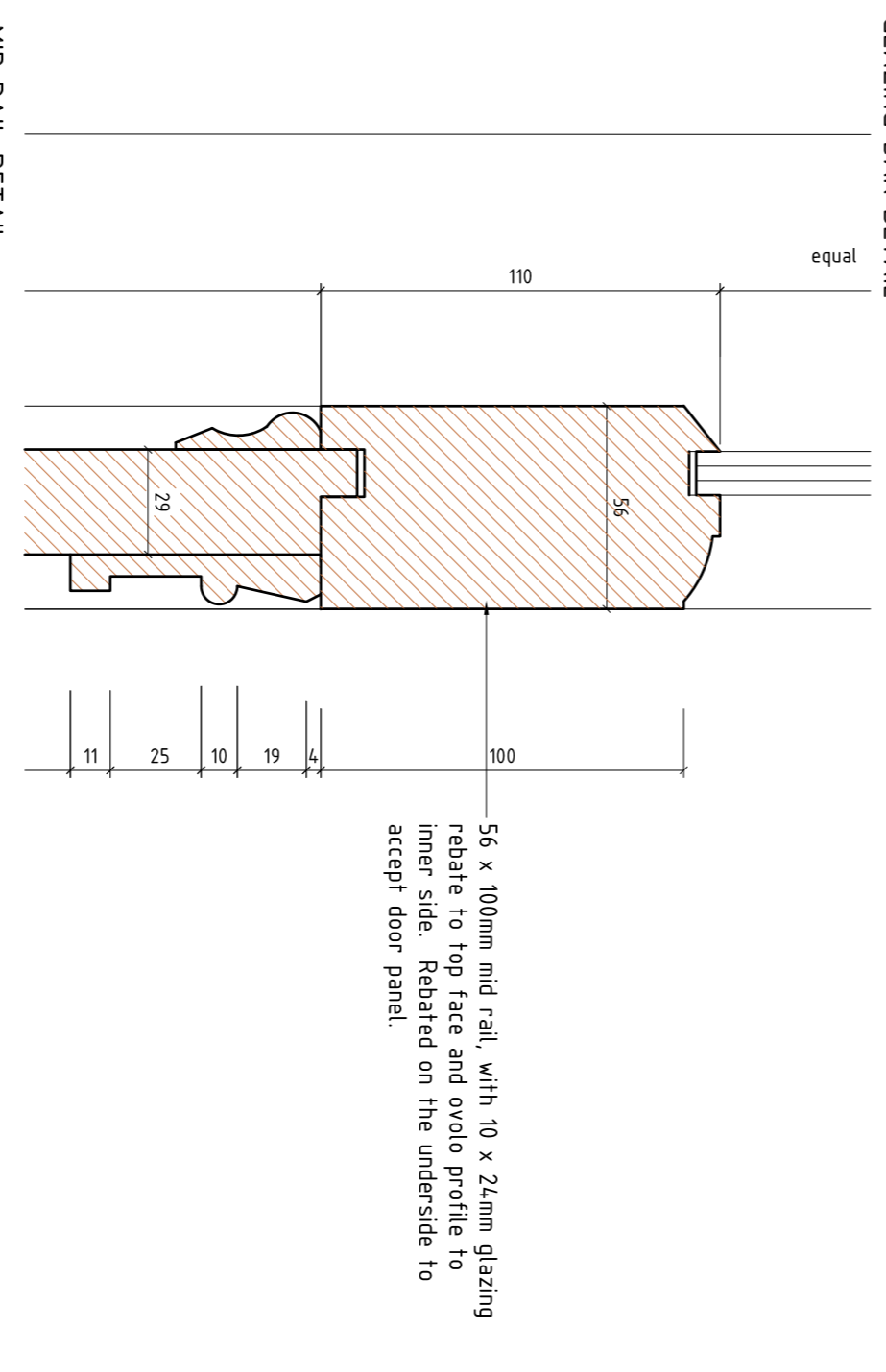
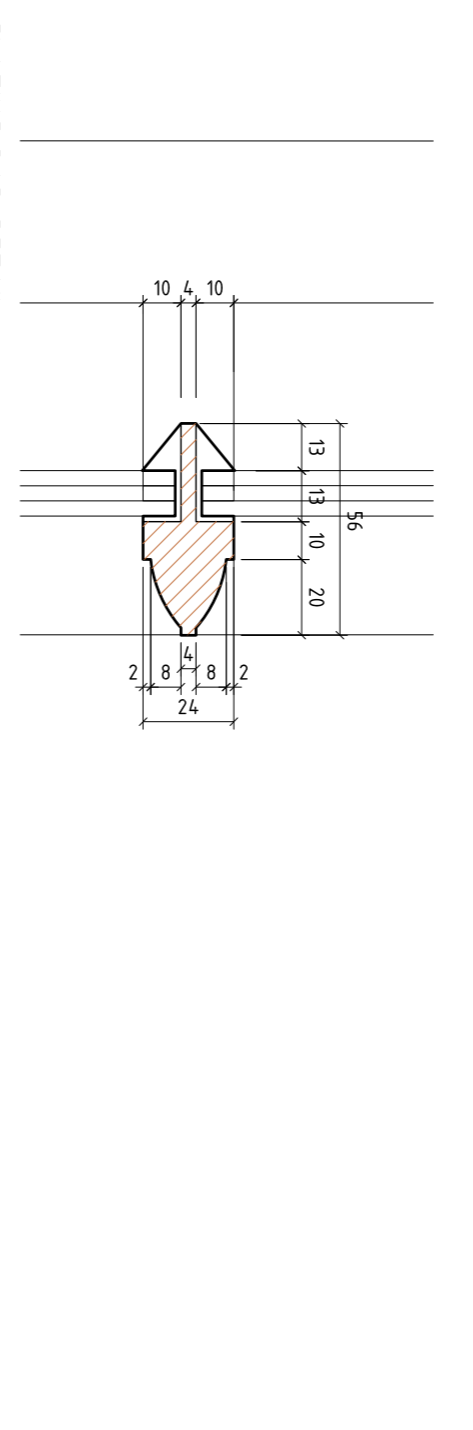
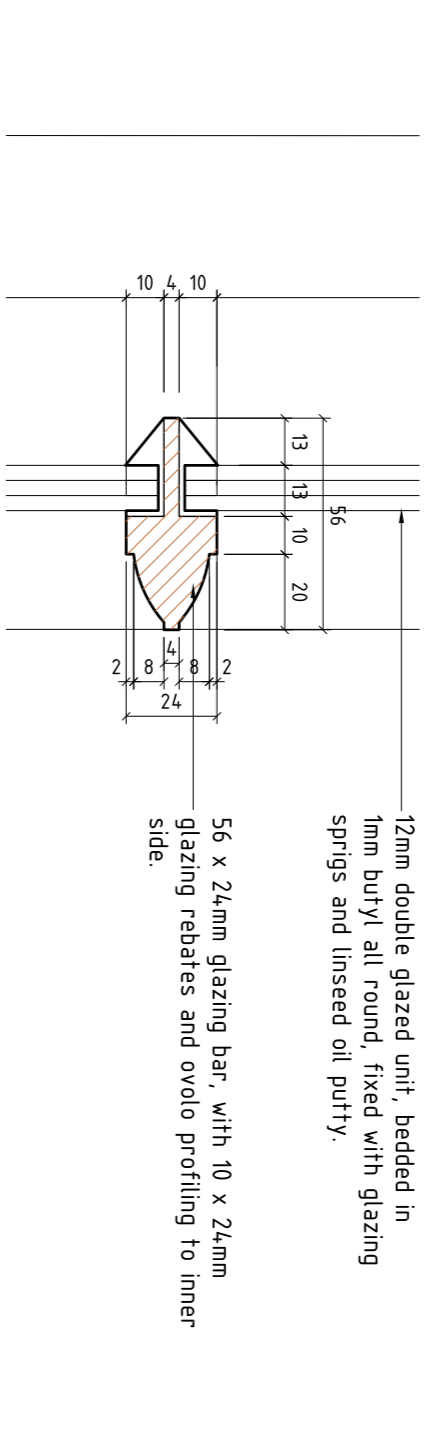
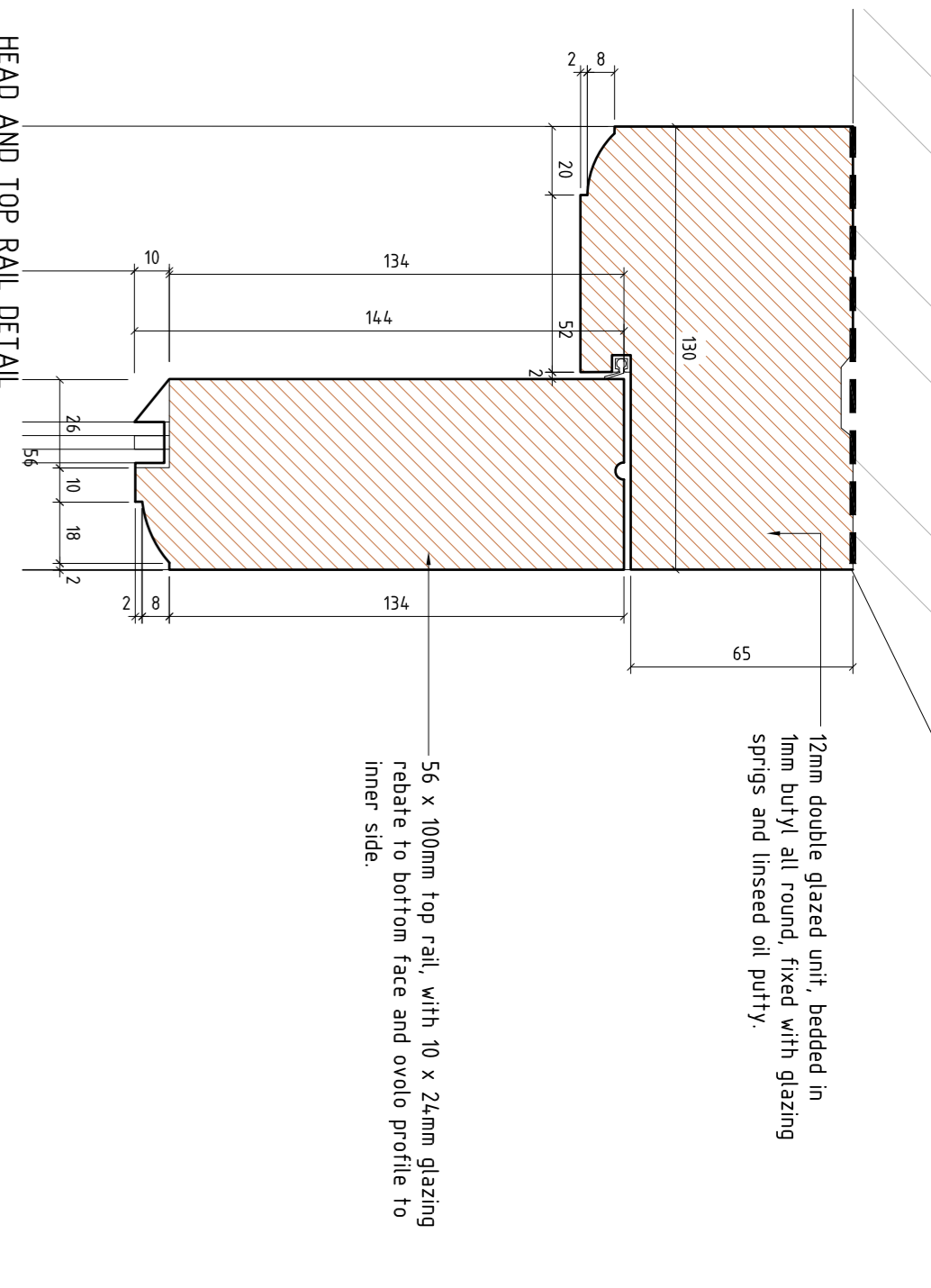

**comment & pricing issue**

ENTRANCE DOOR JOINERY DETAILS		DATE	BY
FOR MR & MRS SCOTT		19 38 / WD / 31 13	A ST
SHEILEY HALL		SCALE	1:10
B2 700		DATE	21
AY PILLSBURY THOMAS ARCHITECTS		PROJECT NO.	21
100, THE SQUARE, SOUTHAMPTON, SOUTHAMPTON, SOUTHAMPTON, SOUTHAMPTON, SOUTHAMPTON		PROJECT NAME	21
01703 757575		PROJECT ADDRESS	21
www.pillsburythomas.com		PROJECT CONTACT	21