

27 Tilney Road Southall UB2 5LT - Proposed single storey extension

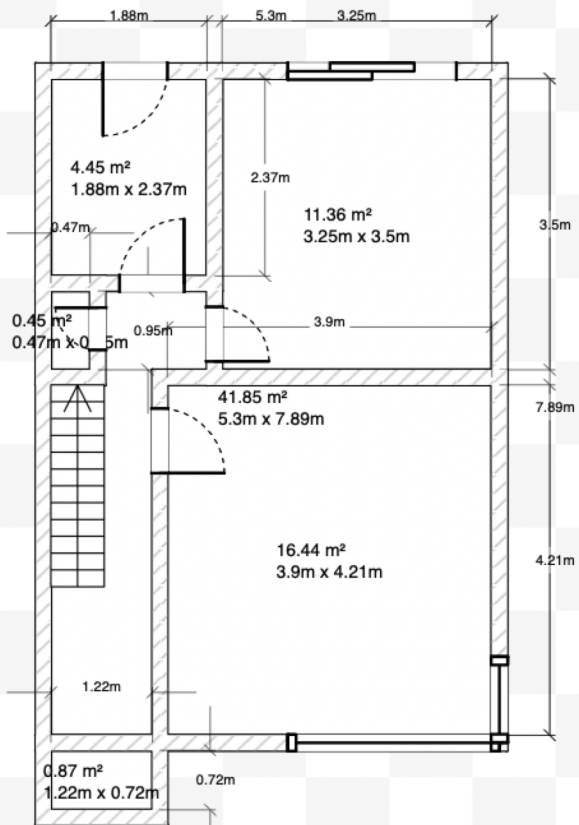

Existing Plan - Ground Floor

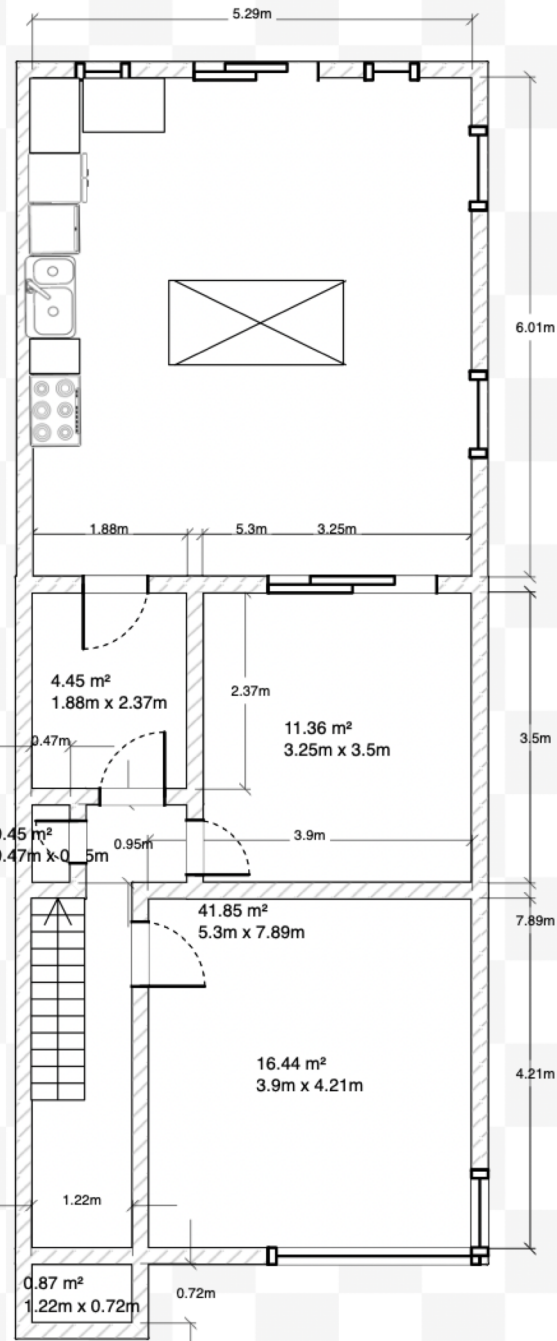

Proposed Plan - Ground Floor

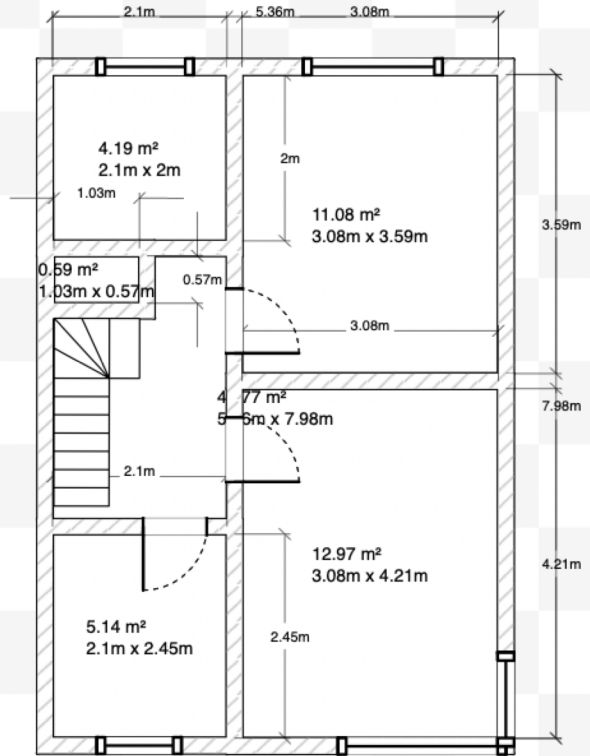

Existing Plan - First Floor

Proposed Extension