







PLEASE NOTE
1. All dimensions to be verified on site.
2. All dimensions are in millimetres.
3. No work shall commence until all approvals and agreements have been obtained. These include, Planning, Building Regulations, Thames Water and Party Wall.
4. The Copyright of this drawing belongs to Projection Architects Ltd.



- NOTES:**
-  EXISTING WALL
 -  DEMOLISHED WALL
 -  PROPOSED NEW CAVITY WALL
 -  PROPOSED STUD WALL
 -  PROPOSED INTERNAL BLOCK WALL
 -  PROPOSED DORMER WALL
 -  BOUNDARY LINE

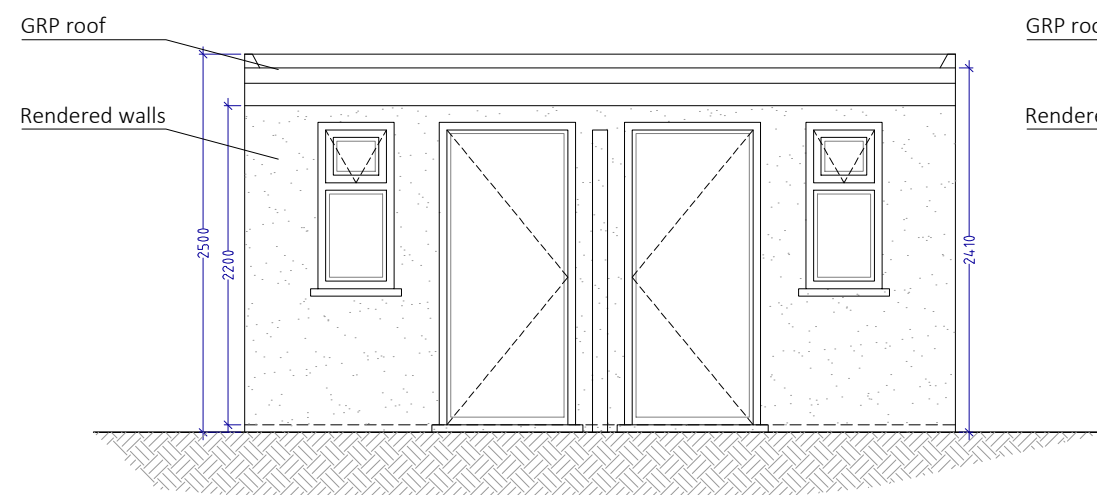

PROPOSED FRONT ELEVATION

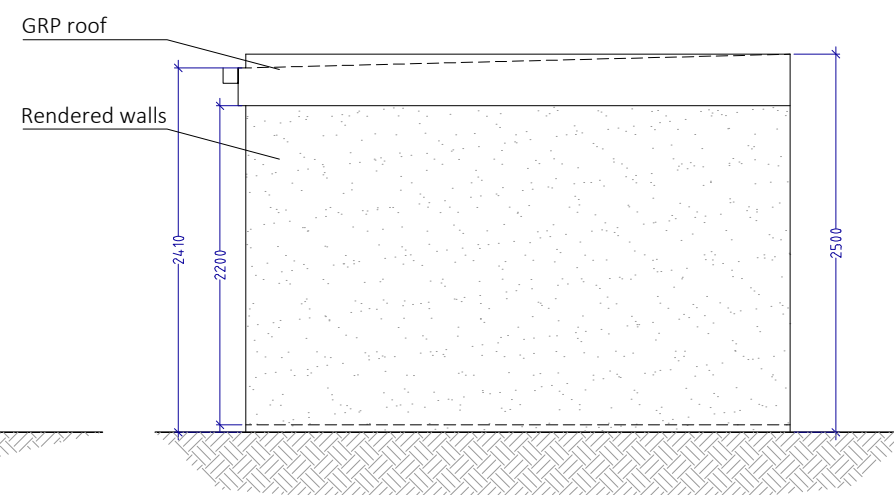

PROPOSED WEST SIDE ELEVATION

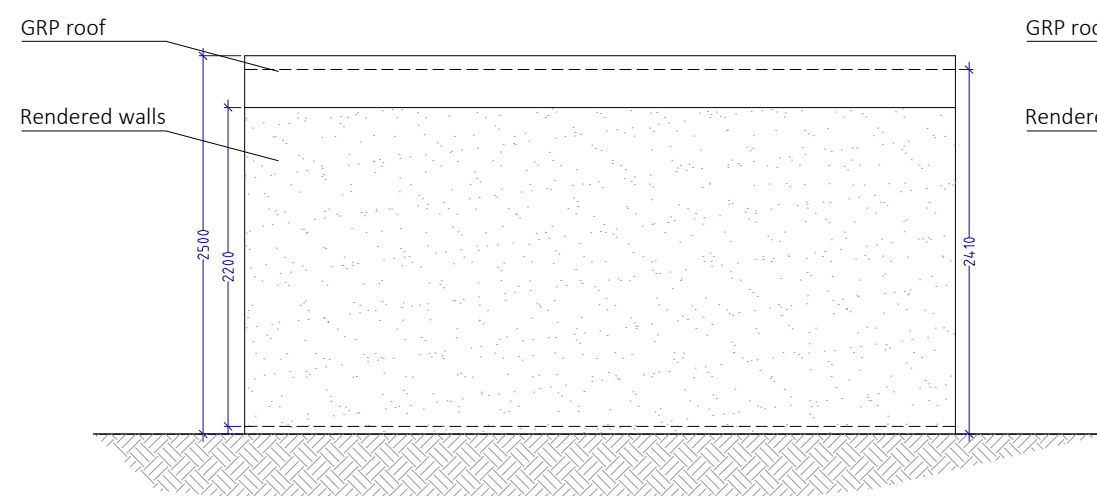

PROPOSED REAR ELEVATION

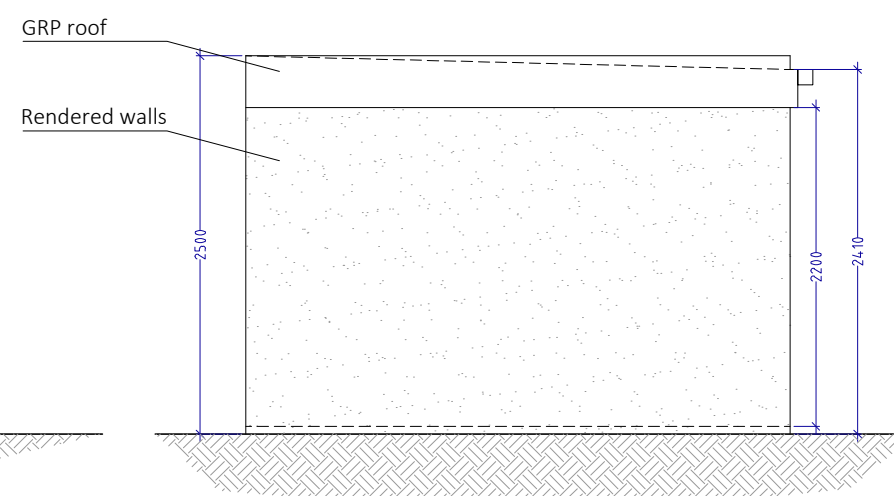

PROPOSED EAST SIDE ELEVATION

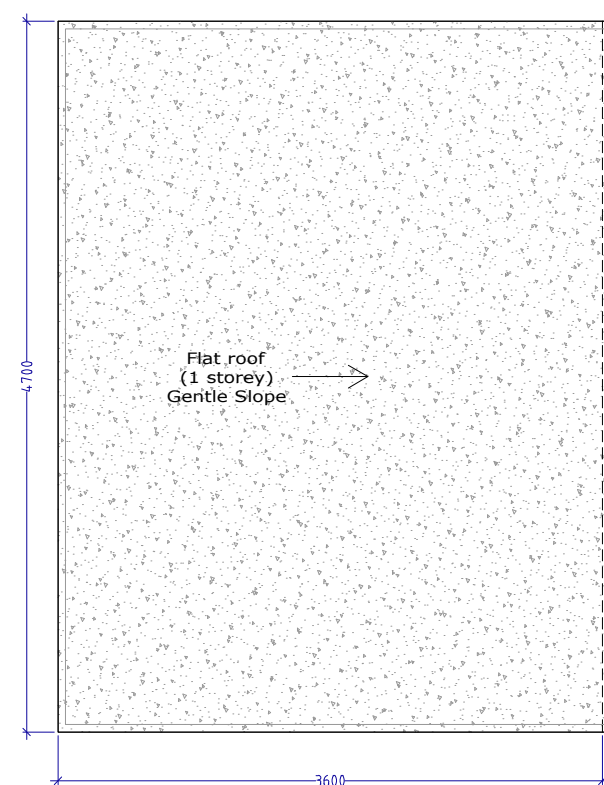
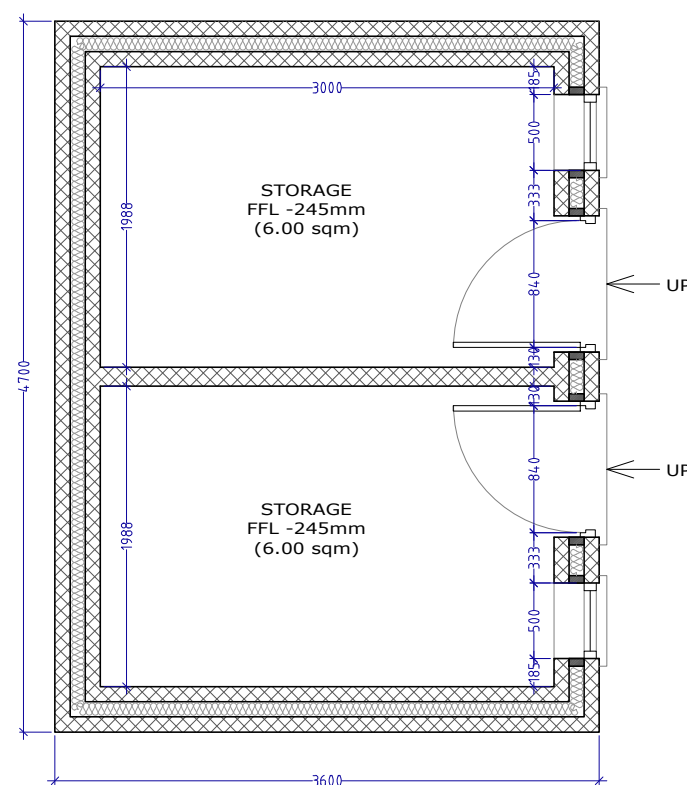

PROJECT
Outbuilding

ADDRESS
21A & 21 B Falkland Avenue
LONDON
N3 1QR

CLIENT
MR. ARTAN RICA

TITLE
Proposed Outbuilding

DATE
28/06/2021

PROJECT NUM:
P-21.045.1

SCALE
1/50 (@ A3)

DRAWING NUM:
A-06

REV. A STATUS PL