

1 Proposed Elevation
1:20 @ A1

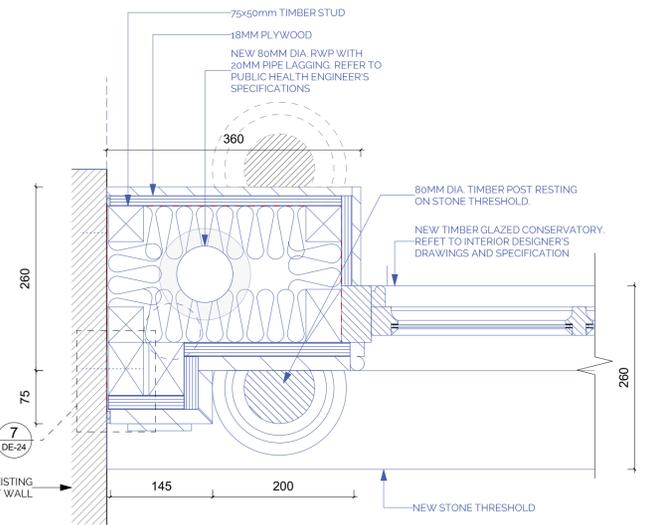

6 Junction Detail
1:5 @ A1

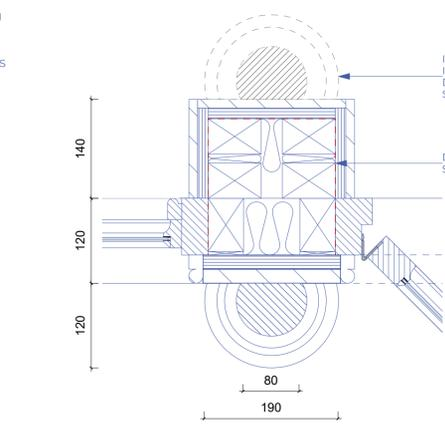

7 Detail 7
1:5 @ A1

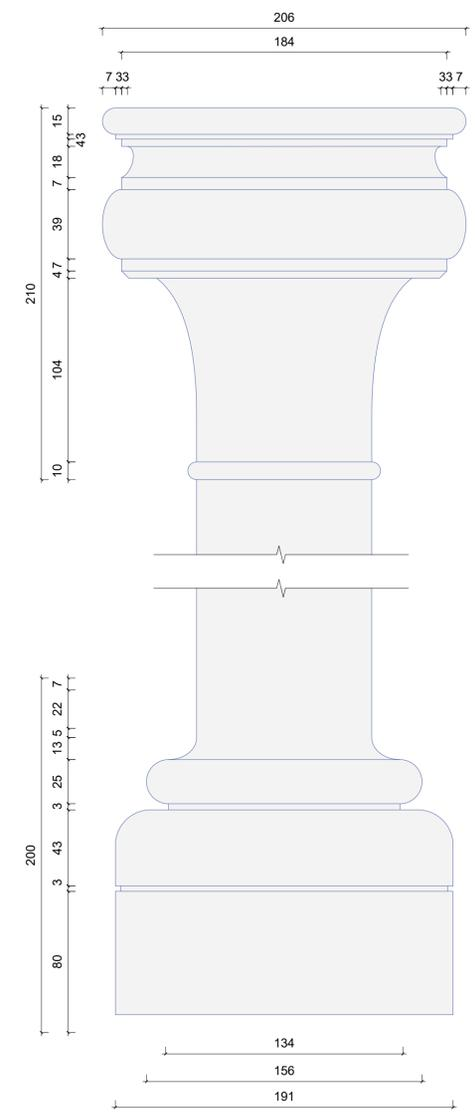

8 Timber post profile
1:2 @ A1

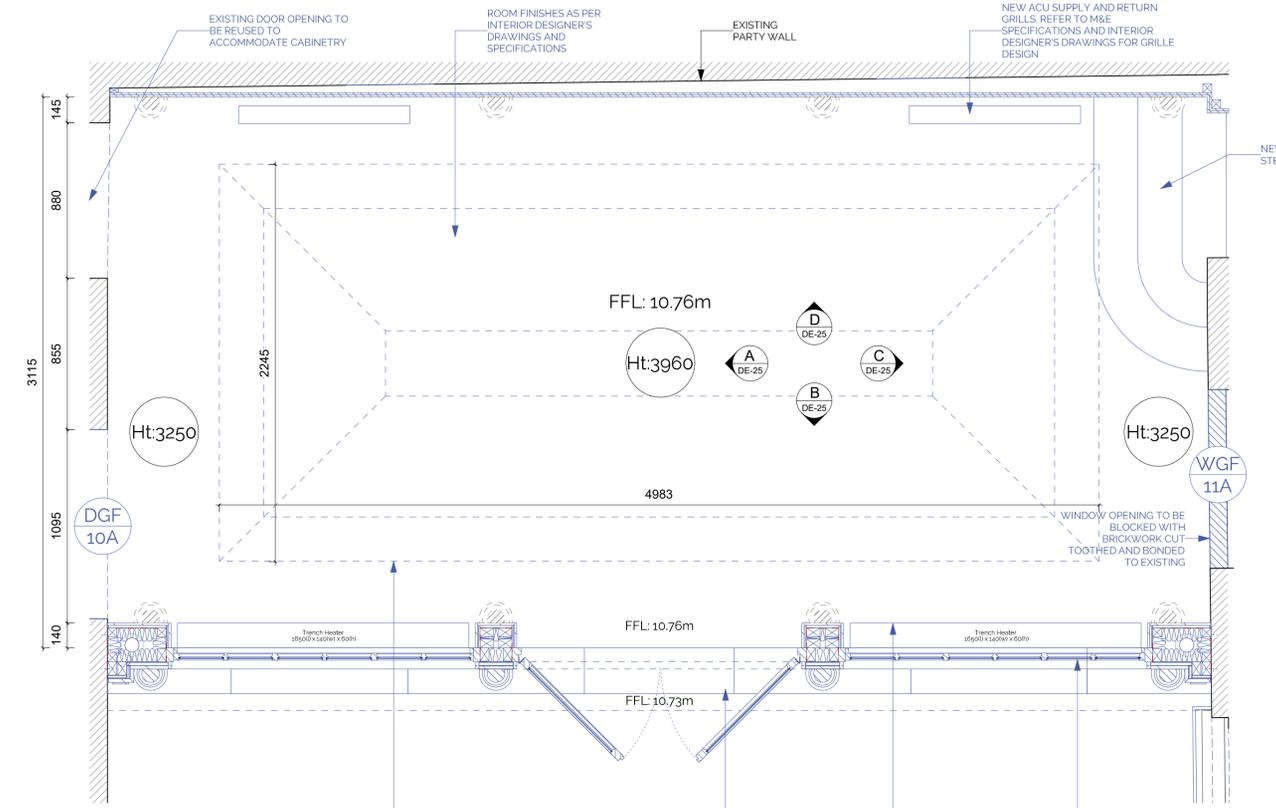

2 Proposed Plan
1:20 @ A1

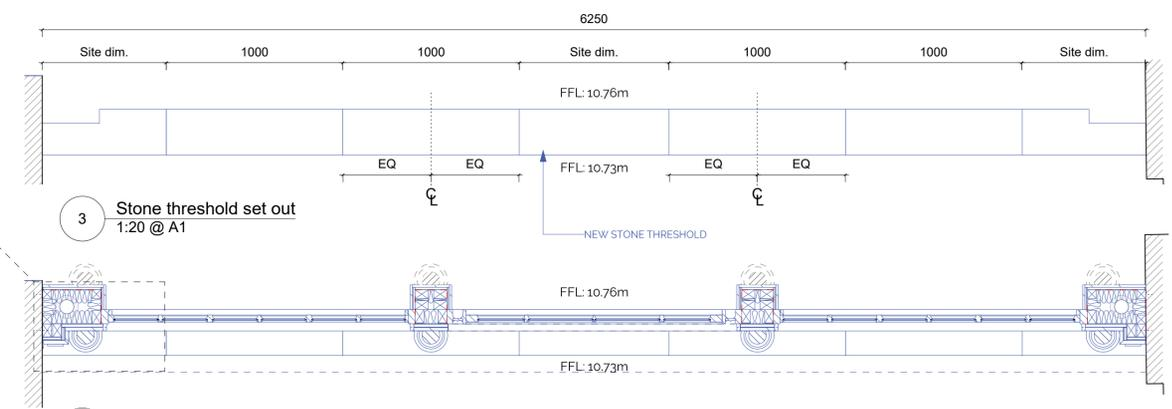

3 Stone threshold set out
1:20 @ A1

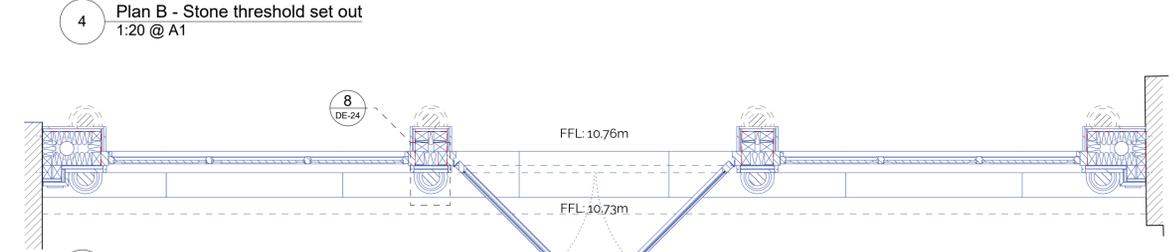

4 Plan B - Stone threshold set out
1:20 @ A1

5 Plan C - Section through bottom panels
1:20 @ A1

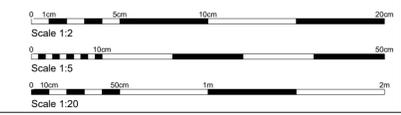

DO NOT SCALE OFF THIS DRAWING. USE FIGURED DIMENSIONS ONLY OR CONSULT THE ARCHITECT. ALL DIMENSIONS TO BE CHECKED ON SITE BY CONTRACTOR. ARCHITECT TO BE INFORMED OF ANY VARIATIONS THAT MAY OCCUR BEFORE COMMENCEMENT OF WORK.

THIS DRAWING IS FOR AESTHETIC DESIGN INFORMATION PURPOSES ONLY & DOES NOT CONTAIN ANY INFORMATION FOR CONSTRUCTION, PERMITS OR COMPLIANCE TO BUILDING REGULATIONS.

KEY:
SILL: - INTERNAL WINDOW SILL HEIGHT
HEAD: - INTERNAL WINDOW HEAD HEIGHT
FFL: - FINISHED FLOOR LEVEL
HT: - FLOOR TO CEILING HEIGHT

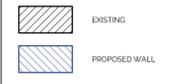

ALL DIMENSIONS TO BE CHECKED ON SITE

CONTRACTOR TO SUBMIT SHOP DRAWINGS FOR ARCHITECT'S APPROVAL PRIOR TO MANUFACTURE.

TENDER ISSUE

T1 11/02/2021 TENDER ISSUE

REV.	DATE	DESCRIPTION
------	------	-------------

10 BELGRAVE SQUARE
LONDON

GF-10 CONSERVATORY
PLAN AND EXTERNAL ELEVATION

DRNG No	SCALE	DATE
DE-22 T1	1:20 @ A1	FEB 2021



5 ST JAMES'S SQUARE
LONDON SW1Y 4JU
T 020 7451 0955 mail@stanhopegate.co.uk
www.stanhopegatearchitecture.com