

**DOUBLE GARAGE**  
**- FRONT ELEVATION**

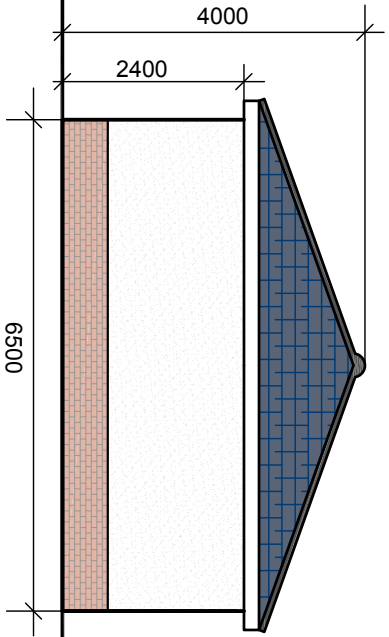

**DOUBLE GARAGE**  
**- SIDE ELEVATION**

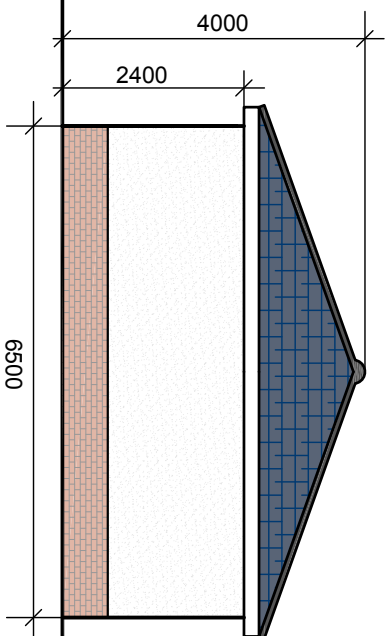

**DOUBLE GARAGE**  
**- SIDE ELEVATION**

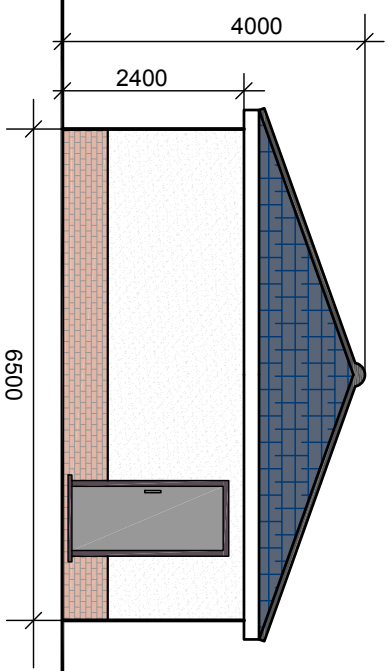

**DOUBLE GARAGE**  
**- REAR ELEVATION**

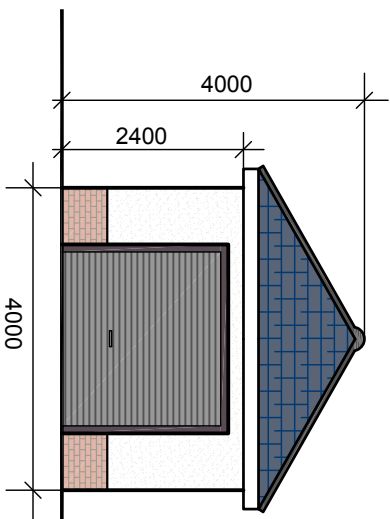

**SINGLE GARAGE**  
**- FRONT ELEVATION**

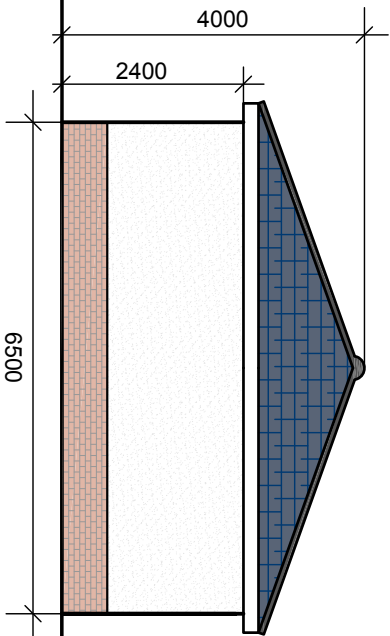

**SINGLE GARAGE**  
**- SIDE ELEVATION**

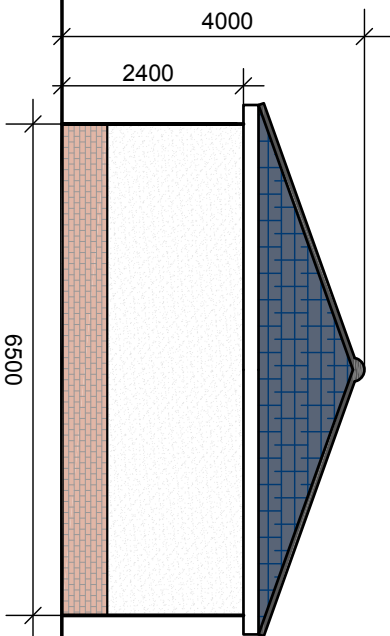

**SINGLE GARAGE**  
**- SIDE ELEVATION**

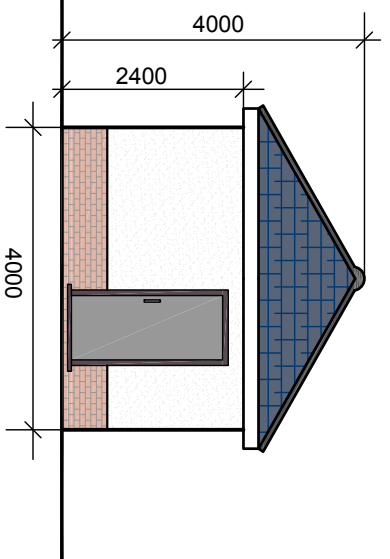

**SINGLE GARAGE**  
**- REAR ELEVATION**

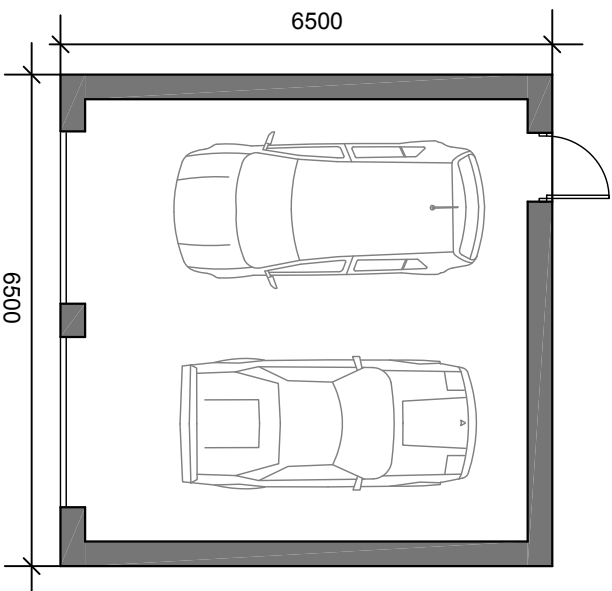

**FLOORPLAN**  
**- DETACHED DOUBLE GARAGE**

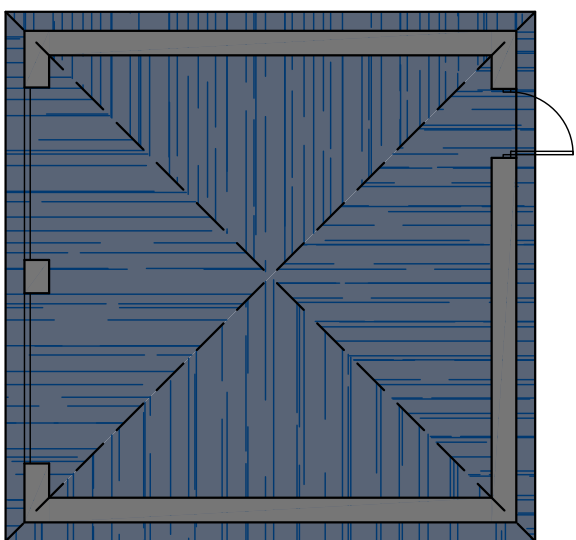

**ROOF PLAN**  
**- DETACHED DOUBLE GARAGE**

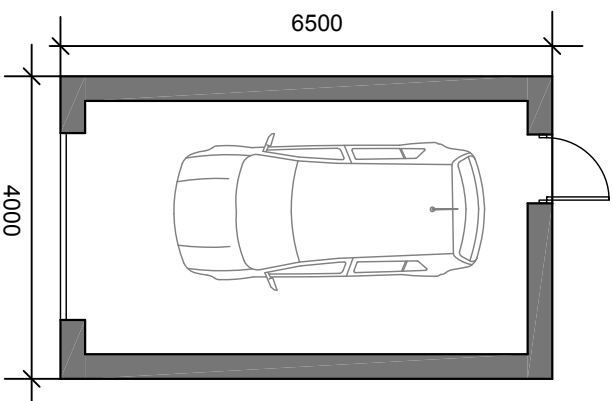

**FLOORPLAN**  
**- DETACHED SINGLE GARAGE**

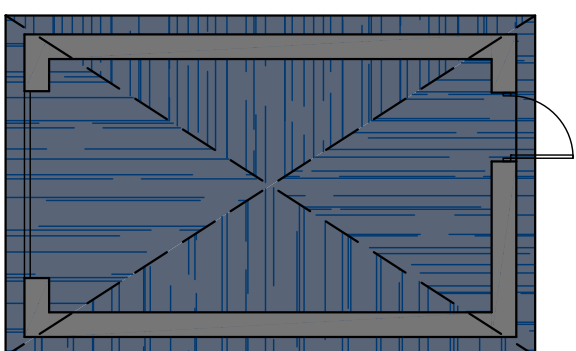

**ROOF PLAN**  
**- DETACHED SINGLE GARAGE**

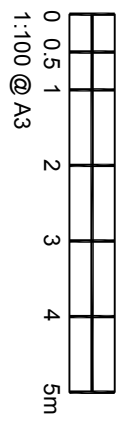

<b>Job Title:</b>	<b>Proposed 4 Bungalows. Pathways Redevelopment. Blackpool Road, Newton A583.</b>
<b>Client:</b>	<b>Mr. S &amp; Mrs. J. Hannan.</b>
<b>Plan Title:</b>	<b>Detached Double &amp; Single Garages - Floor Plan / Roof Plan / Elevations</b>
<b>Scale:</b>	<b>1:100 @ A3</b>
<b>Date:</b>	<b>June 2021</b>
<b>Plan No:</b>	<b>NCR/JC/PATH/10</b>
<b>Revision:</b>	