

Quality and Suitability For Retention

- Category A - High quality and value (Highly desirable for retention)
- Category B - Moderate quality and value (Desirable for retention)
- Category C - Low quality and value (Optional for retention)
- Category U - Poor quality and value (Unsuitable for retention)

Root Protection Areas (RPA)

Root Protection Areas (RPA) identified are in accordance with BS5837:2012. RPA's are shown as a pink dashed polyline

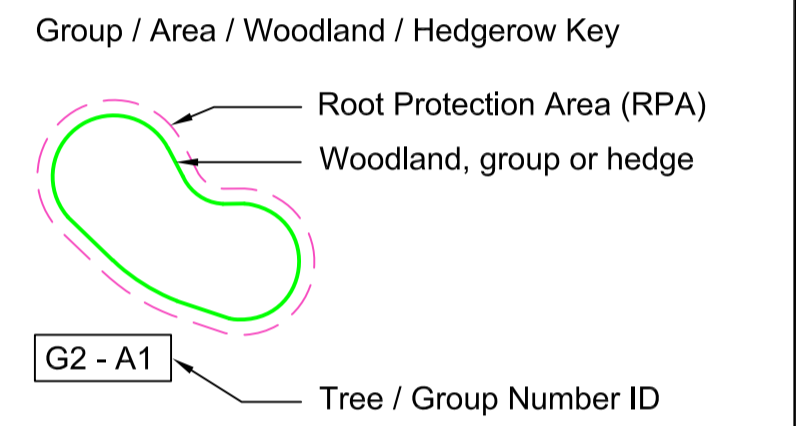
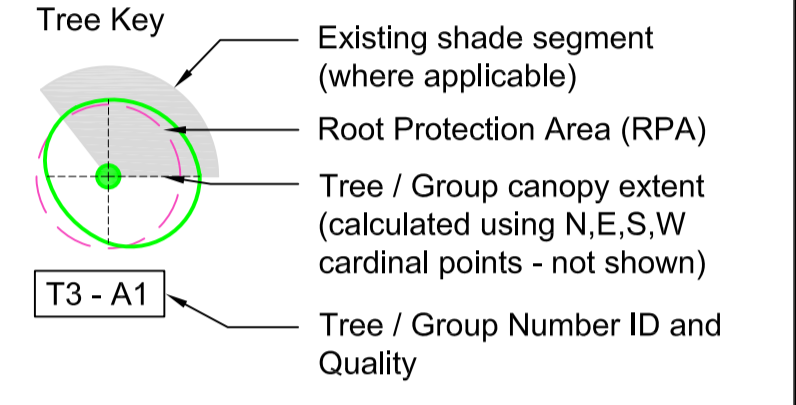

Notes

- 1) Survey Date 27th January 2020.
- 2) This drawing has been produced to be printed in colour. If you have been given this drawing in monochrome please request a colour version.
- 3) Do not scale directly from this drawing.
- 4) This drawing is to be read in conjunction with all other relevant MHP drawings and information supplied by other consultants.

Key

- Tree Protection Fencing
- Area of no dig construction
- Signage 'Construction exclusion zone - No Access'
- Proposed tree
- Visibility splay

Protective Barrier

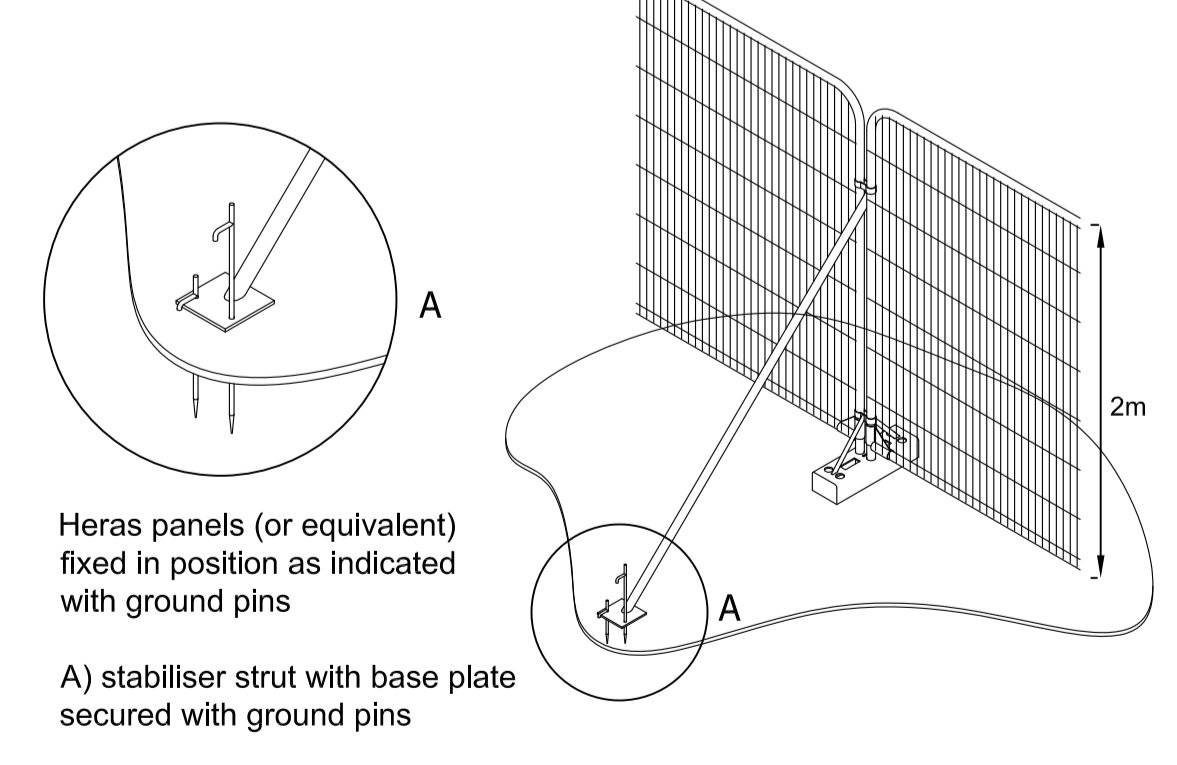

Tree number on plan	Common name	Quality grading	RPA radius (m)
T1	Horse chestnut	B1	6
T2	Common ash	C3	15
T3	Field maple	B1	5
T4	Common ash	C3	15
T5	Field maple	B1	6
H1	Damson, hawthorn, field maple, hazel	B2	As shown on plan
H2	Pear, field maple, hawthorn, crack willow	B2	As shown on plan

Scale

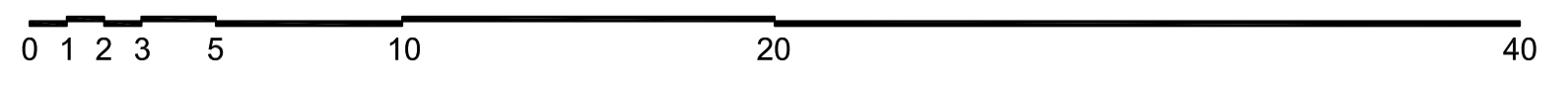

**Land off Rissington Road
Tree Protection Plan**

