

Boundary Wall Elevation

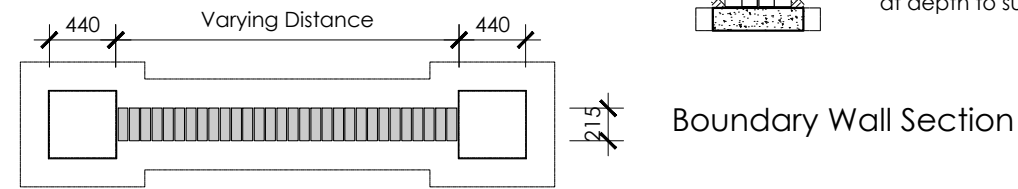

Boundary Wall Plan  
Boundary Type A

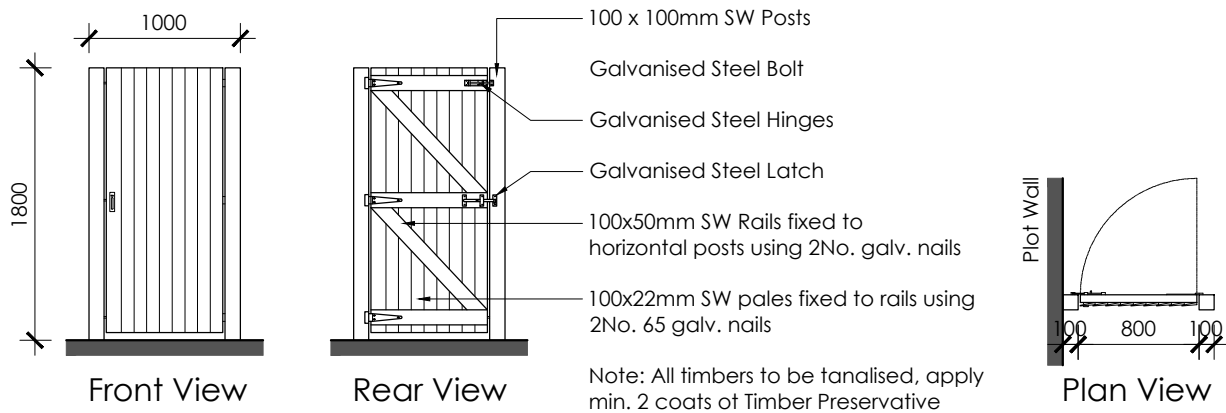

Front View  
Rear View  
Access Gate Details

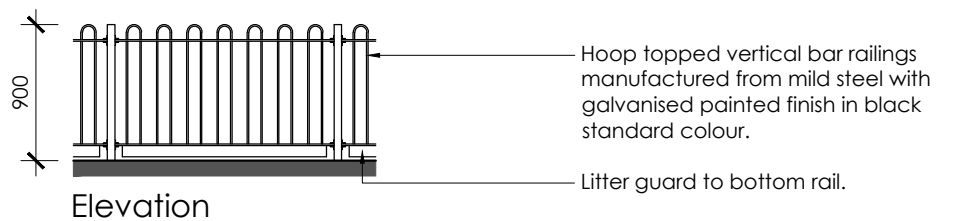

Elevation

Fence lines to be stepped and raked to accommodate sloping ground conditions.

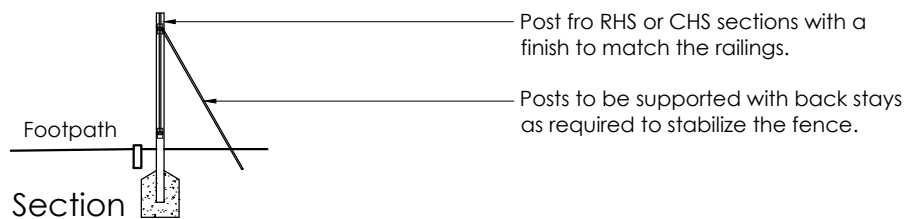

Section

900mm High Bow Top Railings  
Boundary Type D

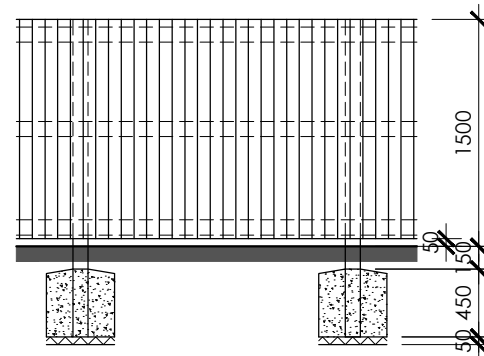

Elevation

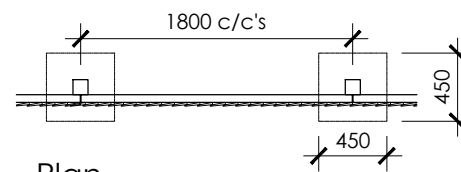

Plan

1.5m High Feathered Edge Fencing  
Boundary Type B

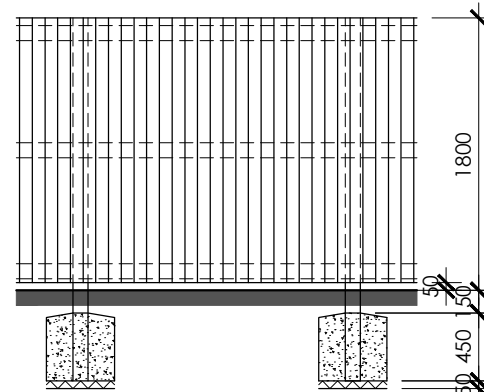

Elevation

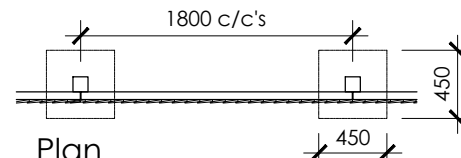

Plan

1.8m High Feathered Edge Fencing  
Boundary Type C

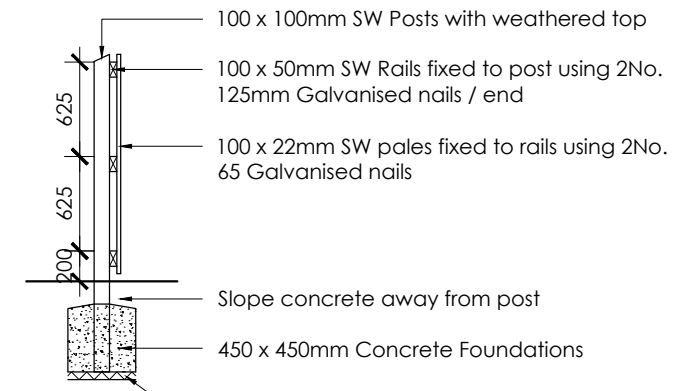

Section

Note: All timbers to be pressure treated

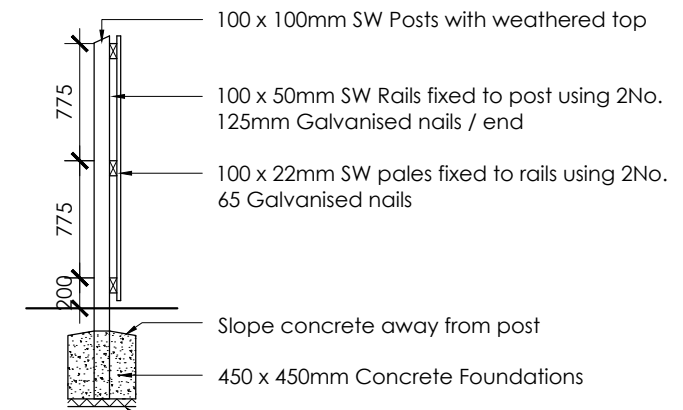

Section

Note: All timbers to be pressure treated

| REV | DATE     | DESCRIPTION                  |
|-----|----------|------------------------------|
| A   | 20.07.21 | Railing line colour amended. |

TITLE  
**BOUNDARY TREATMENTS**

PROJECT  
**CROPPER ROAD, BLACKPOOL**

| DRAWING NUMBER     | DATE    | SCALE     | REV |
|--------------------|---------|-----------|-----|
| CROPPER ROAD - P04 | JULY.21 | 1:50 @ A3 | A   |