

typical elevation of existing front boundary walls....

1:50

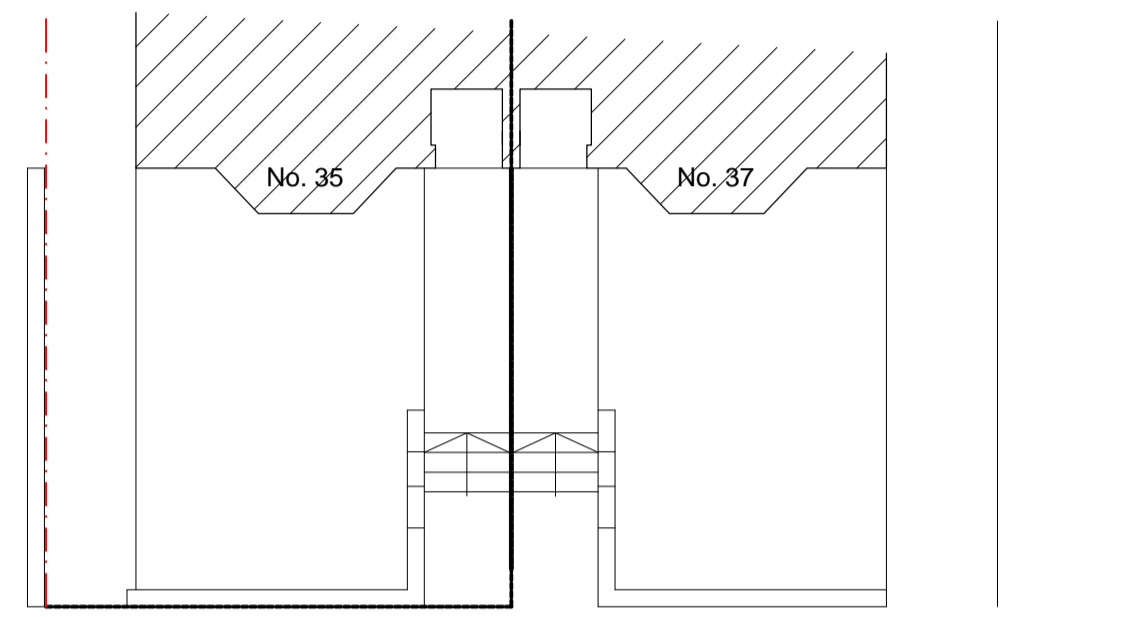

Plan....As Existing...

0.1M
1:100

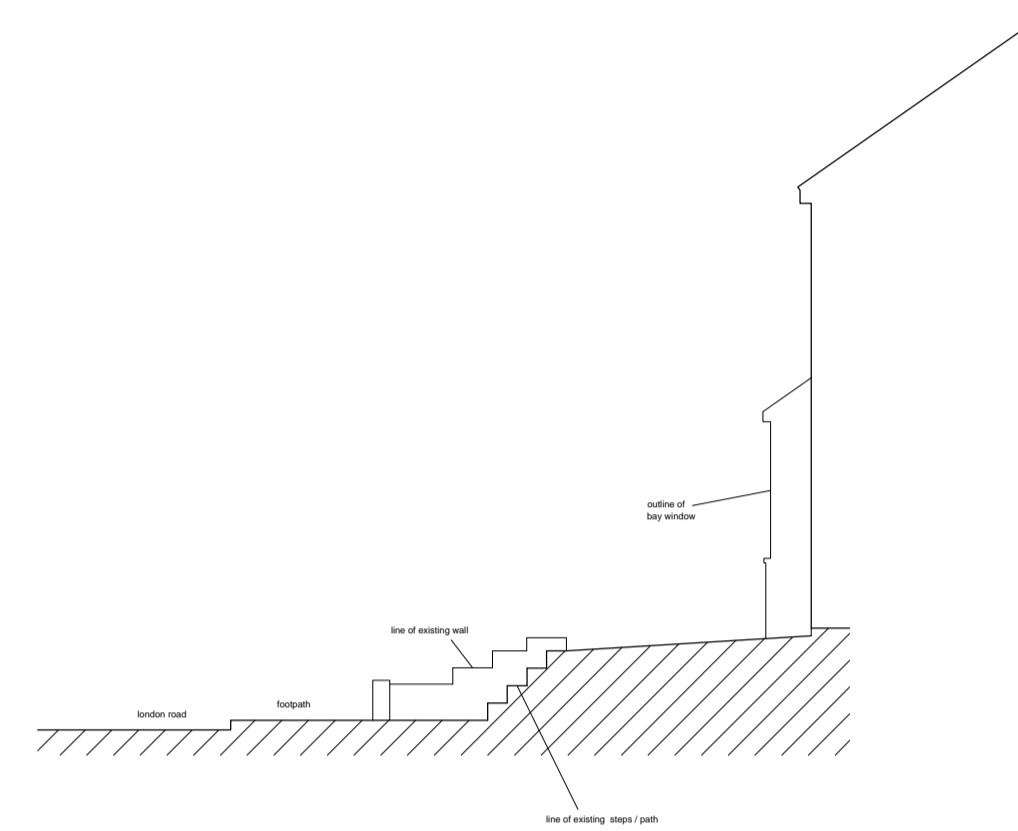

Sectionas existing...



20 0 20 40 60 80 100
Metres

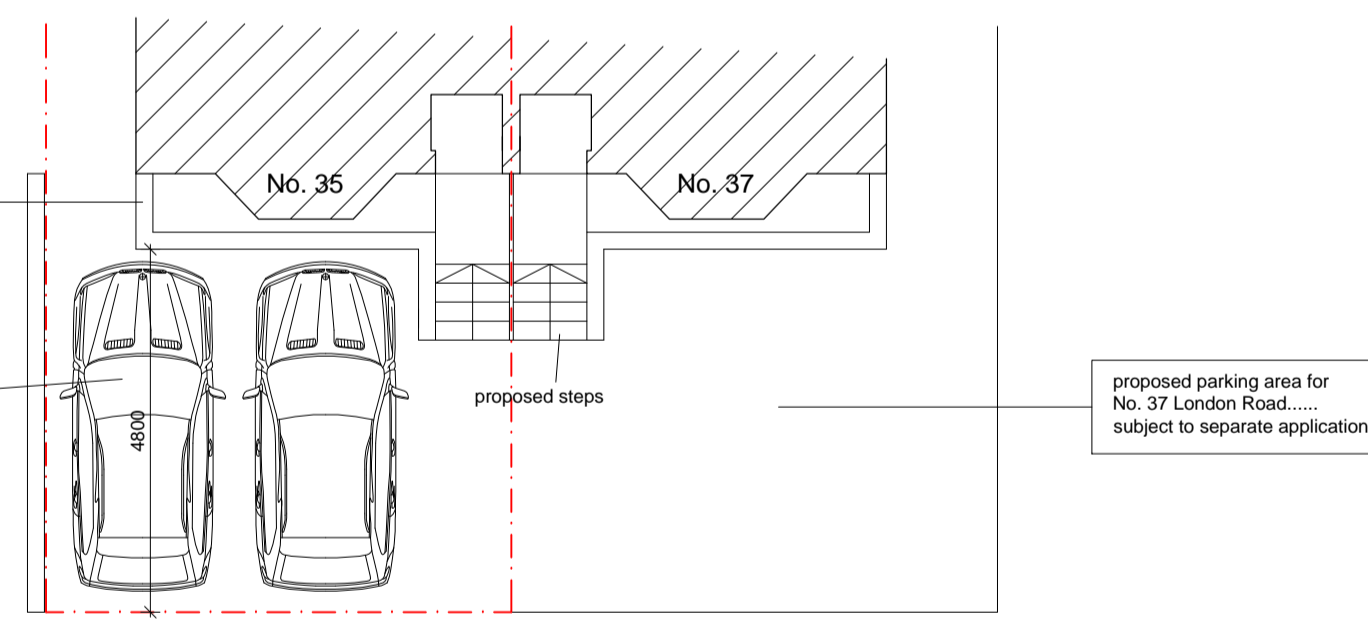

Plan....As Proposed...

0.1M
1:100

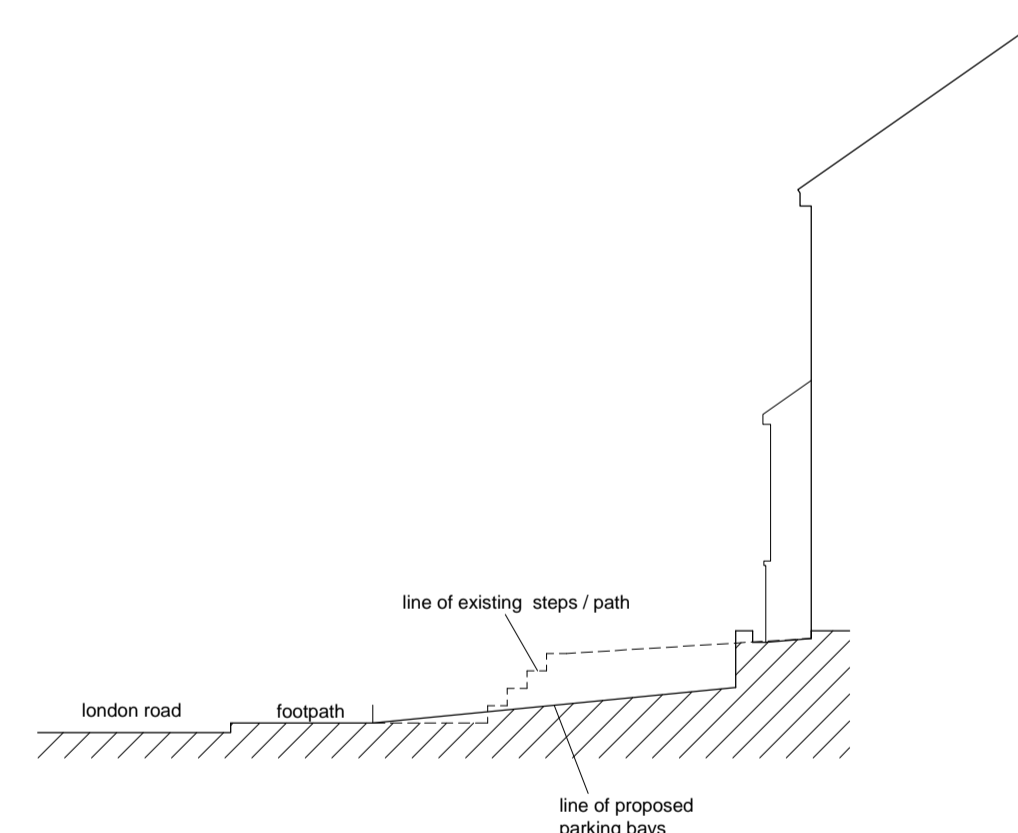

Sectionas proposed...

revision	date	amendment	initials

 South Park Studios,
 South Park
 Sevenoaks,
 Kent,
 TN13 1AN
 tel | 01732 455029 mob | 07721010293 e-mail | barry.best@cobdenland.co.uk web | www.cobdenland.co.uk

project client:
MR. B. CALLAGHAN
35. LONDON ROAD ,
DUNTON GREEN ,
KENT,
TN13 2UB

drawing title: **Planning....**
 date: **sept. 2021** drawn: -
 scale: **1:1250, 1: 50 & 1:100 @ A1**
 drawing no.: **COB/21/1154/01**
 drawing title: **Proposed & Existing details for Parking area....**