

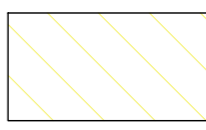

-  FLAT B3  
52sqm - 1b 2p
-  FLAT B4  
53sqm - 1b 2p
-  FLAT A3  
73sqm - 1b 2p

44 THE BROADWAY      40-42 THE BROADWAY      38 THE BROADWAY  
PROJECT NO.

**PROPOSED SECOND FLOOR PLAN**

1m      5m

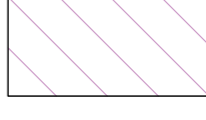
PROJECT	DWG NO.	SCALE	DETAIL	17.09.2021 SUBMITTED TO P.D.E.	21.35	<b>PR Architecture Ltd.</b> Chartered Architect 120, Pinner Road, Harrow, HA1 4JD. Tel: 0208 357 2304
40-42 THE BROADWAY, GREENDFORD, UB6 9PT	08	1:50 @ A1	PROPOSED SECOND FLOOR PLAN			
PLANNING						