

Detail B Cill & Head 1:5

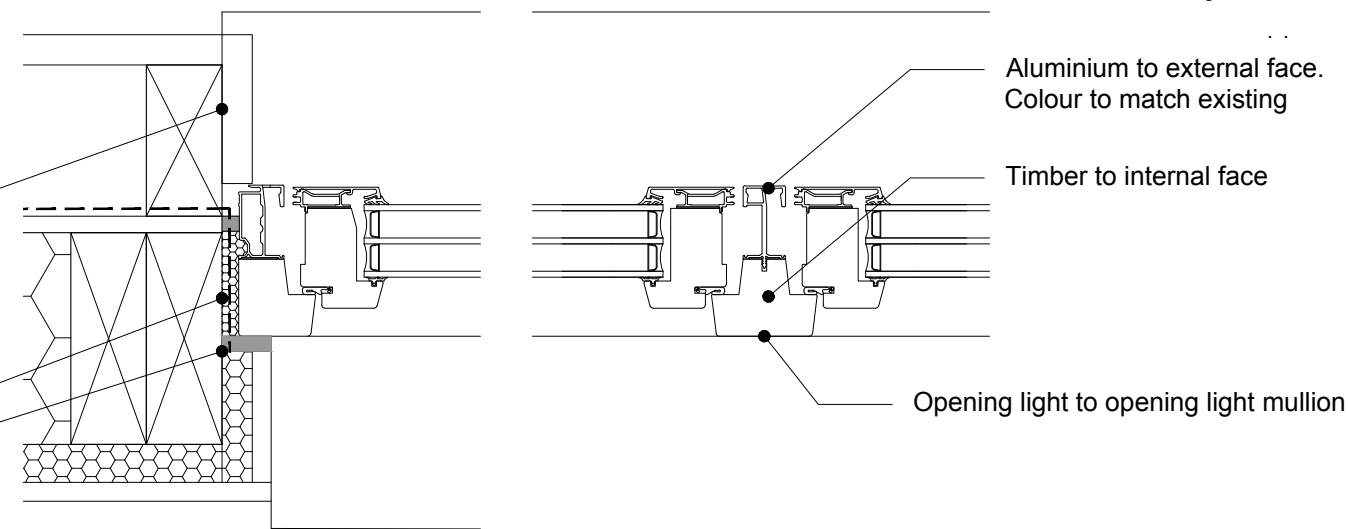

Detail C Jamb 1:5

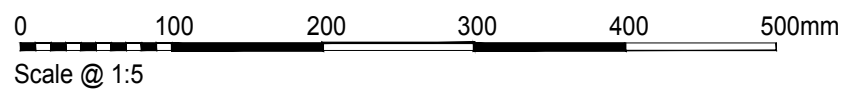
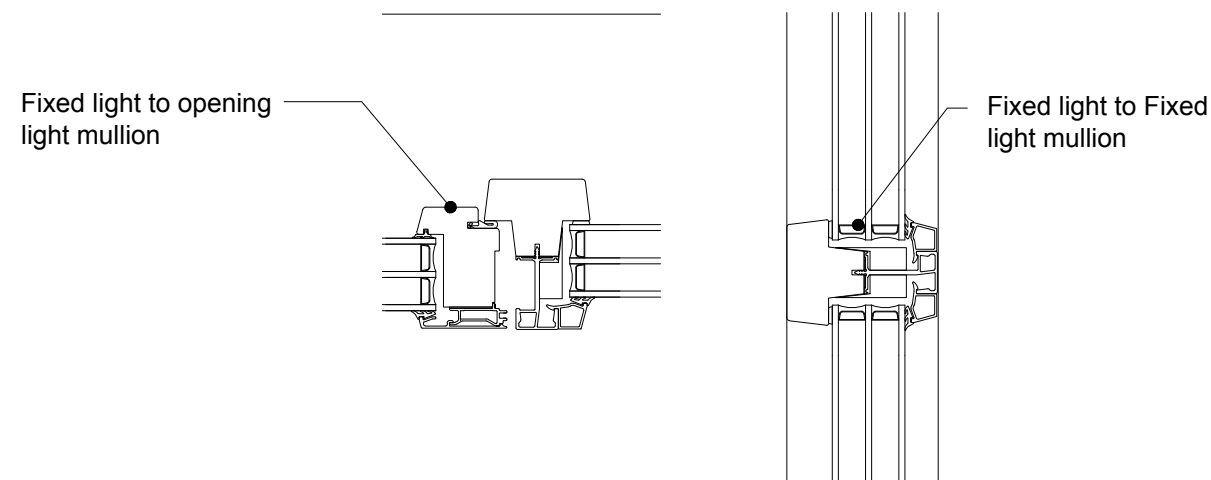

Detail D Profile variants 1:5