

SPLIT-TYPE, HEAT PUMP AIR CONDITIONERS

2017

SERVICE MANUAL

Series PEAD Ceiling Concealed R32/R410A

<indoor unit>

Models PEAD-M35JA(L)
PEAD-M50JA(L)
PEAD-M60JA(L)
PEAD-M71JA(L)
PEAD-M100JA(L)
PEAD-M125JA(L)
PEAD-M140JA(L)

NOTE:

- This manual describes only service data of the indoor units.

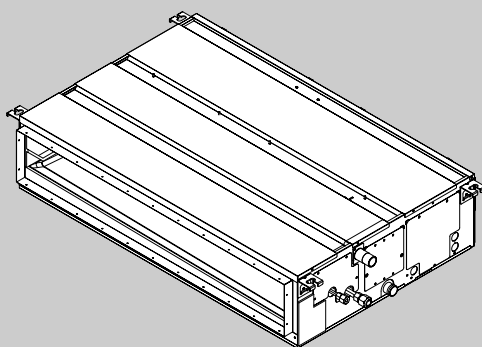

INDOOR UNIT

CONTENTS

1. SAFETY PRECAUTION	2
2. PART NAMES AND FUNCTIONS	7
3. SPECIFICATION	11
4. FAN PERFORMANCE AND CORRECTED AIR FLOW	14
5. SOUND PRESSURE LEVELS	21
6. OUTLINES & DIMENSIONS	28
7. WIRING DIAGRAM	31
8. REFRIGERANT SYSTEM DIAGRAM	32
9. TROUBLESHOOTING	33
10. DISASSEMBLY PROCEDURE	47

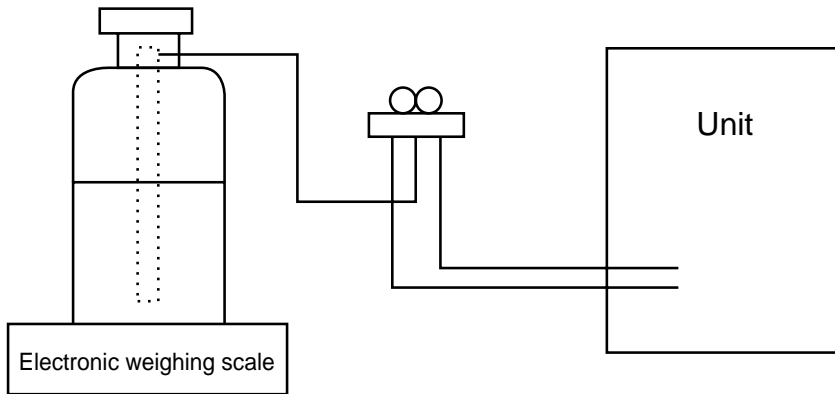

[5] Service tools

Use the below service tools as exclusive tools for R32/R410A refrigerant.

Refer to the spec name plate on outdoor unit for the type of refrigerant being used.

No.	Tool name	Specifications
1.	Gauge manifold	<ul style="list-style-type: none"> · Use the existing fitting specifications. (UNF1/2) · Use high-tension side pressure of 5.3MPa·G or over.
2.	Charge hose	<ul style="list-style-type: none"> · Use pressure performance of 5.09MPa·G or over.
3.	Electronic weighing scale	—
4.	Gas leak detector	<ul style="list-style-type: none"> · Use the detector for R134a, R407, R410A, or R32.
5.	Adaptor for reverse flow check	<ul style="list-style-type: none"> · Attach on vacuum pump.
6.	Refrigerant charge base	—
7.	Refrigerant cylinder	<ul style="list-style-type: none"> · R32 or R410A refrigerant · Cylinder with syphon
8.	Refrigerant recovery equipment	—

2

PART NAMES AND FUNCTIONS

• Indoor Unit

Air intake (sucks the air inside the room into the unit)

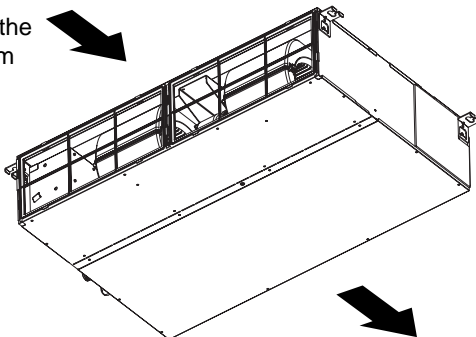

In case of rear inlet

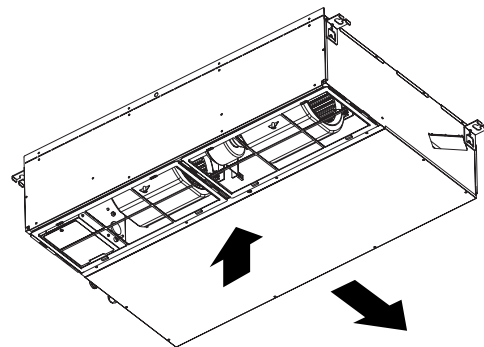

In case of bottom inlet

• Wired remote controller (Option) PAR-32MAA

The functions which can be used are restricted according to each model.

Display

The main display can be displayed in 2 different modes: "Full" and "Basic."
The initial setting is "Full."

Full mode

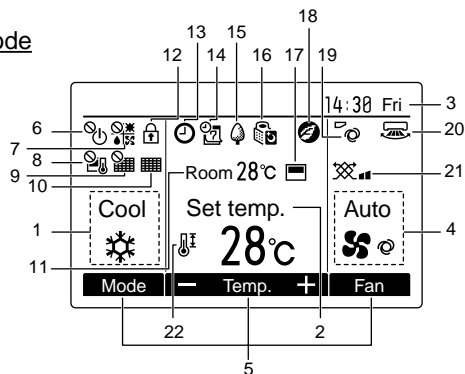

Basic mode

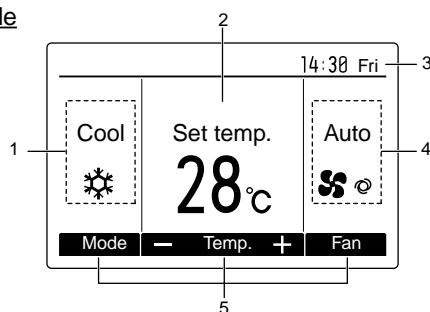

Note: All icons are displayed for explanation.

- 1 Operation mode**
Indoor unit operation mode appears here.
- 2 Preset temperature**
Preset temperature appears here.
- 3 Clock**
(See the Installation Manual.)
Current time appears here.
- 4 Fan speed**
Fan speed setting appears here.
- 5 Button function guide**
Functions of the corresponding buttons appear here.
- 6**
Appears when the ON/OFF operation is centrally controlled.
- 7**
Appears when the operation mode is centrally controlled.
- 8**
Appears when the preset temperature is centrally controlled.
- 9**
Appears when the filter reset function is centrally controlled.
- 10**
Indicates when filter needs maintenance.
- 11 Room temperature**
(See the Installation Manual.)
Current room temperature appears here.
- 12**
Appears when the buttons are locked.
- 13**
Appears when the On/Off timer or Night setback function is enabled.
- 14**
Appears when the Weekly timer is enabled.
- 15**
Appears while the units are operated in the energy-save mode.
- 16**
Appears while the outdoor units are operated in the silent mode.
- 17**
Appears when the built-in thermistor on the remote controller is activated to monitor the room temperature (a).
appears when the thermistor on the indoor unit is activated to monitor the room temperature.
- 18**
Appears when the units are operated in the energy-save mode with 3D i-see Sensor.
- 19**
Indicates the vane setting.
- 20**
Indicates the louver setting.
- 21**
Indicates the ventilation setting.
- 22**
Appears when the preset temperature range is restricted.

Controller interface

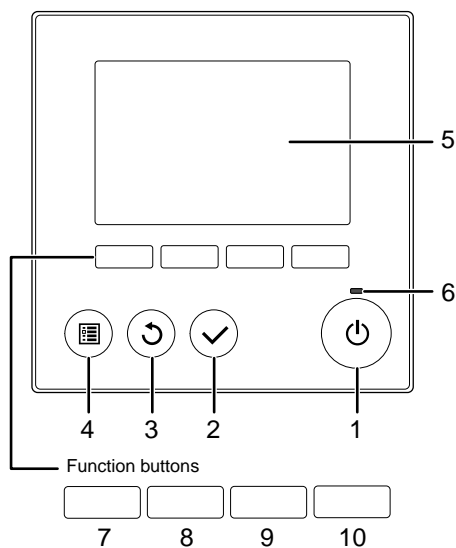

- When the backlight is off, pressing any button turns the backlight on and does not perform its function. (except for the ON/OFF button)
- Most settings (except ON/OFF, mode, fan speed, temperature) can be made from the Menu screen.

- 1 ON/OFF button**
Press to turn ON/OFF the indoor unit.
- 2 SELECT button**
Press to save the setting.
- 3 RETURN button**
Press to return to the previous screen.
- 4 MENU button**
Press to bring up the Main menu.
- 5 Backlit LCD**
Operation settings will appear. When the backlight is off, pressing any button turns the backlight on and it will stay lit for a certain period of time depending on the screen.
- 6 ON/OFF lamp**
This lamp lights up in green while the unit is in operation. It blinks while the remote controller is starting up or when there is an error.

The functions of the function buttons change depending on the screen. Refer to the button function guide that appears at the bottom of the LCD for the functions they serve on a given screen. When the system is centrally controlled, the button function guide that corresponds to the locked button will not appear.

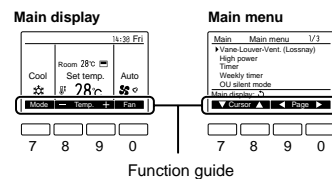

- 7 Function button F1**
Main display: Press to change the operation mode.
Main menu: Press to move the cursor down.
- 8 Function button F2**
Main display: Press to decrease temperature.
Main menu: Press to move the cursor up.
- 9 Function button F3**
Main display: Press to increase temperature.
Main menu: Press to go to the previous page.
- 10 Function button F4**
Main display: Press to change the fan speed.
Main menu: Press to go to the next page.

Menu structure

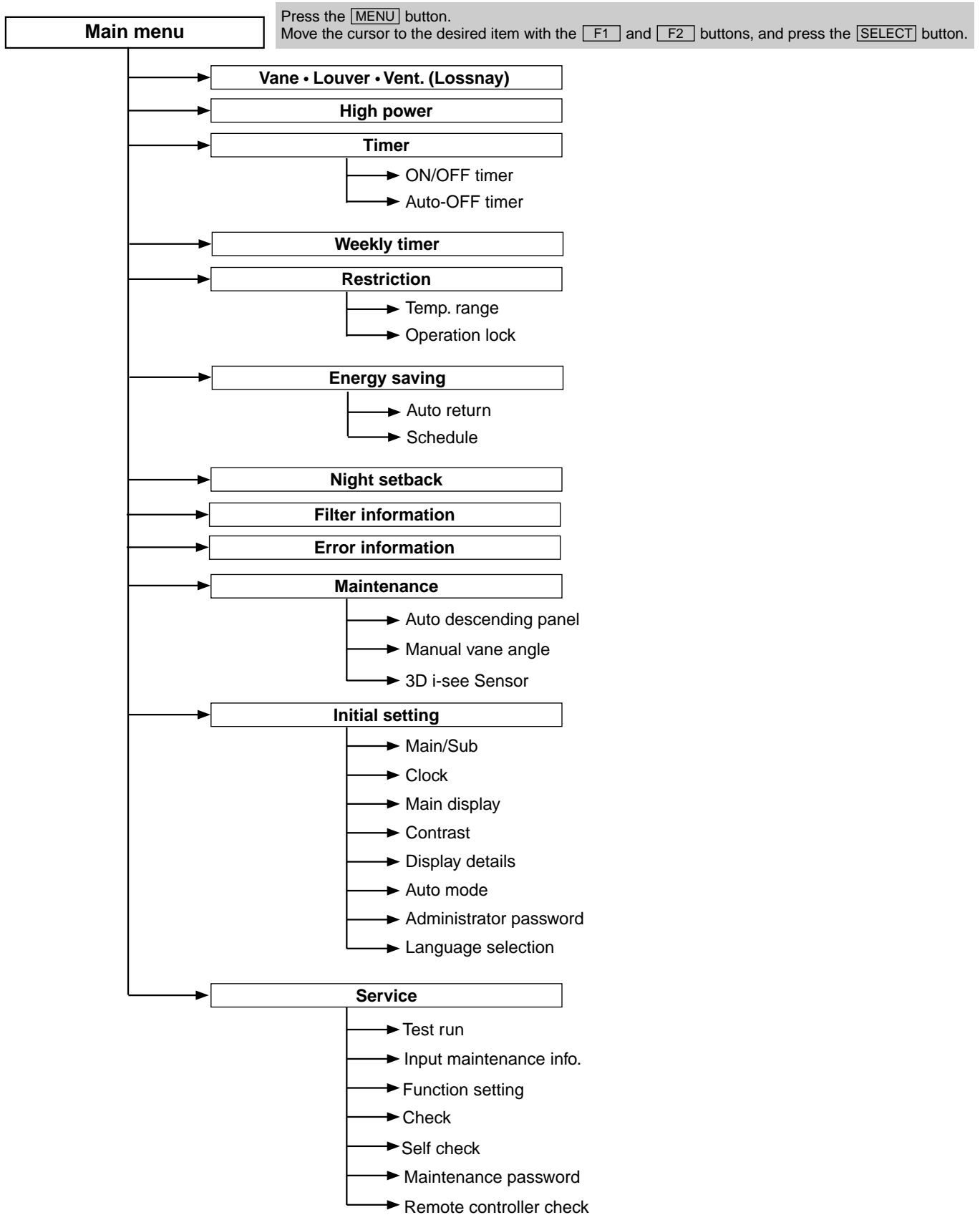

Not all functions are available on all models of indoor units.



Setting and display items		Setting details
Vane · Louver · Vent. (Lossnay)		<p>Use to set the vane angle.</p> <ul style="list-style-type: none"> • Select a desired vane setting from 5 different settings. <p>Use to turn ON/OFF the louver.</p> <ul style="list-style-type: none"> • Select a desired setting from "ON" and "OFF." <p>Use to set the amount of ventilation.</p> <ul style="list-style-type: none"> • Select a desired setting from "OFF," "Low," and "High."
High power		<p>Use to reach the comfortable room temperature quickly.</p> <ul style="list-style-type: none"> • Units can be operated in the High-power mode for up to 30 minutes.
Timer	ON/OFF timer*	<p>Use to set the operation ON/OFF times.</p> <ul style="list-style-type: none"> • Time can be set in 5-minute increments.
	Auto-Off timer	<p>Use to set the Auto-OFF time.</p> <ul style="list-style-type: none"> • Time can be set to a value from 30 to 240 in 10-minute increments.
Filter information		<p>Use to check the filter status.</p> <ul style="list-style-type: none"> • The filter sign can be reset.
Error information		<p>Use to check error information when an error occurs.</p> <ul style="list-style-type: none"> • Check code, error source, refrigerant address, unit model, manufacturing number, contact information (dealer's phone number) can be displayed. (The unit model, manufacturing number, and contact information need to be registered in advance to be displayed.)
Weekly timer*		<p>Use to set the weekly operation ON/OFF times.</p> <ul style="list-style-type: none"> • Up to 8 operation patterns can be set for each day. (Not valid when the ON/OFF timer is enabled.)
Energy saving	Auto return	<p>Use to get the units to operate at the preset temperature after performing energy-save operation for a specified time period.</p> <ul style="list-style-type: none"> • Time can be set to a value from 30 and 120 in 10-minute increments. (This function will not be valid when the preset temperature ranges are restricted.)
	Schedule*	<p>Set the start/stop times to operate the units in the energy-save mode for each day of the week, and set the energy-saving rate.</p> <ul style="list-style-type: none"> • Up to 4 energy-save operation patterns can be set for each day. • Time can be set in 5-minute increments. • Energy-saving rate can be set to a value from 0% and 50 to 90% in 10% increments.
Night setback*		<p>Use to make Night setback settings.</p> <ul style="list-style-type: none"> • Select "Yes" to enable the setting, and "No" to disable the setting. The temperature range and the start/stop times can be set.
Restriction	Temp. range	<p>Use to restrict the preset temperature range.</p> <ul style="list-style-type: none"> • Different temperature ranges can be set for different operation modes.
	Operation lock	<p>Use to lock selected functions.</p> <ul style="list-style-type: none"> • The locked functions cannot be operated.
Initial setting	Main/Sub	When connecting 2 remote controllers, one of them needs to be designated as a sub controller.
	Clock	Use to set the current time.
	Main display	<p>Use to switch between "Full" and "Basic" modes for the Main display.</p> <ul style="list-style-type: none"> • The initial setting is "Full."
	Contrast	Use to adjust screen contrast.
Initial setting	Display details	<p>Make the settings for the remote controller related items as necessary.</p> <p>Clock: The initial settings are "Yes" and "24h" format. Temperature: Set either Celsius (°C) or Fahrenheit (°F). Room temp. : Set Show or Hide. Auto mode: Set the Auto mode display or Only Auto display.</p>
	Auto mode	<p>Whether or not to use the AUTO mode can be selected by using the button.</p> <p>This setting is valid only when indoor units with the AUTO mode function are connected.</p>
	Administrator password	<p>The administrator password is required to make the settings for the following items.</p> <ul style="list-style-type: none"> • Timer setting • Energy-save setting • Weekly timer setting • Restriction setting • Outdoor unit silent mode setting • Night set back
	Language selection	Use to select the desired language.
Service	Test run	<p>Select "Test run" from the Service menu to bring up the Test run menu.</p> <ul style="list-style-type: none"> • Test run • Drain pump test run
	Input maintenance	<p>Select "Input maintenance Info." from the Service menu to bring up the Maintenance information screen. The following settings can be made from the Maintenance Information screen.</p> <ul style="list-style-type: none"> • Model name input • Serial No. input • Dealer information input
	Function setting	Make the settings for the indoor unit functions via the remote controller as necessary.
	LOSSNAY setting (City Multi only)	This setting is required only when the operation of City Multi units is interlocked with LOSSNAY units.
	Check	<p>Error history: Display the error history and execute "delete error history". Refrigerant leak check: Refrigerant leaks can be judged. Smooth maintenance: The indoor and outdoor maintenance data can be displayed. Request code: Details of the operation data including each thermistor temperature and error history can be checked.</p>
	Self check	Error history of each unit can be checked via the remote controller.
	Maintenance password	Use to change the maintenance password.
Remote controller check	When the remote controller does not work properly, use the remote controller checking function to troubleshoot the problem.	

* Clock setting is required.

3

SPECIFICATION

Service Ref.			PEAD-M35JA(L)	
Mode			Cooling	Heating
Power supply			Single phase, 50Hz, 220-240V	
Input	* 1	kW	0.09 (0.07)	0.07
Running Current	* 1	A	0.64 (0.53)	0.53
External finish			Galvanized sheets	
Heat exchanger			Plate fin coil	
Fan	Fan (drive) × No.		Sirocco fan × 1	
	Fan motor output	kW	0.085	
	Airflow (Low-Mid-High)	m ³ /min (CFM)	10.0-12.0-14.0 (353-424-494)	
	External static pressure	Pa	35-50-70-100-150	
Booster heater			kW	
Operation control & Thermostat			Remote controller & built-in	
Sound pressure level (Low-Mid-High)	35Pa	dB (A)	23-26-29	
	50Pa		23-27-30	
	70Pa		24-28-31	
	100Pa		26-29-33	
	150Pa		29-33-37	
Field drain pipe O.D			mm (in.)	
Dimensions	W	mm (in.)	32 (1-1/4)	
	D	mm (in.)	900 (35-7/16)	
	H	mm (in.)	732 (28-7/8)	
Weight	* 1	kg	250 (9-7/8)	
		lbs	26 (25)	
			58 (56)	

Service Ref.			PEAD-M50JA(L)	
Mode			Cooling	Heating
Power supply			Single phase, 50Hz, 220-240V	
Input	* 1	kW	0.11 (0.09)	0.09
Running Current	* 1	A	0.90 (0.79)	0.79
External finish			Galvanized sheets	
Heat exchanger			Plate fin coil	
Fan	Fan (drive) × No.		Sirocco fan × 1	
	Fan motor output	kW	0.085	
	Airflow (Low-Mid-High)	m ³ /min (CFM)	12.0-14.5-17.0 (424-512-600)	
	External static pressure	Pa	35-50-70-100-150	
Booster heater			kW	
Operation control & Thermostat			Remote controller & built-in	
Sound pressure level (Low-Mid-High)	35Pa	dB (A)	25-30-34	
	50Pa		26-31-35	
	70Pa		28-32-36	
	100Pa		29-33-37	
	150Pa		31-35-39	
Field drain pipe O.D			mm (in.)	
Dimensions	W	mm (in.)	32 (1-1/4)	
	D	mm (in.)	900 (35-7/16)	
	H	mm (in.)	732 (28-7/8)	
Weight	* 1	kg	250 (9-7/8)	
		lbs	27 (26)	
			60 (57)	

Service Ref.			PEAD-M60JA(L)	
Mode			Cooling	Heating
Power supply			Single phase, 50Hz, 220-240V	
Input	* 1	kW	0.12 (0.10)	0.10
Running Current	* 1	A	1.00 (0.89)	0.89
External finish			Galvanized sheets	
Heat exchanger			Plate fin coil	
Fan	Fan (drive) × No.		Sirocco fan × 2	
	Fan motor output	kW	0.121	
	Airflow (Low-Mid-High)	m ³ /min (CFM)	14.5-18.0-21.0 (512-636-742)	
	External static pressure	Pa	35-50-70-100-150	
Booster heater			kW	
Operation control & Thermostat			Remote controller & built-in	
Sound pressure level (Low-Mid-High)	35Pa	dB (A)	25-28-32	
	50Pa		25-29-33	
	70Pa		26-30-34	
	100Pa		27-31-35	
	150Pa		29-34-38	
Field drain pipe O.D			mm (in.)	
Dimensions	W	mm (in.)	32 (1-1/4)	
	D	mm (in.)	1100 (43-5/16)	
	H	mm (in.)	732 (28-7/8)	
Weight	* 1	kg	250 (9-7/8)	
		lbs	30 (29)	
			66 (64)	

*1 Figures in the parentheses indicate drainpump-less Model (L).

Service Ref.			PEAD-M71JA(L)	
Mode			Cooling	Heating
Power supply			Single phase, 50Hz, 220-240V	
Input	* 1	kW	0.17 (0.15)	0.15
Running Current	* 1	A	1.28 (1.17)	1.17
External finish			Galvanized sheets	
Heat exchanger			Plate fin coil	
Fan	Fan (drive) × No.		Sirocco fan × 2	
	Fan motor output	kW	0.121	
	Airflow (Low-Mid-High)	m ³ /min (CFM)	17.5-21.0-25.0 (618-742-883)	
	External static pressure	Pa	35-50-70-100-150	
Booster heater			kW	
Operation control & Thermostat			Remote controller & built-in	
Sound pressure level (Low-Mid-High)	35Pa	dB (A)	25-29-34	
	50Pa		26-30-34	
	70Pa		27-31-35	
	100Pa		28-32-36	
	150Pa		30-35-39	
Field drain pipe O.D			mm (in.)	
Dimensions	W	mm (in.)	1100 (43-5/16)	
	D	mm (in.)	732 (28-7/8)	
	H	mm (in.)	250 (9-7/8)	
Weight	* 1	kg	30 (29)	
		lbs	66 (64)	

Service Ref.			PEAD-M100JA(L)	
Mode			Cooling	Heating
Power supply			Single phase, 50Hz, 220-240V	
Input	* 1	kW	0.25 (0.23)	0.23
Running Current	* 1	A	1.68 (1.57)	1.57
External finish			Galvanized sheets	
Heat exchanger			Plate fin coil	
Fan	Fan (drive) × No.		Sirocco fan × 2	
	Fan motor output	kW	0.244	
	Airflow (Low-Mid-High)	m ³ /min (CFM)	24.0-29.0-34.0 (847-1024-1201)	
	External static pressure	Pa	35-50-70-100-150	
Booster heater			kW	
Operation control & Thermostat			Remote controller & built-in	
Sound pressure level (Low-Mid-High)	35Pa	dB (A)	28-33-38	
	50Pa		29-34-38	
	70Pa		30-35-39	
	100Pa		31-36-40	
	150Pa		34-40-43	
Field drain pipe O.D			mm (in.)	
Dimensions	W	mm (in.)	1400 (55-1/8)	
	D	mm (in.)	732 (28-7/8)	
	H	mm (in.)	250 (9-7/8)	
Weight	* 1	kg	39 (38)	
		lbs	86 (84)	

Service Ref.			PEAD-M125JA(L)	
Mode			Cooling	Heating
Power supply			Single phase, 50Hz, 220-240V	
Input	* 1	kW	0.36 (0.34)	0.34
Running Current	* 1	A	2.40 (2.29)	2.29
External finish			Galvanized sheets	
Heat exchanger			Plate fin coil	
Fan	Fan (drive) × No.		Sirocco fan × 2	
	Fan motor output	kW	0.244	
	Airflow (Low-Mid-High)	m ³ /min (CFM)	29.5-35.5-42.0 (1042-4254-1483)	
	External static pressure	Pa	35-50-70-100-150	
Booster heater			kW	
Operation control & Thermostat			Remote controller & built-in	
Sound pressure level (Low-Mid-High)	35Pa	dB (A)	31-36-40	
	50Pa		33-36-40	
	70Pa		33-37-41	
	100Pa		34-39-42	
	150Pa		37-41-45	
Field drain pipe O.D			mm (in.)	
Dimensions	W	mm (in.)	1400 (55-1/8)	
	D	mm (in.)	732 (28-7/8)	
	H	mm (in.)	250 (9-7/8)	
Weight	* 1	kg	40 (39)	
		lbs	88 (86)	

*1 Figures in the parentheses indicate drainpump-less Model (L).



Service Ref.			PEAD-M140JA(L)	
Mode			Cooling	Heating
Power supply			Single phase, 50Hz, 220-240V	
	Input * 1	kW	0.39 (0.37)	0.37
	Running Current * 1	A	2.60 (2.49)	2.49
External finish			Galvanized sheets	
Heat exchanger			Plate fin coil	
INDOOR UNIT	Fan (drive) × No.		Sirocco fan × 2	
	Fan motor output		0.244	
	Airflow (Low-Mid-High)		32.0-39.0-46.0 (1130-1377-1624)	
	External static pressure		35-50-70-100-150	
Booster heater		kW	-	
Operation control & Thermostat			Remote controller & built-in	
Sound pressure level (Low-Mid-High)	35Pa	dB (A)	33-37-43	
	50Pa		34-38-43	
	70Pa		34-39-44	
	100Pa		36-40-45	
	150Pa		38-42-46	
Field drain pipe O.D		mm (in.)	32 (1-1/4)	
Dimensions	W	mm (in.)	1600 (63)	
	D	mm (in.)	732 (28-7/8)	
	H	mm (in.)	250 (9-7/8)	
Weight * 1		kg	44 (43)	
		lbs	97 (95)	

*1 Figures in the parentheses indicate drainpump-less Model (L).

PEAD-M35JA(L)

(External static pressure 35Pa) 220-240V 50Hz

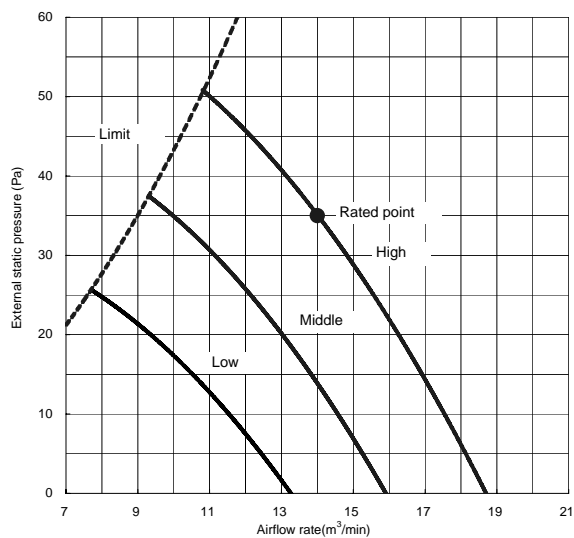

PEAD-M35JA(L)

(External static pressure 100Pa) 220-240V 50Hz

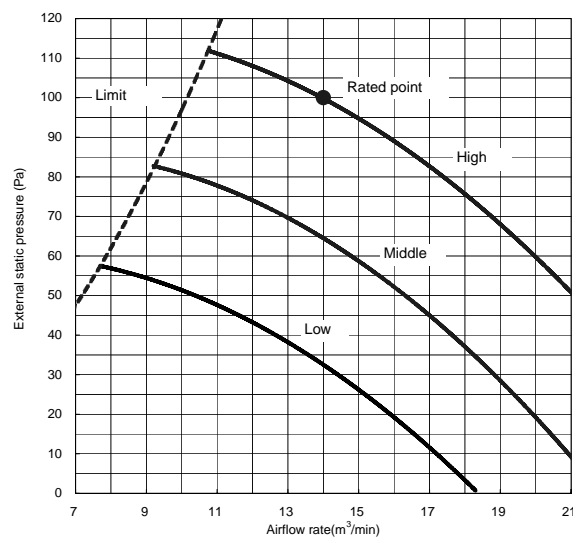

PEAD-M35JA(L)

(External static pressure 50Pa) 220-240V 50Hz

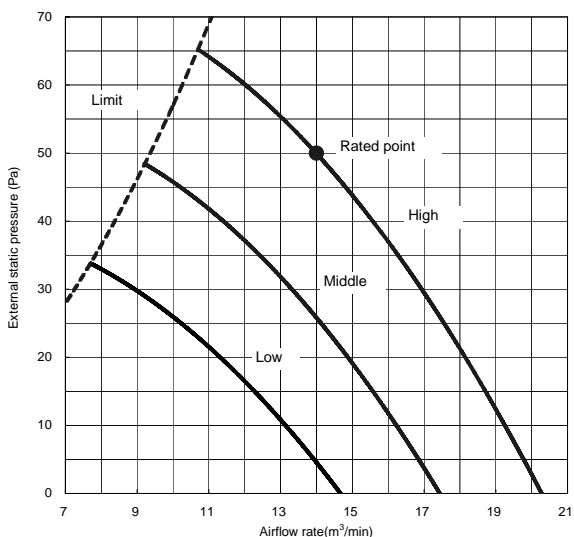

PEAD-M35JA(L)

(External static pressure 150Pa) 220-240V 50Hz

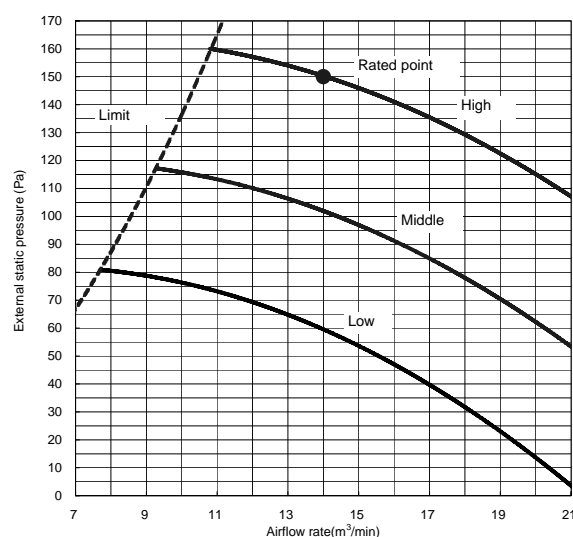

PEAD-M35JA(L)

(External static pressure 70Pa) 220-240V 50Hz

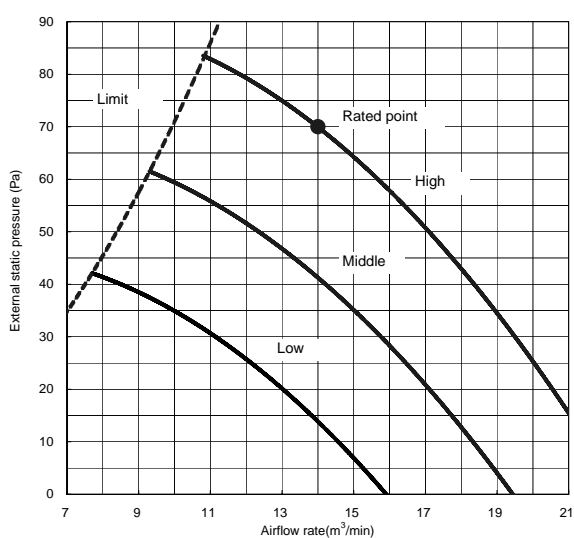

PEAD-M50JA(L)

(External static pressure 35Pa) 220-240V 50Hz

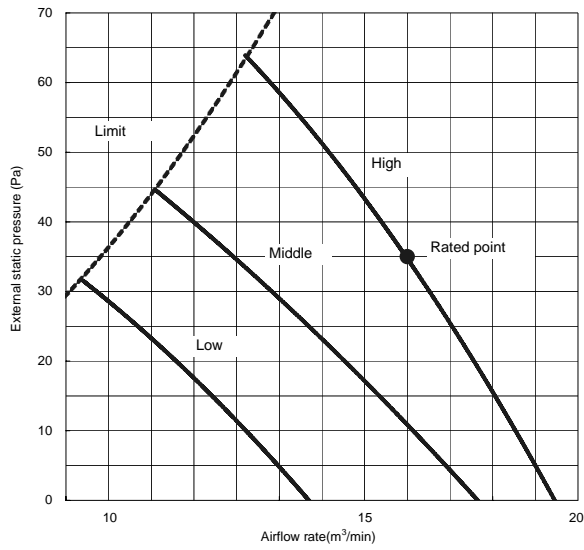

PEAD-M50JA(L)

(External static pressure 100Pa) 220-240V 50Hz

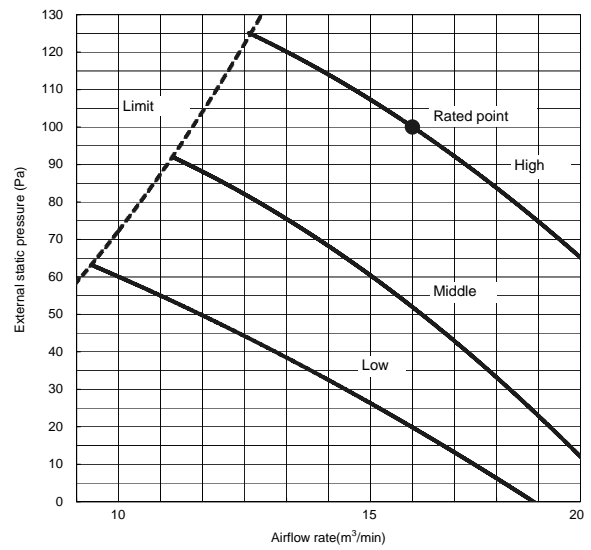

PEAD-M50JA(L)

(External static pressure 50Pa) 220-240V 50Hz

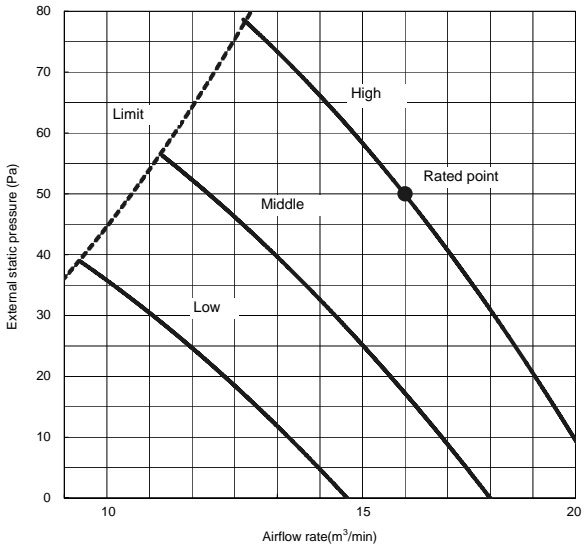

PEAD-M50JA(L)

(External static pressure 150Pa) 220-240V 50Hz

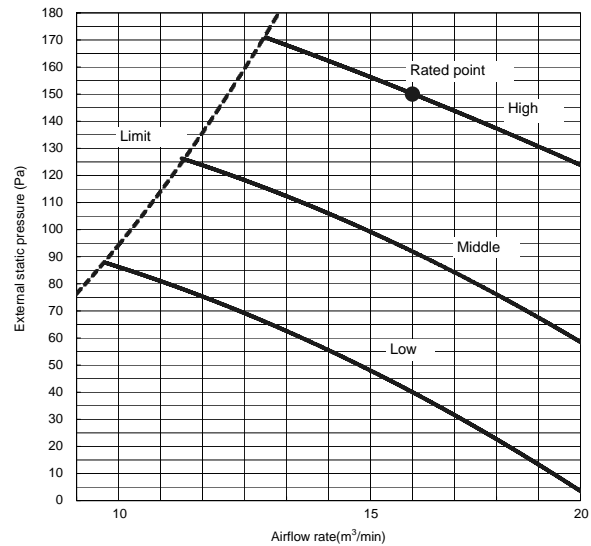

PEAD-M50JA(L)

(External static pressure 70Pa) 220-240V 50Hz

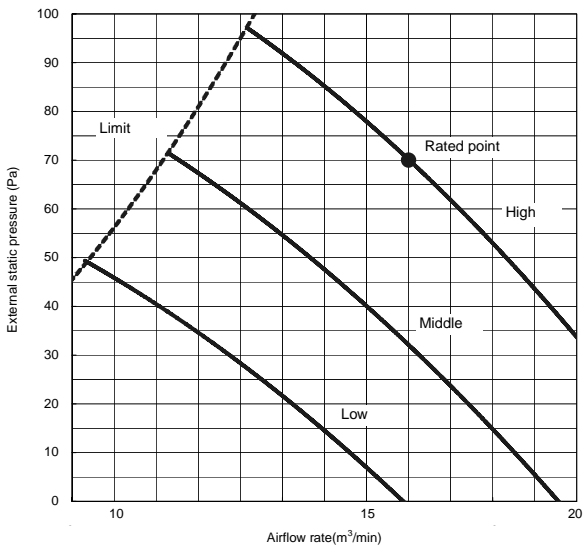

PEAD-M60JA(L)

(External static pressure 35Pa) 220-240V 50Hz

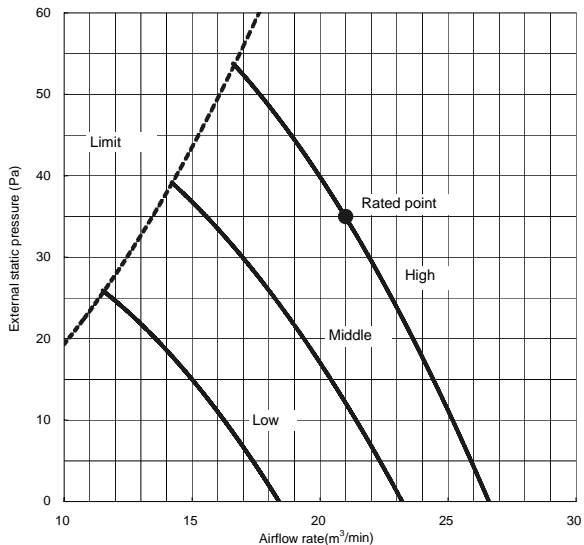

PEAD-M60JA(L)

(External static pressure 100Pa) 220-240V 50Hz

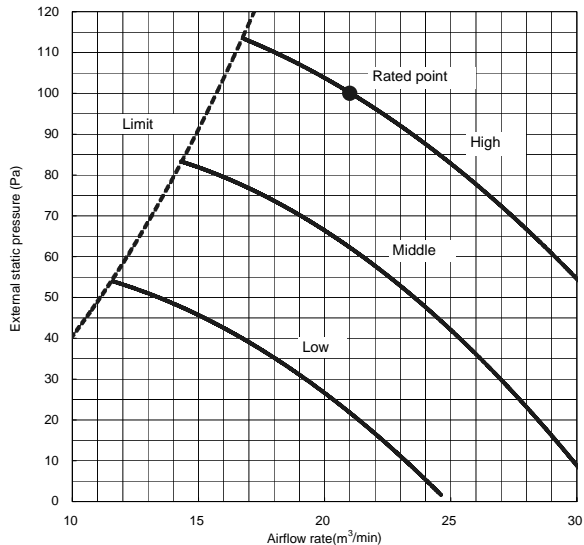

PEAD-M60JA(L)

(External static pressure 50Pa) 220-240V 50Hz

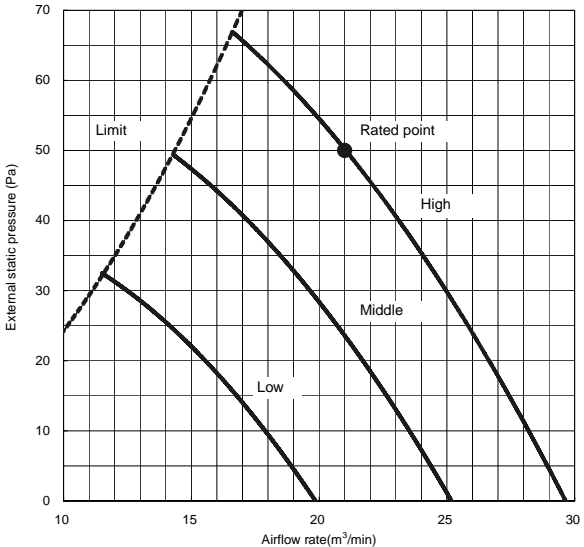

PEAD-M60JA(L)

(External static pressure 150Pa) 220-240V 50Hz

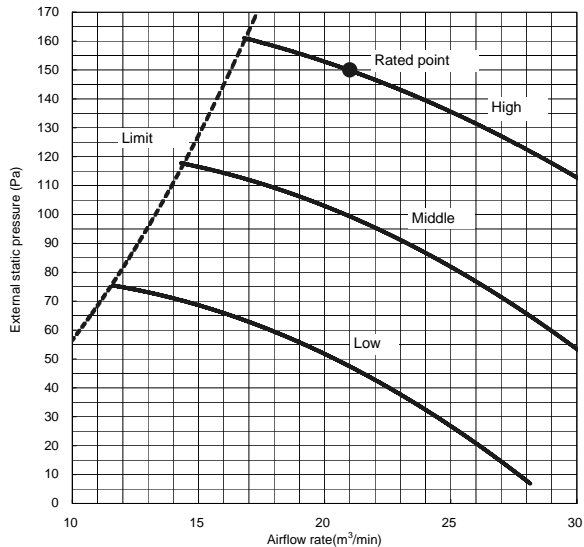

PEAD-M60JA(L)

(External static pressure 70Pa) 220-240V 50Hz

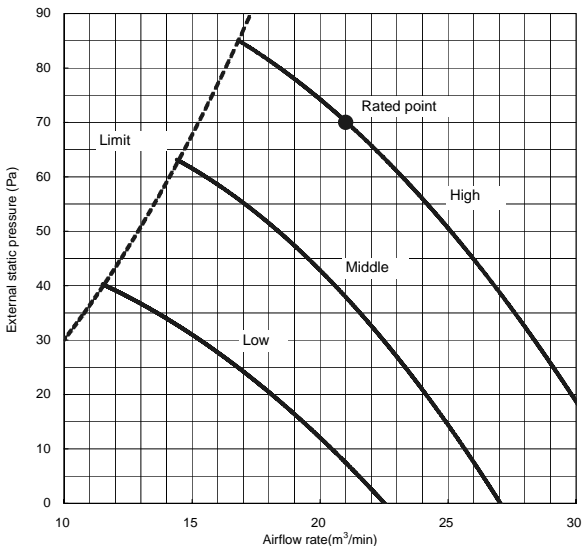

PEAD-M71JA(L)

(External static pressure 35Pa) 220-240V 50Hz

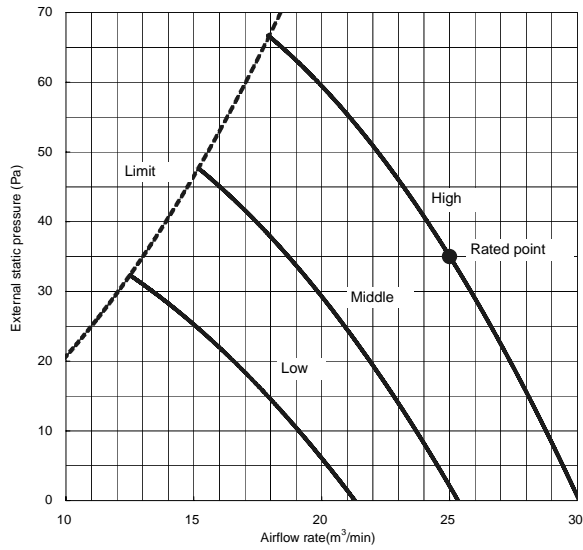

PEAD-M71JA(L)

(External static pressure 100Pa) 220-240V 50Hz

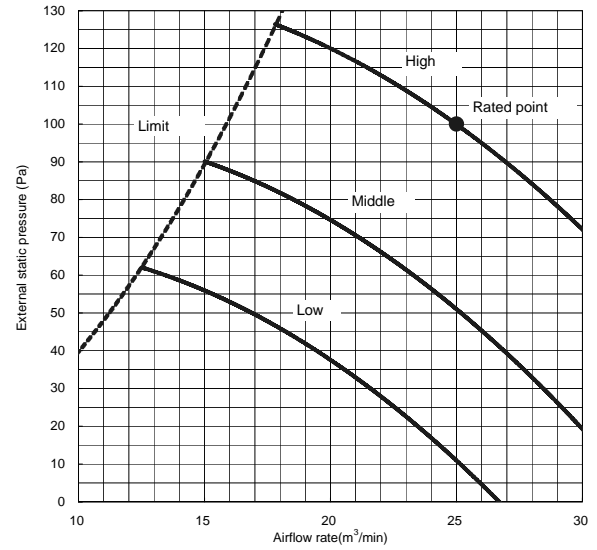

PEAD-M71JA(L)

(External static pressure 50Pa) 220-240V 50Hz

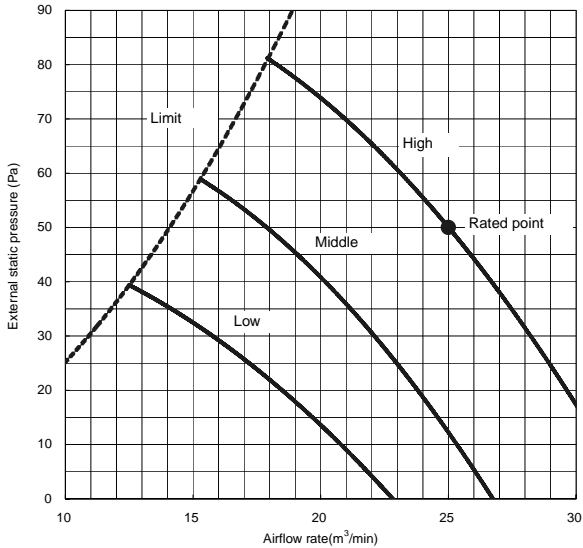

PEAD-M71JA(L)

(External static pressure 150Pa) 220-240V 50Hz

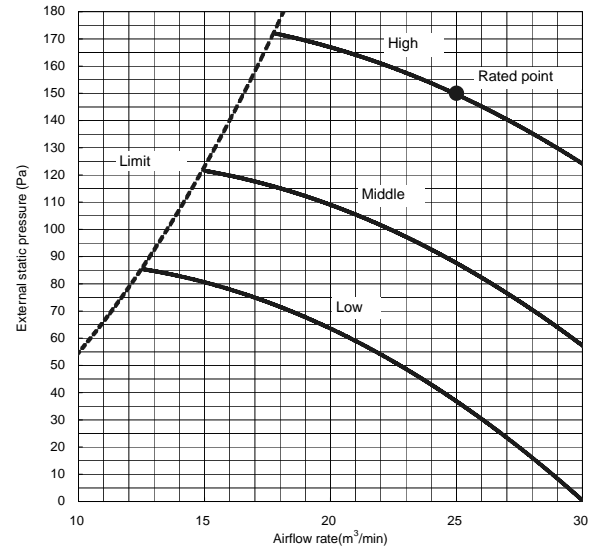

PEAD-M71JA(L)

(External static pressure 70Pa) 220-240V 50Hz

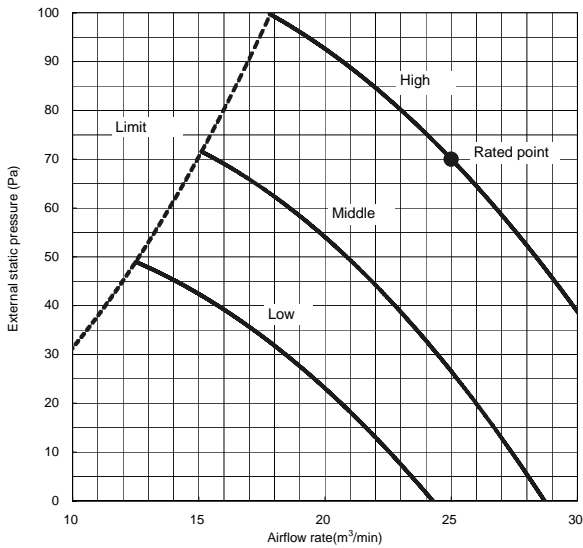

PEAD-M100JA(L)

(External static pressure 35Pa) 220-240V 50Hz

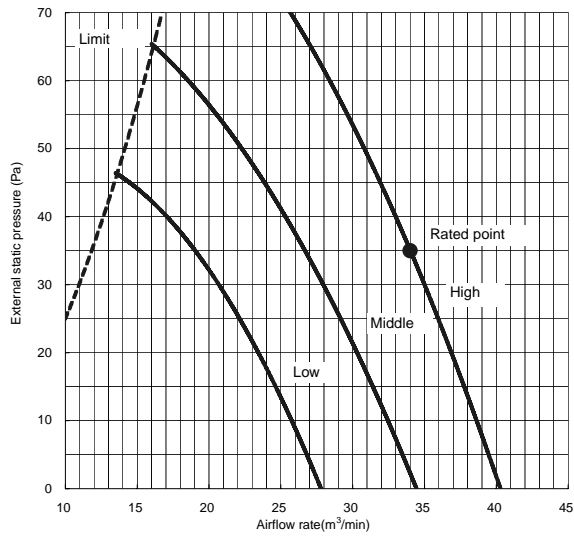

PEAD-M100JA(L)

(External static pressure 100Pa) 220-240V 50Hz

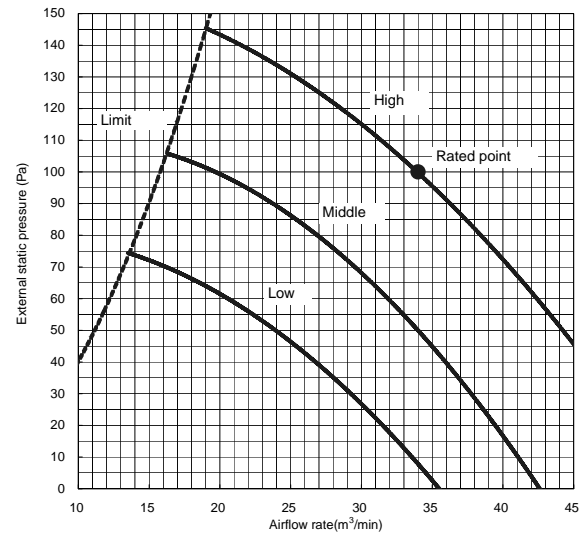

PEAD-M100JA(L)

(External static pressure 50Pa) 220-240V 50Hz

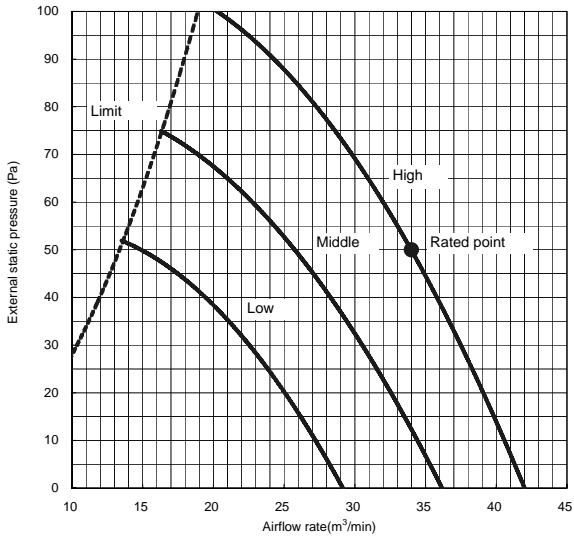

PEAD-M100JA(L)

(External static pressure 150Pa) 220-240V 50Hz

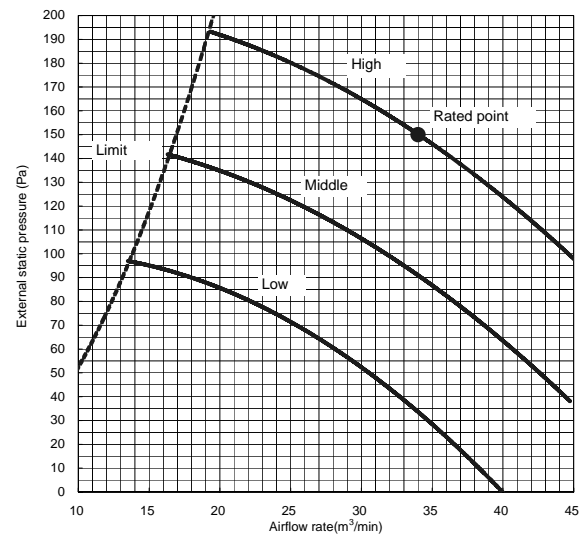

PEAD-M100JA(L)

(External static pressure 70Pa) 220-240V 50Hz

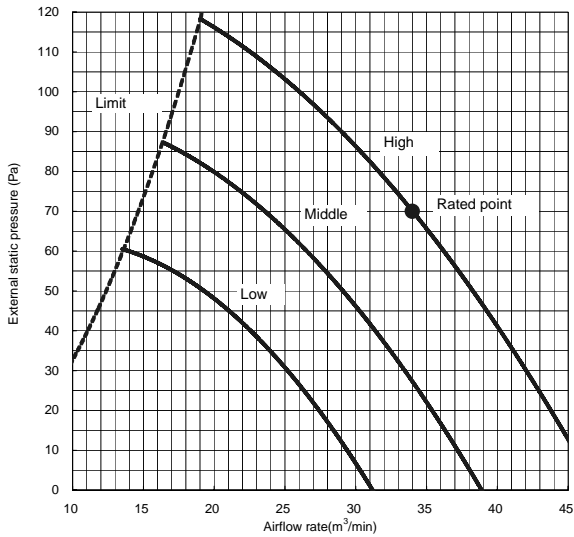

PEAD-M125JA(L)

(External static pressure 35Pa) 220-240V 50Hz

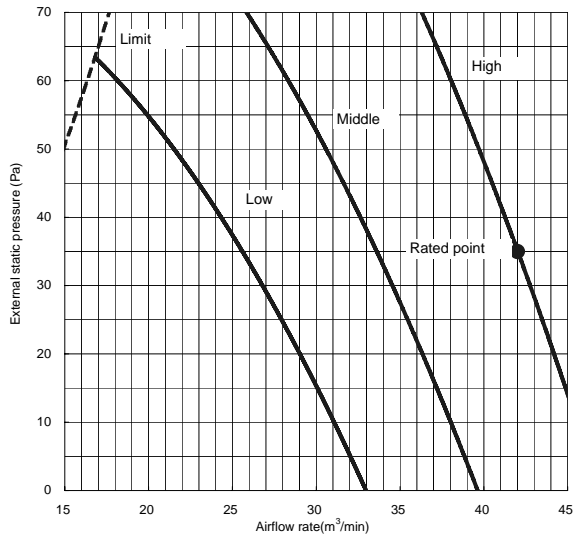

PEAD-M125JA(L)

(External static pressure 100Pa) 220-240V 50Hz

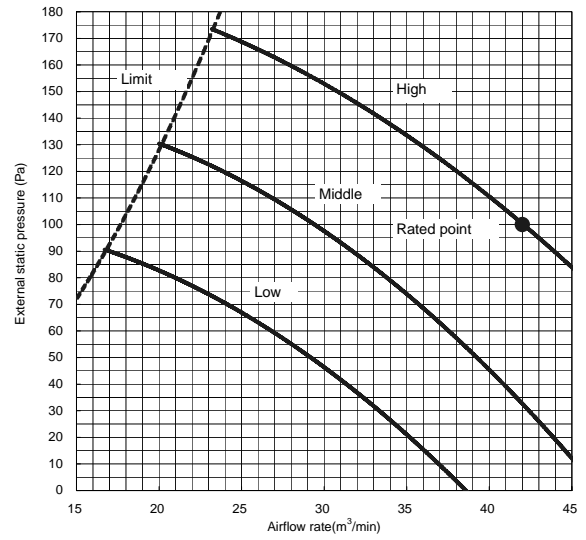

PEAD-M125JA(L)

(External static pressure 50Pa) 220-240V 50Hz

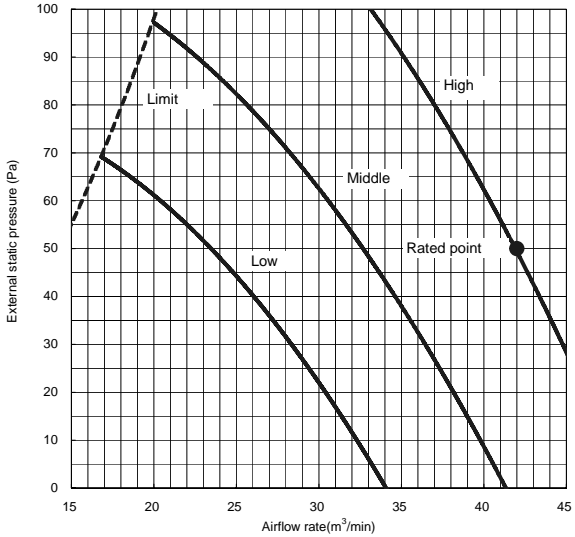

PEAD-M125JA(L)

(External static pressure 150Pa) 220-240V 50Hz

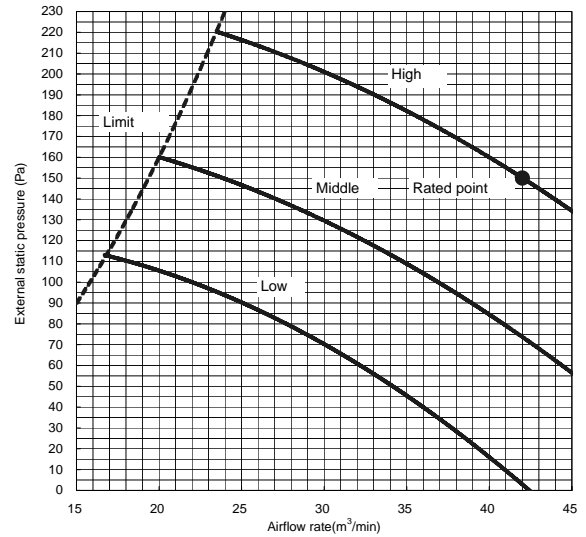

PEAD-M125JA(L)

(External static pressure 70Pa) 220-240V 50Hz

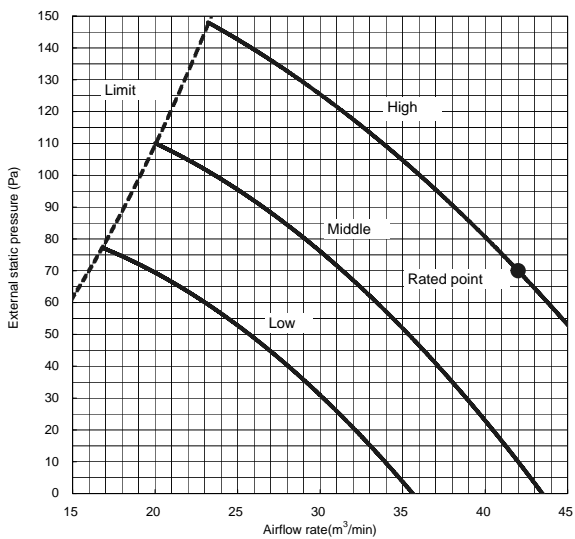

PEAD-M140JA(L)

(External static pressure 35Pa) 220-240V 50Hz

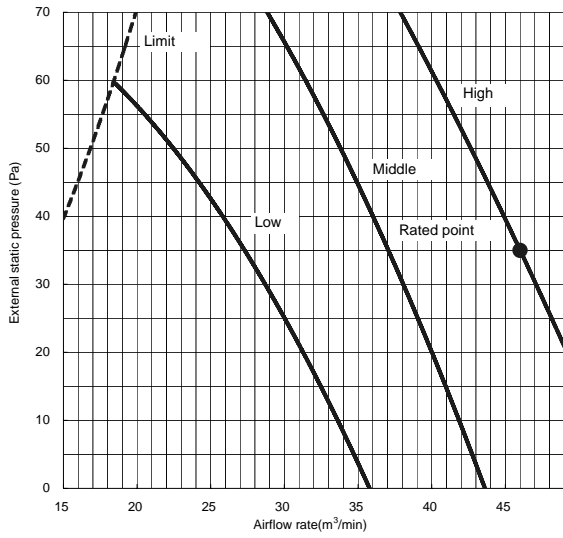

PEAD-M140JA(L)

(External static pressure 100Pa) 220-240V 50Hz

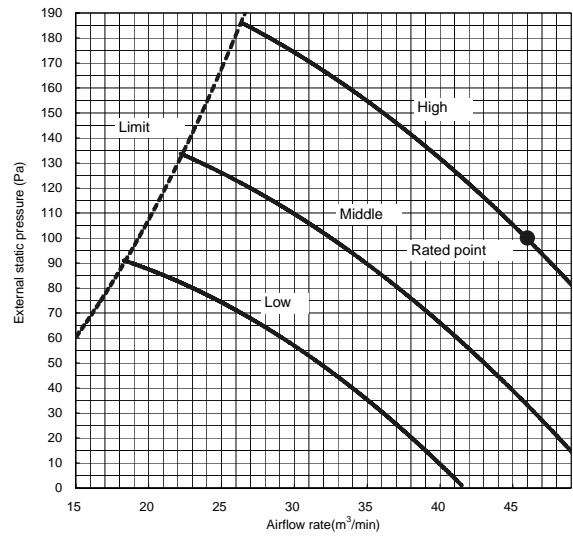

PEAD-M140JA(L)

(External static pressure 50Pa) 220-240V 50Hz

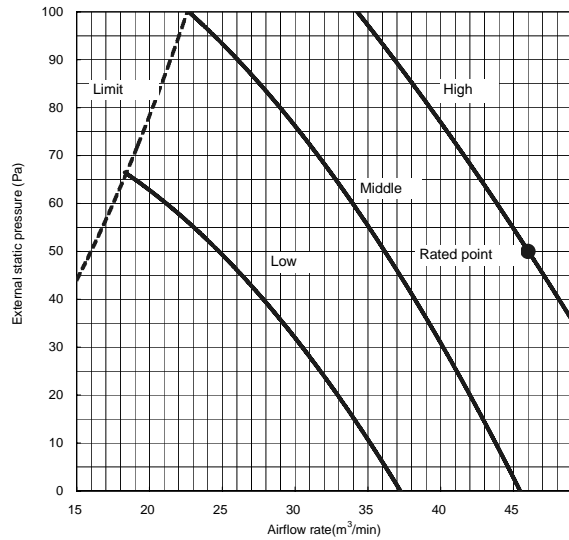

PEAD-M140JA(L)

(External static pressure 150Pa) 220-240V 50Hz

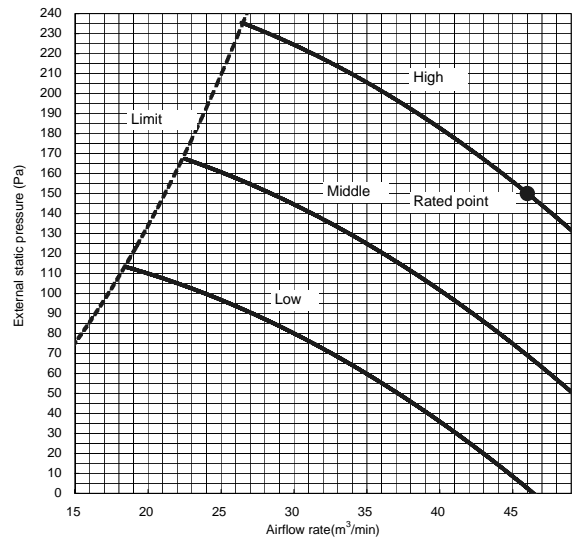

PEAD-M140JA(L)

(External static pressure 70Pa) 220-240V 50Hz

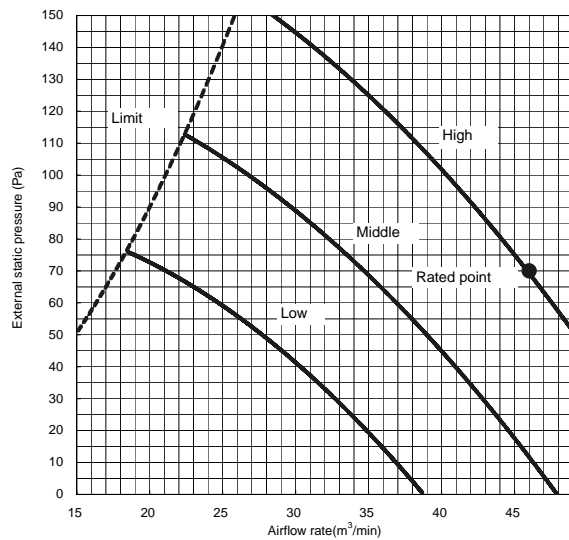

5

SOUND PRESSURE LEVELS

5-1. Sound pressure level Ceiling concealed

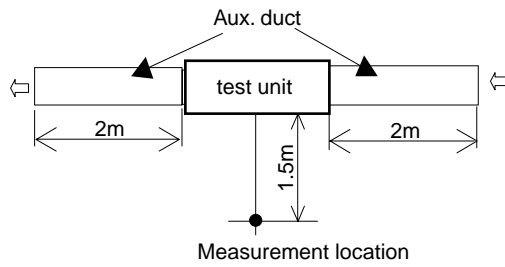

5-2. NC curves

PEAD-M35JA(L)

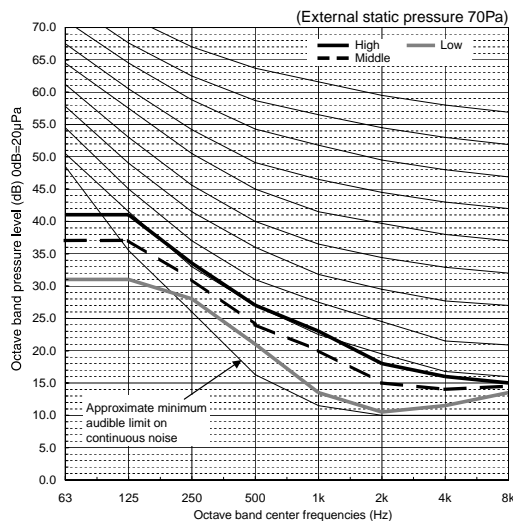
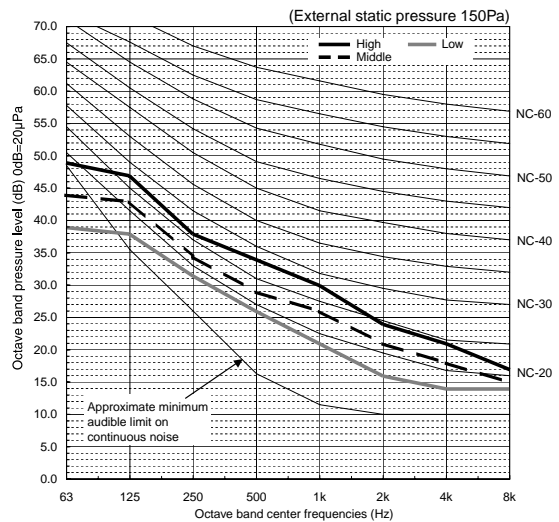
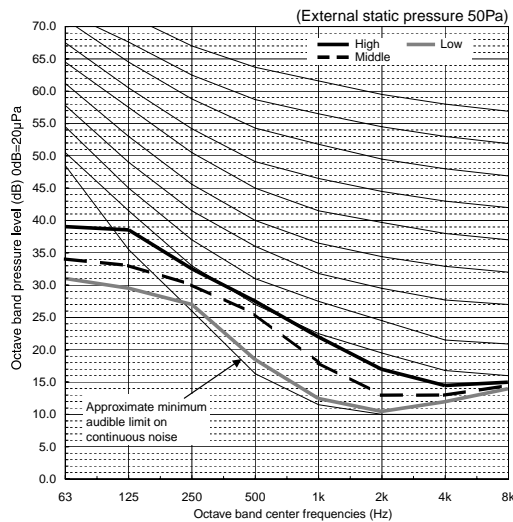
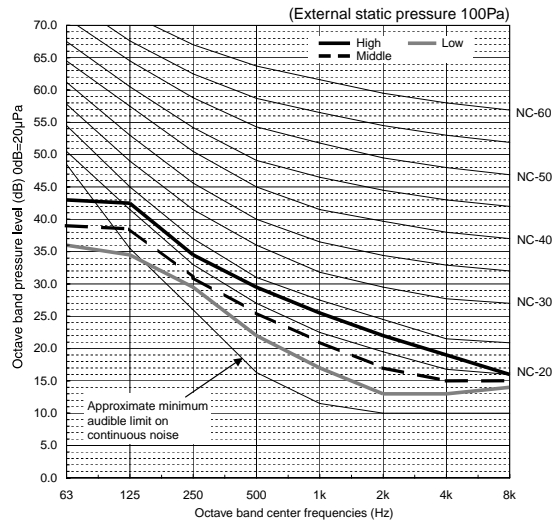
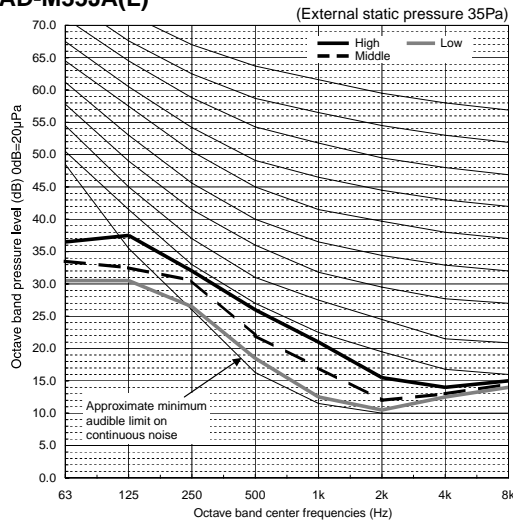

PEAD-M50JA(L)

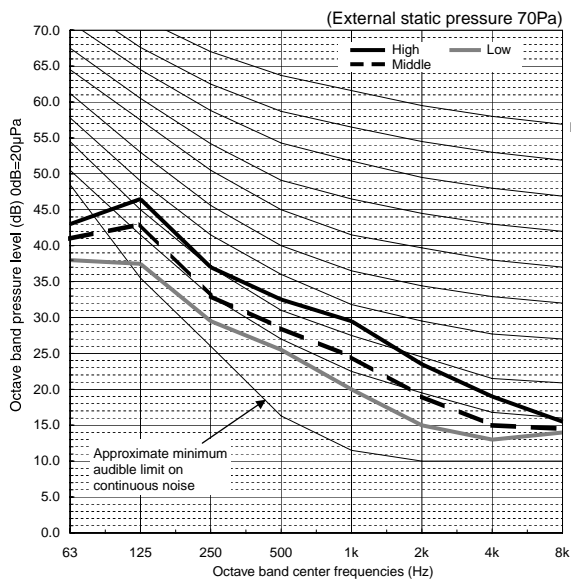
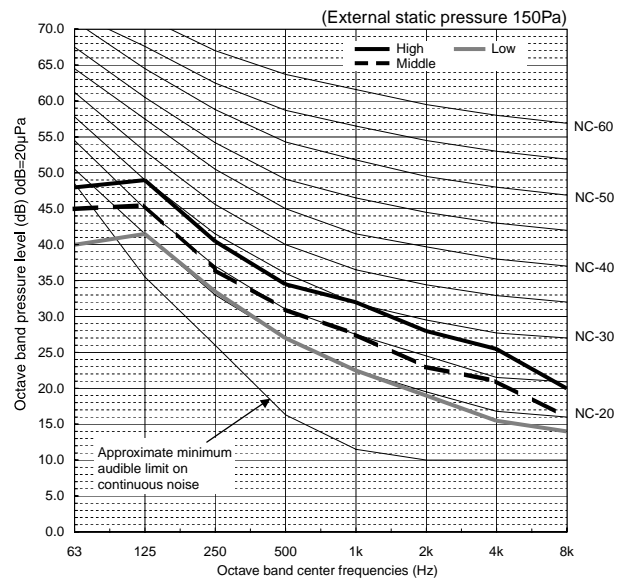
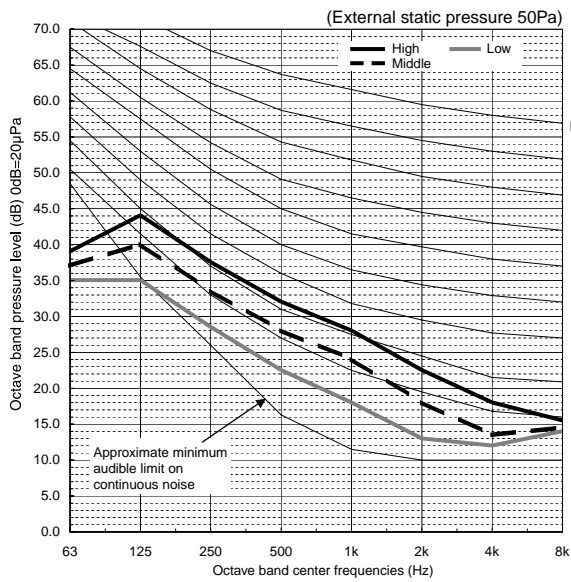
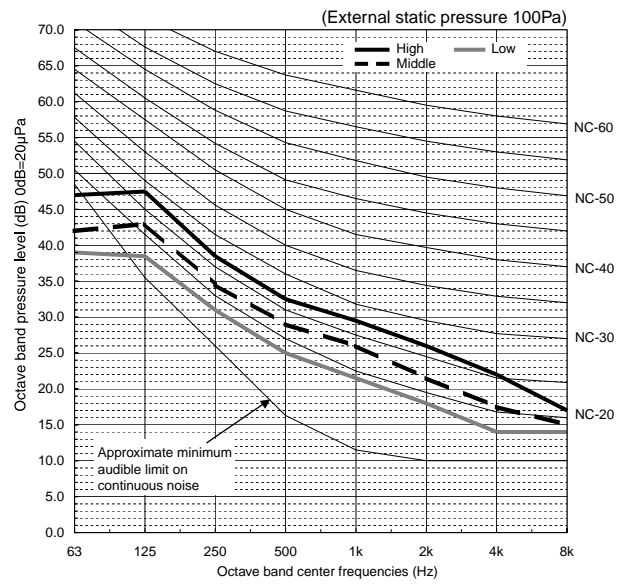
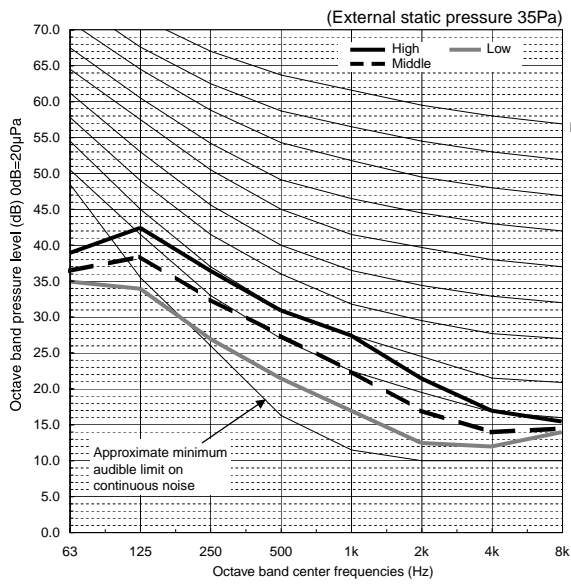

PEAD-M60JA(L)

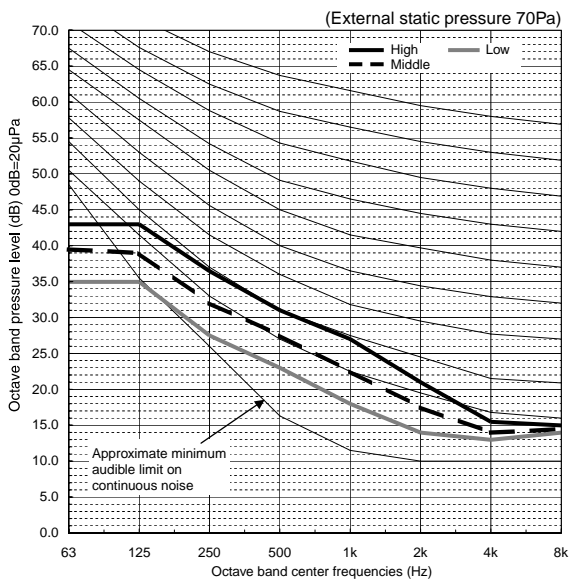
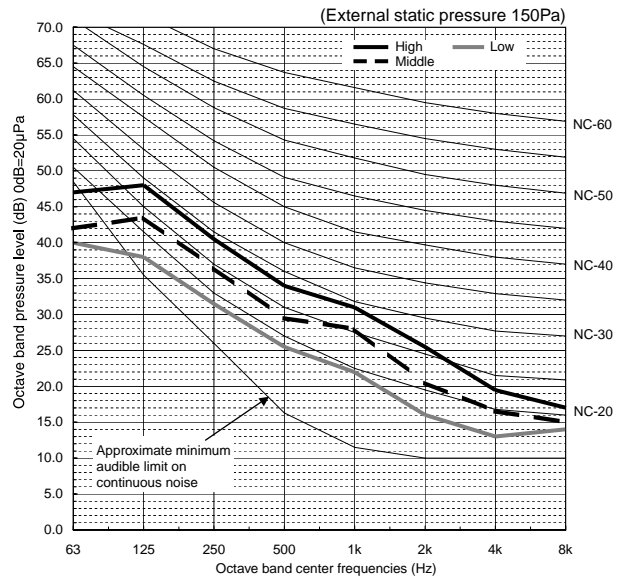
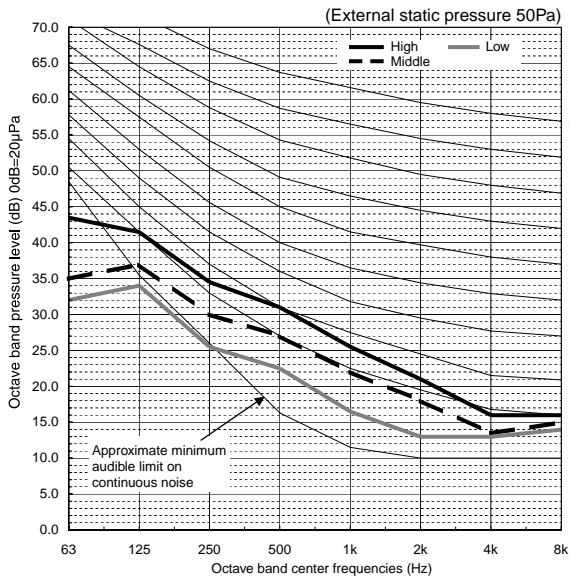
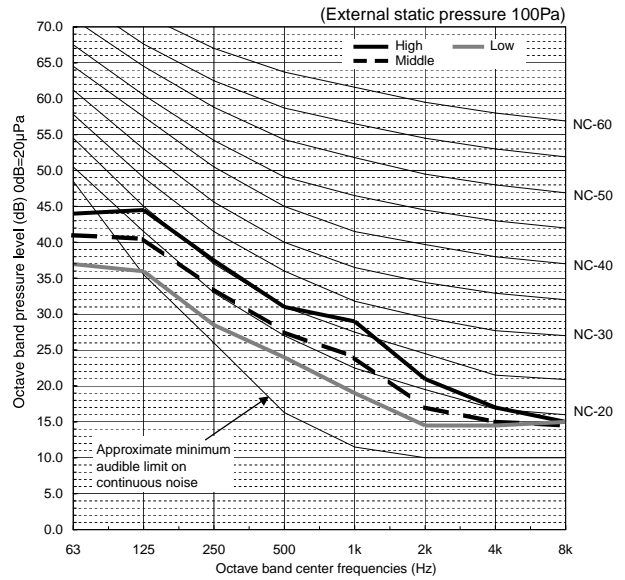
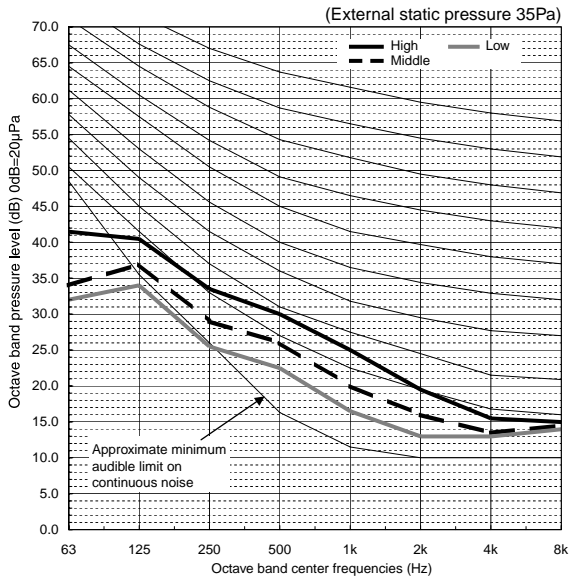

PEAD-M71JA(L)

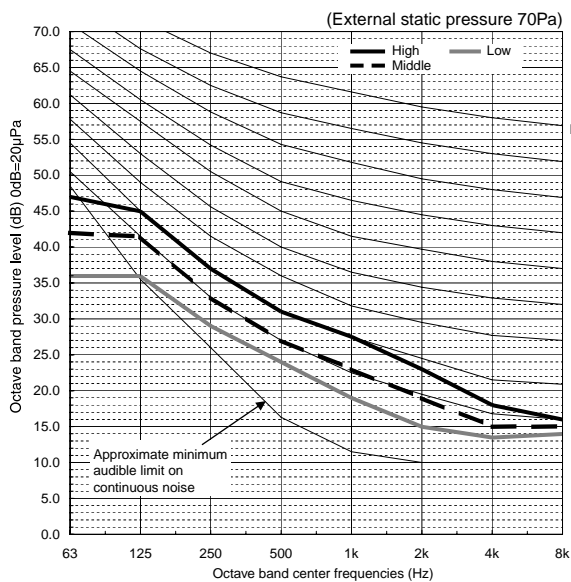
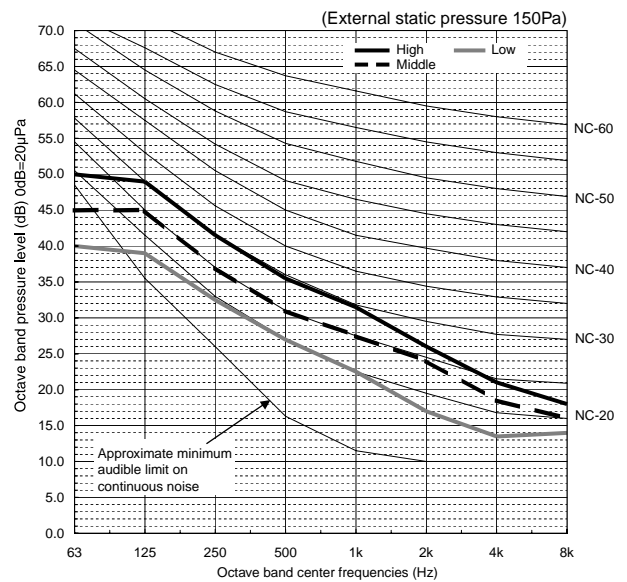
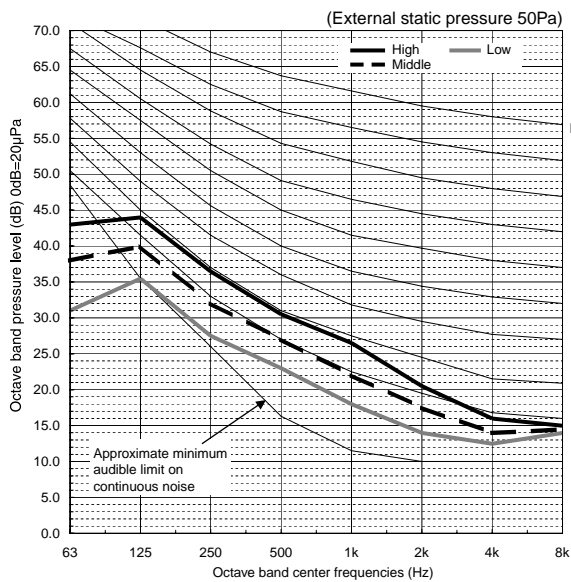
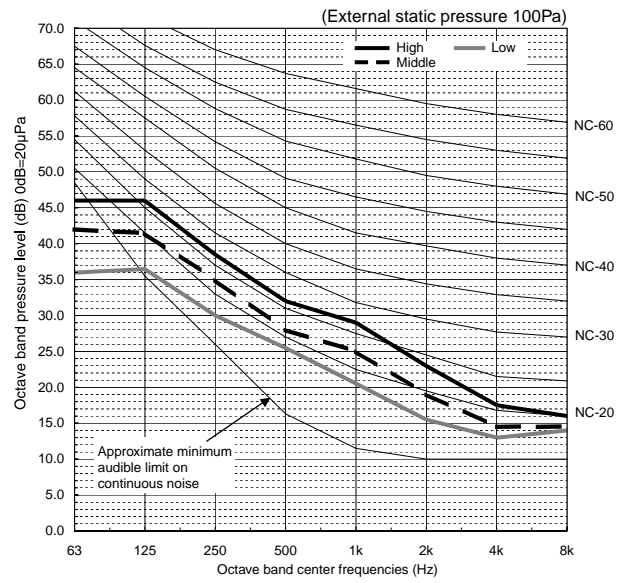
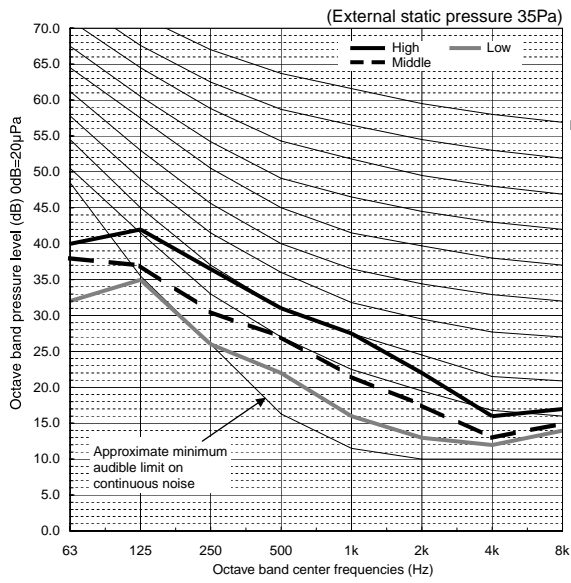

PEAD-M100JA(L)

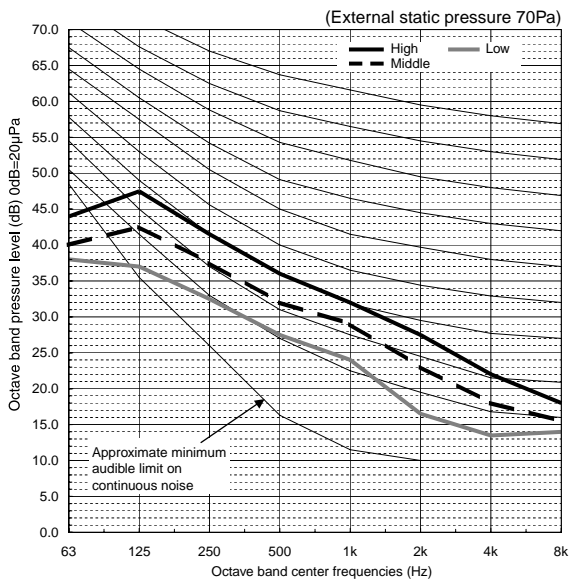
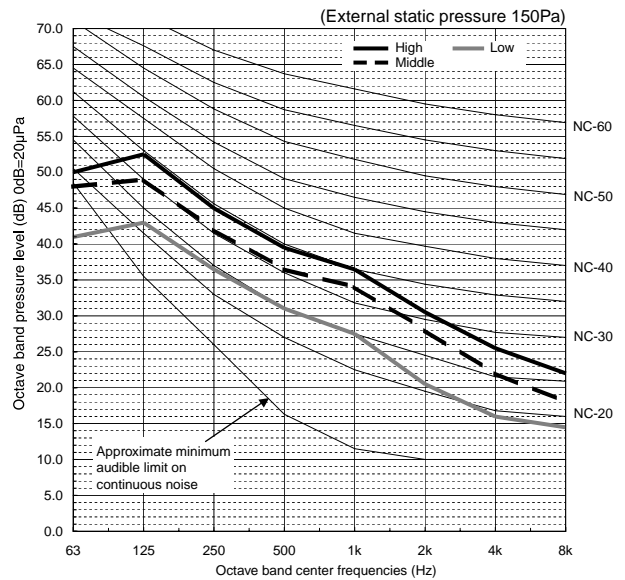
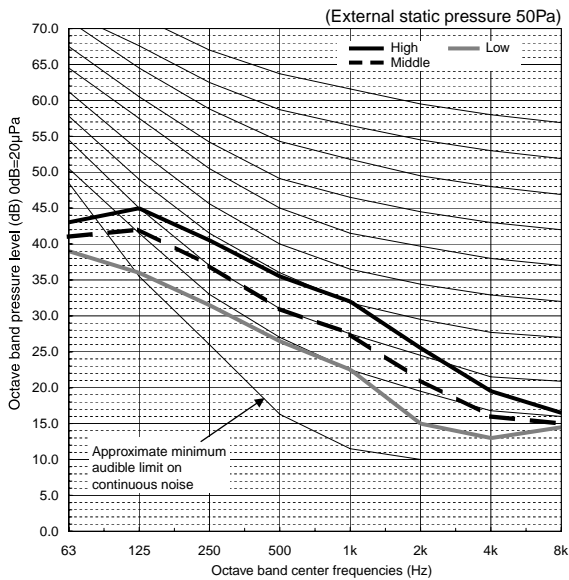
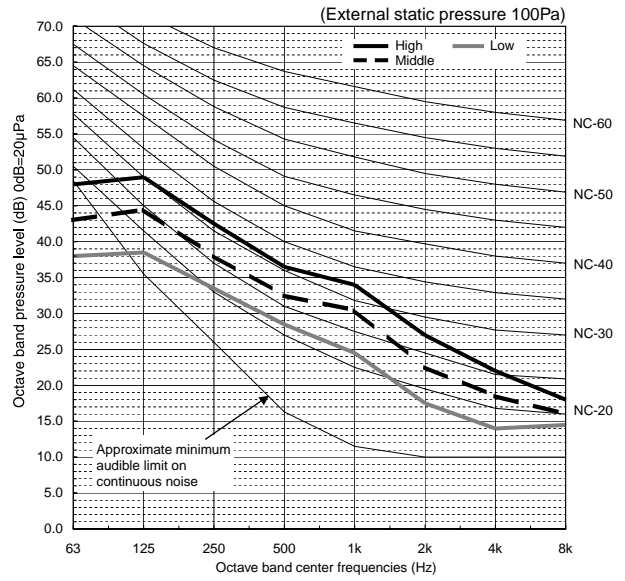
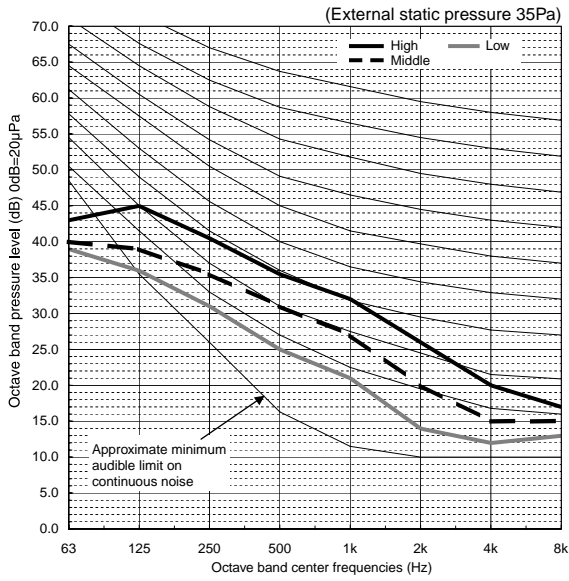

PEAD-M125JA(L)

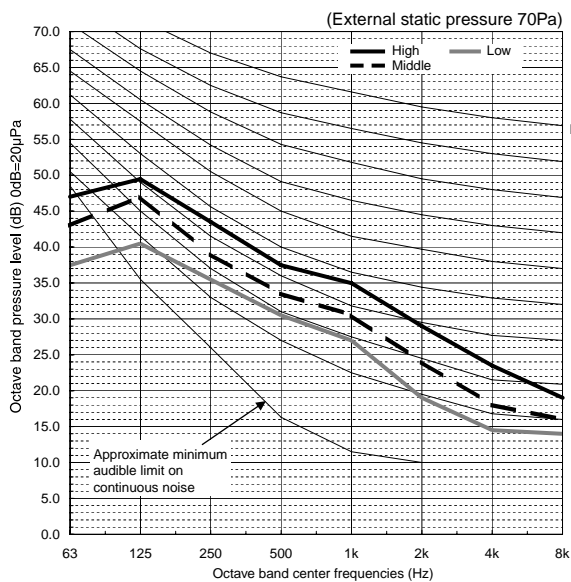
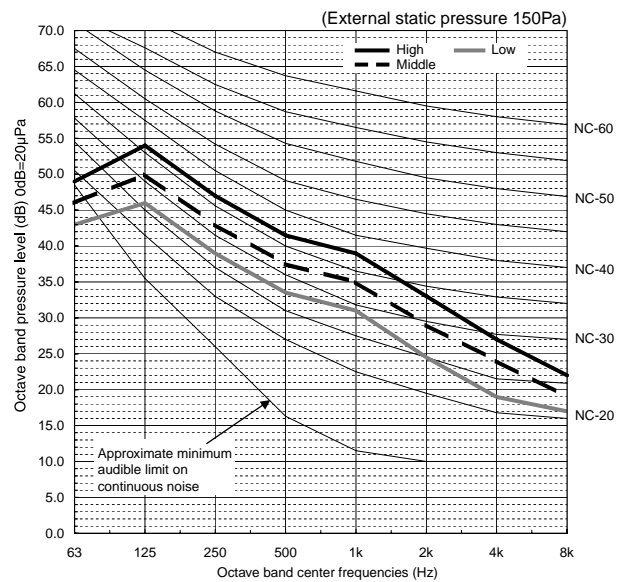
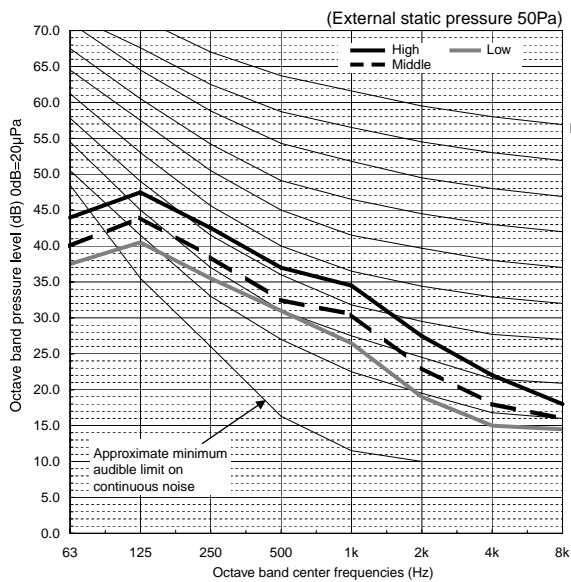
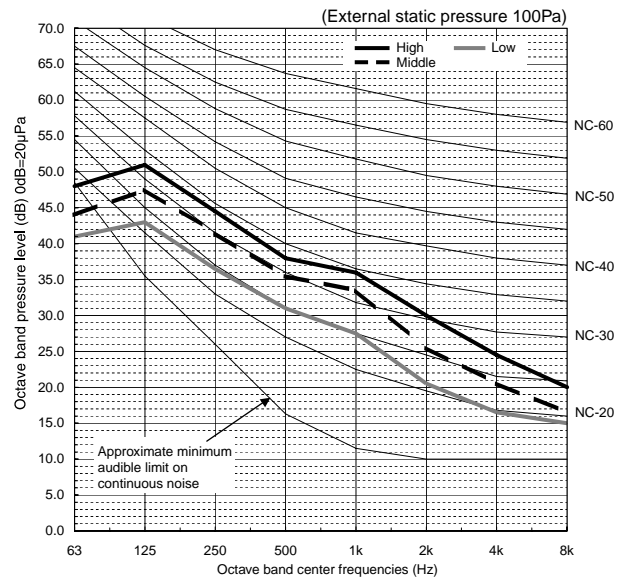
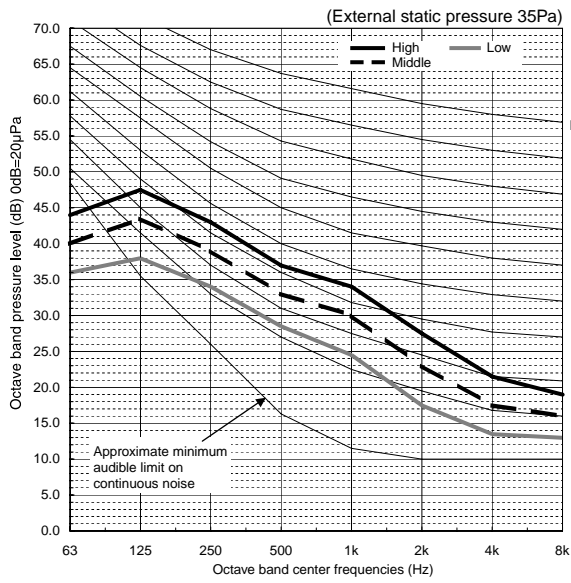

PEAD-M140JA(L)

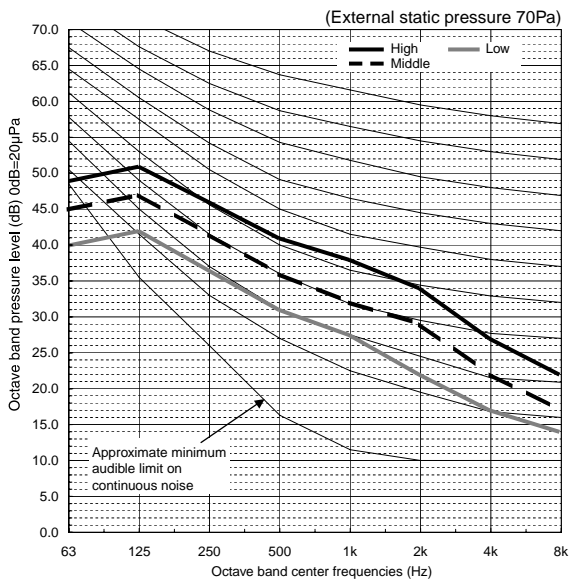
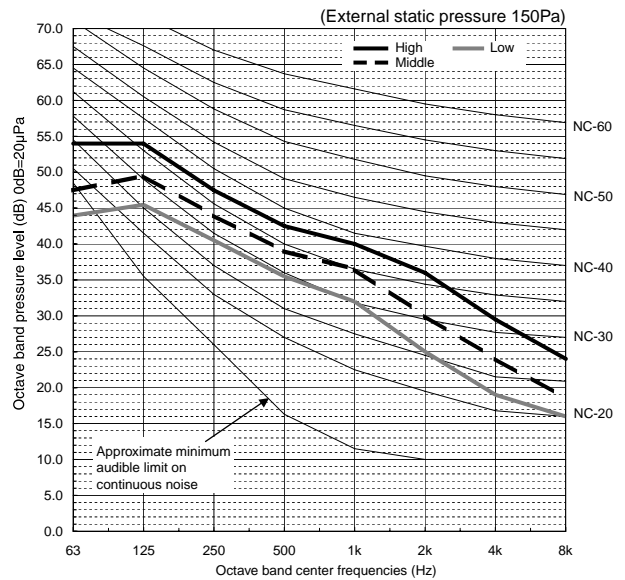
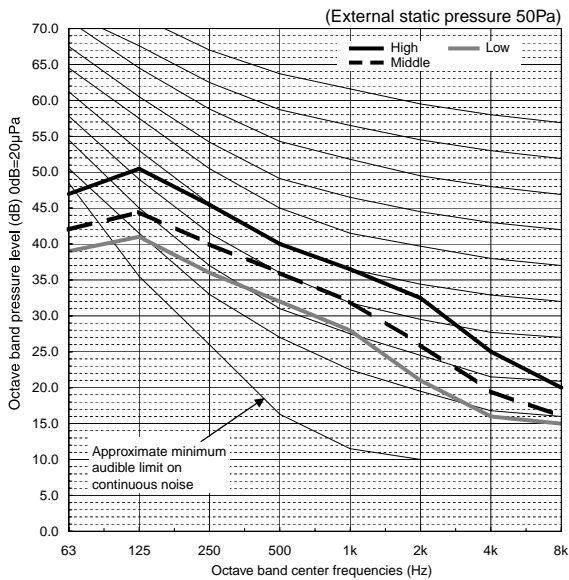
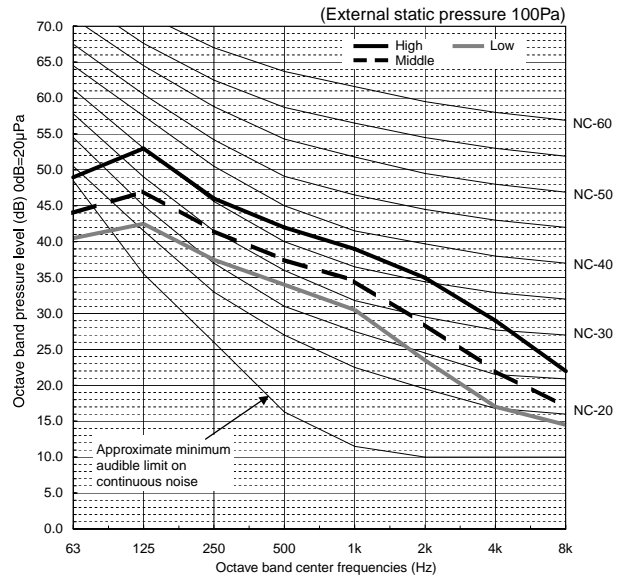
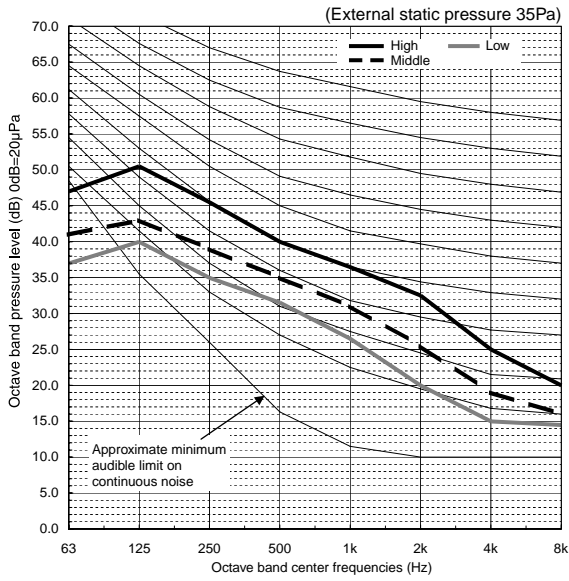

6

OUTLINES & DIMENSIONS

INDOOR UNIT

PEAD-M35, 50, 60, 71, 100, 125, 140JA

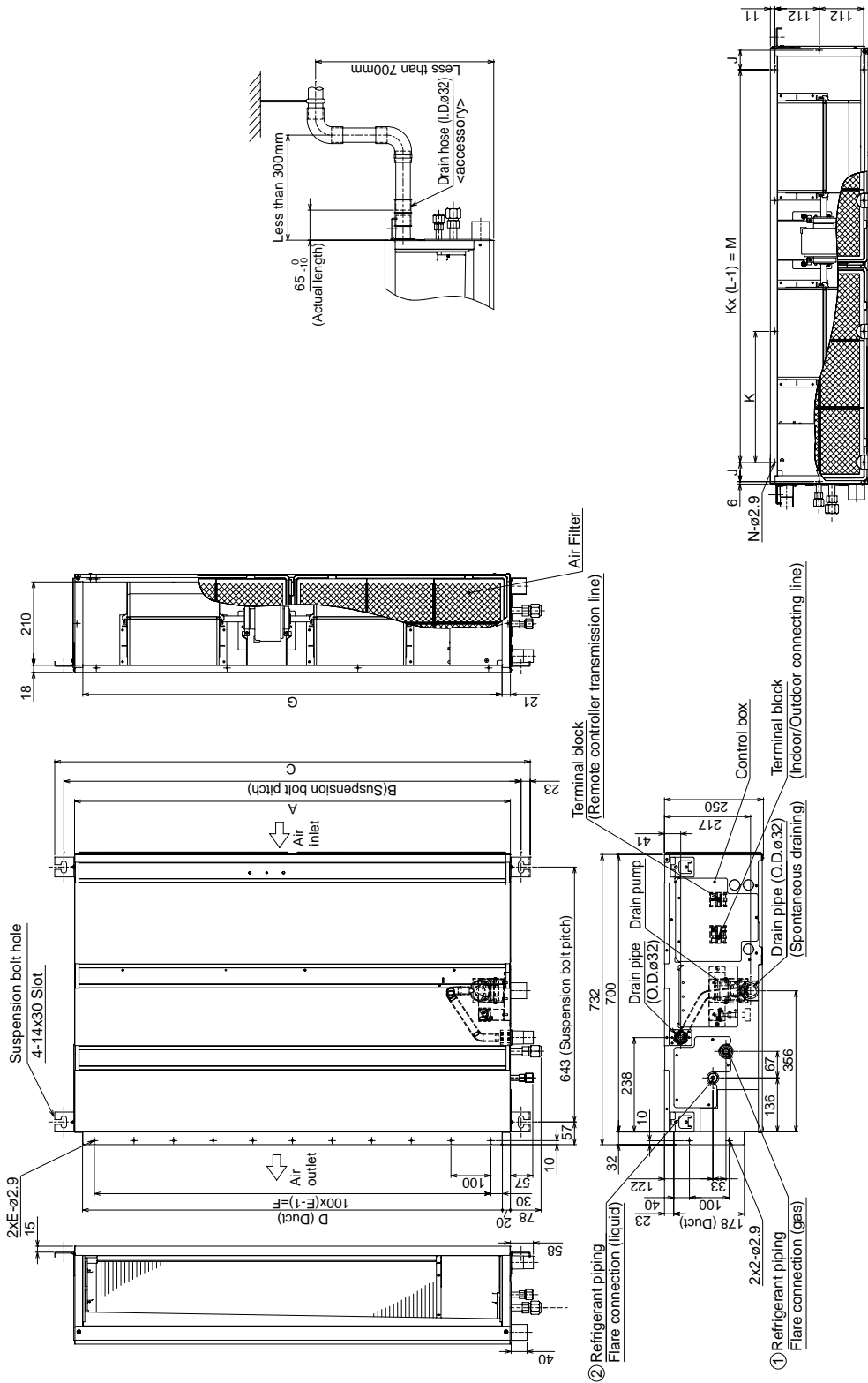

*Setting at shipment

Model	A	B	C	D	E	F	G	H	J	K	L	M	N	① Gas pipe		② Liquid pipe	
														ø12.7	ø15.88	ø9.35	ø9.52
PEAD-M35, 50JA	900	954	1000	860	9	800	838	1000	54	260	4	780	10	10	ø12.7	ø9.35	Outdoor unit (SUZ): ø6.35 Outdoor unit (other): ø9.52
PEAD-M60JA	1100	1154	1200	1060	11	1000	1058	1200	49	330	4	990	10	10	ø15.88	ø9.52	
PEAD-M71JA	1400	1454	1500	1360	14	1300	1358	1500	54	320	5	1280	12	12	ø15.88	ø9.52	
PEAD-M100, 125JA	1600	1654	1700	1560	16	1500	1558	1700	54	370	5	1480	12	12	ø15.88	ø9.52	

- NOTE
1. Use M10 screw for the Suspension bolt (field supply).
 2. Keep the service space for the maintenance at the bottom.
 3. This chart indicates for PEAD-M60-71-100-125-140JA models, which have 2 fans. PEAD-M35-50JA models have 1 fan.
 4. In case of the inlet duct is used, remove the air filter (supply with the unit), then install the filter (field supply) at suction side.

PEAD-M35, 50, 60, 71, 100, 125, 140JAL

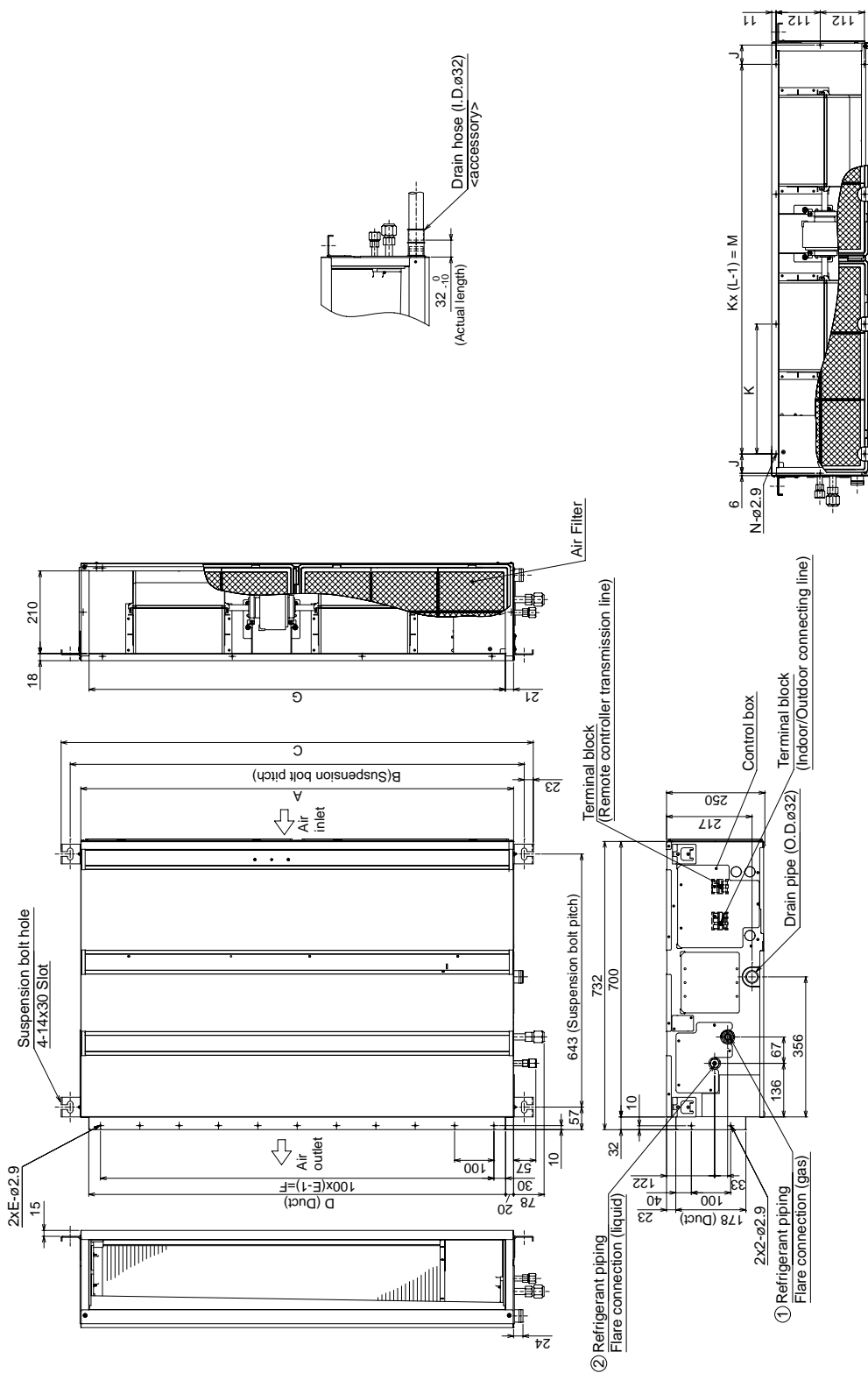

*Setting at shipment

Model	A	B	C	D	E	F	G	H	J	K	L	M	N	① Gas pipe	② Liquid pipe
PEAD-M35, 50JAL	900	954	1000	860	9	800	858	1000	54	260	4	780	10	φ12.7	φ6.35
PEAD-M60JAL	1100	1154	1200	1060	11	1000	1058	1200	49	330	4	990	10	φ15.88	Outdoor unit (SUZ); φ6.35 Outdoor unit (other); φ9.52
PEAD-M71JAL	1400	1454	1500	1360	14	1300	1358	1500	54	320	5	1280	12		
PEAD-M100, 125JAL	1600	1654	1700	1560	16	1500	1558	1700	54	370	5	1480	12		φ9.52

- NOTE
1. Use M10 screw for the Suspension bolt (field supply).
 2. Keep the service space for the maintenance at the bottom.
 3. This chart indicates for PEAD-M60-71-100-125-140JAL models, which have 2 fans. PEAD-M35-50JAL models have 1 fan.
 4. In case of the inlet duct is used, remove the air filter (supply with the unit), then install the filter (field supply) at suction side.

PEAD-M35, 50, 60, 71, 100, 125, 140JA(L)

Secure enough access space to allow for the maintenance, inspection, and replacement of the motor, fan, drain pump, heat exchanger, and electric box in one of the following ways.

Select an installation site for the indoor unit so that its maintenance access space will not be obstructed by beams or other objects.

(1) When a space of 300 mm or more is available below the unit between the unit and the ceiling (Fig. 1)

- Create access door 1 and 2 (450 x 450 mm each) as shown in Fig. 2.

(Access door 2 is not required if enough space is available below the unit for a maintenance worker to work in.)

(2) When a space of less than 300 mm is available below the unit between the unit and the ceiling (At least 20 mm of space should be left below the unit as shown in Fig. 3.)

- Create access door 1 diagonally below the electric box and access door 3 below the unit as shown in Fig. 4.

or

- Create access door 4 below the electric box and the unit as shown in Fig. 5.

Unit: mm

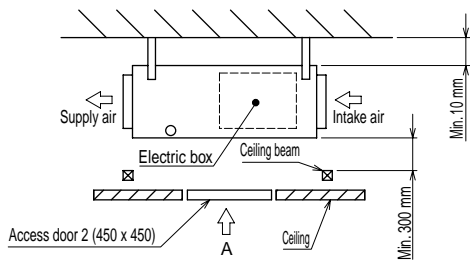

Fig. 1

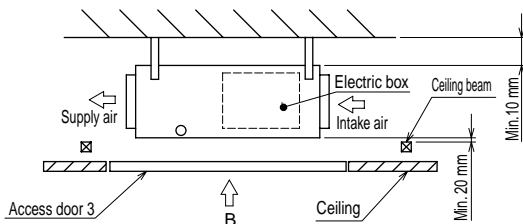

Fig. 3

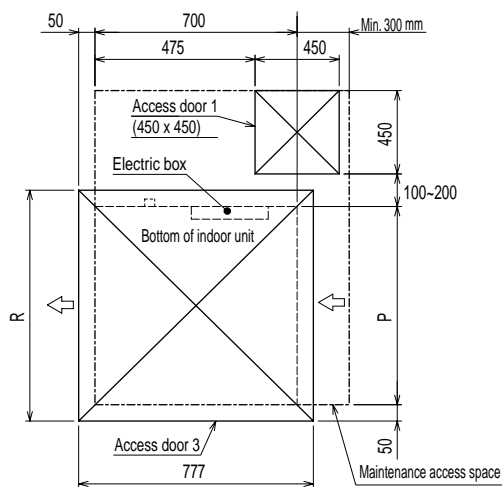

Fig. 4 (Viewed from the direction of the arrow B)

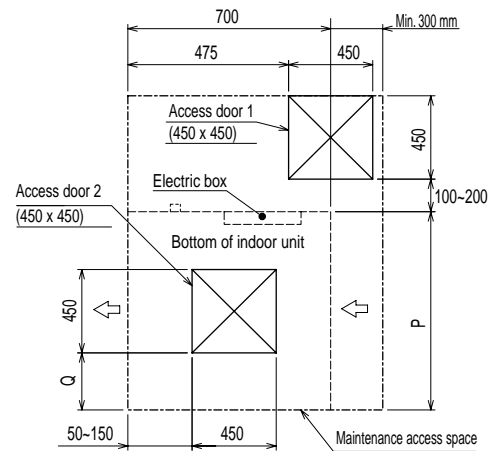

Fig. 2 (Viewed from the direction of the arrow A)

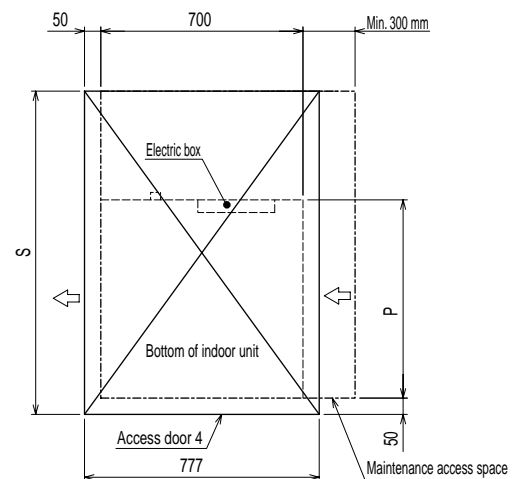

Fig. 5 (Viewed from the direction of the arrow B)

Model	P	Q	R	S
PEAD-M35, 50JA(L)	900	150~250	1000	1500
PEAD-M60, 71JA(L)	1100	250~350	1200	1700
PEAD-M100, 125JA(L)	1400	400~500	1500	2000
PEAD-M140JA(L)	1600	500~600	1700	2200

7

WIRING DIAGRAM

PEAD-M35, 50, 60, 71, 100, 125, 140JA(L)

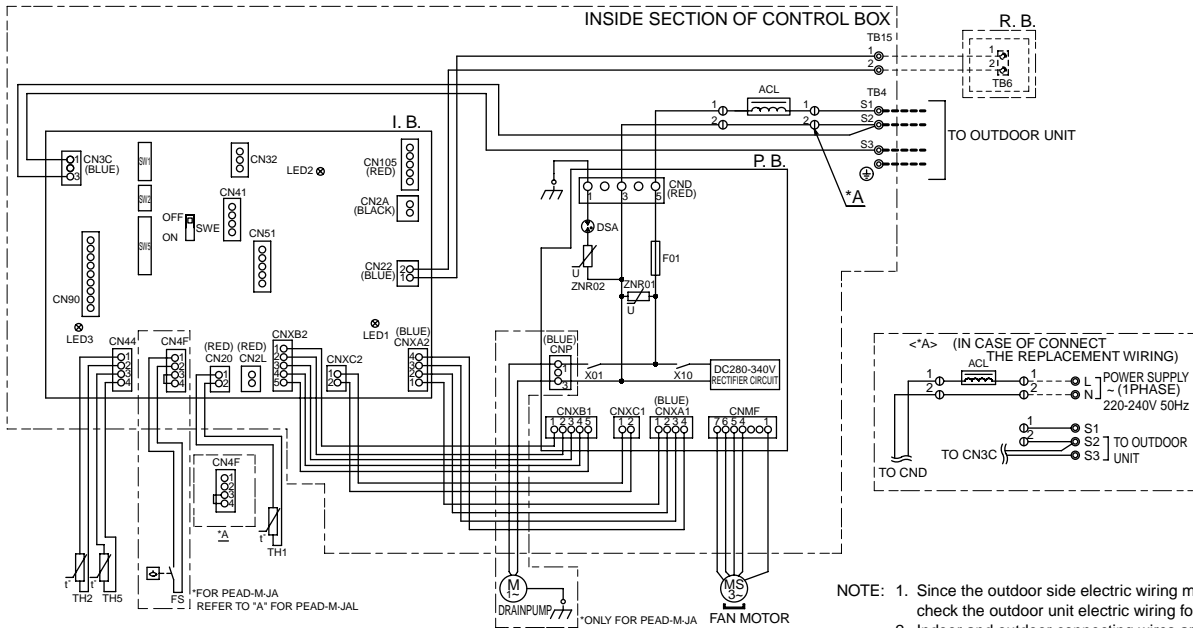

- NOTE: 1. Since the outdoor side electric wiring may change, be sure to check the outdoor unit electric wiring for servicing.
 2. Indoor and outdoor connecting wires are made with polarities, make wiring matching terminal numbers (S1, S2, S3).
 3. Symbols used in wiring diagram above are,

⊙ : CONNECTOR
 ⊕ : TERMINAL BLOCK
 - - - - - (HEAVY DOTTED LINE): FIELD WIRING
 (THIN DOTTED LINE): OPTIONAL PARTS

SYMBOL EXPLANATION

SYMBOL	NAME	SYMBOL	NAME	SYMBOL	NAME
I. B.	INDOOR CONTROLLER BOARD	I. B.	INDOOR CONTROLLER BOARD	TH1	INTAKE AIR TEMP. THERMISTOR
CN2A	CONNECTOR (0-10V ANALOG INPUT)	SW1	SWITCH (FOR MODE SELECTION)	TH2	PIPE TEMP. THERMISTOR/LIQUID
CN2L	CONNECTOR (LOSSNAY)	SW2	SWITCH (FOR CAPACITY CODE)	TH5	COND./EVA. TEMP. THERMISTOR
CN32	CONNECTOR (REMOTE SWITCH)	SW5	SWITCH (FOR MODEL SELECTION)	ACL	AC REACTOR (POWER FACTOR IMPROVEMENT)
CN41	CONNECTOR (HA TERMINAL-A)	SWE	CONNECTOR (EMERGENCY OPERATION)	FS	FLOAT SWITCH
CN51	CONNECTOR (CENTRALLY CONTROL)	P. B.	POWER SUPPLY BOARD	TB4	TERMINAL BLOCK (INDOOR/OUTDOOR CONNECTING LINE)
CN90	CONNECTOR (WIRELESS)	F01	FUSE AC250V 6.3A	TB15	TERMINAL BLOCK (REMOTE CONTROLLER TRANSMISSION LINE)
CN105	CONNECTOR (IT TERMINAL)	ZNR01.02	VARISTOR	R. B.	REMOTE CONTROLLER BOARD
LED1	LED (POWER SUPPLY)	DSA	ARRESTER	TB6	TERMINAL BLOCK (REMOTE CONTROLLER TRANSMISSION LINE)
LED2	LED (REMOTE CONTROLLER SUPPLY)	X01	AUX. RELAY		
LED3	LED (TRANSMISSION INDOOR-OUTDOOR)	X10	AUX. RELAY		

8

REFRIGERANT SYSTEM DIAGRAM

PEAD-M35, 50, 60, 71, 100, 125, 140JA(L)

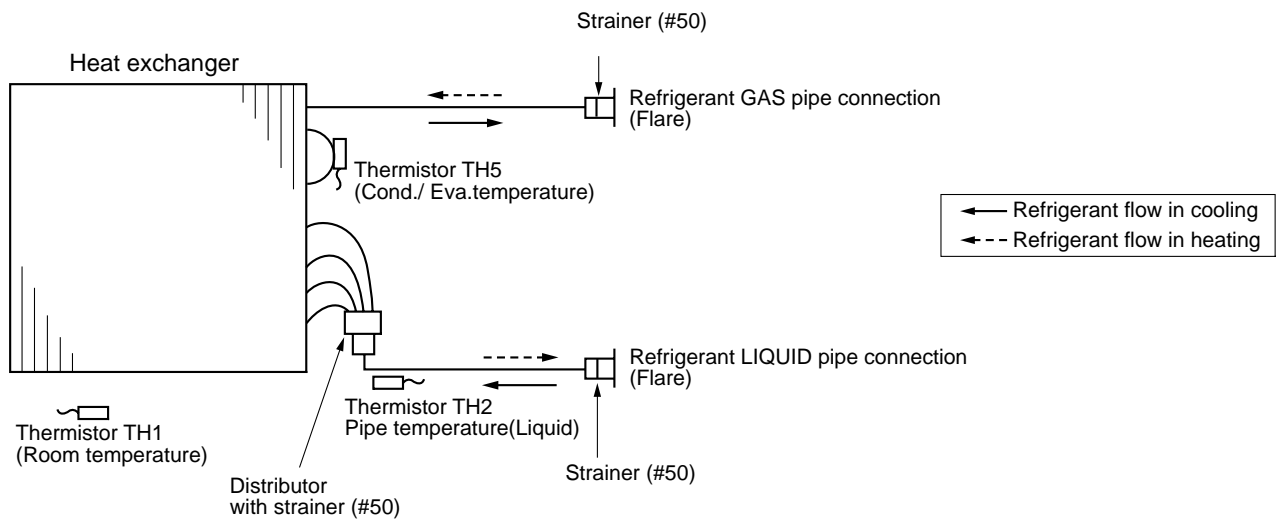

Mr. SLIM™

MITSUBISHI ELECTRIC CORPORATION

www.MitsubishiElectric.com
