

Copyright HCS Essex Ltd  
Do not scale from this drawing. All dimensions to be checked on site prior to commencement of work. Check that this drawing is the latest revision, if in doubt ASK. This drawing is copyright, refer any discrepancy to HCS Essex Ltd Ltd. THIS PLAN HAS BEEN PREPARED FROM INFORMATION PROVIDED BY THE CLIENT AND FROM RECONNAISSANCE SURVEY PLANS AND AS SUCH CANNOT BE HELD UPON FOR ACCURACY OF SITE DIMENSIONS. The client is responsible for defining the boundaries of the site and for obtaining the necessary planning and other permissions. HCS Essex Ltd cannot be held responsible for subsequent land ownership disputes. © HCS Essex Ltd

**NOTES**

1. TO BE USED IN CONJUNCTION WITH THE EXISTING UTILITIES AND SERVICES.
2. ALL WORK TO BE COMPLETED TO THE SATISFACTION OF THE LOCAL AUTHORITY AND THE CLIENT.
3. ALL MATERIALS TO BE USED SHALL BE OF THE QUALITY AND TYPE SPECIFIED IN THE DRAWING.
4. ALL WORK SHALL BE COMPLETED WITHIN THE SPECIFIED TIME FRAME.
5. ALL WORK SHALL BE COMPLETED TO THE SATISFACTION OF THE LOCAL AUTHORITY AND THE CLIENT.
6. ALL WORK SHALL BE COMPLETED TO THE SATISFACTION OF THE LOCAL AUTHORITY AND THE CLIENT.
7. ALL WORK SHALL BE COMPLETED TO THE SATISFACTION OF THE LOCAL AUTHORITY AND THE CLIENT.
8. ALL WORK SHALL BE COMPLETED TO THE SATISFACTION OF THE LOCAL AUTHORITY AND THE CLIENT.
9. ALL WORK SHALL BE COMPLETED TO THE SATISFACTION OF THE LOCAL AUTHORITY AND THE CLIENT.
10. ALL WORK SHALL BE COMPLETED TO THE SATISFACTION OF THE LOCAL AUTHORITY AND THE CLIENT.

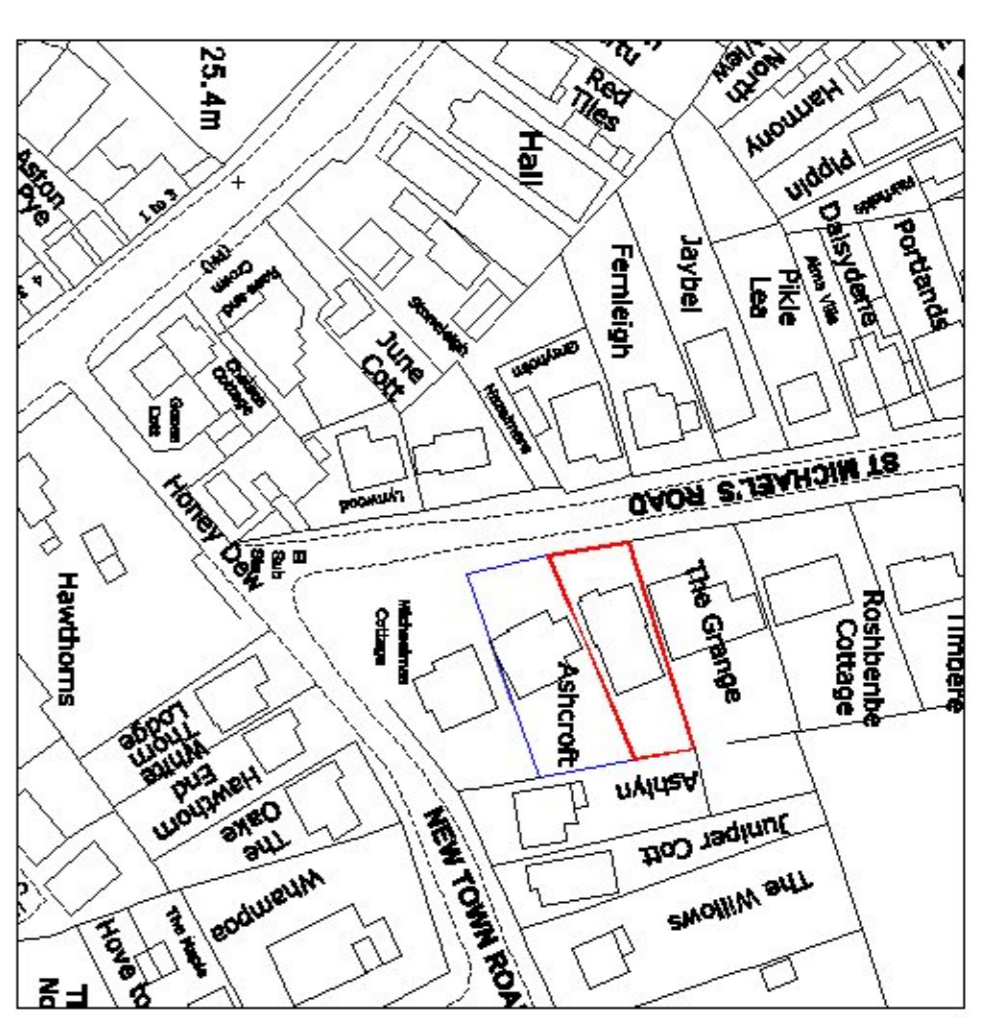

**Location Plan**  
1:1250

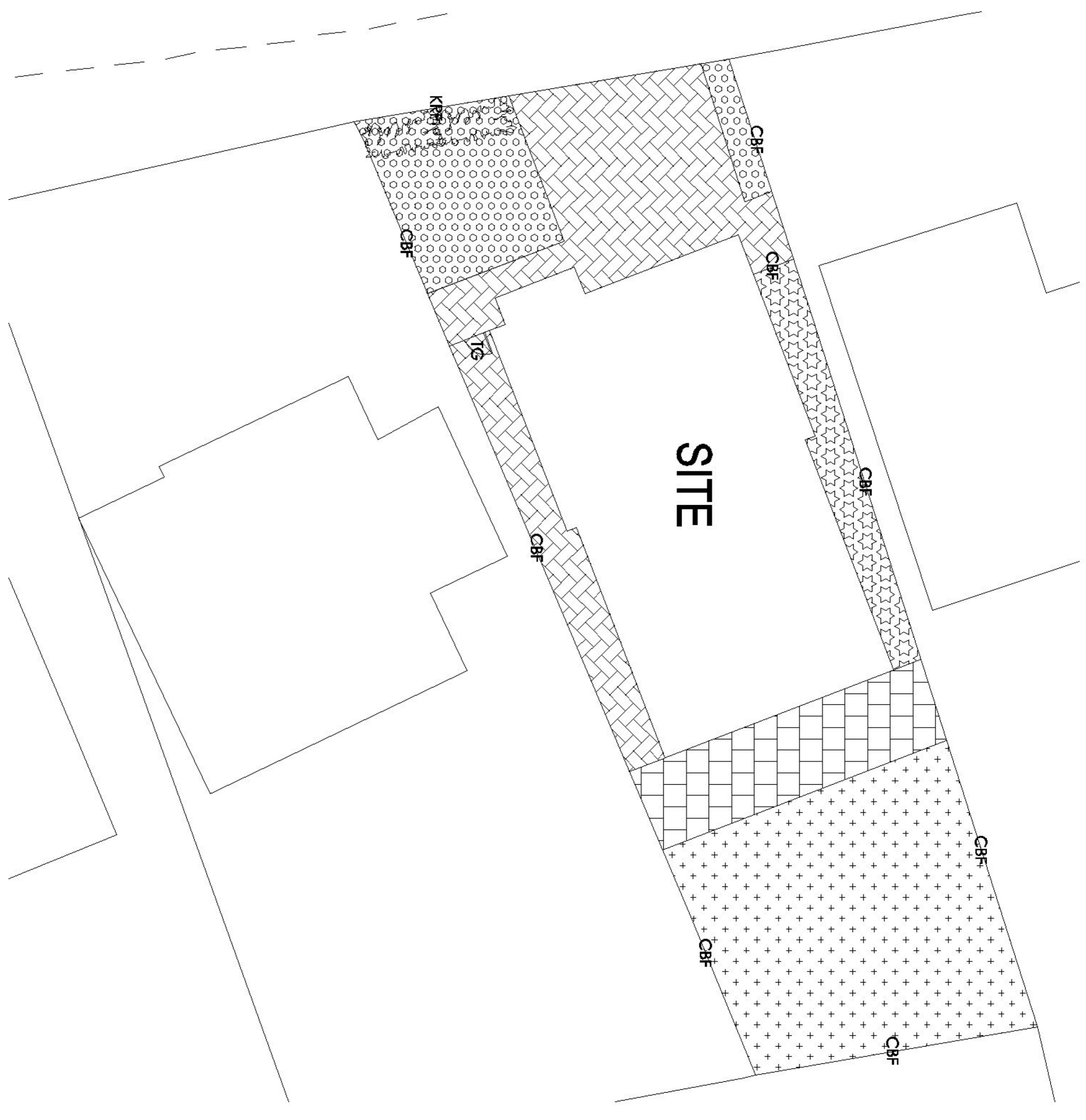

- Broadstone Drywayway 200x100mm Black Paving (Autumn)
- Broadstone Textured Paving 450x450mm Slabs (Dark Grey)
- End User Client Planting Areas
- Quality Turfed Amenity Areas
- 12-14mm Stone Dressing laid on geotextile membrane to aid natural drainage
- Specimen Tree - Native Crab Apple Malus x zumi 'GOLDEN HORNET'
- Native mixed hedging - 50% Quickthorn 10% Blackthorn 10% Dog Rose 10% Field Maple 10% Dogwood 10% Hazel (See Plan)
- Existing Native Hedging
- Existing Trees
- Timber Knee Rail Fence (See Detail Below)
- Close Boarded Fence (See Detail Below)
- Timber Panelled Fence 0.9 - 1.8m High
- Timber Gate (See Detail Below)

**Landscape / External Works Layout**  
Plan 1:100

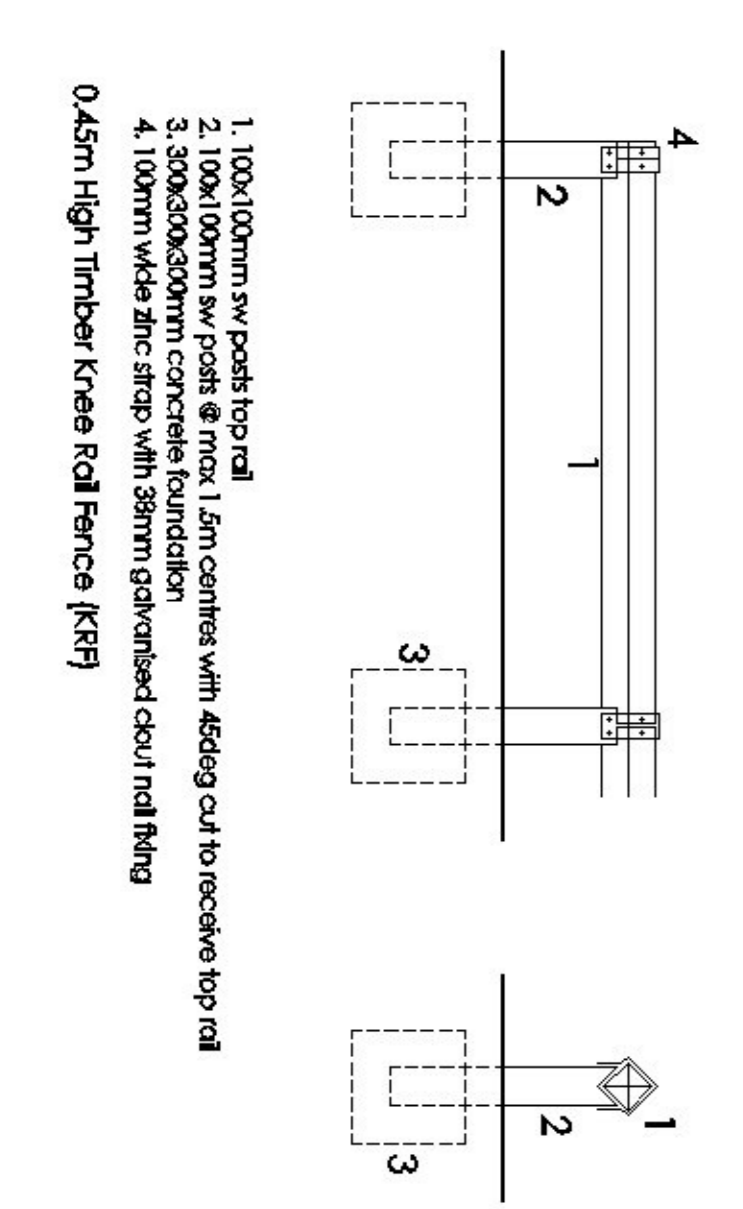
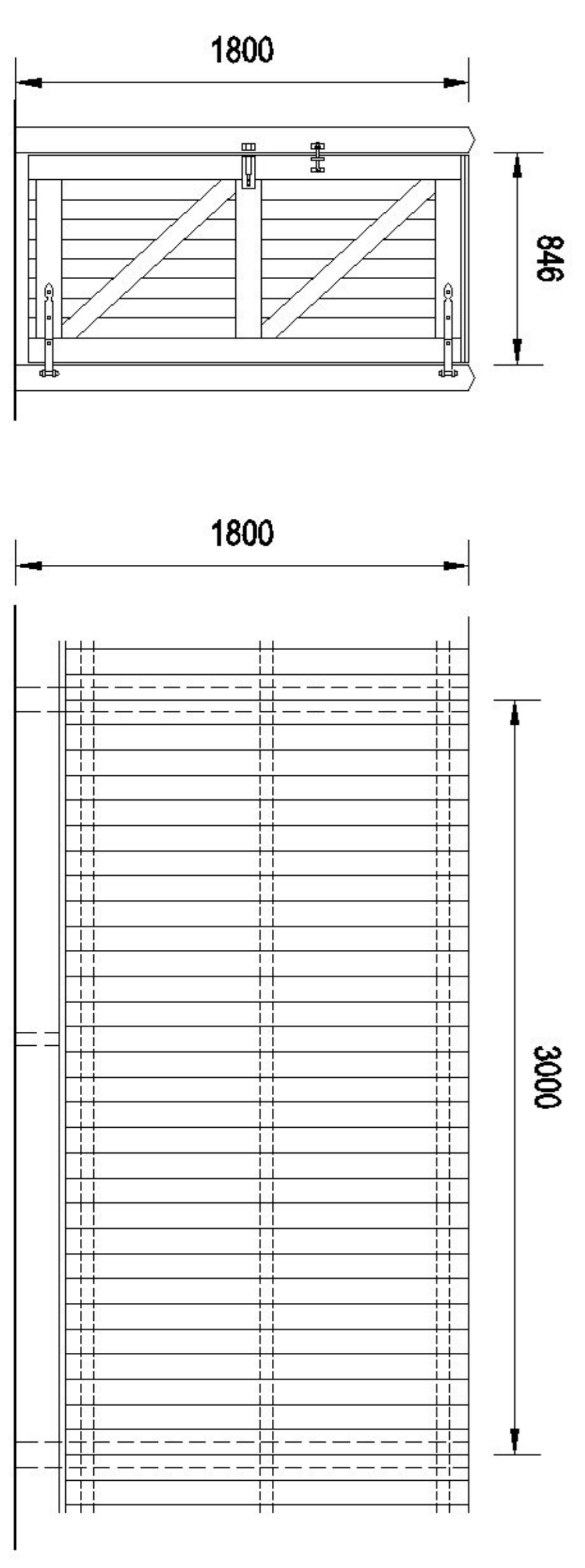
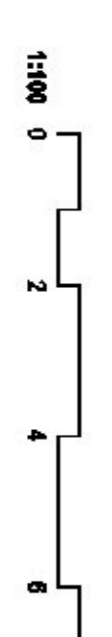

REV.	NO.	DATE	BY	CHKD

**HCS**

Unit 3  
Valley Barns  
Golden Lane  
Thorpe le Soken  
Clacton on Sea  
C16 0LE

**Project**  
Proposed Dwelling  
Land Adj. Ashcroft,  
St Michaels Road,  
Thorpe le Soken, Essex.

**Drawing**  
External Works / Landscaping

**Client**  
FGH (Essex) Ltd

**Scale**  
Print @ A1  
Date  
December 2021

**Job Number**  
HCS107  
Status  
PLANNING

**Drawing No. / Rev**  
ASH - 02