

General Notes:
 Do not scale dimensions from this drawing, unless for Planning purposes.
 The Contractor is responsible for checking all dimensions on site prior to commencement of the works.

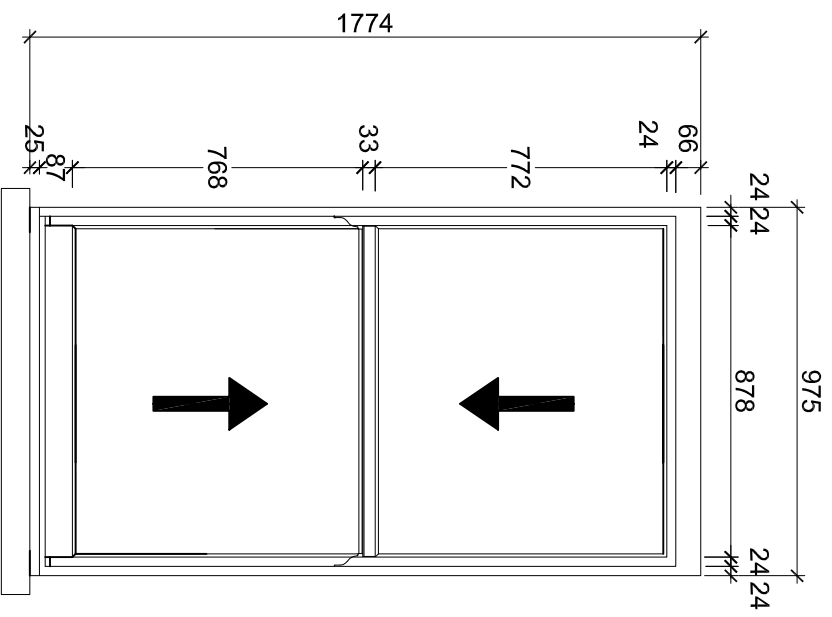

Dimensions as W1

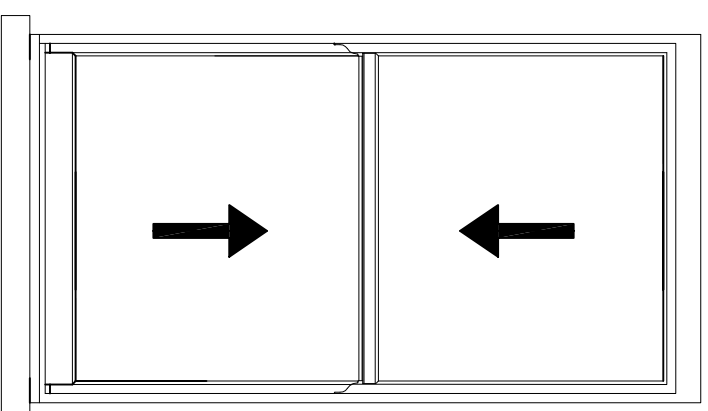

Dimensions as W1

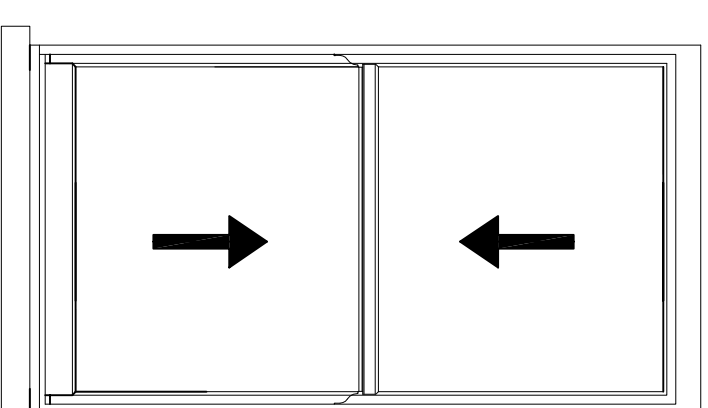

W1

W2

W3

Spacer set in place to block out new frames.

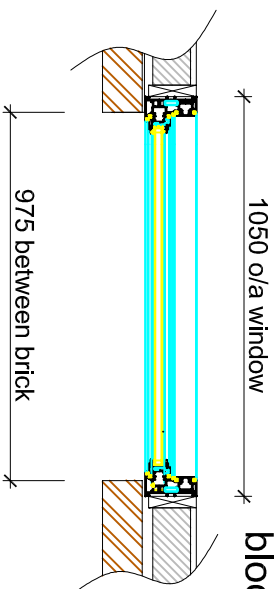

SPECIAL NOTE: Vertical sash windows set back behind brickwork.

Brian Elstone Surveying Services Ltd

Brian Elstone, MCIQB, IMapS, FCABE
 Building Surveyor and Architectural Consultant
 CDM Consultant
 1 Herne Court, Station Road, Rustington,
 West Sussex, BN16 3BQ
 Phone: 01903 784884, Mobile: 07710 593021.
 Email: brian@elstone.biz

Client:
 Fryzer Property Services, 30 York Road, Worthing, BN11 3EN

Project:
 Window Replacement - 67 St Leonards Ave. Hove, BN3 4QH

Drawing Title:
 Proposed Windows sheet 2

Revision	Date	Description
Scale:	Date:	Drawn By:
1:20	08/12/2021	BE
Drawing Number:	Revision:	
1495-005	-	