

General Notes:
 Do not scale dimensions from this drawing, unless for Planning purposes.
 The Contractor is responsible for checking all dimensions on site prior to commencement of the works.

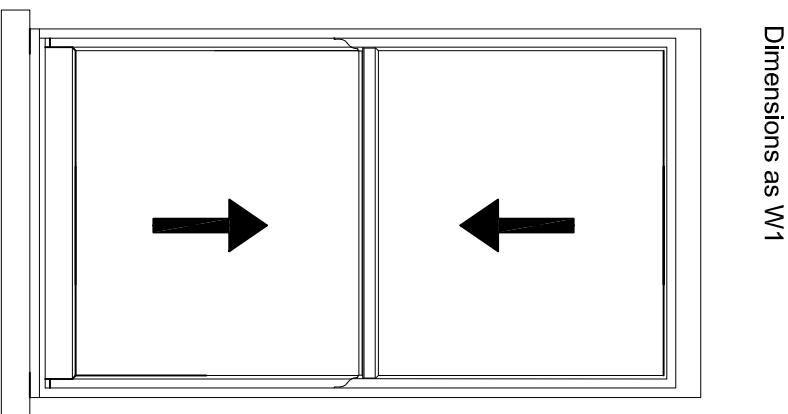
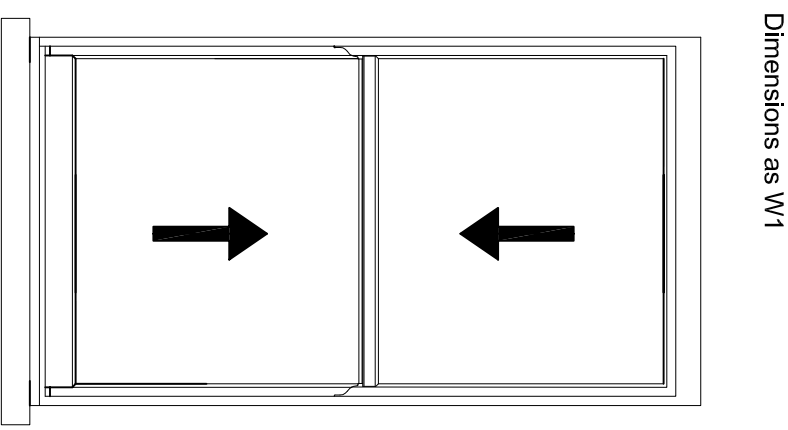
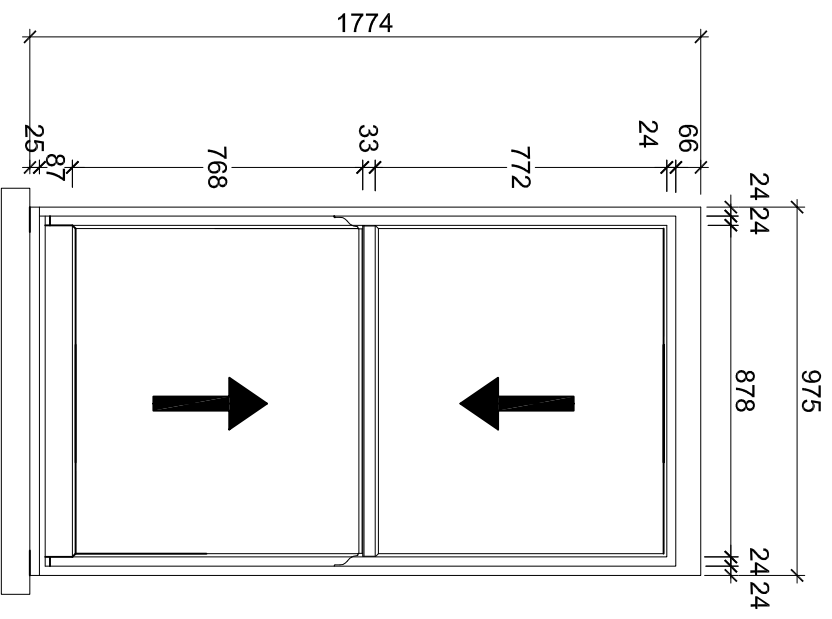

W1

W2

W3

Spacer set in place to block out new frames.

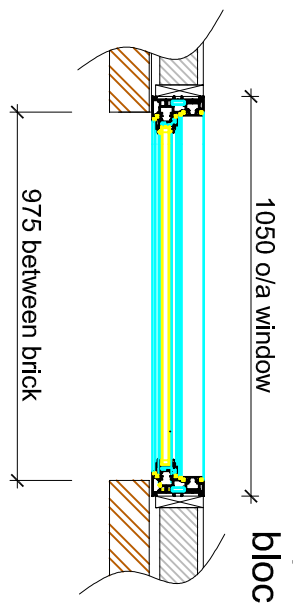

SPECIAL NOTE: Vertical sash windows set back behind brickwork.

Brian Elstone Surveying Services Ltd
 Brian Elstone, MCIQB, IMapS, FCABE
 Building Surveyor and Architectural Consultant
 CDM Consultant
 1 Herne Court, Station Road, Rusington,
 West Sussex, BN16 3BQ
 Phone: 01903 784884, Mobile: 07710 593021.
 Email: brian@elstone.biz

Client:	Fryzer Property Services, 30 York Road, Worthing, BN11 3EN
Project:	Window Replacement - 67 St Leonards Ave. Hove, BN3 4QH
Drawing Title:	Proposed Windows sheet 1

Revision	Date	Description
Scale:	Date:	Drawn By:
1:20	08/12/2021	BE
Drawing Number:	Revision:	
1495-004	-	