

HEAD

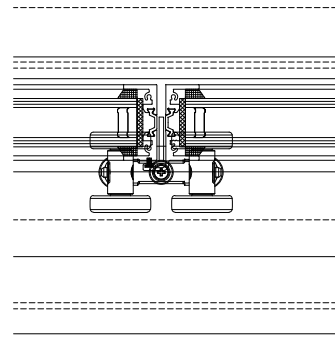

HINGE

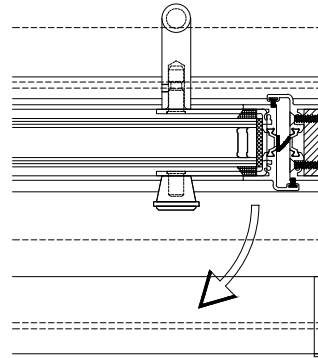

JAMB

DOUBLE GLAZED, POWDER COATED
THERMALLY BROKEN METAL BIFOLD DOORS

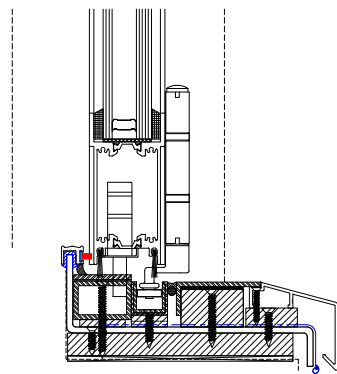

CILL

**NB - ALL EXTENSION
WINDOWS/DOORS TO BE IN DARK
ANTHRACITE METAL - OTHER
THAN TIMBER DOORS WHICH ARE
TO BE NATURAL ALONG WITH
CLADDING**

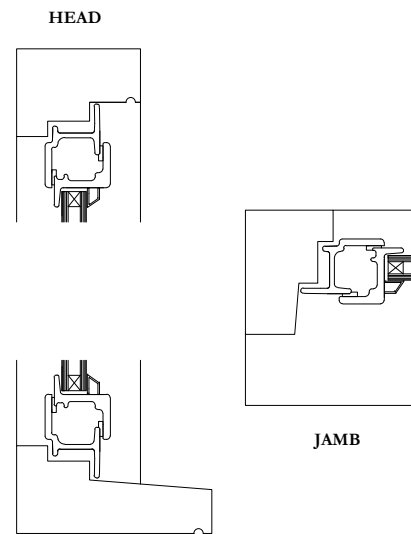

HEAD

JAMB

CILL

DOUBLE GLAZED, POWDER COATED
METAL CASEMENT WINDOWS - OPENING

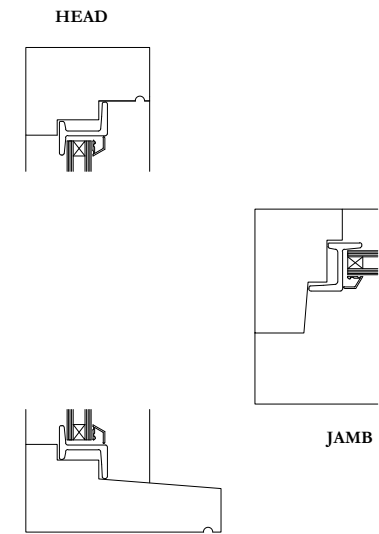

HEAD

JAMB

CILL

DOUBLE GLAZED, POWDER COATED
METAL CASEMENT WINDOWS - FIXED

NOTES

CONTRACTOR TO CHECK AND VERIFY ALL BUILDING AND SITE DIMENSIONS, LEVELS AND DRAINAGE LEVELS PRIOR TO COMMENCEMENT. THE CONTRACTOR IS EXPECTED TO COMPLY IN ALL RESPECTS WITH CURRENT BUILDING REGULATIONS, BUILDING LEGISLATION, BRITISH STANDARDS OF WORKMANSHIP, CDM 2015 REGULATIONS AND PARTY WALL ACTS, WHERE APPLICABLE - WHETHER OR NOT STATED ON THIS DRAWING.

THIS DRAWING MUST BE READ IN CONJUNCTION WITH ANY OTHER STRUCTURAL, GEOTECHNICAL OR SPECIALIST DOCUMENTATION PROVIDED.

THIS DRAWING IS NOT INTENDED TO SHOW DETAILS OF GROUND CONDITIONS OR CONTAMINANTS. AREAS OF GROUND TO BE RELIED UPON FOR SUPPORT BY STRUCTURE DEPICTED - INCLUDING DRAINAGE - IS TO BE INVESTIGATED BY THE CONTRACTOR. A SUITABLE METHOD OF FOUNDATION SHOULD BE PROVIDED ALLOWING FOR EXISTING GROUND CONDITIONS. ANY SUSPECT OR FLUID GROUND, CONTAMINATION OR WITHIN THE GROUND SHOULD BE FURTHER INVESTIGATED BY A SUITABLE EXPERT.

WHERE EXISTING TREES ARE TO BE RETAINED THEY SHOULD BE SUBJECT TO A FULL ARBORICULTURAL INSPECTION AND REPORT WHERE NECESSARY, FOR SAFETY AND COMPLIANCE PURPOSES. ANY NEW TREE PLANTING SHOULD BE A MINIMUM OF 5 METRES FROM BUILDINGS AND 3 METRES FROM DRAINAGE OR SERVICES UNLESS SPECIFIED/AGREED OTHERWISE. A SUITABLE METHOD OF FOUNDATION IS TO BE DESIGNED IF CLOSE TREE PLANTING IS PROPOSED - AT THE CONTRACTORS RESPONSIBILITY.

SEAN D PEMBLE RIBA AND SEAN PEMBLE ARCHITECTS DO NOT ACCEPT ANY RESPONSIBILITY FOR LOSSES - FINANCIAL OR OTHERWISE - TO ANY CLIENT OR THIRD PARTY ARISING OUT OF THE CLIENTS (BE IT DEVELOPER OR CONTRACTOR BUT NOT LIMITED THERETO) NON COMPLIANCE WITH AFOREMENTIONED PROVISOS.

THIS DRAWING IS THE PROPERTY OF SEAN D PEMBLE RIBA AND SEAN PEMBLE ARCHITECTS AND MAY NOT BE COPIED OR USED FOR ANY PURPOSE OTHER THAN THAT FOR WHICH IT IS SUPPLIED WITHOUT THE EXPRESS WRITTEN AUTHORITY OF SEAN D PEMBLE RIBA OR SEAN PEMBLE ARCHITECTS.

FOR DISCHARGE

DWG No: SK4

REVISION:

SCALE: 1:5 @ A3

TITLE:

**DETAILS AS PROPOSED
JAN. MMXXII**

CLIENT/PROJECT:

**SWISS COTTAGE, BROGYNTYN
FOR BROCKTON HOUSE FARM/J ROSS DEVELOPMENTS**

Sean Pemble
Architects



SEAN D PEMBLE RIBA
23 BRYNHAFOD ROAD
OSWESTRY SHROPSHIRE
SY11 1RT

TEL: +447740 486697
EMAIL: INFO@SEANPEMBLEARCHITECTS.CO.UK