

Proposed First Floor Plan

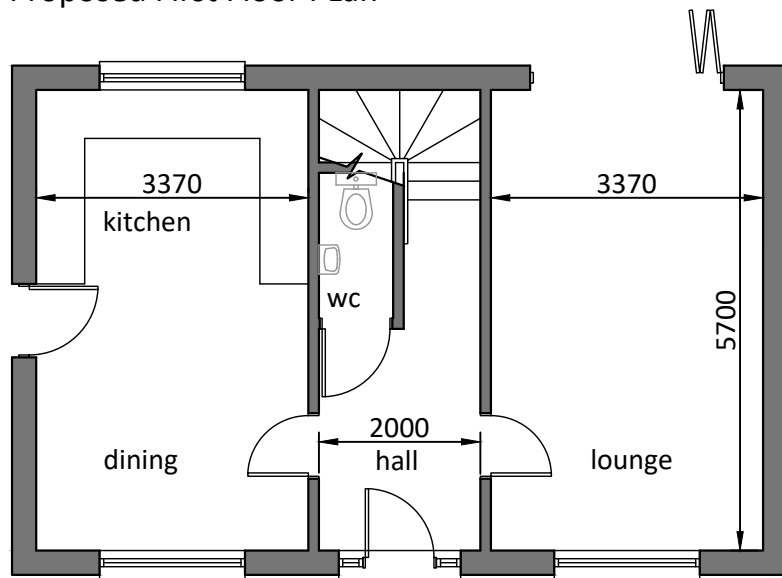

Proposed Ground Floor Plan

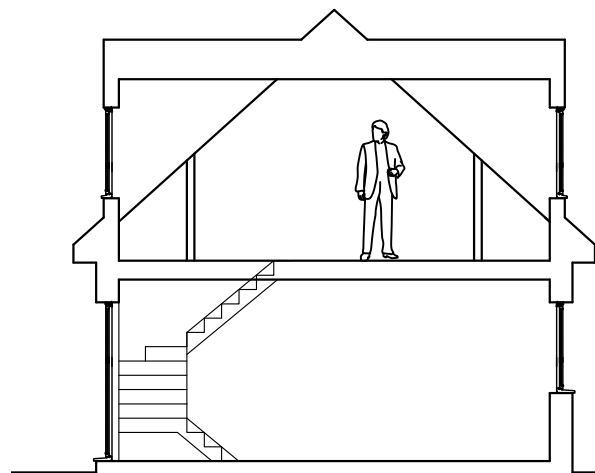

Section through lounge

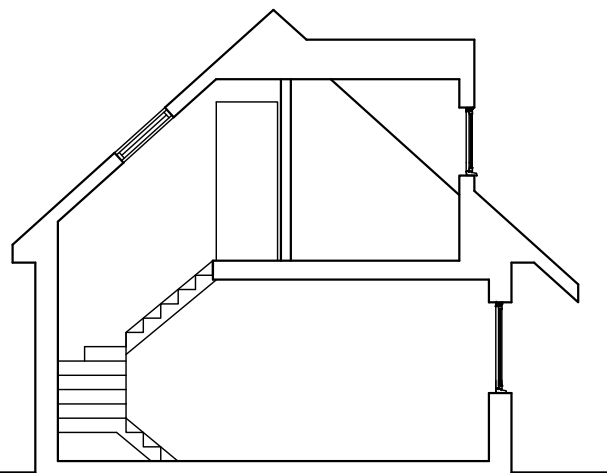

Section through hall



Proposed Front Elevation

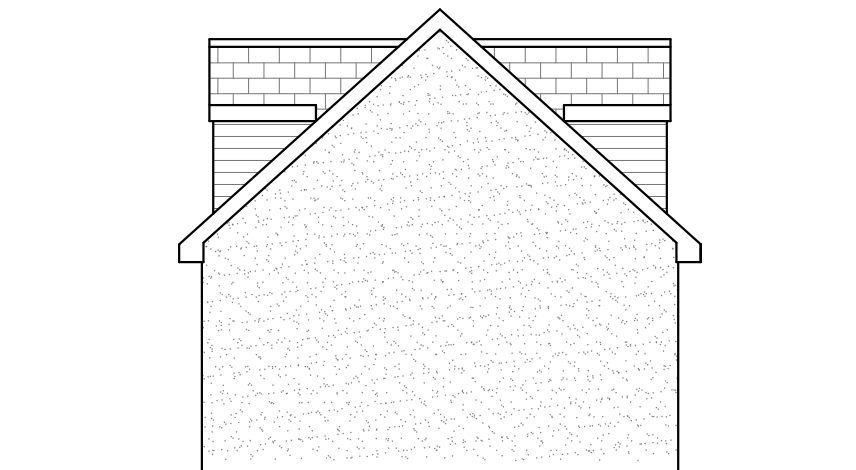

Proposed Side Elevation

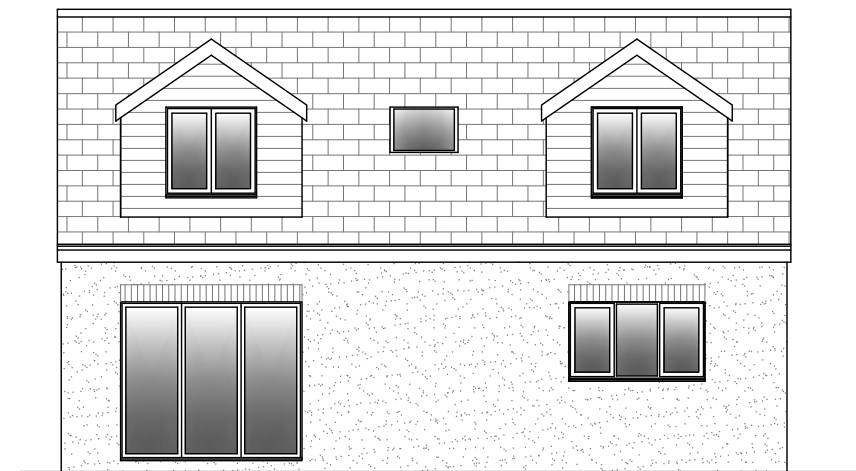

Proposed Rear Elevation

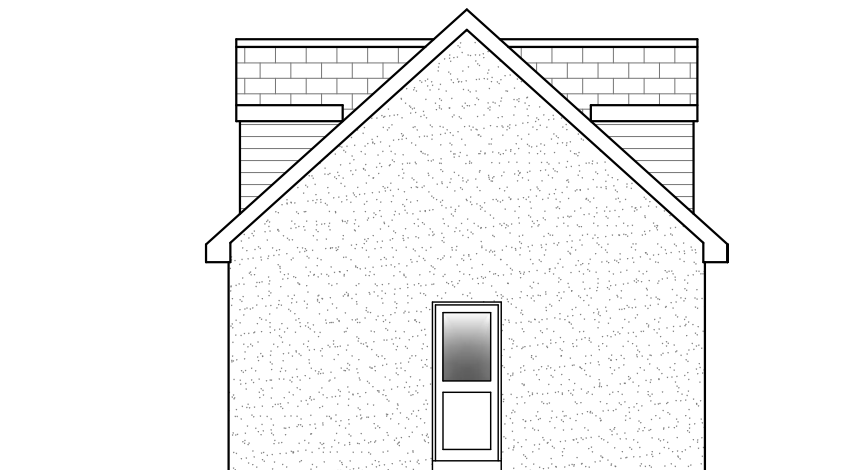

Proposed Side Elevation

Amendments

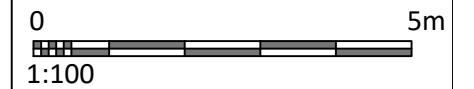

**N GITTINS  
Architecture**

28 Brean Down Avenue  
Weston-super-Mare, BS23 4JQ  
Tel: 01934 424555 email: mail@nigel-gittins.co.uk

Client:  
**Jo Ashley**

Project:  
**New Dwelling  
Fimra  
Hutton Moor Lane  
Weston-super-Mare**

Drawing:  
**Proposed Plans and  
Elevations**

Scale:  
**1:100**

Drawn By:

Drawing No.:  
**2354/ p /3/ 02**