

DISCLAIMER NOTE
 ADJACENT PROPERTIES AND BOUNDARIES ARE SHOWN FOR ILLUSTRATIVE PURPOSES ONLY AND HAVE NOT BEEN SURVEYED UNLESS OTHERWISE STATED.
 ALL AREAS SHOWN ARE APPROXIMATE AND SHOULD BE VERIFIED BEFORE FORMING THE BASIS OF A DECISION. DO NOT SCALE OTHER THAN FOR PLANNING APPLICATION PURPOSES. ALL DIMENSIONS MUST BE CHECKED BY THE CONTRACTOR BEFORE COMMENCING WORK ON SITE.
 THE COPYRIGHT OF THIS DRAWING REMAINS WITH **SJM PLANNING** AND MAY NOT BE REPRODUCED IN ANY FORM WITHOUT WRITTEN CONSENT.

North

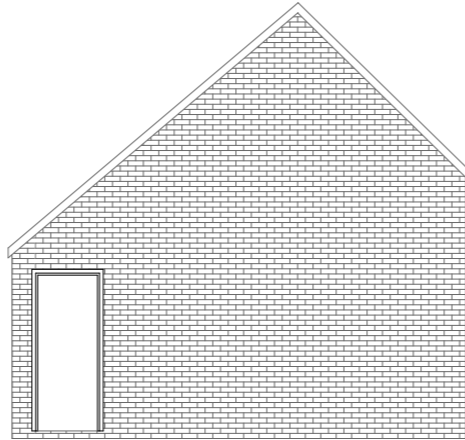

West

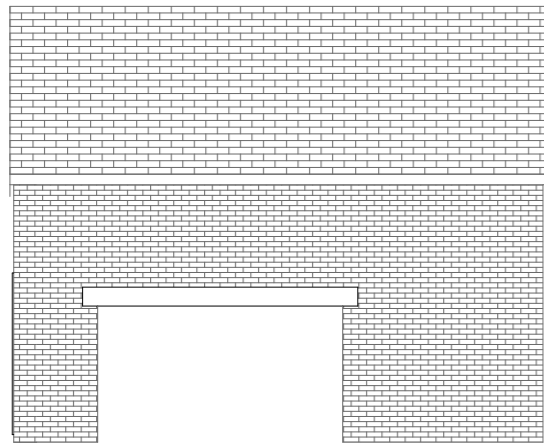

East

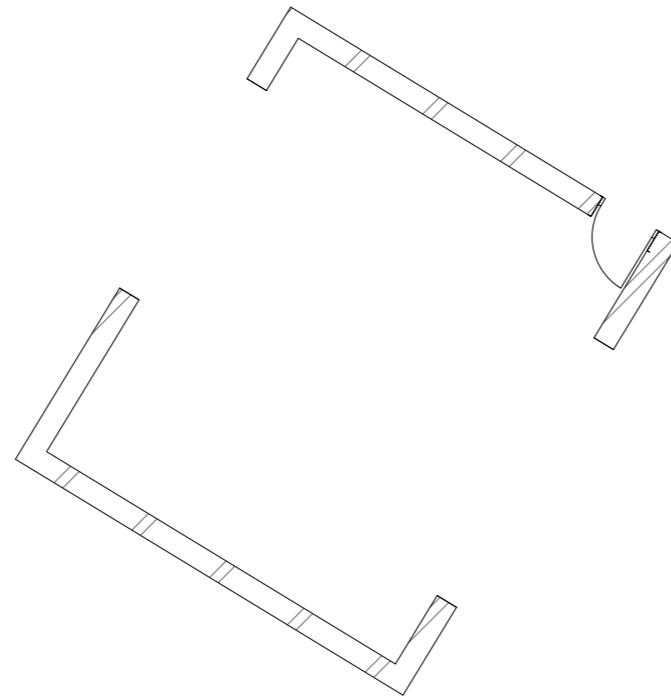
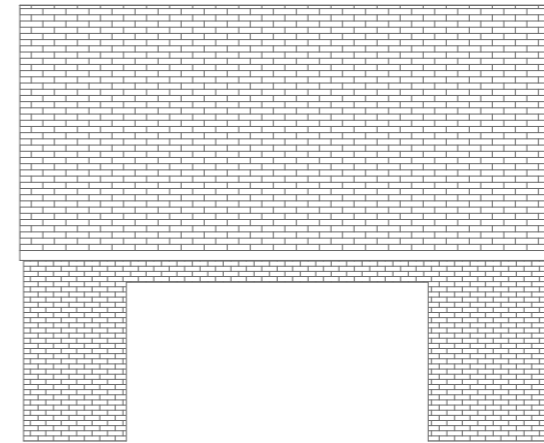

South

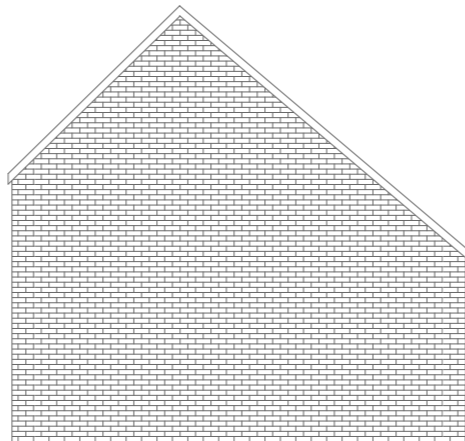

N

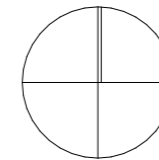

Rev	Date	Detail

Status **PLANNING DRAWINGS**

SJM PLANNING
 The Old Granary, Stettill Farm, Snoll Hatch Road,
 East Peckham, Tonbridge, Kent, TN12 5EE
 T. 01892 882288 E. enquiries@sjmplanning.com
 www.sjmplanning.com

Client **Mr Webb**

Site Address
**Hop Pole Inn
 Maidstone Road
 Nettlestead Green
 Maidstone
 Kent, ME18 5HH**

Drawing Title
Existing Floor Plans and Elevations

Scale **1:100 @ A3** Date **31 January 2022** Drawn **GB**

Drawing N° **2022-1044v1-Exist** Rev

THE COPYRIGHT IN THIS DOCUMENT AND DESIGN IS CONFIDENTIAL TO AND THE PROPERTY OF SJM PLANNING.