

evolution[®]

Technical Manual
2018



Index

SECTION 01 - CROSS SECTIONAL WINDOW DRAWINGS

Page 01.01	STORM 2 - 56mm Outer Frame
Page 01.02	STORM 2 - 72mm Outer Frame
Page 01.03	STORM 2 - Concealed head ventilation
Page 01.04	STORM 2 - Dummy Transom
Page 01.05	STORM 2 - Flying Mullion
Page 01.06	FLUSH - 56mm Outer Frame
Page 01.07	FLUSH - 72mm Outer Frame
Page 01.08	FLUSH - Concealed head ventilation
Page 01.09	FLUSH - Flying Mullion
Page 01.10	15mm Frame Extender

SECTION 02 - BAY WINDOWS

Page 02.01	Variable Bay Pole Assembly
Page 02.02	Variable Bay Pole Cover trim Combinations
Page 02.03	Variable Bay Pole Deductions
Page 02.04	Variable Bay Pole Load Bearing Capability
Page 02.05	Square Bay Pole Assembly
Page 02.06	Square Bay Pole Load Bearing Capability
Page 02.07	Bay Reference Dimensions
Page 02.08	STORM 2 / FLUSH Bow Coupler Trims

SECTION 03 - CROSS SECTIONAL DOOR DRAWINGS

Page 03.01	Open in STORM 2 Door with 44mm Threshold
Page 03.02	STORM 2 Door Threshold Options
Page 03.03	STORM 2 Door 70mm Mullion
Page 03.04	STORM 2 Door 116mm Midrail / Mullion
Page 03.05	STORM 2 Door 190mm Midrail
Page 03.06	STORM 2 French Door Overlap
Page 03.07	Open in DOOR With Part M Threshold on 160mm x 45mm Cill
Page 03.08	STORM 2 Open in Door Swing & Clearance
Page 03.09	Door & Side Panel Coupling
Page 03.10	Standard Door Hinge Positioning
Page 03.11	Door Spyhole heights



Index

SECTION 04 - MANUFACTURING AND SIZE LIMITATIONS

Page 04.01	STORM Maximum Casement Sash Sizes
Page 04.02	FLUSH Maximum Casement Sash Sizes
Page 04.03	STORM Minimum Sizes to achieve Part B Fire Escape
Page 04.04	FLUSH Minimum Sizes to achieve Part B Fire Escape
Page 04.05	STORM Minimum Sizes for 12" Egress Easy Clean Hinges
Page 04.06	FLUSH Minimum Widths for 12" Egress Easy Clean Hinges
Page 04.07	Minimum Manufacturing Sizes for Timberlook Sash Joints
Page 04.08	Single Door Maximum /Minimum Dimensions
Page 04.09	French Door Maximum/Minimum Dimensions
Page 04.10	Cottage Door Maximum/Minimum Dimensions
Page 04.11	Circular Windows and Bends
Page 04.12	Minimum Side Panels Widths with Letterplates
Page 04.13	Minimum size to achieve Part B Fire Escape With a Top Hung Casement Sash
Page 04.14	Frame Coupling
Page 04.15	STORM 2 Frames on 30mm Cills
Page 04.16	STORM 2 Frames on 30mm Cills - 2
Page 04.17	JOINING STORM 2 Cills

SECTION 05 - GEORGIAN BARS

Page 05.01	GEORGIAN BAR Combinations
Page 05.02	GEORGIAN BAR Measuring

SECTION 06 - PROFILE SECTIONS

Page 06.01	OUTER Frame Profiles
Page 06.02	Transom/Mullion Profiles
Page 06.03	Casement Sash Profiles
Page 06.04	Door Threshold Profiles
Page 06.05	Door Sash Profiles
Page 06.06	Door Midrail Profiles
Page 06.07	Cills Profiles
Page 06.08	Coupling Sections
Page 06.09	Glazing Bead & Georgian Bar Profiles

Bead and Glass here in your window

Sash

Outer Frame

Bead

Section A

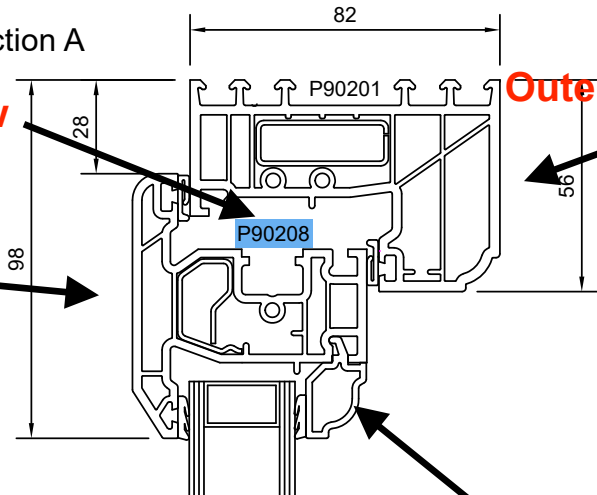

Section B

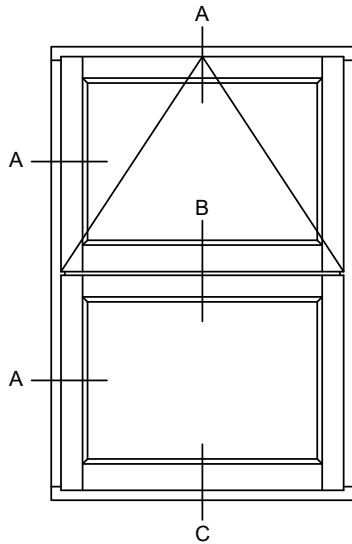
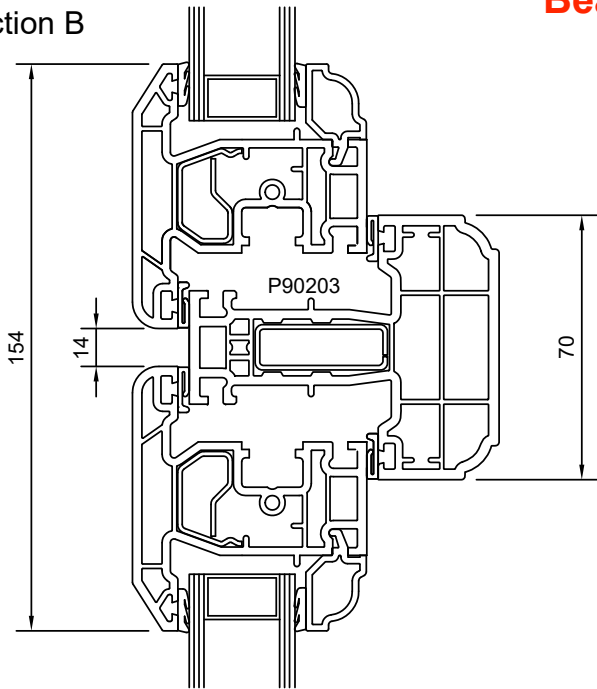

Section C

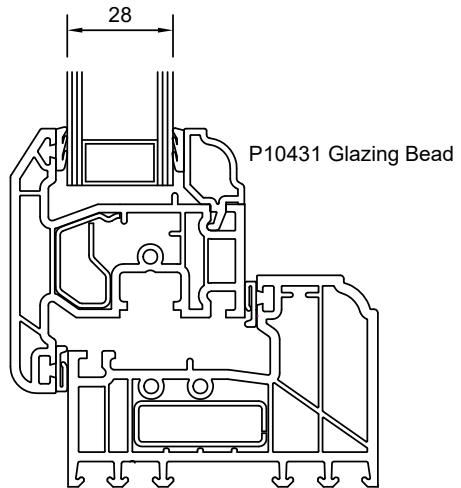
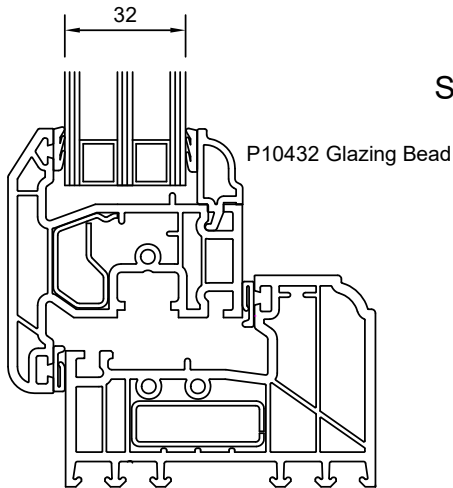

P91034 Head Drip / Ventilator Cover

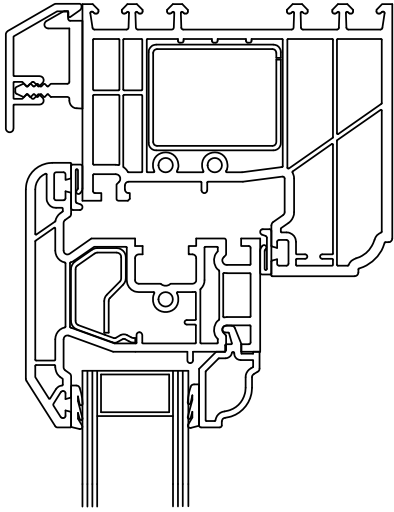

Section A

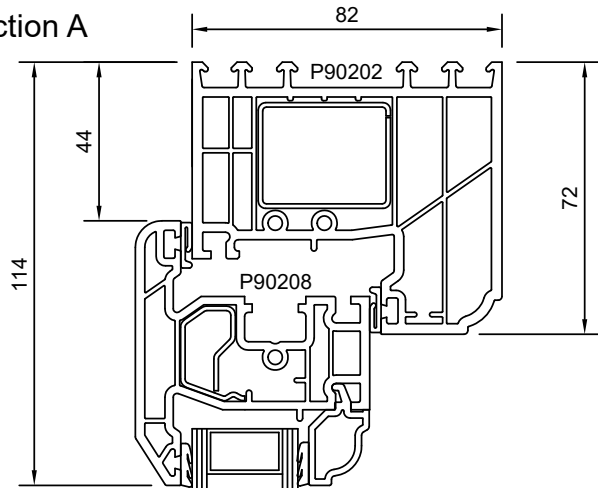

Section B

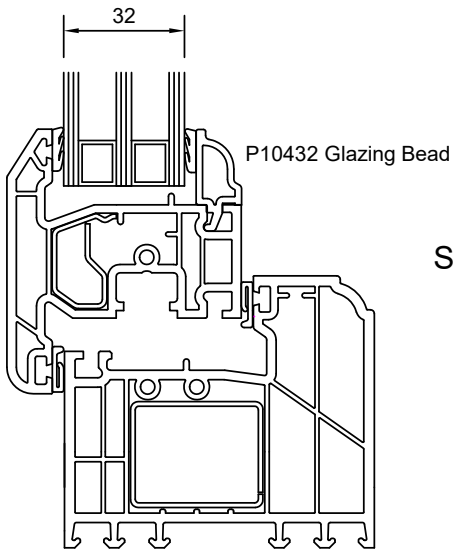
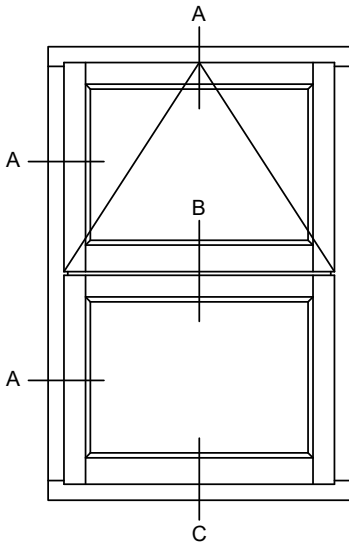
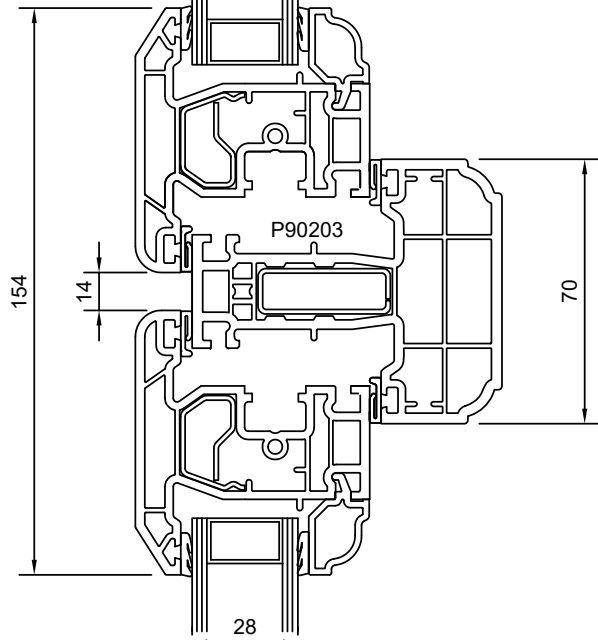

Section C

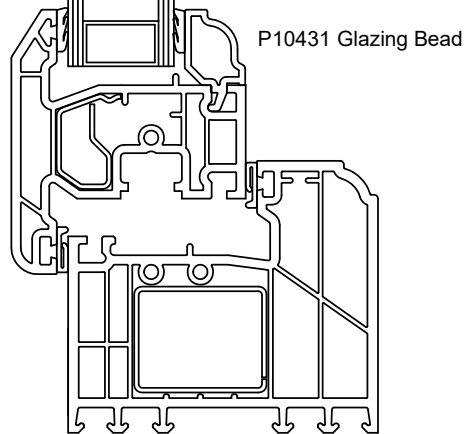

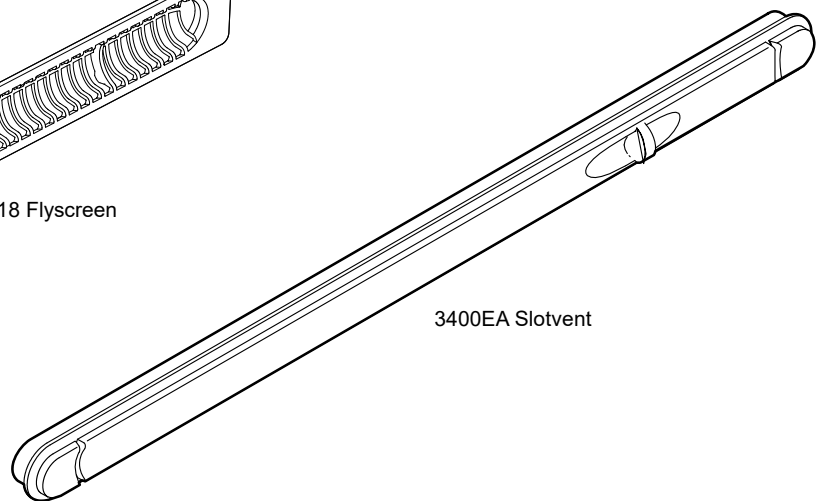
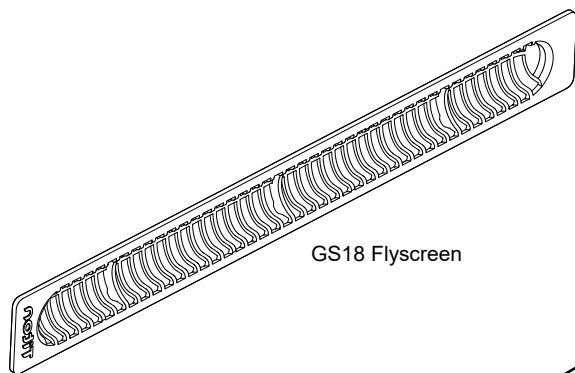
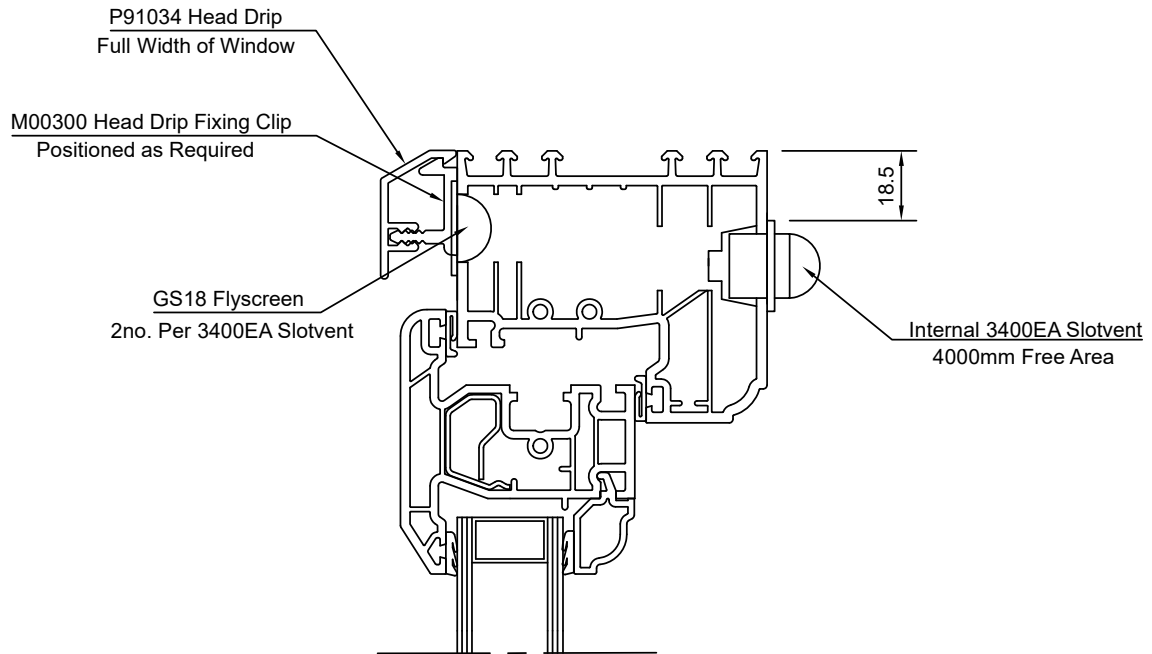

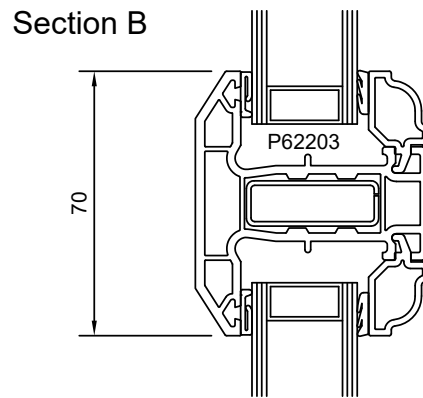
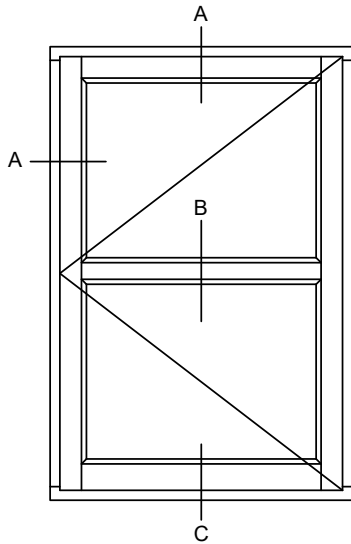
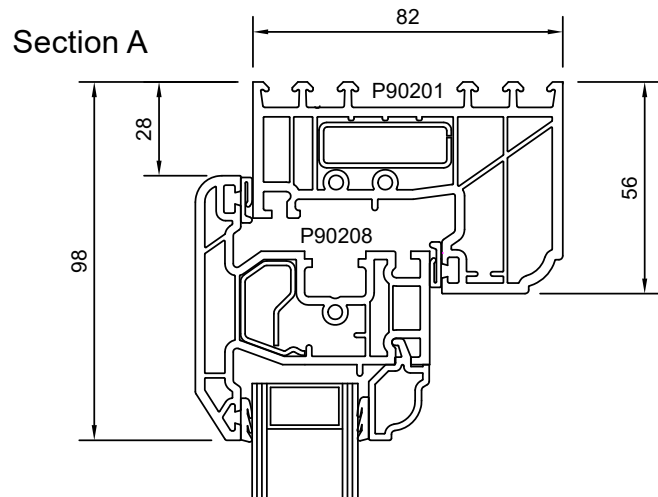

*Not available with Flush Casements

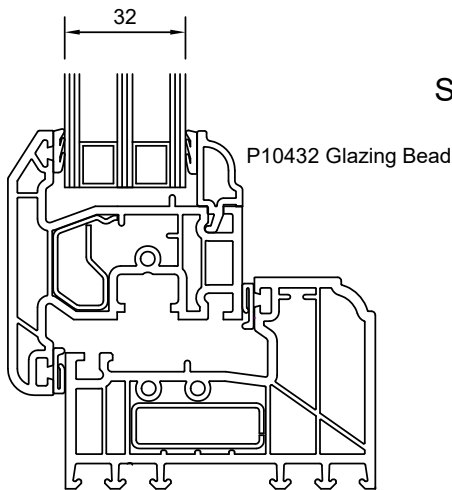

Section C

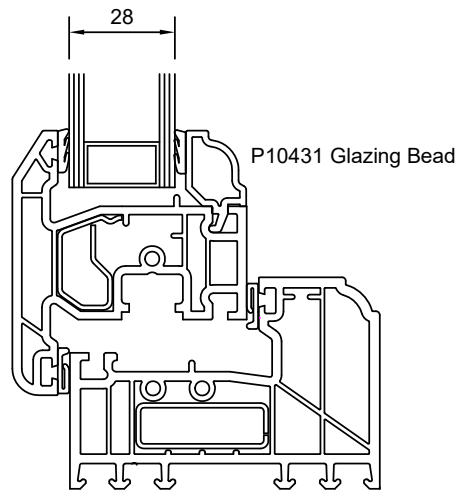

Section A

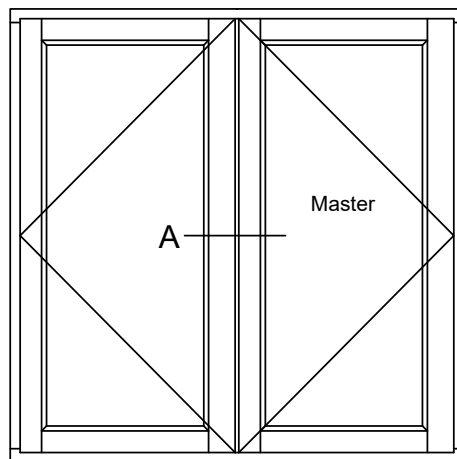
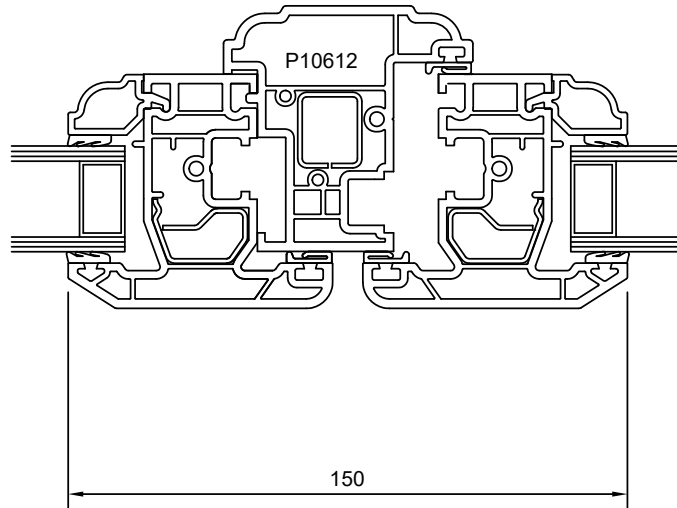

Section A

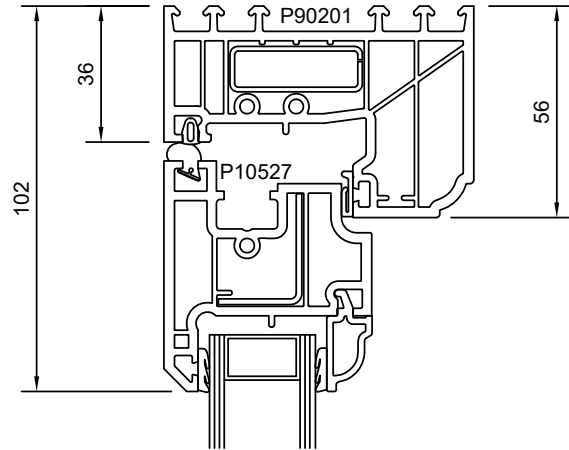

Section B

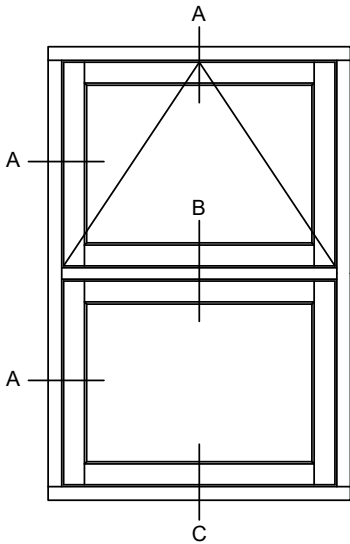
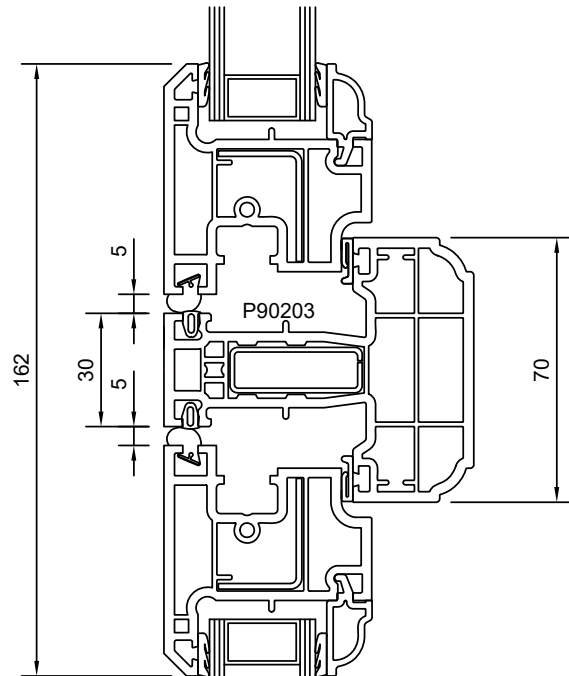

Section C

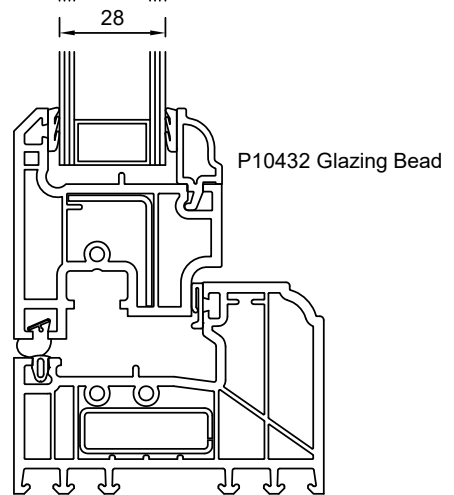
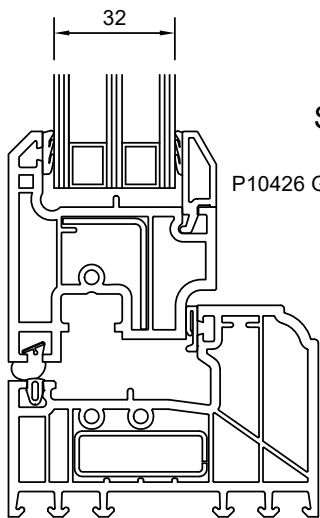

P91034 Head Drip / Ventilator Cover

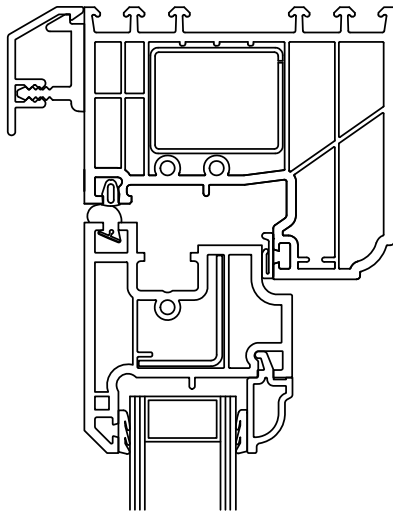

Section A

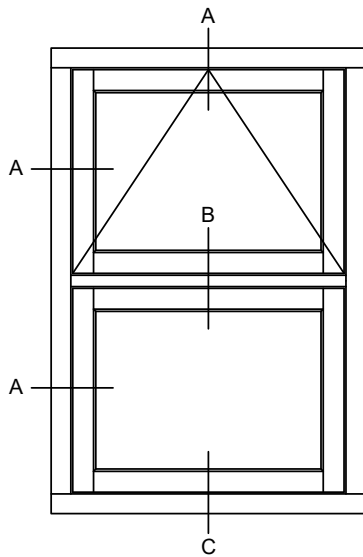
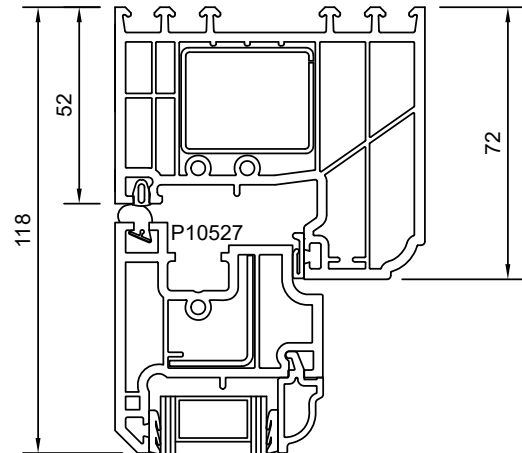

Section B

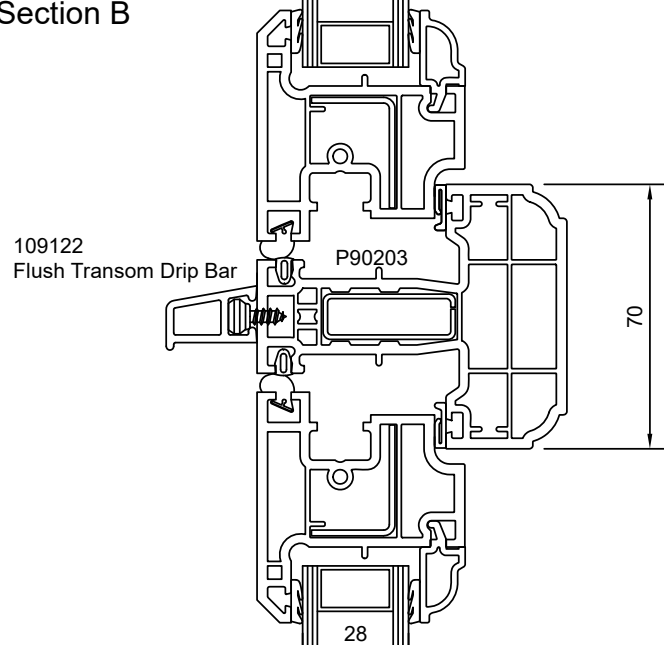

Section C

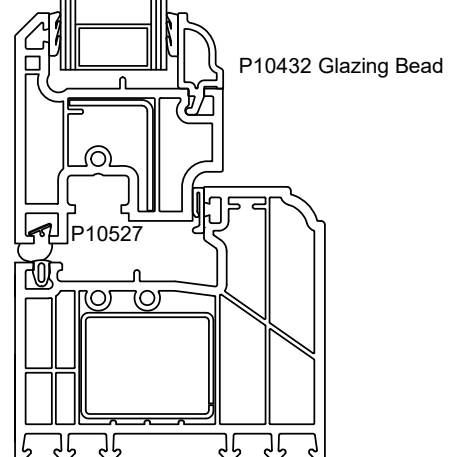
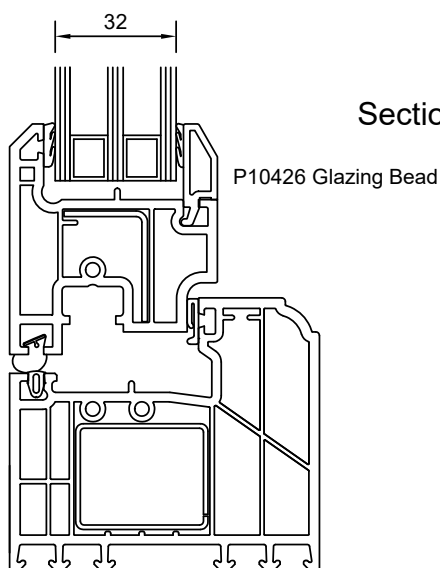

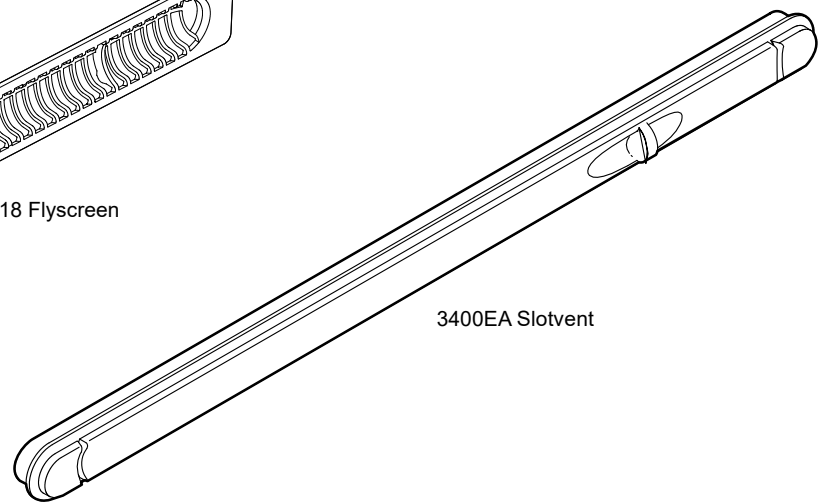
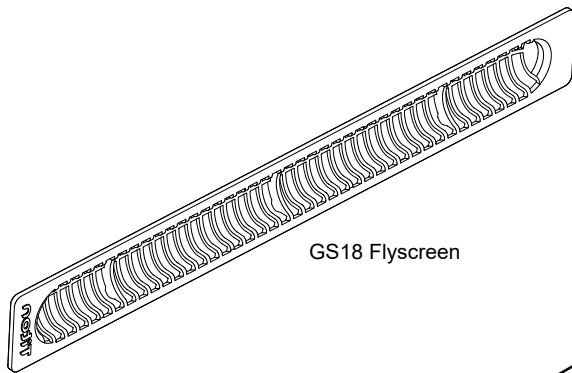
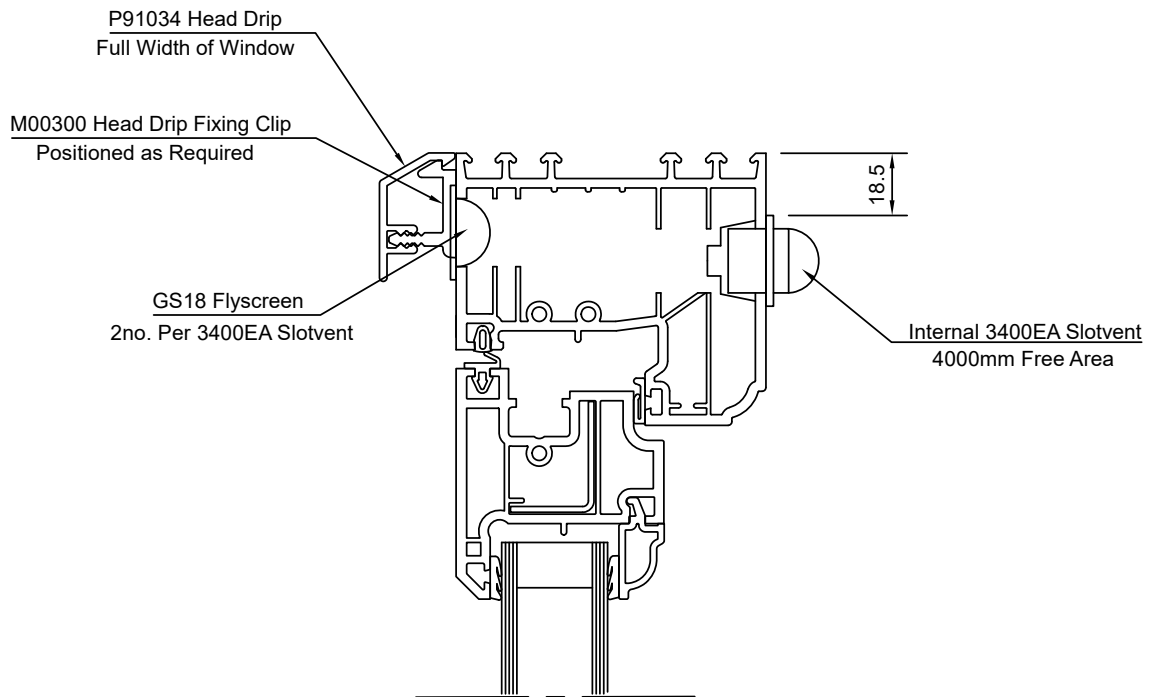

Section A

P10533

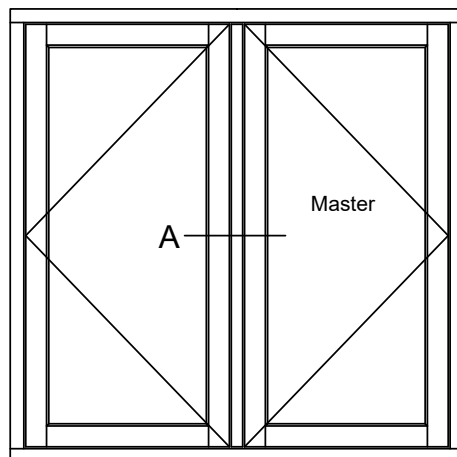
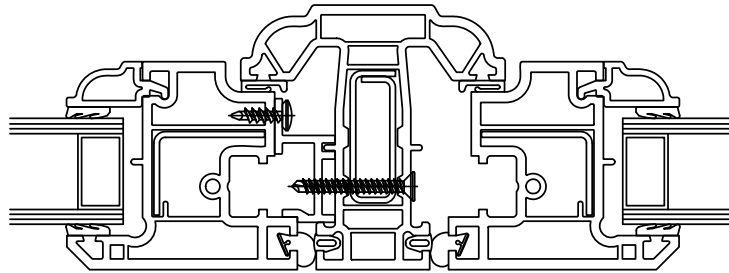

114 040 15mm Frame Extender

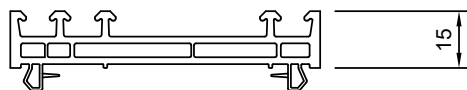

Clips to Head, Sides or Bottom of any Storm 2 Window or Door Outer Frame

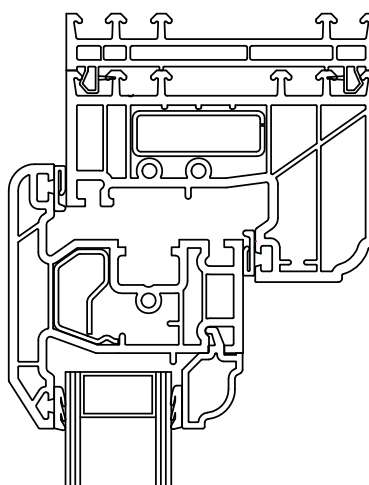

Please Note
If used in conjunction with Head Drip Bar,
the Extender will sit above the top of the
Outer Frame

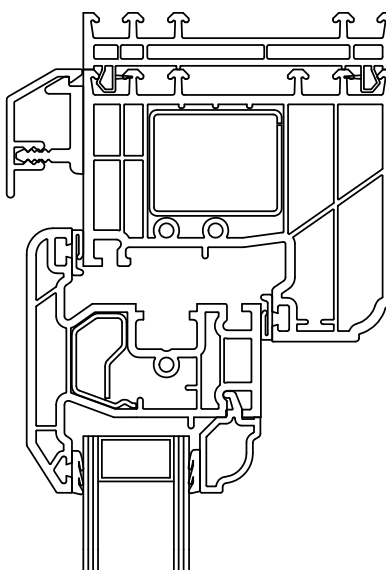

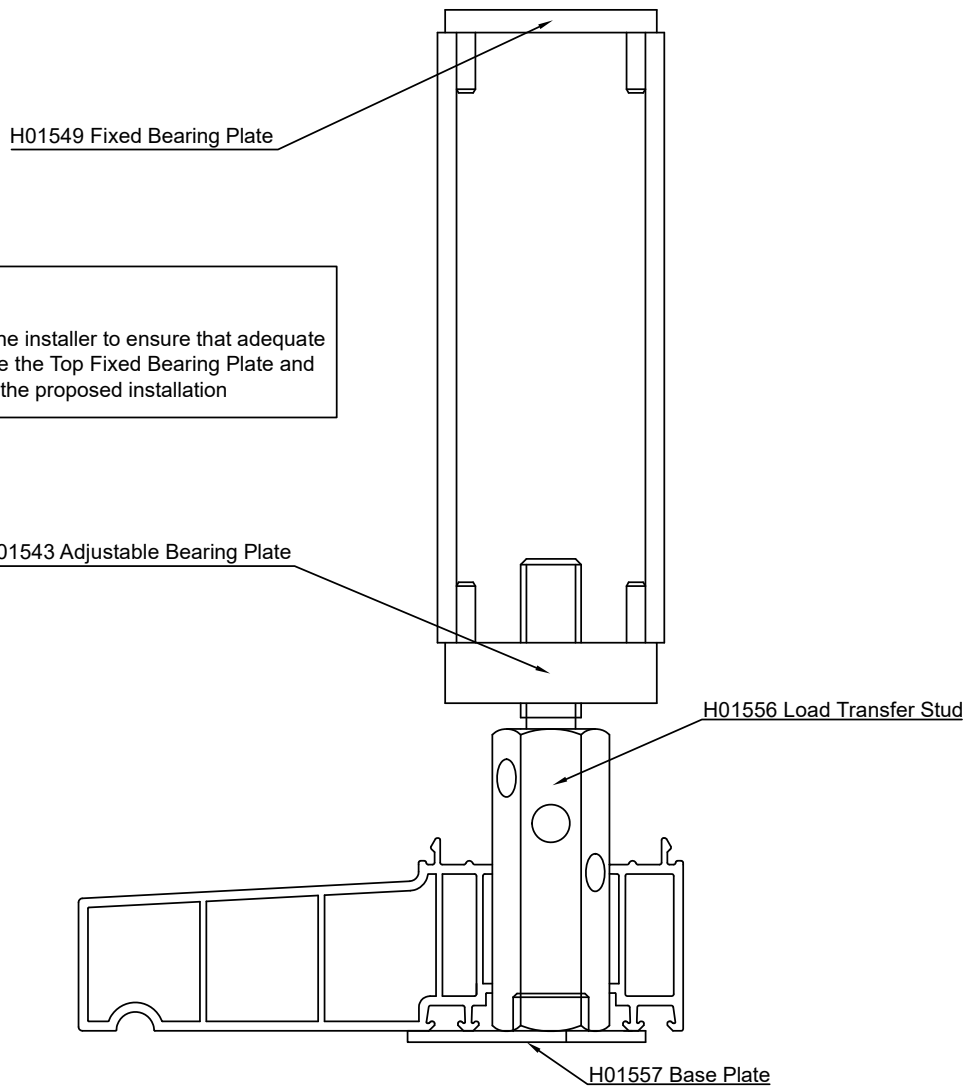
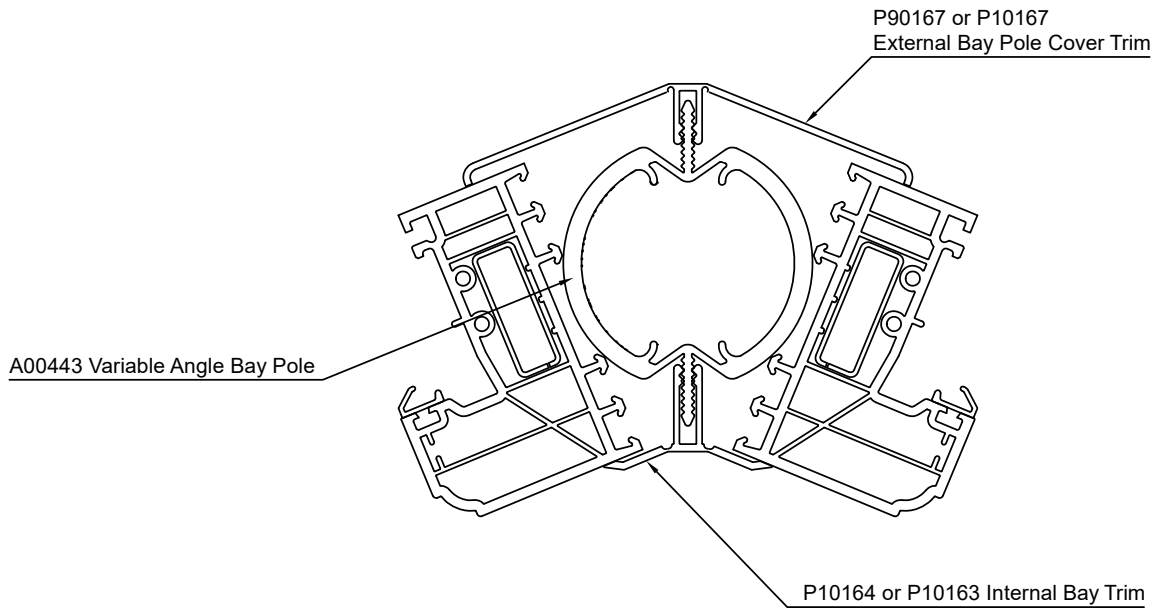

IMPORTANT

It is the responsibility of the installer to ensure that adequate support is provided above the Top Fixed Bearing Plate and below the Base Plate for the proposed installation

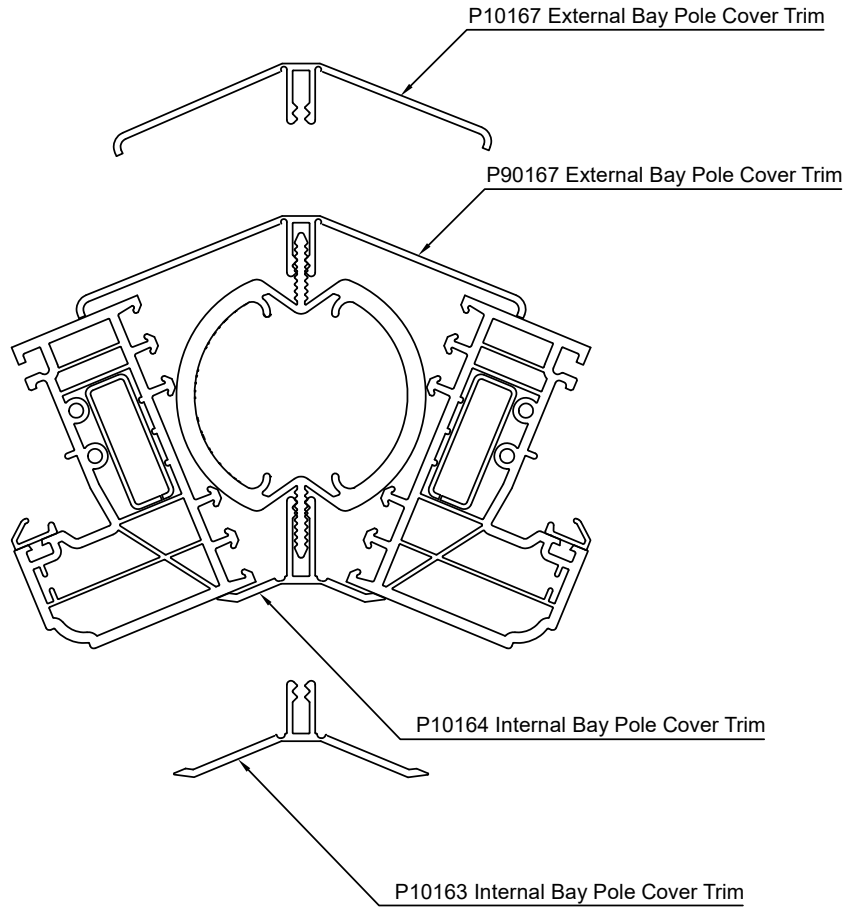

Bay Angle	External Bay Pole Cover	Internal Bay Pole Cover
110° - 119°	P90167	No Internal Cover
120° - 149°	P90167	P10164
150° - 155°	P90167	P10163
156° - 169°	P10167	P10163

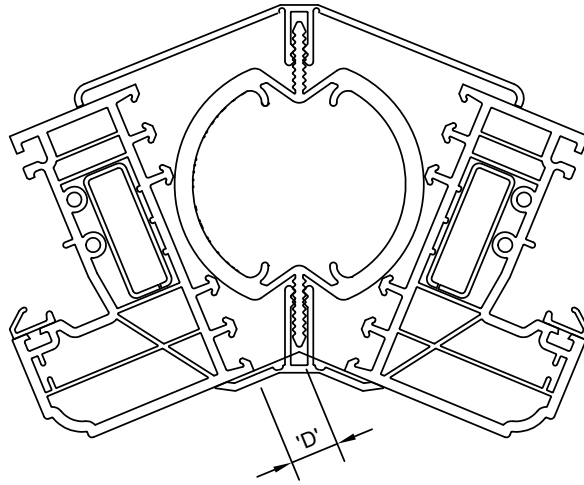

Bay Angle	Deduction 'D' mm
110°	0.9
111°	1.4
112°	1.9
113°	2.5
114°	3.0
115°	3.5
116°	4.0
117°	4.5
118°	5.0
119°	5.4
120°	5.9
121°	6.4
122°	6.9
123°	7.3
124°	7.8
125°	8.3
126°	8.7
127°	9.2
128°	9.6
129°	10.0
130°	10.5
131°	11.0
132°	11.3
133°	11.8
134°	12.2
135°	12.6
136°	13.0
137°	13.4
138°	13.9
139°	14.3

Bay Angle	Deduction 'D' mm
140°	14.7
141°	15.1
142°	15.5
143°	15.9
144°	16.3
145°	16.7
146°	17.1
147°	17.5
148°	17.8
149°	18.2
150°	18.6
151°	19.0
152°	19.4
153°	19.8
154°	20.1
155°	20.5
156°	20.9
157°	21.3
158°	21.6
159°	22.0
160°	22.4
161°	22.7
162°	23.1
163°	23.5
164°	23.8
165°	24.2
166°	24.6
167°	24.9
168°	25.3
169°	25.6

A00443

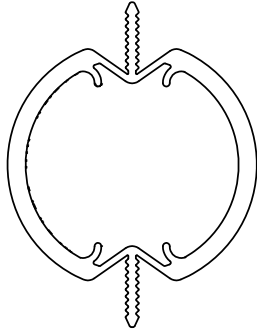

Height	Tonnes
500	7.73
600	7.44
700	7.24
800	7.05
900	6.75
1000	6.46
1100	6.26
1200	6.07
1300	5.77
1400	5.58
1500	5.5
1600	5.38
1700	5.09
1800	4.6
1900	4.11
2000	3.72
2100	3.33
2200	2.98
2300	2.84
2400	2.55
2500	2.35

Please note that the use of our adjustable bay jacking kits limits the load bearing capacity to 3 tonnes

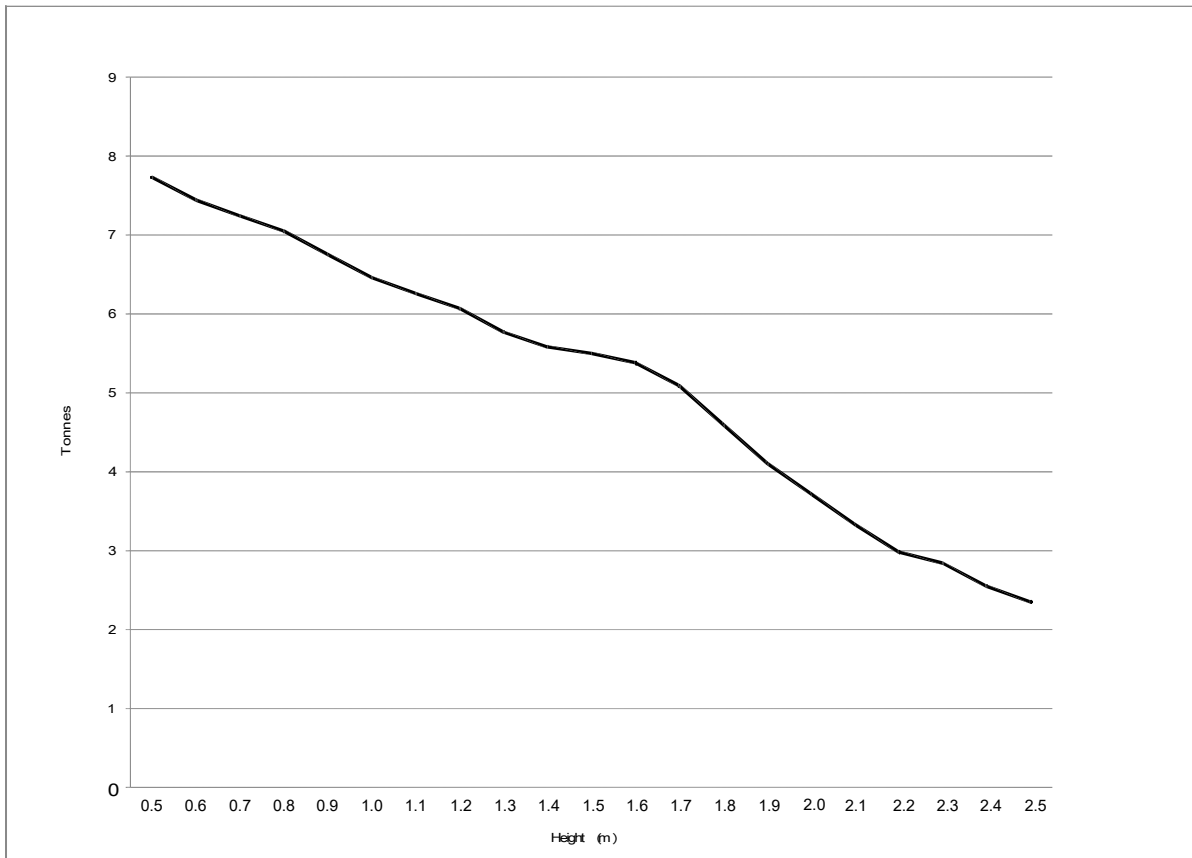

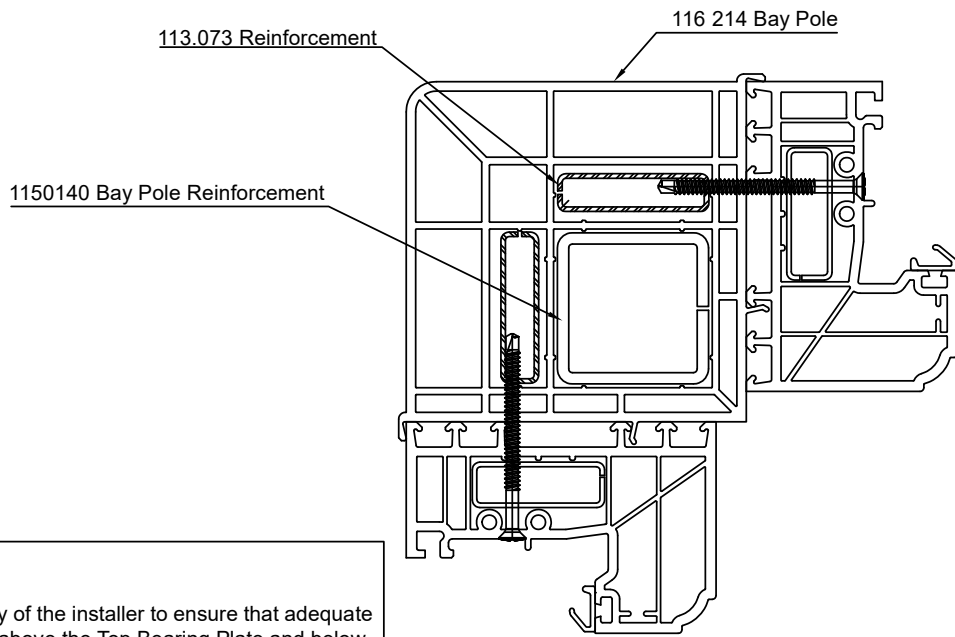

IMPORTANT

It is the responsibility of the installer to ensure that adequate support is provided above the Top Bearing Plate and below the Base Plate for the proposed installation

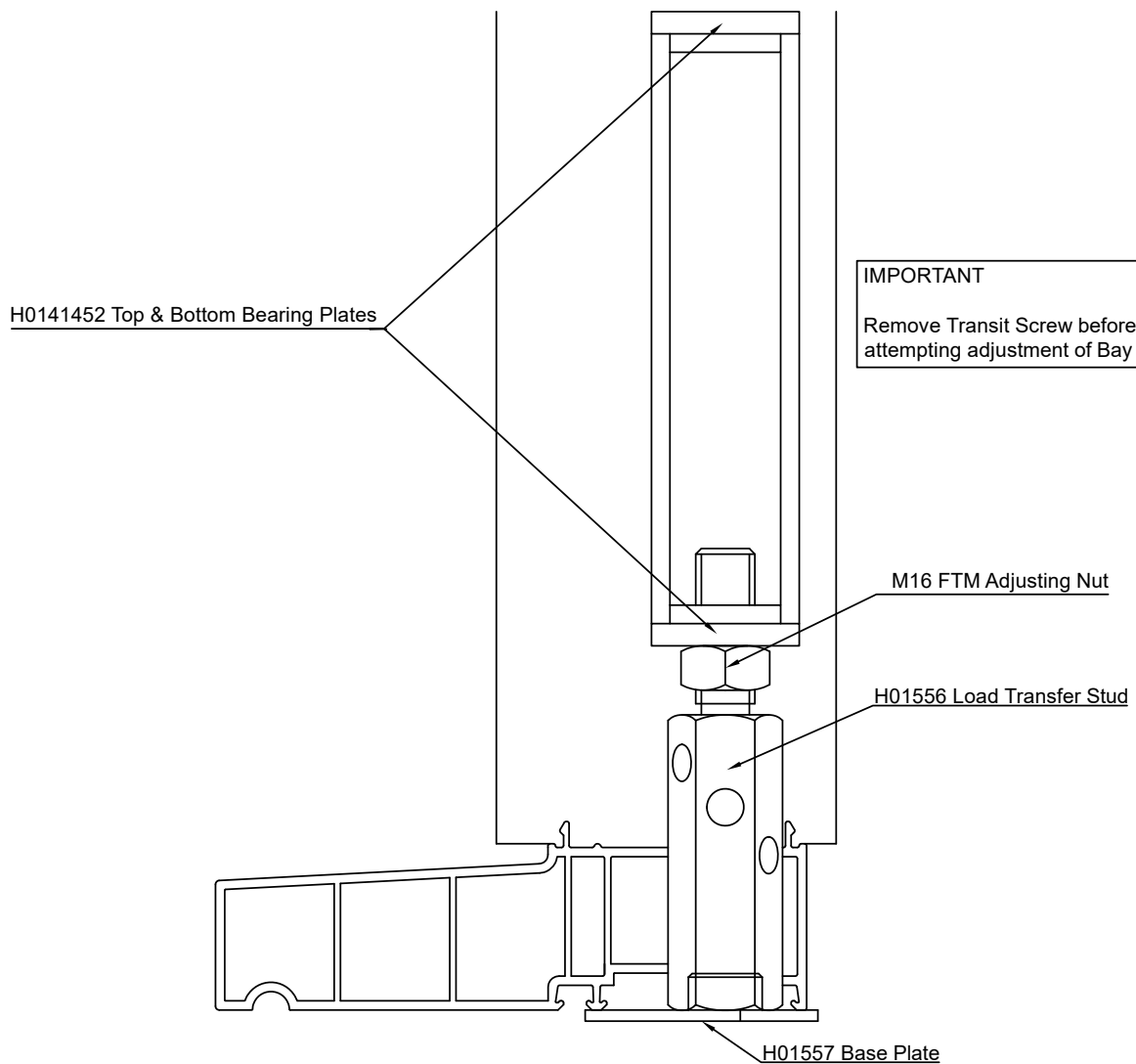

IMPORTANT

Remove Transit Screw before attempting adjustment of Bay Pole

113128

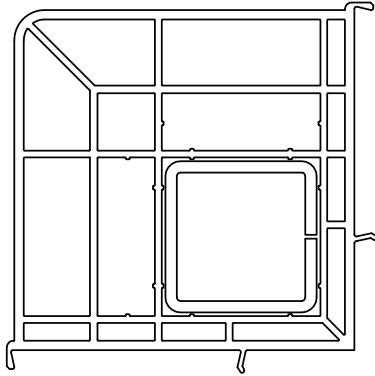

Height	Tonnes
500	3.82
600	3.76
700	3.64
800	3.56
900	3.41
1000	3.28
1100	3.05
1200	2.82
1300	2.51
1400	2.3
1500	2.14
1600	1.94
1700	1.74
1800	1.62
1900	1.47
2000	1.37
2100	1.25
2200	1.12
2300	1.01
2400	0.97
2500	0.87

Please note that the use of our adjustable bay jacking kits limits the load bearing capacity to 3 tonnes

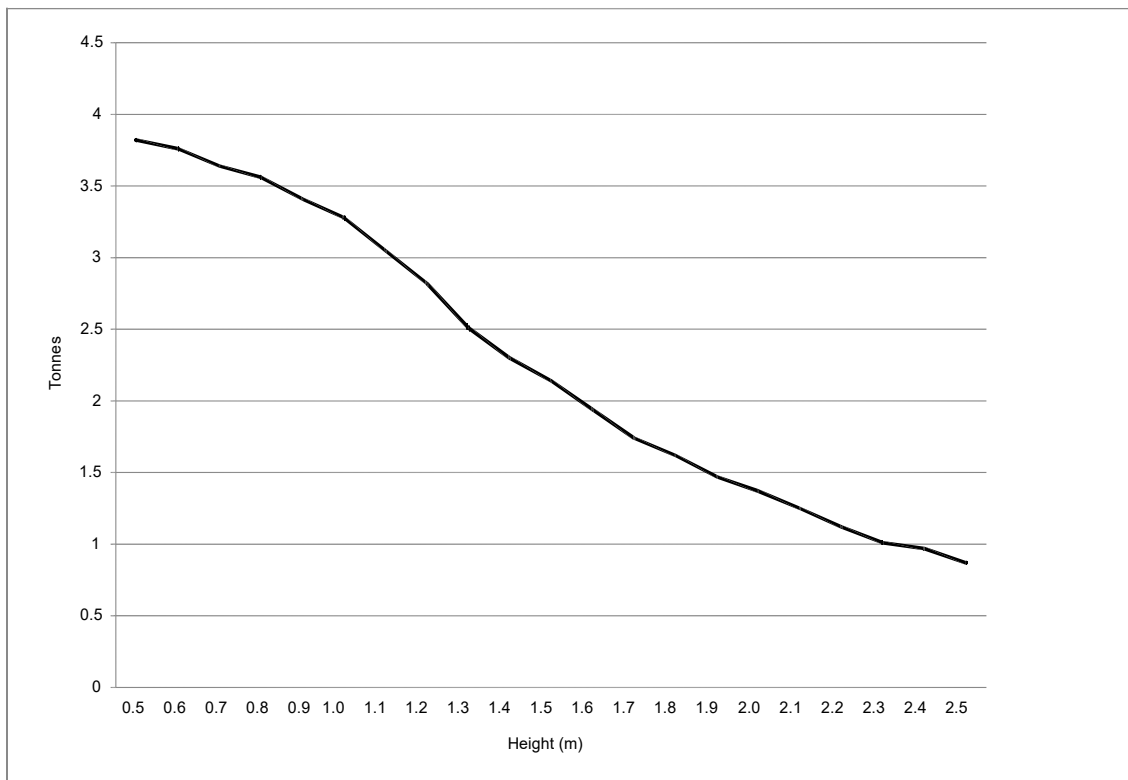

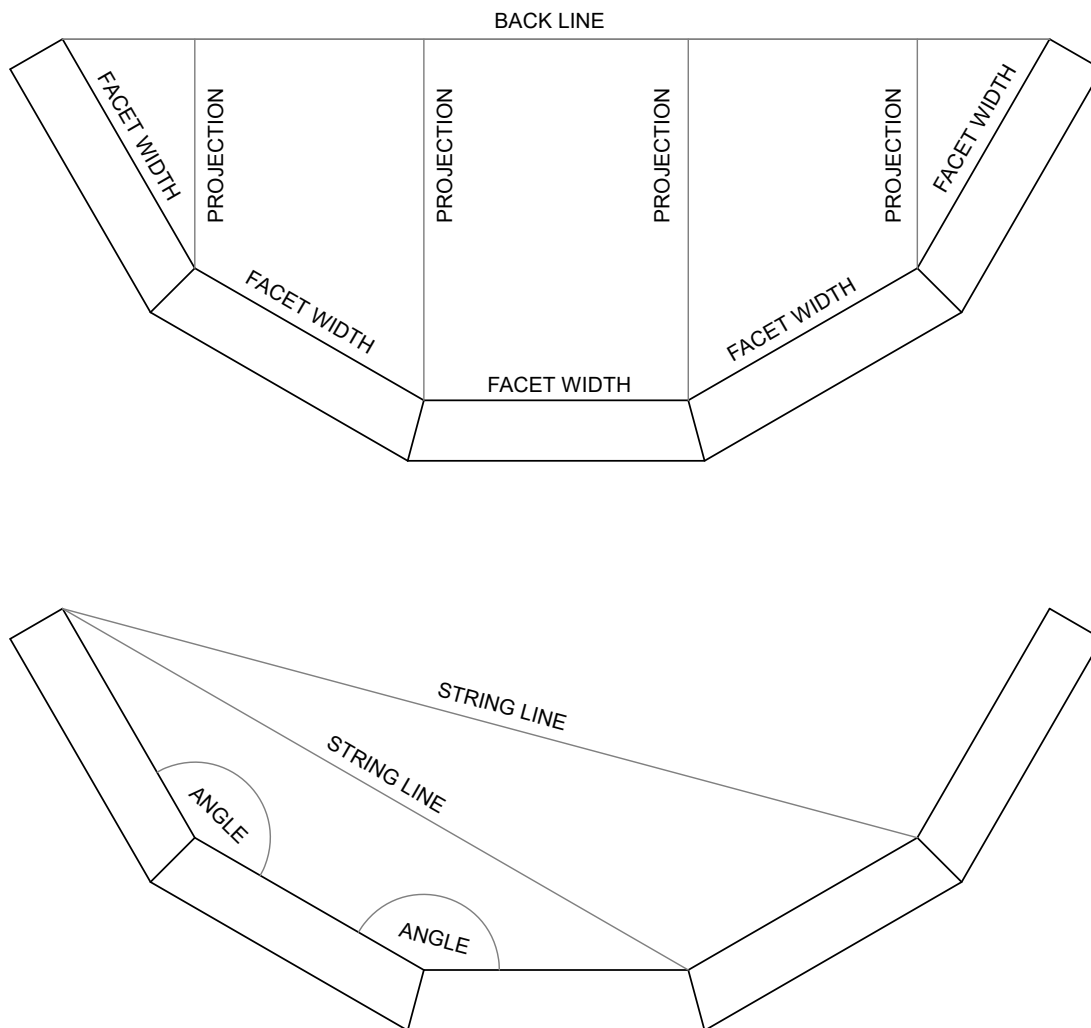

A Back Line measurement in combination with a Projection measurement only will result in a layout with equal Facet Widths and Angles, and works best for Bow Windows which are to be fitted into an opening where a flat window has been installed previously. We can input Bow Windows using the existing opening width of the window and our software will, at the press of a button, automatically reduce the dimensions so that the completed assembly fits neatly into the existing opening.

For the most part, if measuring an existing Bay Window internally, the Facet Widths and internal Angles are sufficient to generate a layout. However, the addition of a Back Line measurement helps in checking the accuracy of the dimensions obtained.

Projections are not so easy to obtain as this requires the setting up of some form of datum piece from which to measure the Projections from.

String Lines can also be useful but, with the emergence of accurate angle measuring tools, this type of check measurement has become largely redundant.

Note.

All Evolution Bay Windows should be measured internally to allow them to fit back to existing window boards. If existing Bay Window frames have to be measured externally it is crucial that we know the thickness of the existing frames. Our software will only recognise 82mm and 70mm thick framework when calculating the internal measurements from external measurements.

Bay Pole Trims required when processing Storm 2 and Flush Bow or Bay Windows without Variable Bay Poles

Part No.
P10164

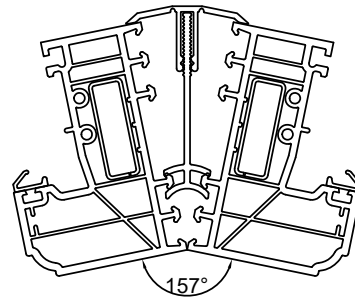
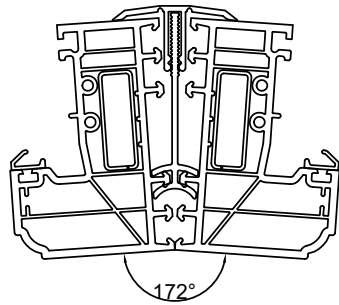

Part No.
P10163

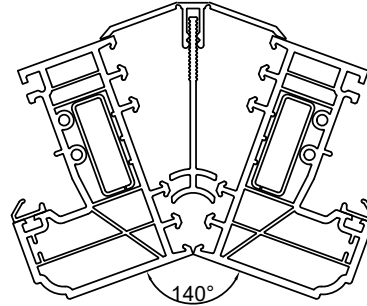
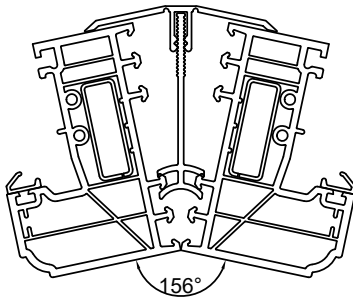

Most likely instances of Bow Windows being required without Variable Bay Poles are shown above

Part No.
P10167

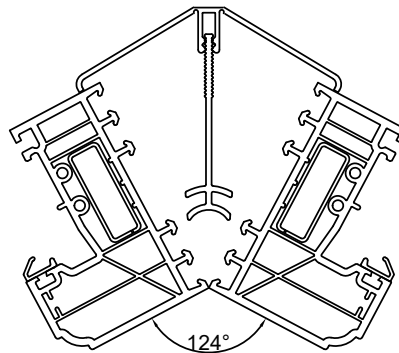
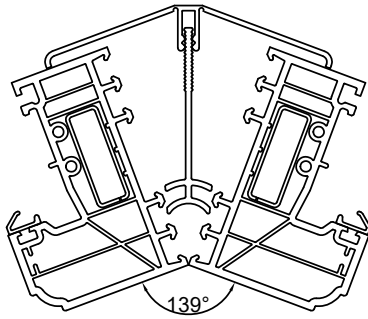

Part No.
P90167

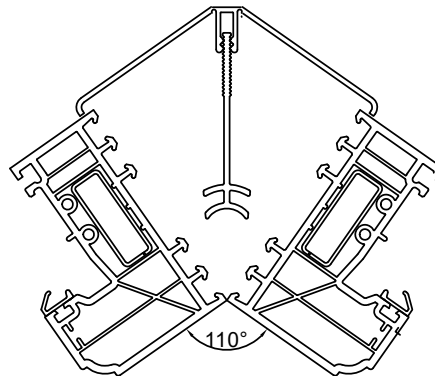
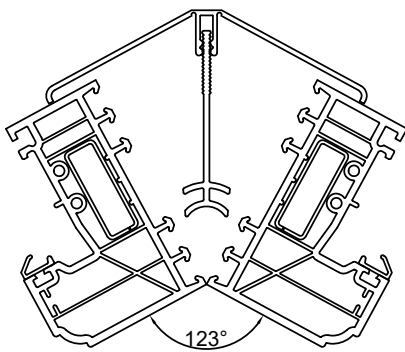

Slim Bow Coupler will probably be of no practical use with Bays that have angles narrower than 139°

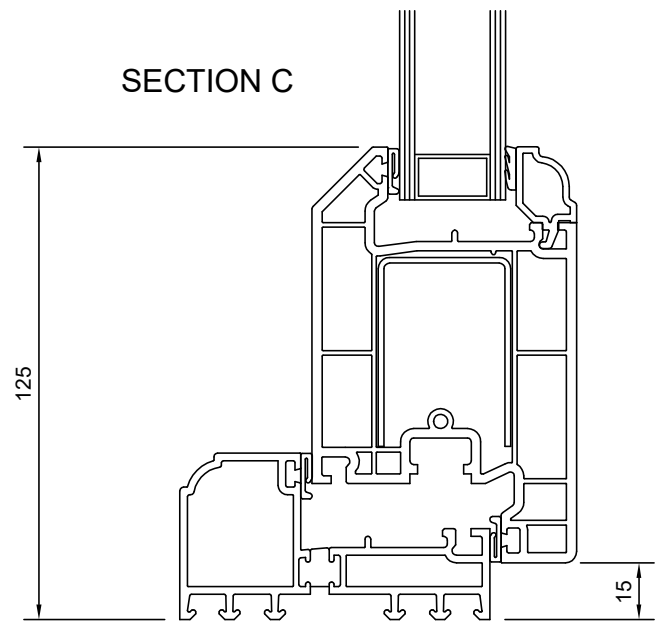
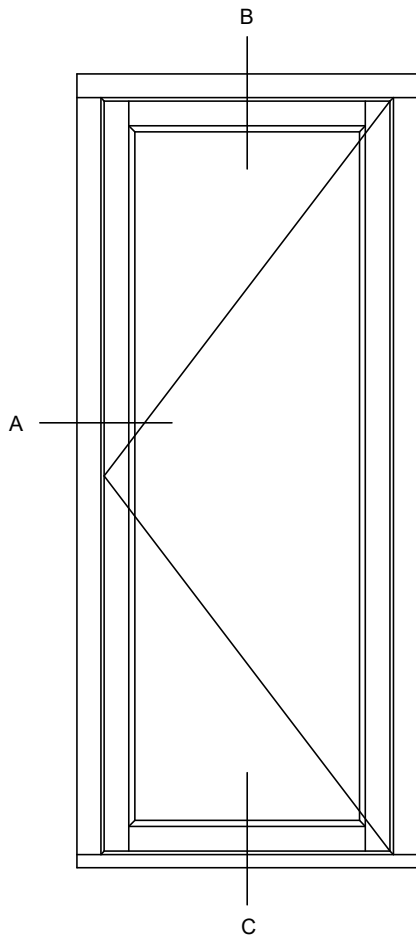
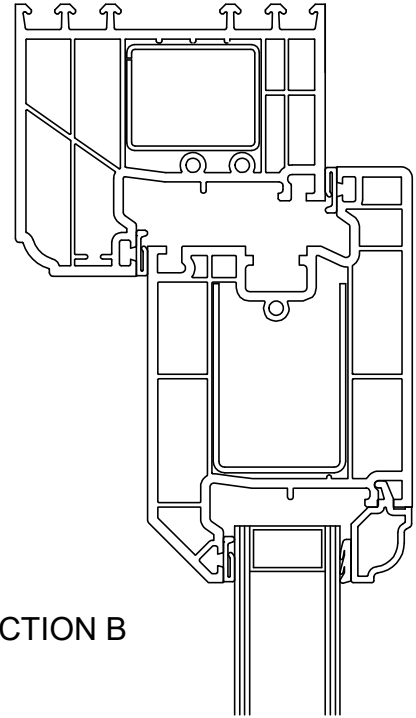
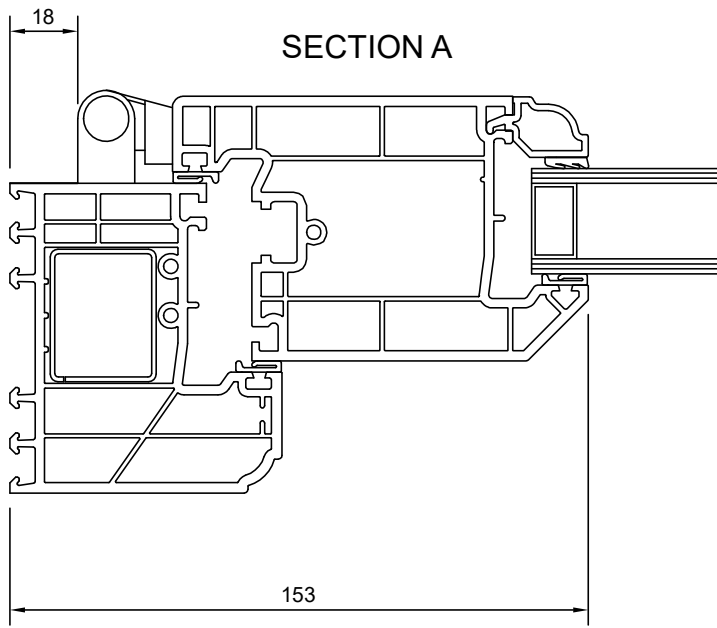

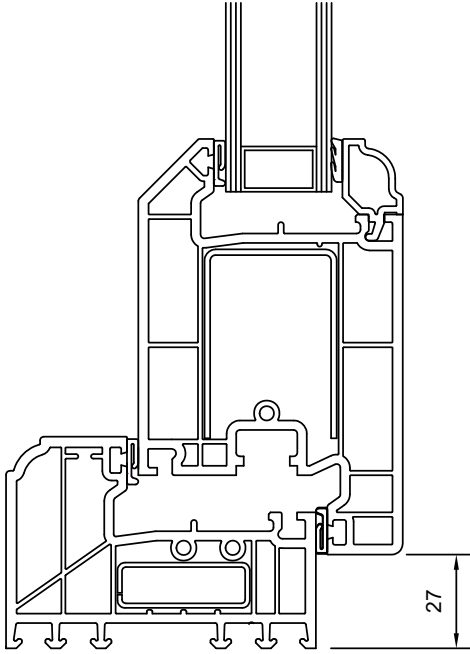

56mm PVC Threshold

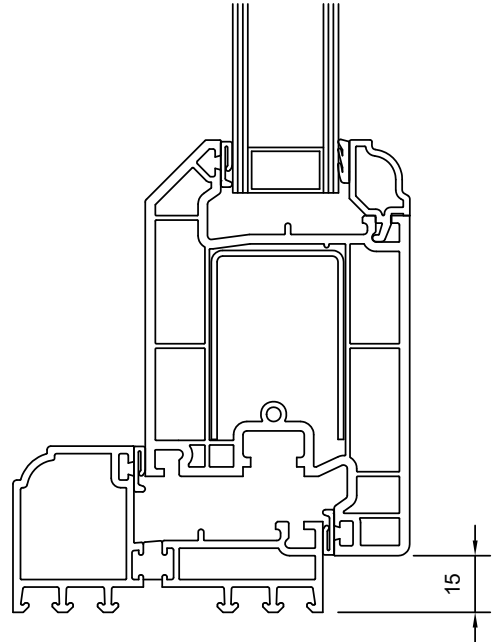

44mm Aluminium Threshold

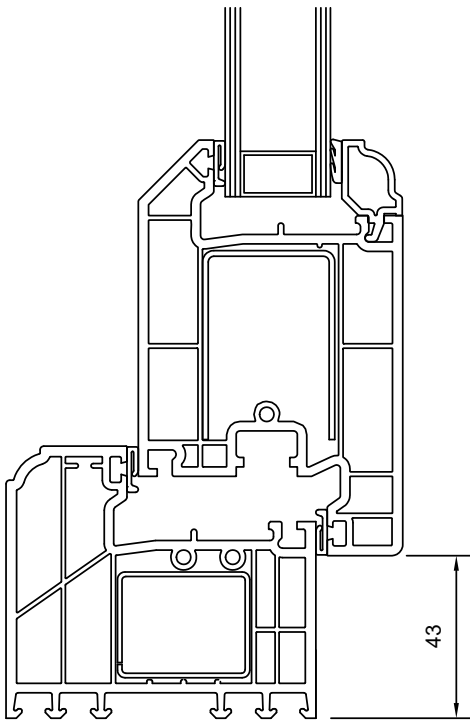

72mm PVC Threshold

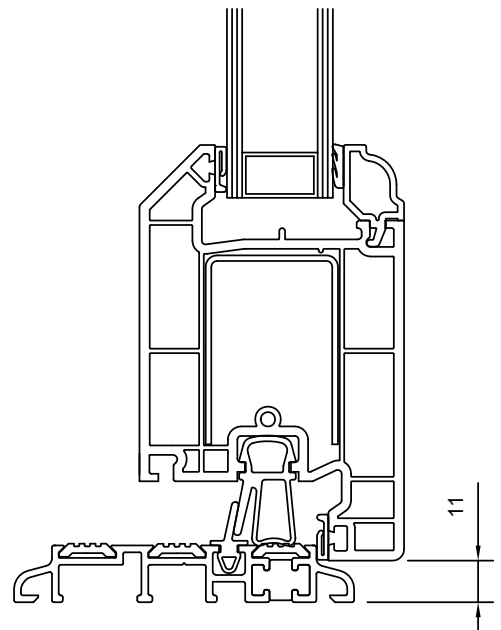

Part M Aluminium Threshold
Not available for use on French Doors
Cannot be guaranteed against air and water infiltration

SECTION A

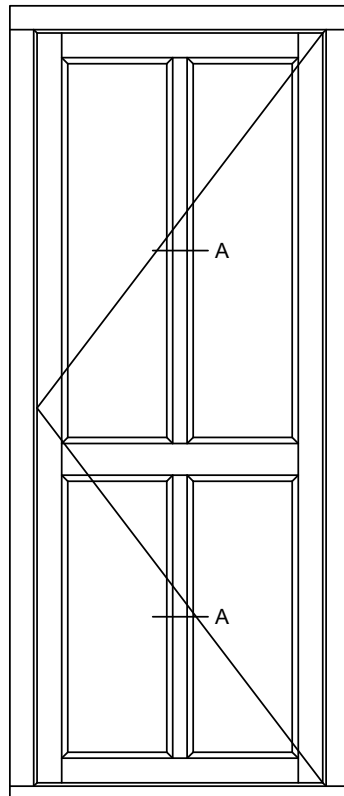
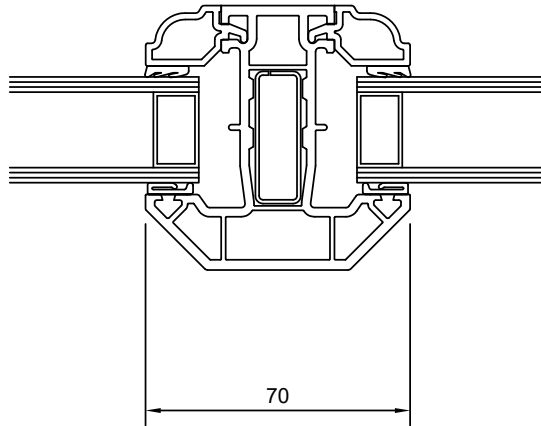

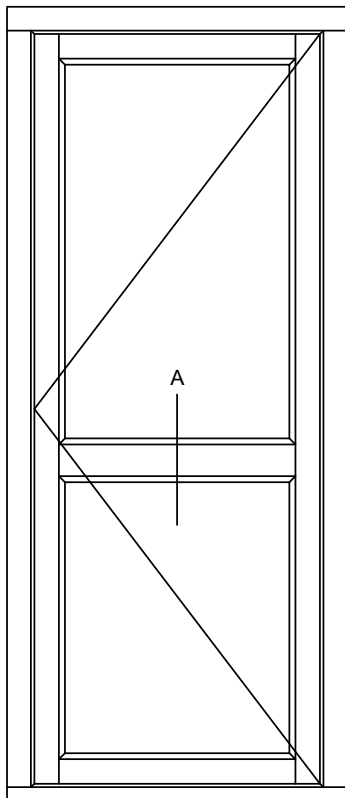

SECTION A

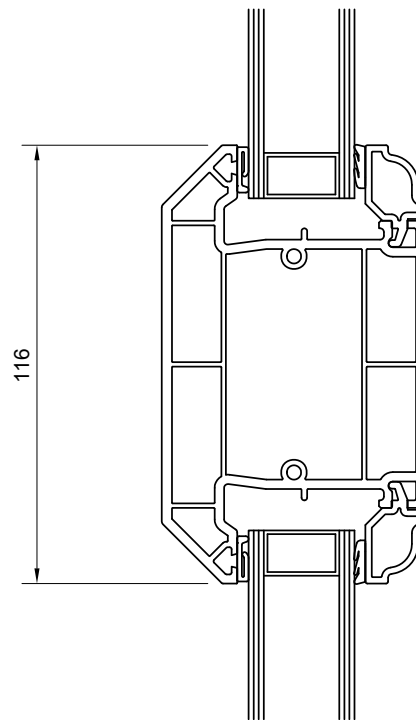

SECTION A

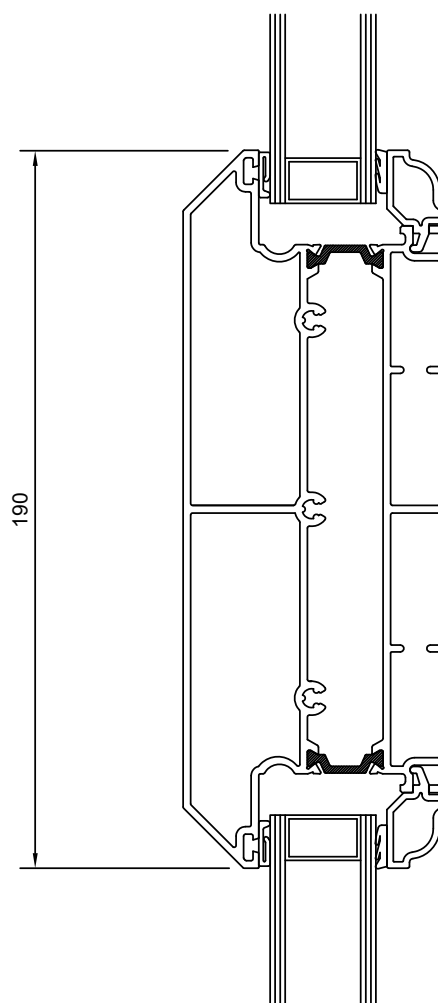
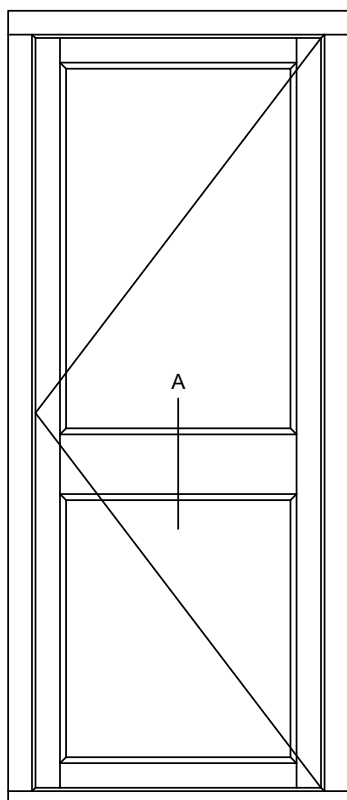

Please note.
This part is manufactured from thermally broken aluminium covered with our standard woodgrain foil.
Standard finish is white internally with very limited options for alternative internal foil colours.
The 190mm mid rail can be sprayed.

SECTION A

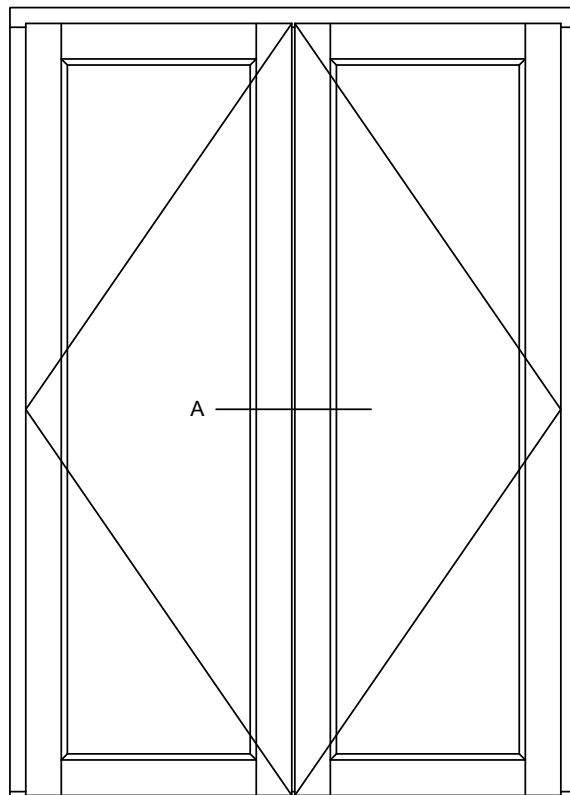
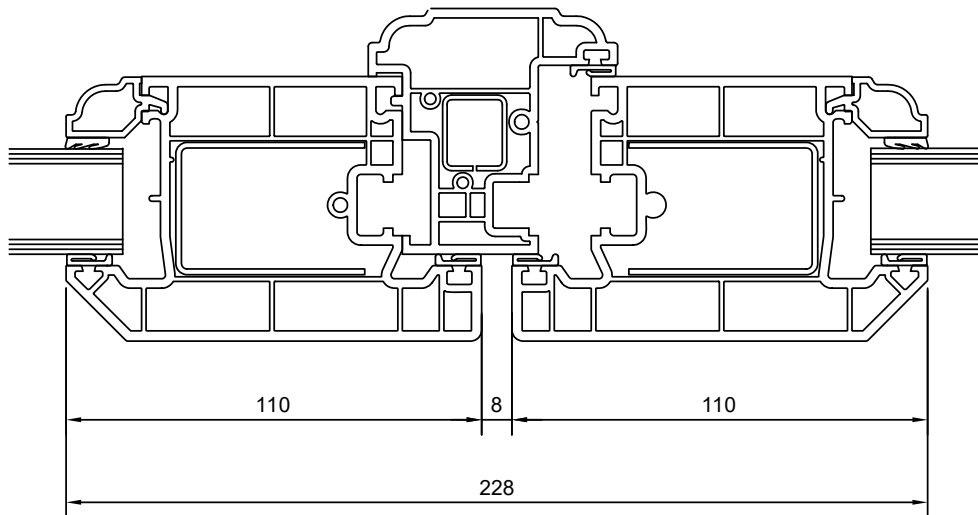

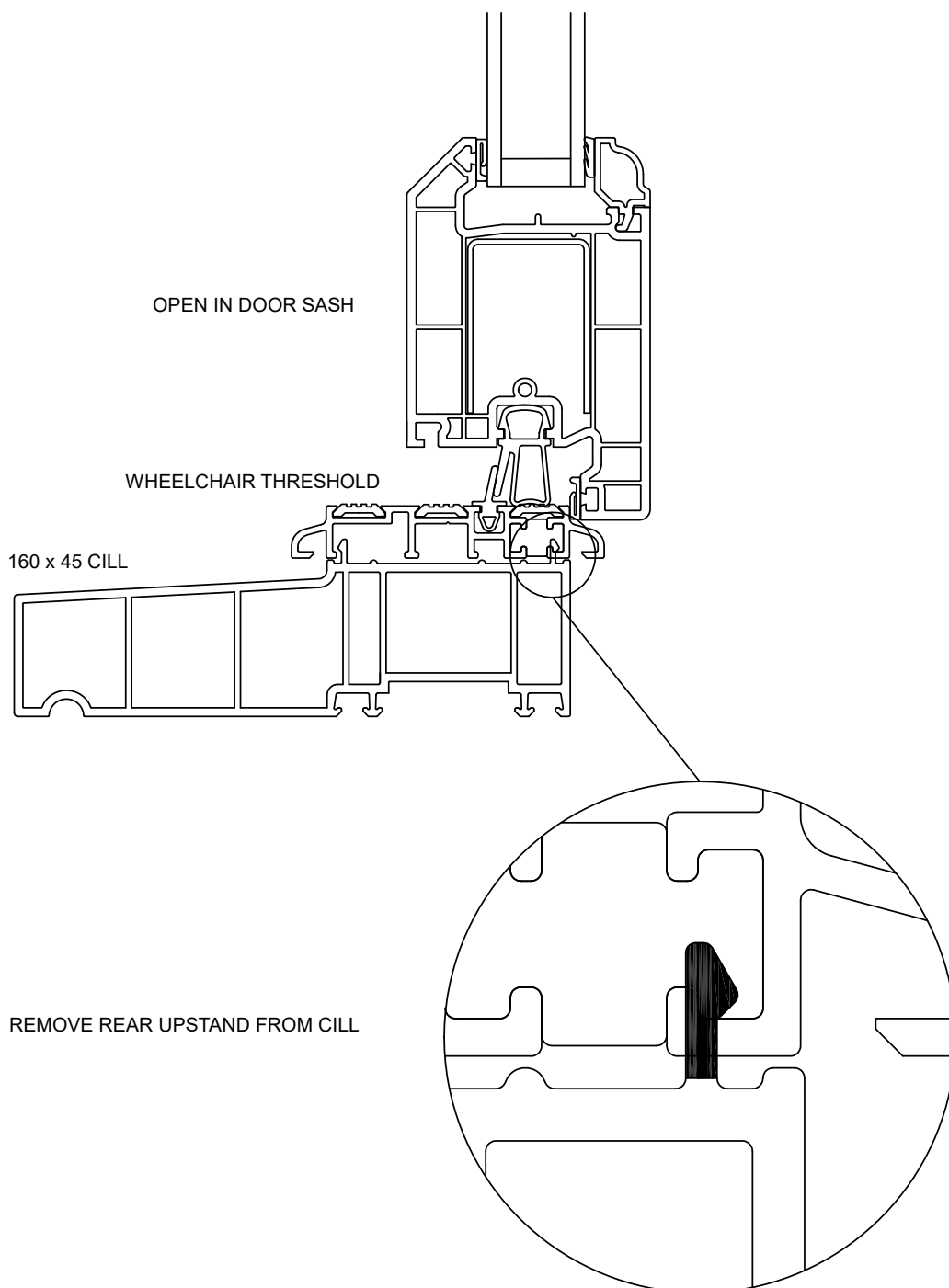

CALCULATION:

Overall Frame width (not including Frame Extenders) minus 51mm

EXAMPLE:

Overall Frame Width of 900mm - 51mm = 849mm Door Swing

NOTE:

Part M of the Building Regulations requires a minimum clearance for a wheelchair, through a doorway of 775mm not including handle or weather bar, therefore, the minimum overall door width, not including frame extenders, should be 940mm

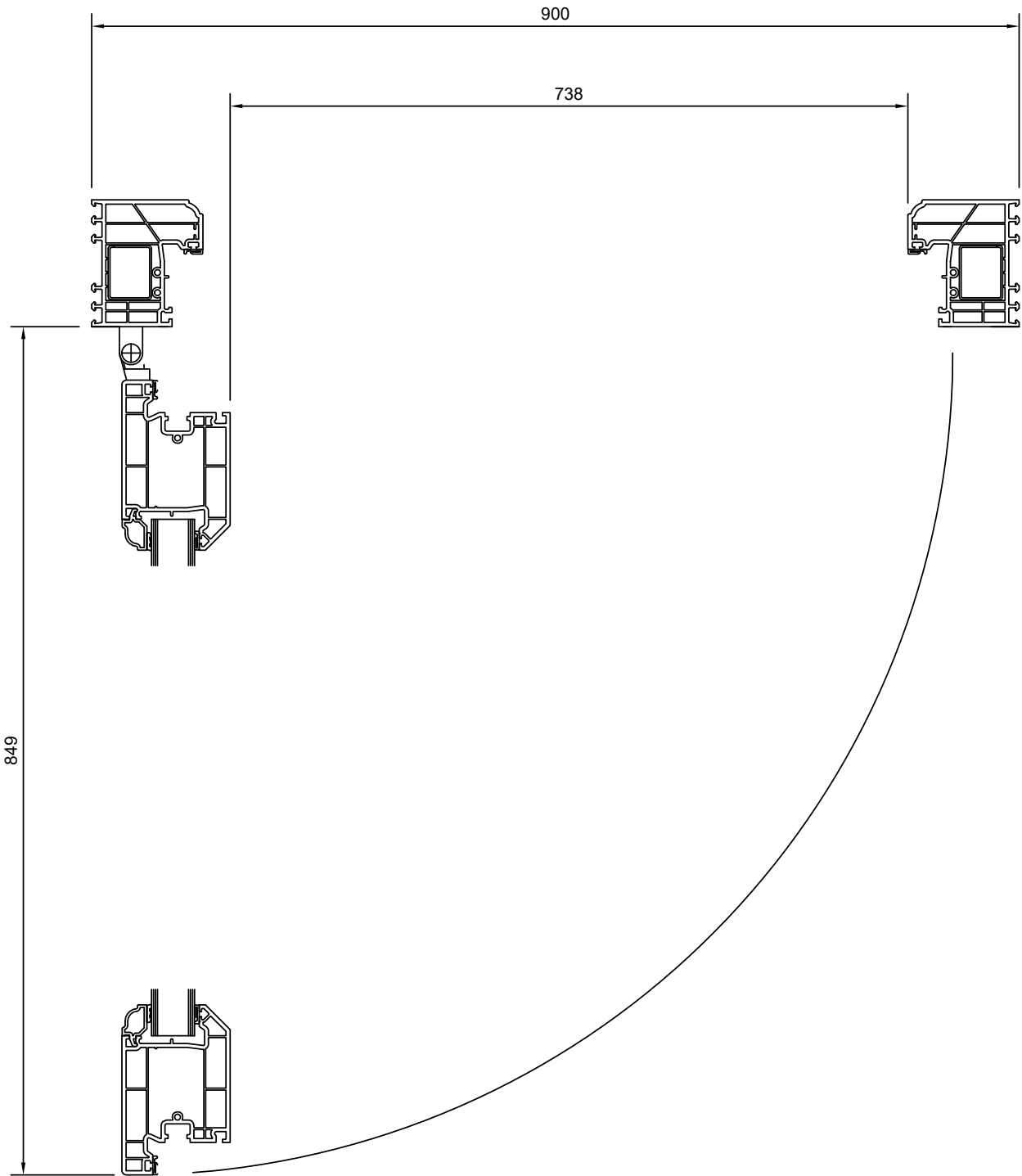

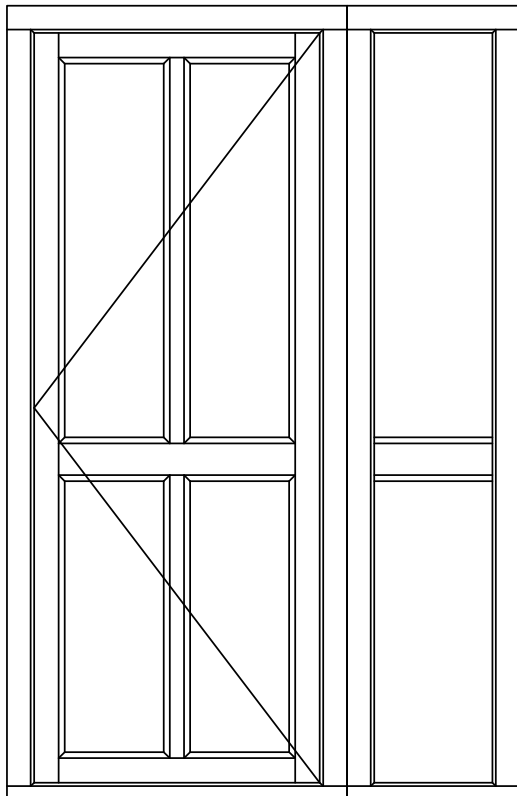

DOOR WITH FULL HEIGHT SIDE PANEL

20mm Coupler Only
Reinforced 72mm or 56mm Outer Frame adjacent to Door

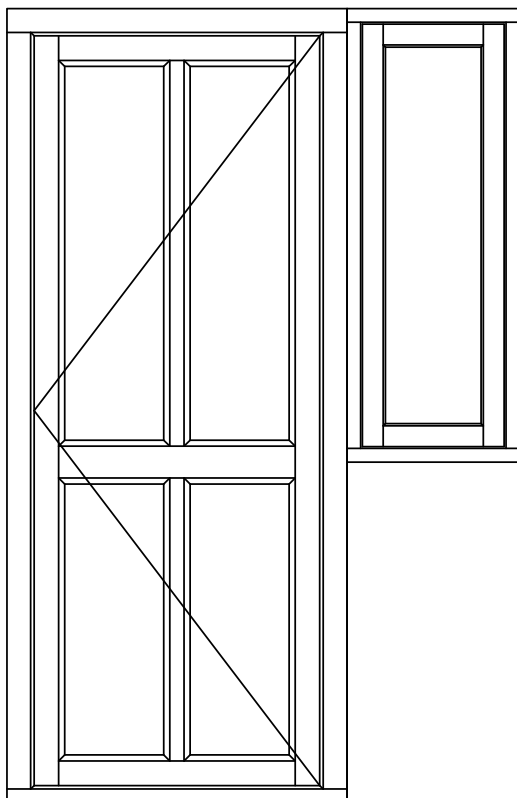

DOOR WITH PARTIAL HEIGHT SIDE WINDOW

20mm or 2mm Coupler
If using 20mm Coupler:
Reinforced 72mm or 56mm Outer Frame adjacent to Door
If using 2mm Coupler:
Reinforced 72mm Outer Frame Only adjacent to Door

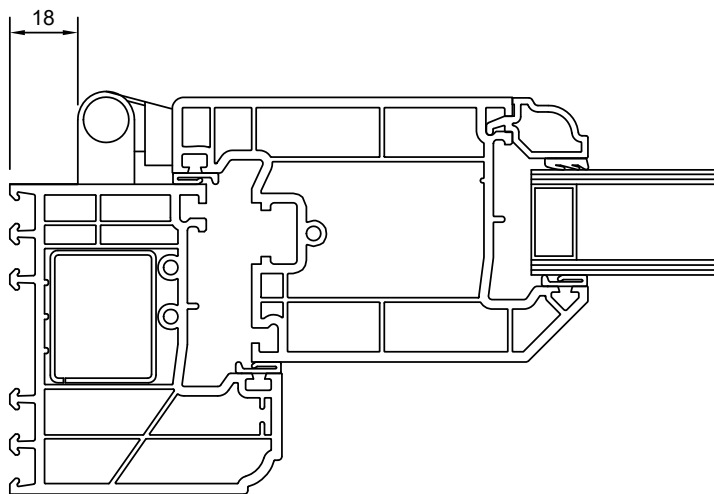

Top of Sash to
Centre of Hinge

160

Hinge Body Height

100

Bottom of Sash to
Centre of Hinge

160

Bottom Hinges can be positioned further up to help clearance of large skirtings etc.

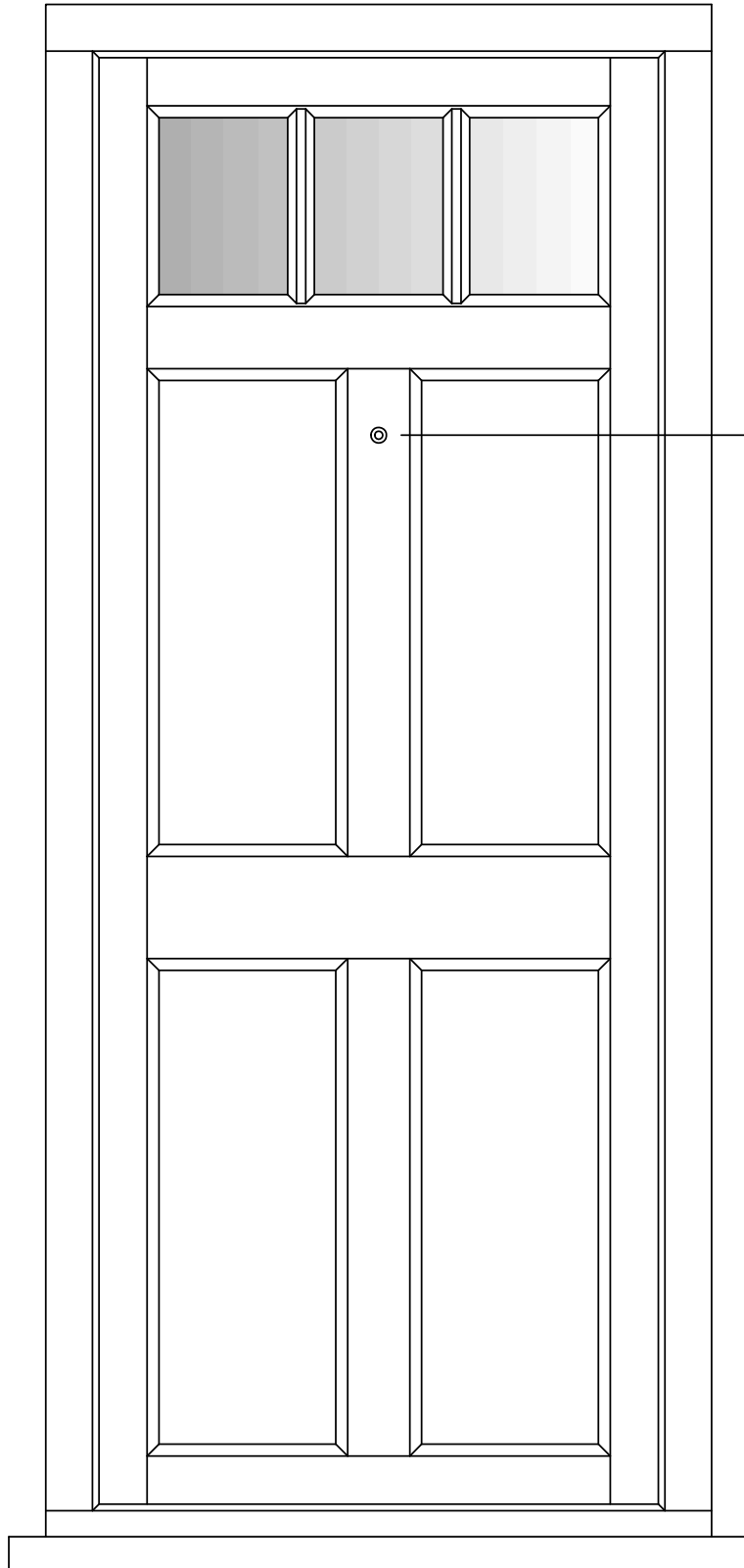

If a Spyhole is requested with an EDC door, a height from the underside of the door outer frame must be provided. Otherwise, the Spyhole will be supplied loose for positioning and fitting on site by the installer. To aid installation, reinforcing will be omitted from the vertical mullion section.

Spyhole Height

28mm Double Glazed - 4/20/4

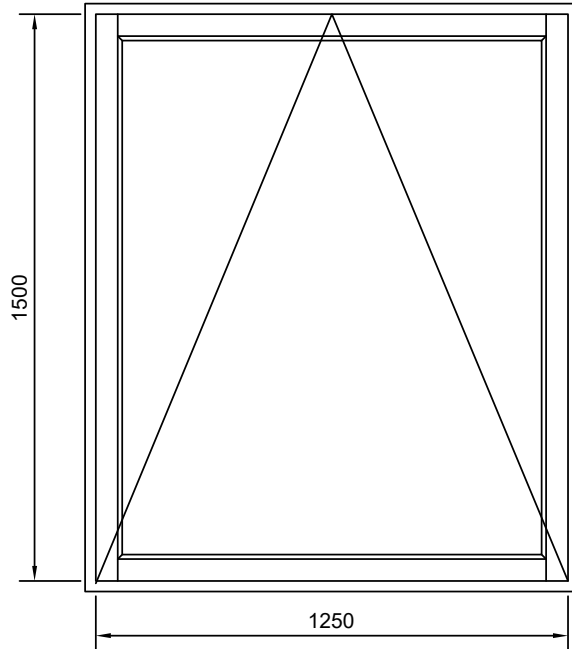
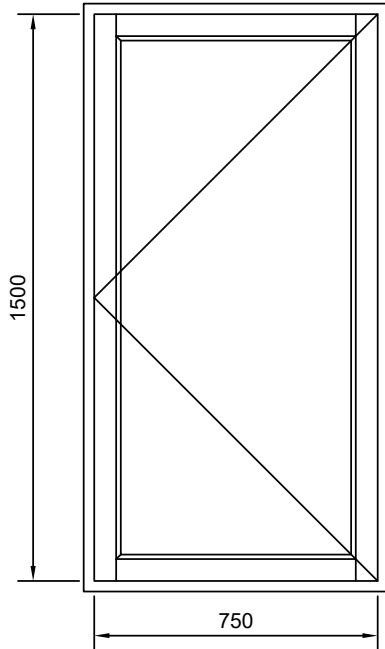

32mm Triple Glazed - 4/10/4/10/4
or
28mm Double Glazed - 6/16/6

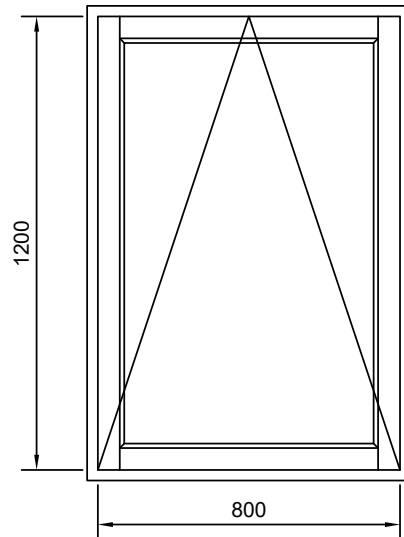
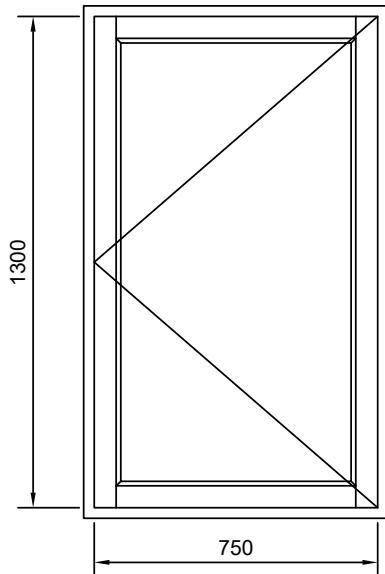

Or 1200 width x 800 height

28mm Double Glazed - 4/20/4

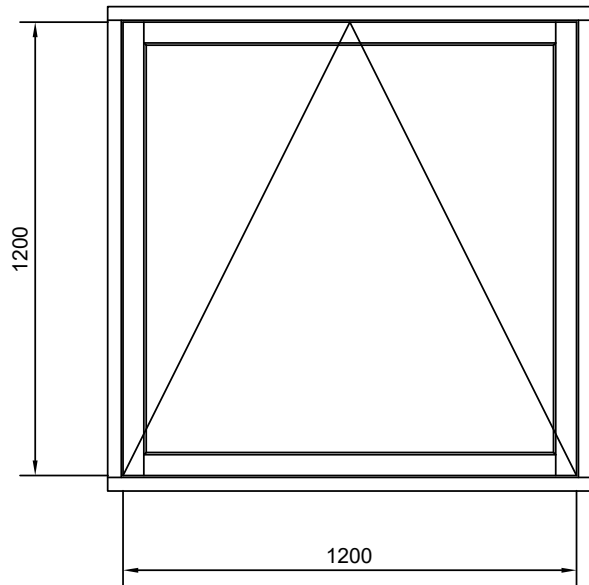
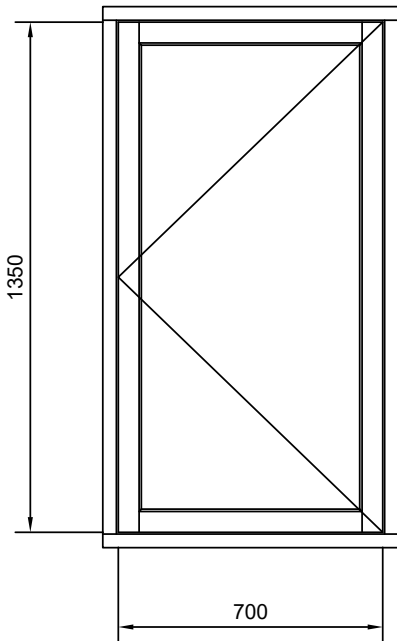

32mm Triple Glazed - 4/10/4/10/4
or
28mm Double Glazed - 6/16/6

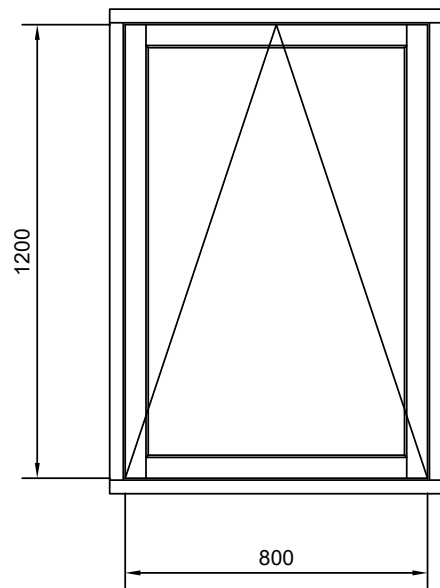
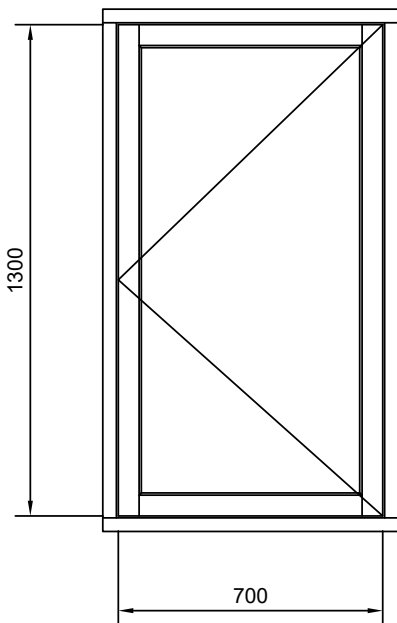

Or 1200 width x 800 height

STORM 1 & 2

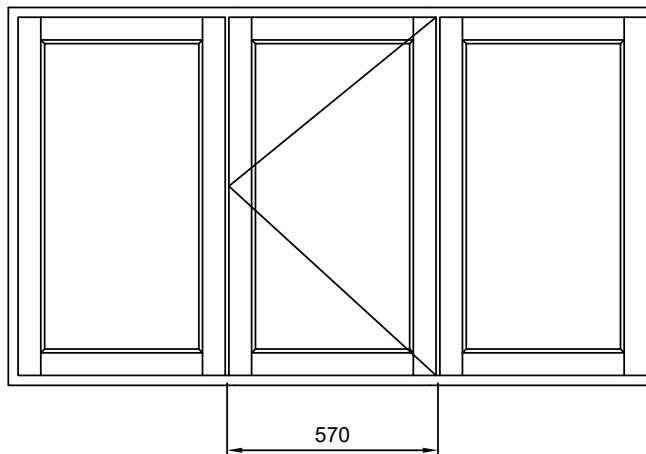
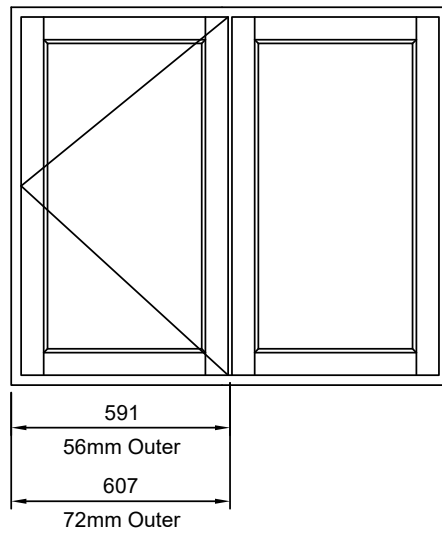
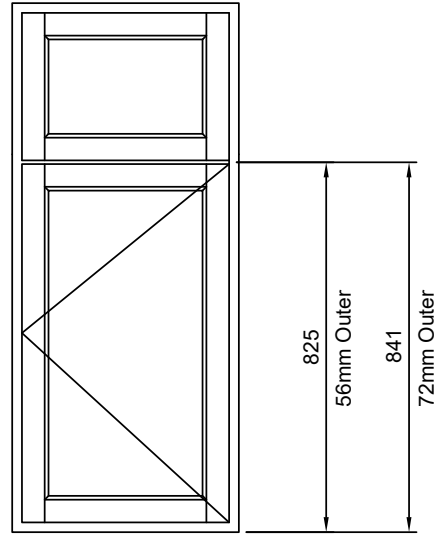
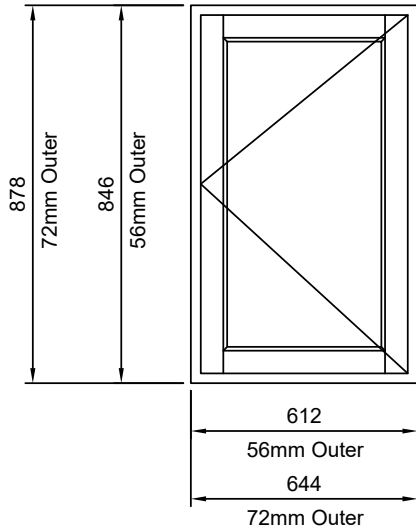

FLUSH

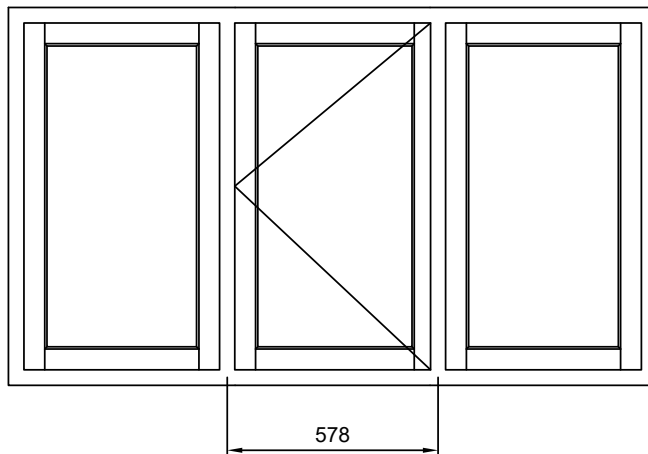
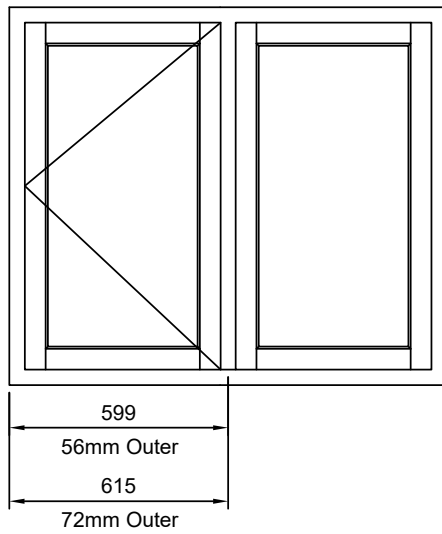
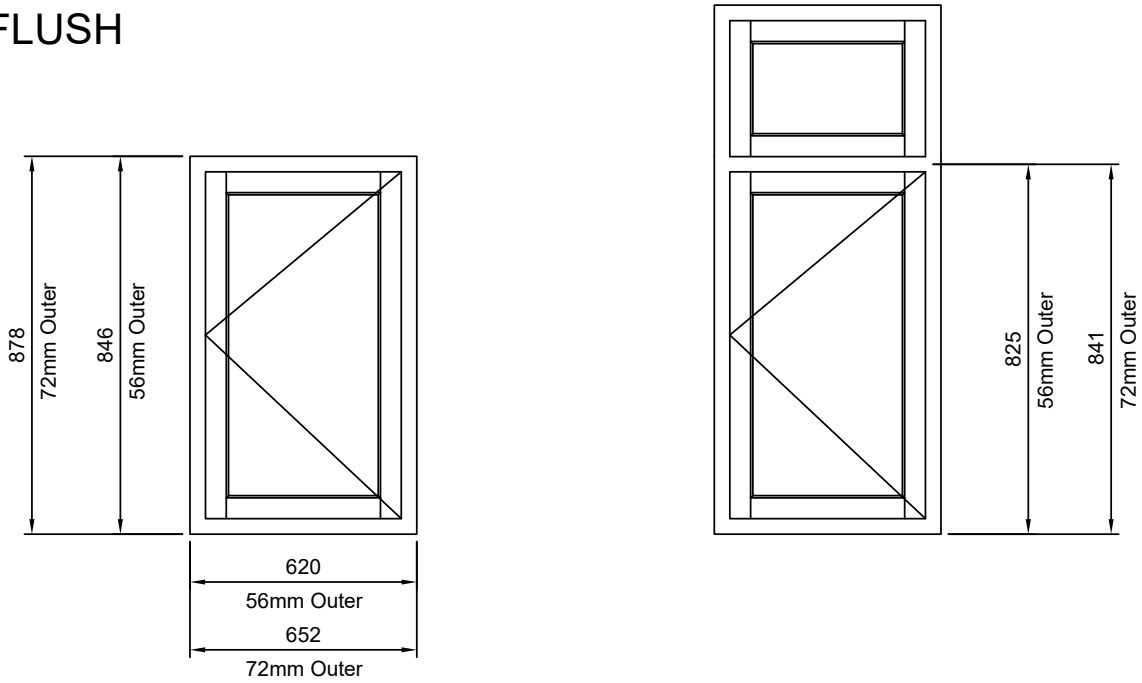

STORM 1 & 2

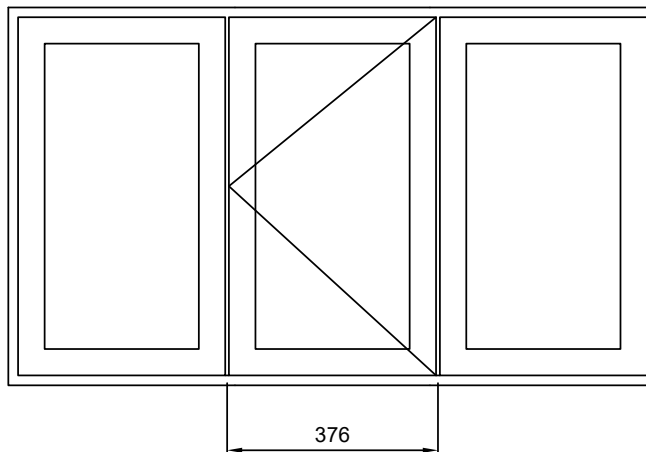
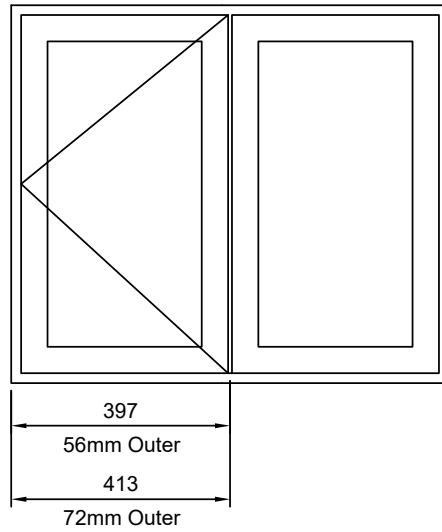
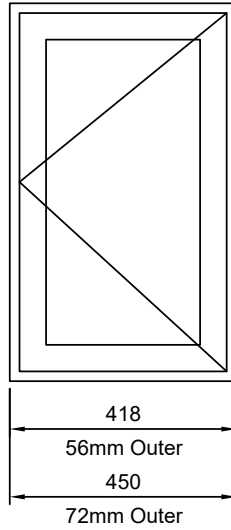

FLUSH

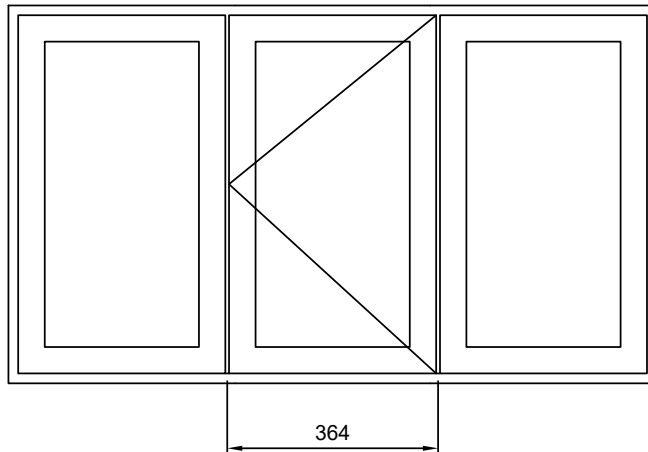
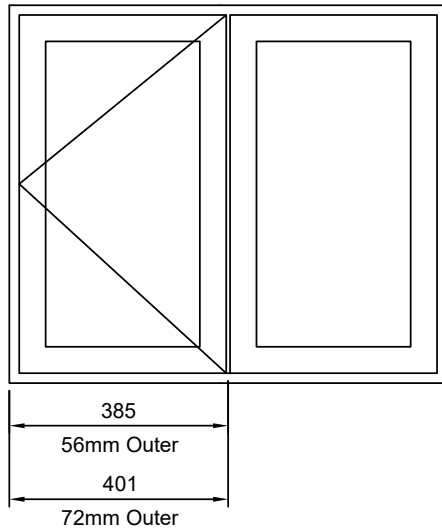
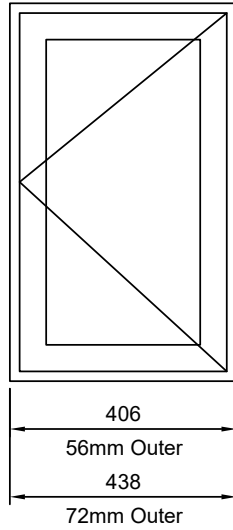

STORM SASH - P90208 - Sizes shown in brackets will be as displayed in Window Designer

WIDTH: 331mm (336mm)

HEIGHT: 331mm (336mm)

FLUSH SASH - P10527 - Sizes shown in brackets will be as displayed in Window Designer

WIDTH: 324mm (329mm)

HEIGHT: 301mm (306mm)

MINIMUM TRANSOM DROPS FOR 'TIMBERLOOK' SASHES

Storm 2 - 56mm Head

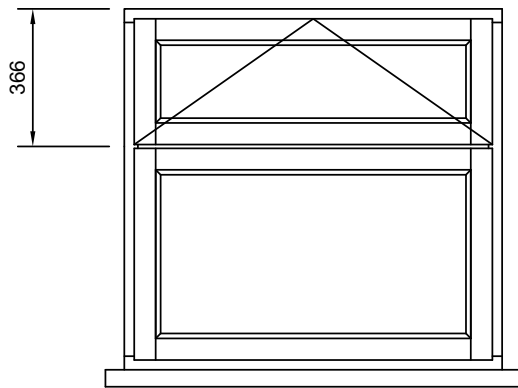

Flush - 56mm Head

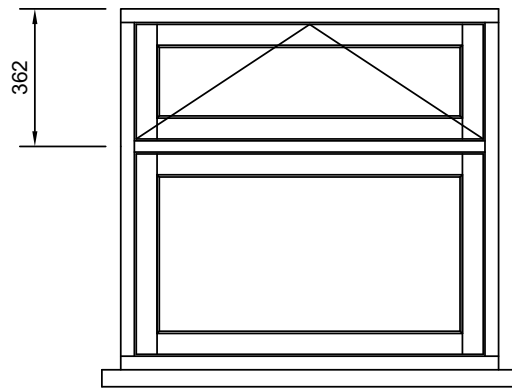

Storm 2 - 72mm Head

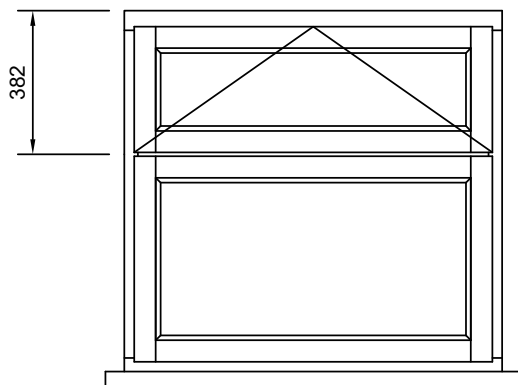

Flush - 72mm Head

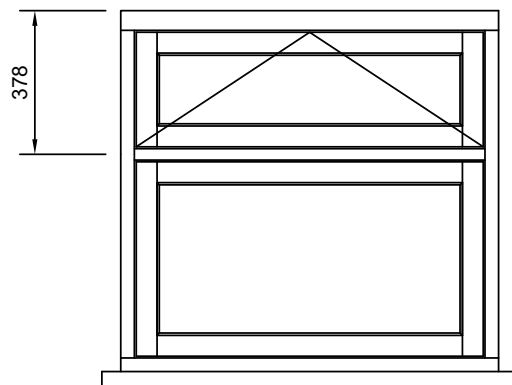

MAXIMUM SIZES

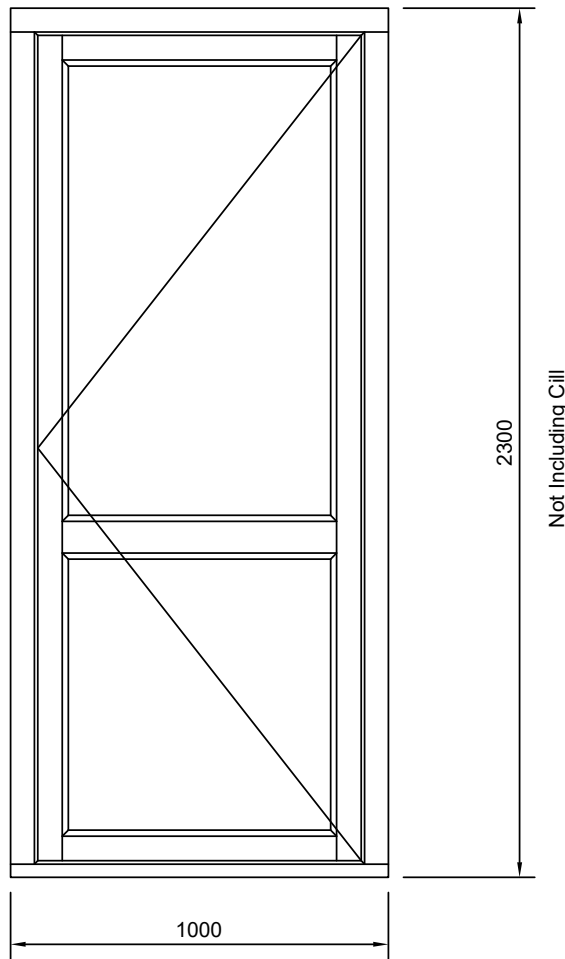

MINIMUM SIZES

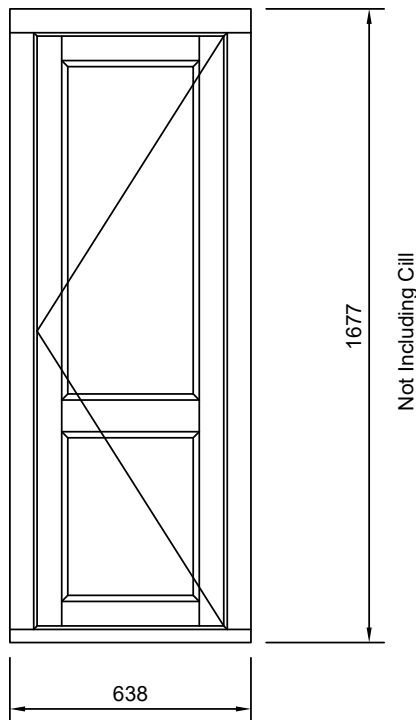

DIMENSIONS SHOWN ASSUME THE USE OF 72mm HEADS & SIDES AND 44mm THRESHOLDS
DIMENSIONS SHOWN ARE FOR DOORS FITTED WITH STANDARD FULLEX XL LOCKS

MAXIMUM SIZES

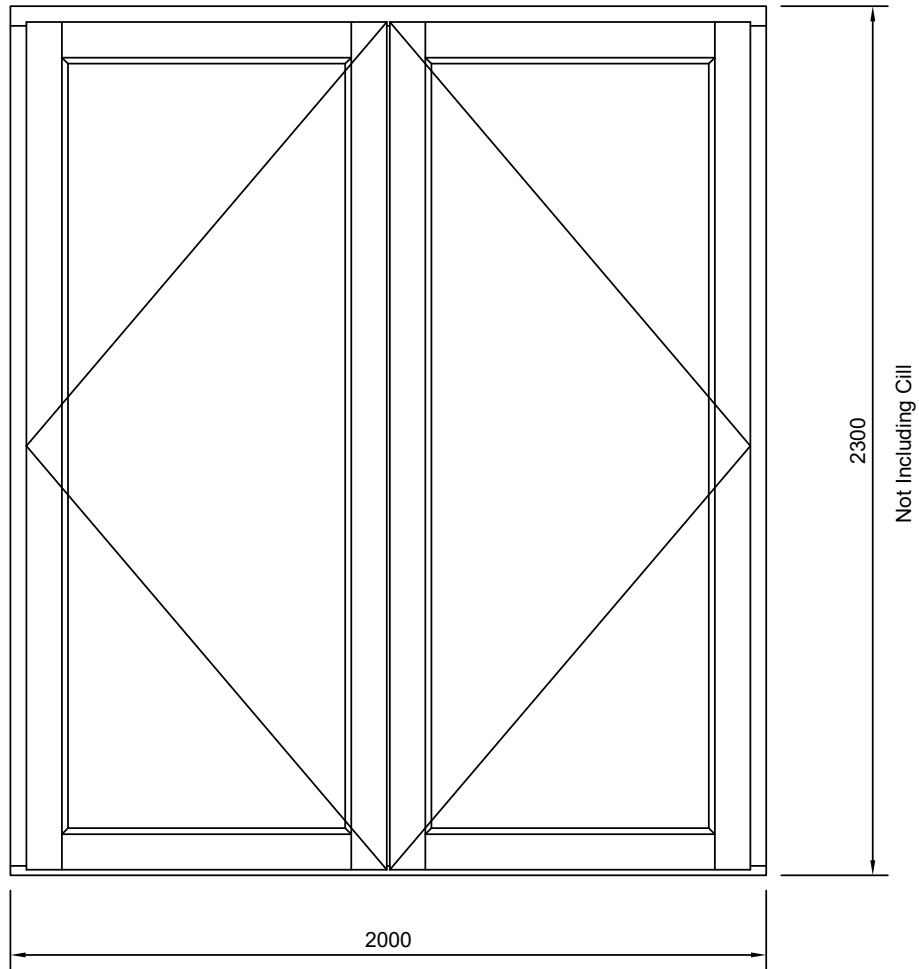

MINIMUM SIZES

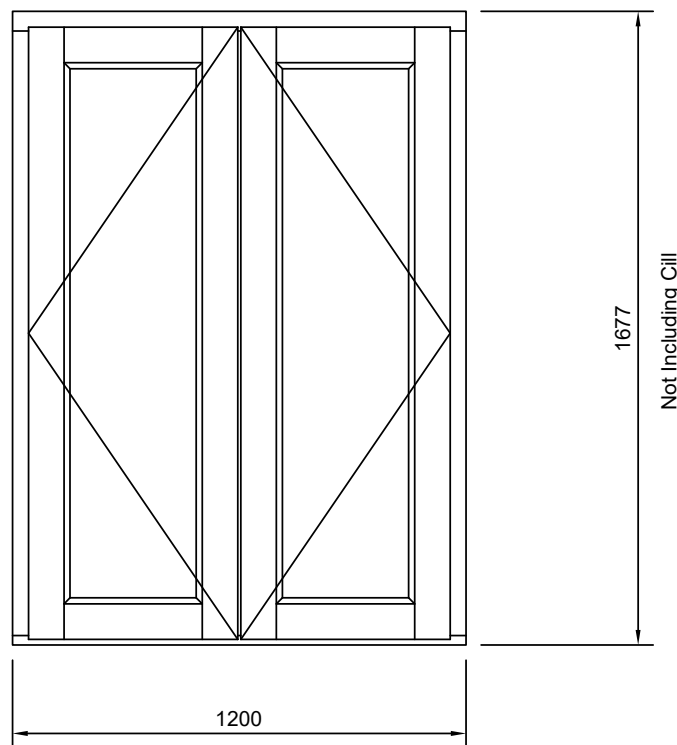

DIMENSIONS SHOWN ASSUME THE USE OF 72mm HEADS & SIDES AND 44mm THRESHOLDS

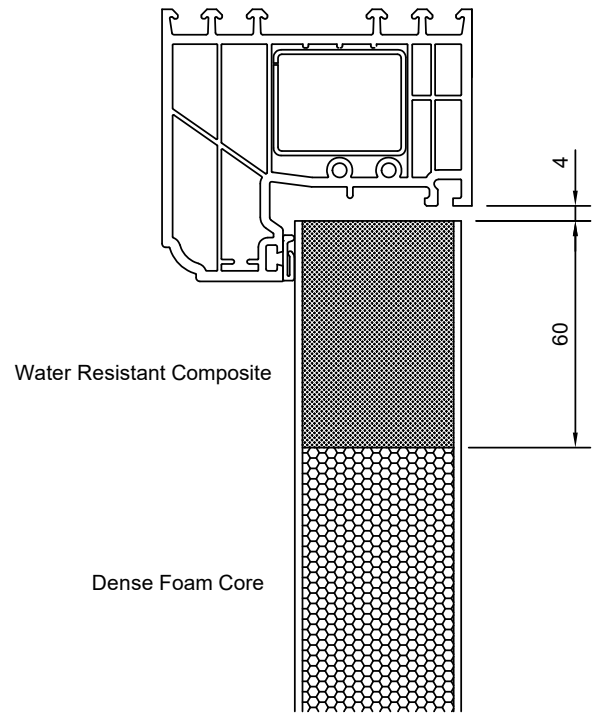
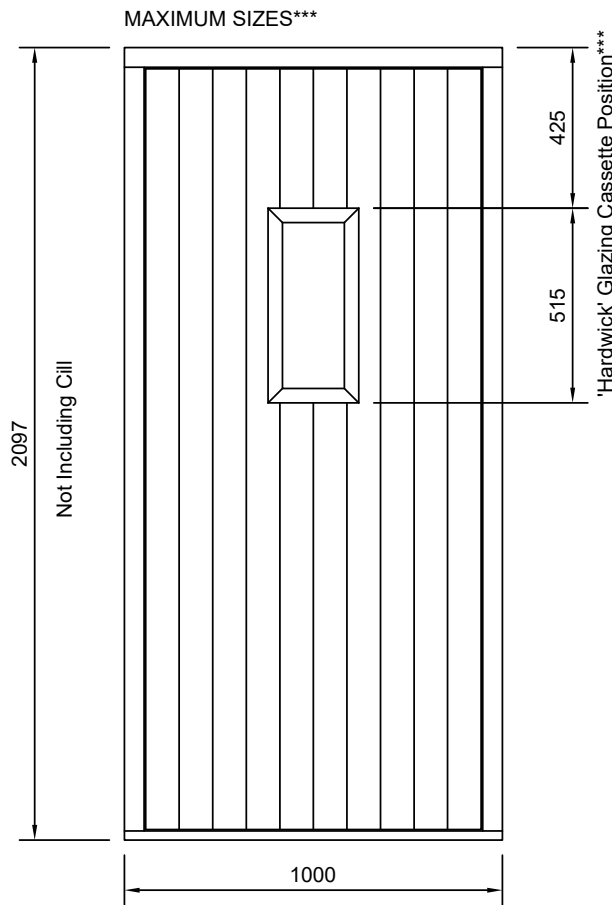

Construction

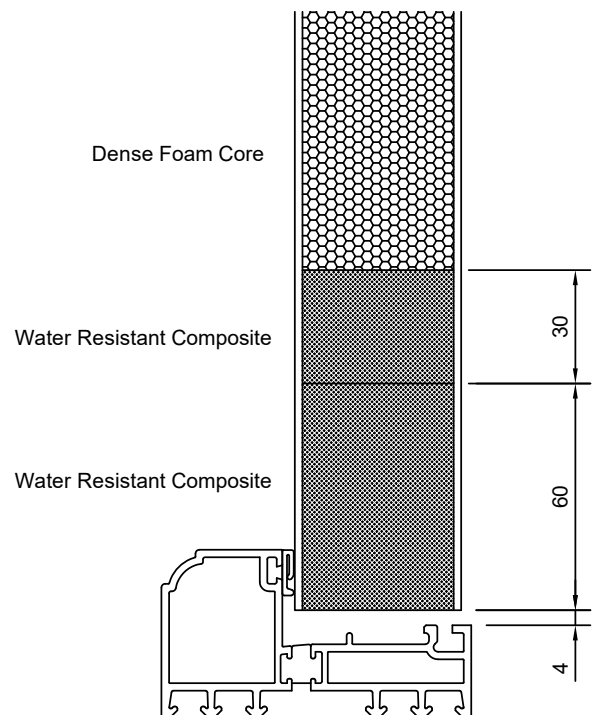
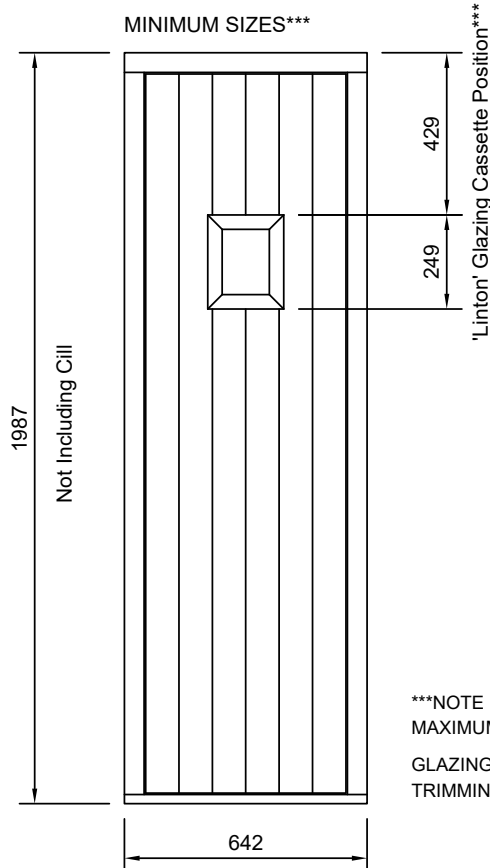

***NOTE
MAXIMUM AND MINIMUM SIZES SHOWN ASSUME 72mm HEAD & SIDES AND 44mm THRESHOLD
GLAZING CASSETTE POSITIONING MAY VARY DEPENDENT UPON REQUIRED
TRIMMING OF COMPOSITE DOOR SLAB AT TOP

MINIMUM DIMENSIONS USING 56mm OUTER FRAME

STORM 1

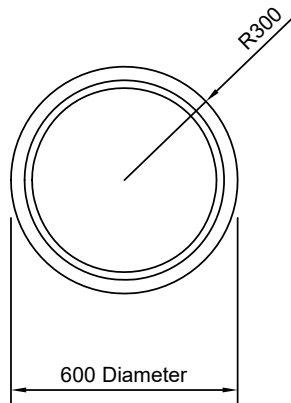

STORM 2

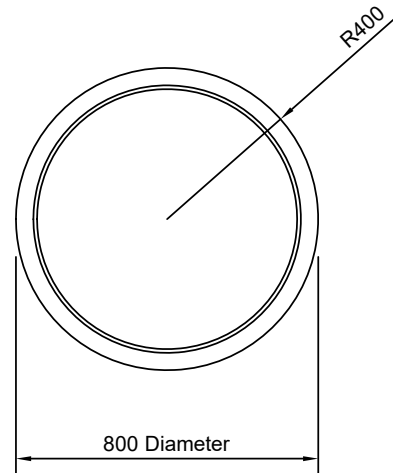

Please Note.

Storm Casement, Door Sash and Flush Casement profiles cannot be curved.

If arched sections are required above windows or doors, these will be manufactured as separate, direct glazed, internally beaded frames and coupled to the item as shown below.

Window frames with curved sections within them will always be conventionally welded.

Semi Circular Toplight Over Door

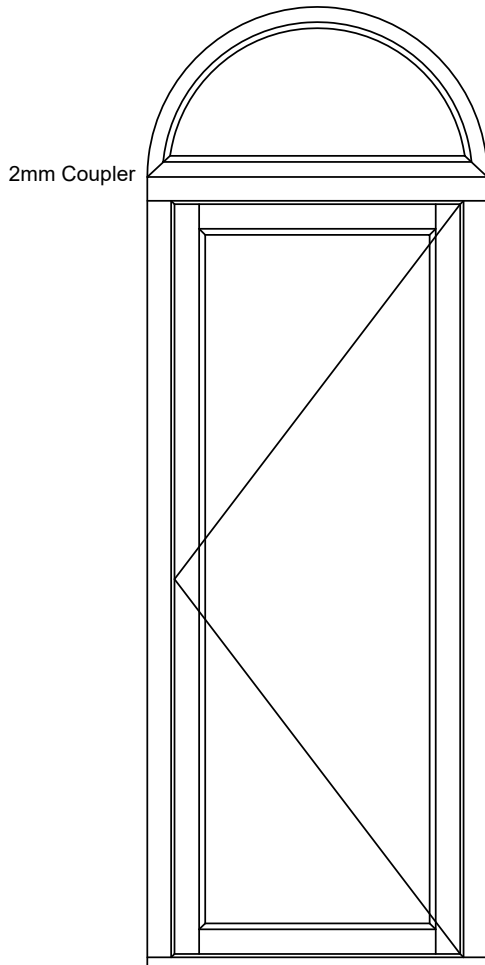

Constant Radius Arch Over Window

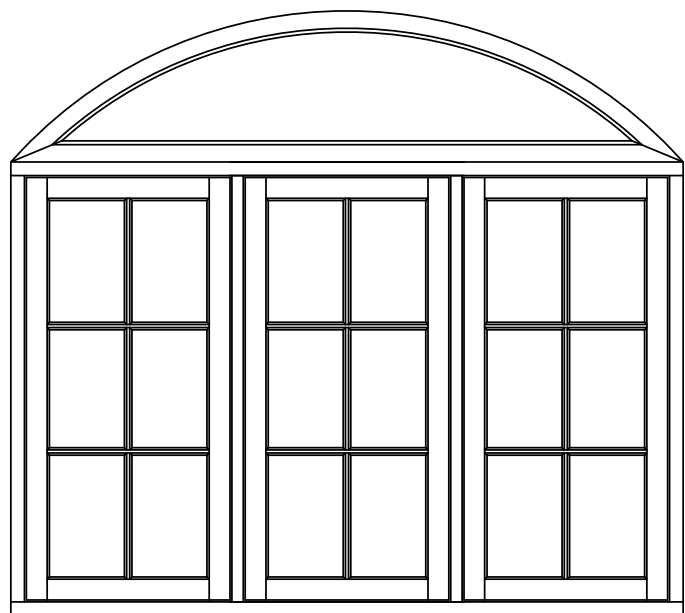

Fab 'n' Fix Nu Mail Letterplate
in 116mm or 190mm Midrail

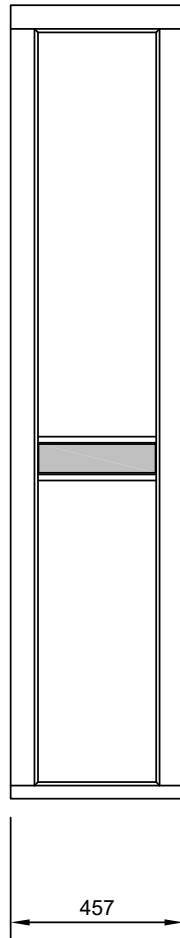

Wrought Iron or Regency Flush
Letterplate in 190mm Midrail
only

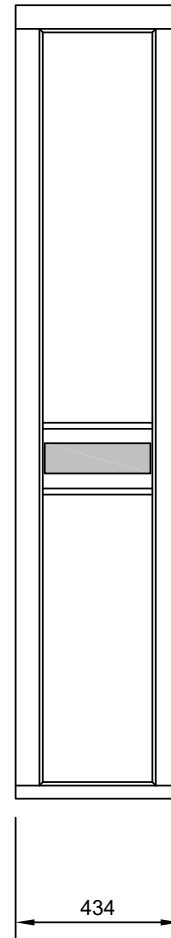

The above dimensions are based on the use of 72mm Outer frames

If using 72mm Outer Frame to one side and 56mm Outer Frame to the other then:

Minimum Side Panel Width for Fab 'n' Fix Nu Mail Letterplate = 441mm

Minimum Side Panel Width for Wrought Iron or Regency Flush Letterplate = 418mm

If using 56mm Outer Frame to both sides then:

Minimum Side Panel Width for Fab 'n' Fix Nu Mail Letterplate = 425mm

Minimum Side Panel Width for Wrought Iron or Regency Flush Letterplate = 402mm

If required to meet Fire Egress Regulations with a Top Hung Sash, this can only be achieved with the use of a standard 16" Side Hung Hinge used as a Top Hung Hinge which will open to 85°

A minimum height of 790mm from the underside of the Outer Frame to the centre of a Transom as shown is required or, 816mm if Outer Frame to Outer Frame.

Also, the minimum width of the Window using standard 56mm Outer Frame will need to be 846mm to achieve the required clear opening area of 0.33m².

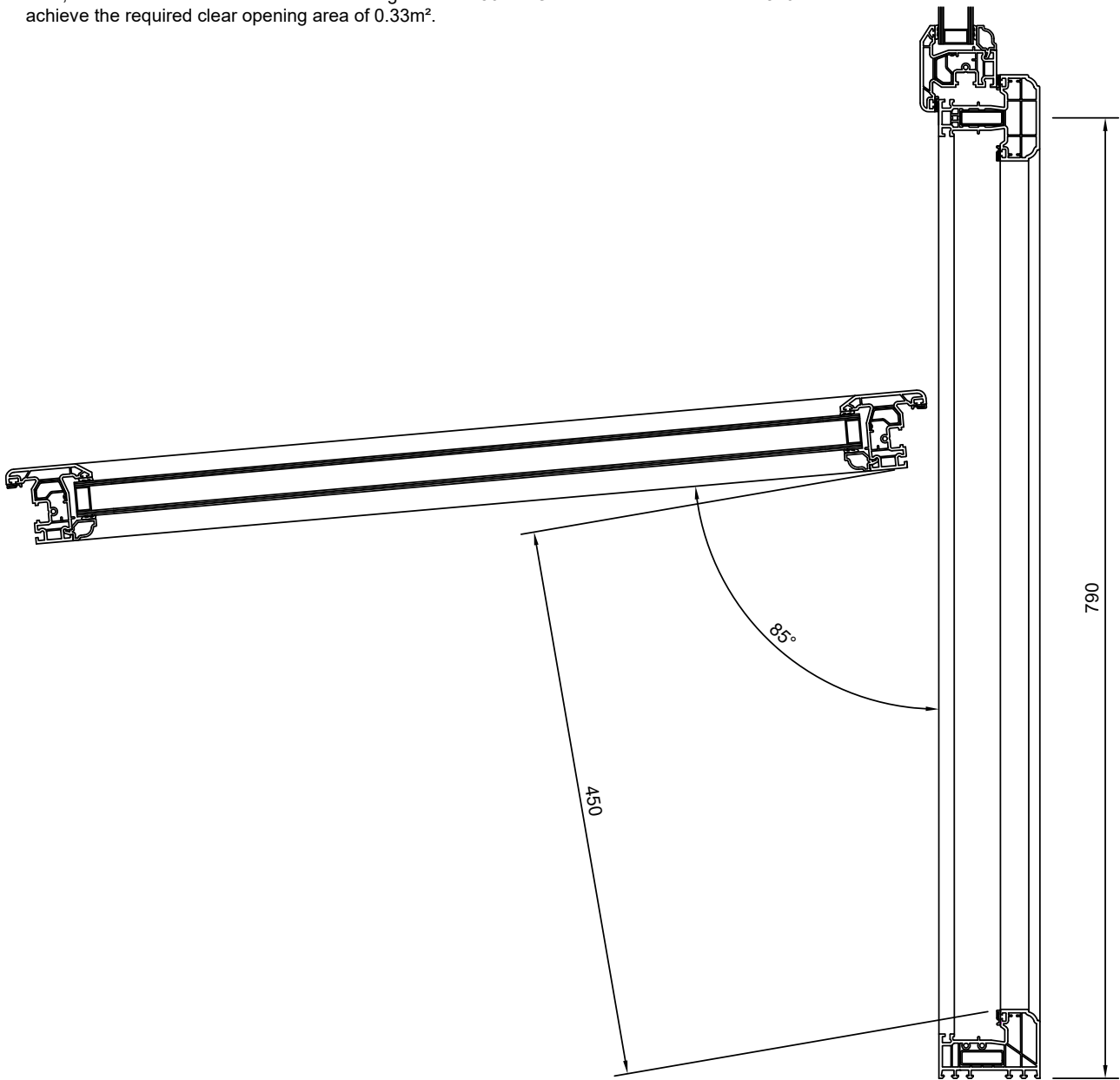

2mm COUPLING - Example Shown: Flush Casement in 56mm Outer Frame to Flush Casement in 56mm Outer Frame

2no. Couplers Required per frame join

116 217 Storm 2 2mm Coupler

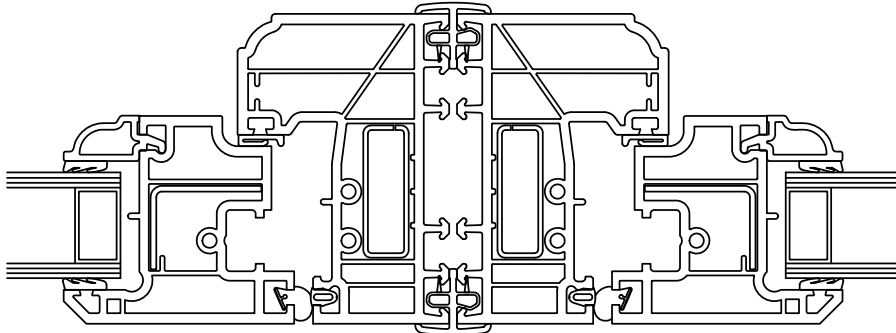

116 217 Storm 2 2mm Coupler

20mm HEAVY DUTY COUPLING - Example Shown: Direct Glazed 72mm Outer Frame to 72mm Door Outer Frame

For Vertical use only - Maximum length: 2500mm

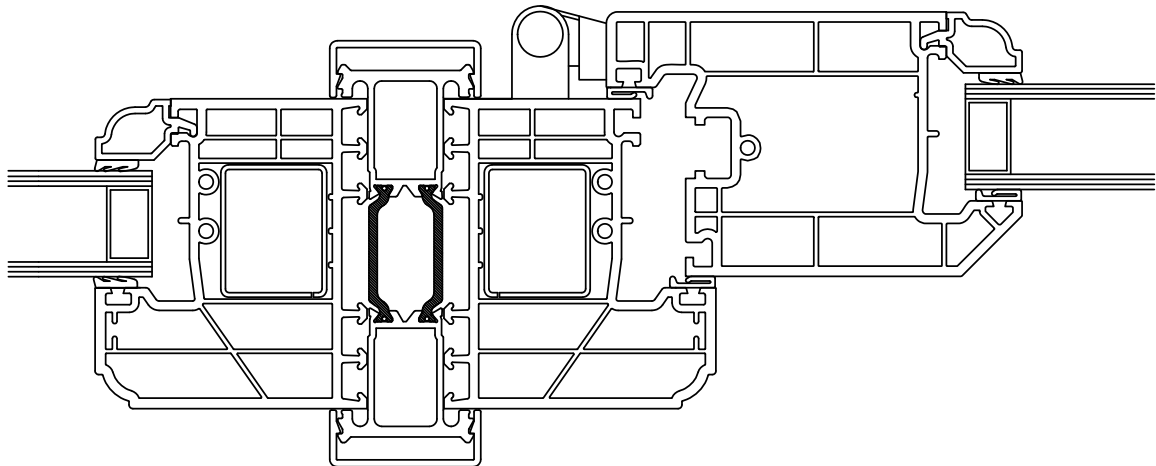

A00434 20mm Storm 2 Heavy Duty Coupler

P10323 Plain Covers External & Internal

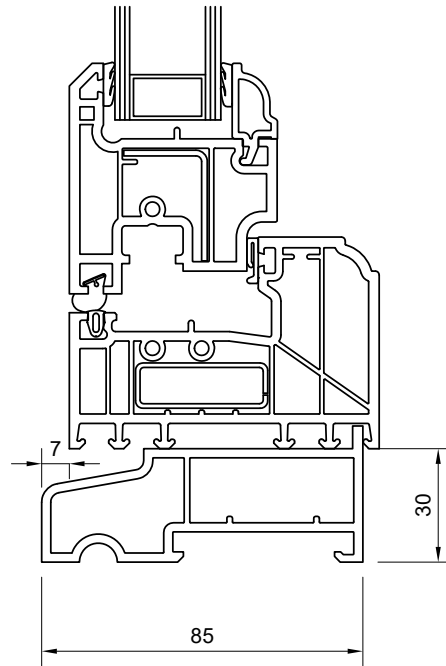

P90039 85mm Cill

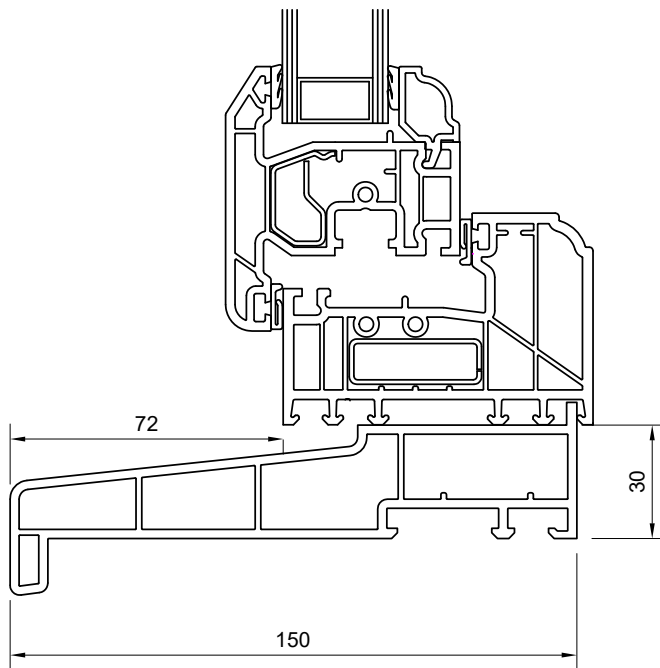

P90042 150mm Cill

The Storm 2 Outer Frame Profile has been designed to be used in conjunction with the 160mm x 45mm and 200mm x 45mm Timberlook Cills.

If a job requires the use of the Storm 1 30mm Cill sections, please see above for the positioning of the Cill relative to the Outer Frame.

If the Cill is positioned with its upstand behind the Outer Frame, the front edge of the Outer Frame will not be supported by the flat bed of the Cill.

Welded Bay Cill sizes are manually adjusted to allow the 30mm Cill to sit in the same position as shown above.

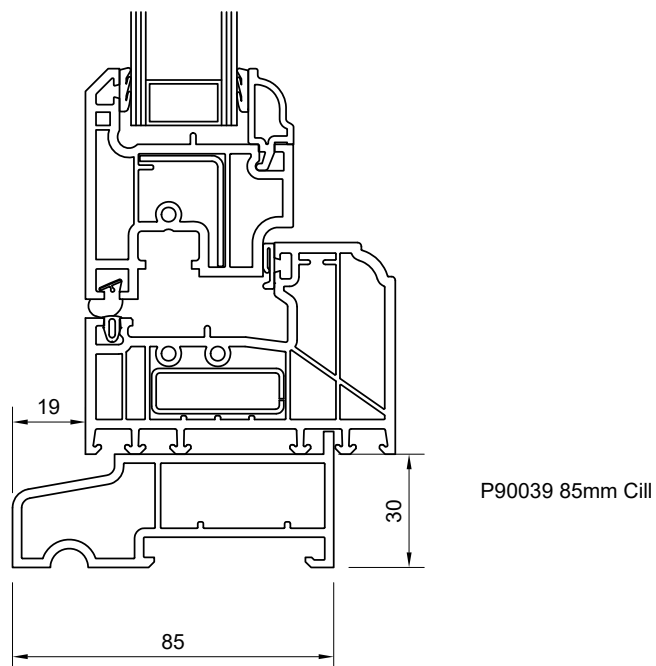

The Storm 2 Outer Frame Profile has been designed to be used in conjunction with the 160mm x 45mm and 200mm x 45mm Timberlook Cills.

If a job requires the use of the Storm 1 30mm Cill sections, please see above for the positioning of the Cill relative to the Outer Frame.

If the Cill is positioned with its upstand behind the Outer Frame, the front edge of the Outer Frame will not be supported by the flat bed of the Cill.

Welded Bay Cill sizes are manually adjusted to allow the 30mm Cill to sit in the same position as shown above.

The 85mm Cill can also be positioned further forward as shown above without compromising the Outer Frame Concealed Drainage.

When a 160mm x 45mm or 200 x 45mm Cill requires a straight (180 degree) join, a section of 2mm coupler is fabricated by cutting and bending it as shown in the illustration.

Portions of the 2mm Coupler are removed to allow clearance of the coupler round the internal ribs of the Cill.

An additional section of 2mm Coupler is fitted to the back edge of the cill to conceal the join.

Section mitred then bent to form front edge

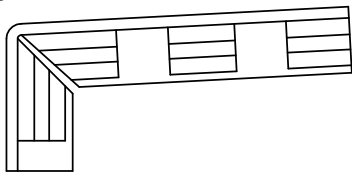

Standard 2mm Coupler section



Shaded portions of 2mm Coupler removed where shown, to avoid internal ribs of Cill

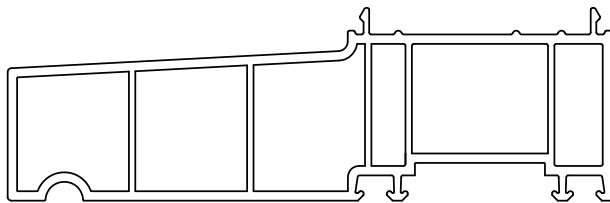

Additional section of 2mm Coupler required to back edge of Cill

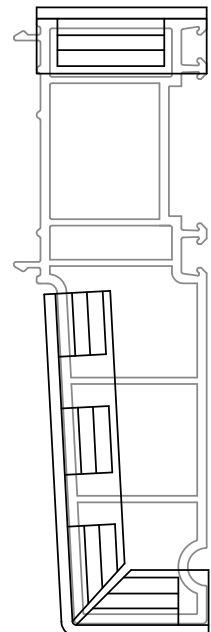
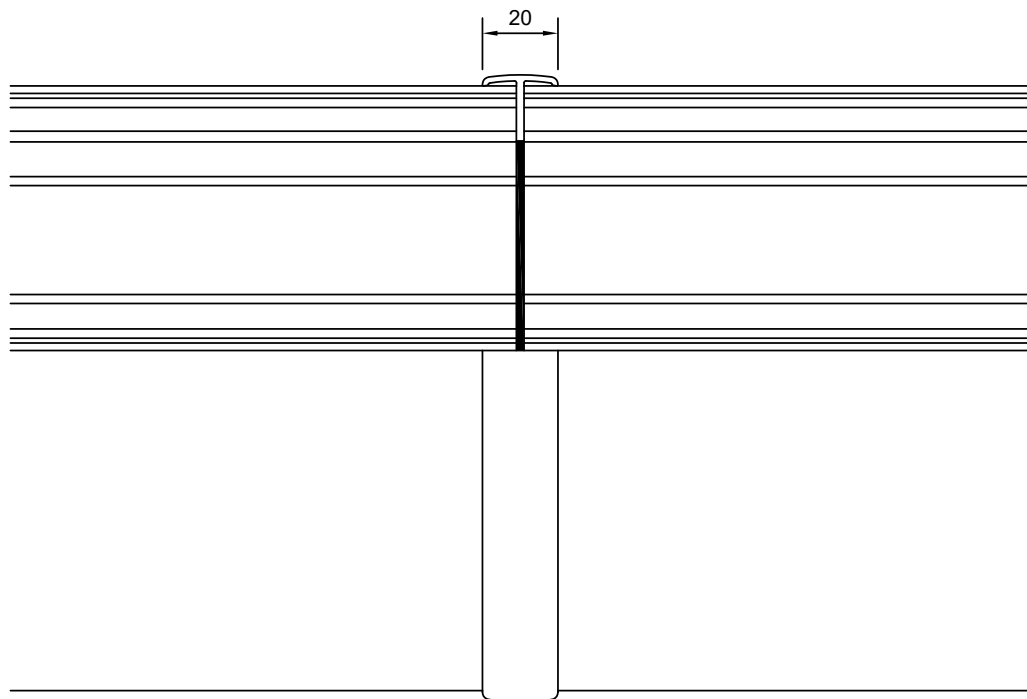

STORM & EDC DOORS

FLUSH CASEMENT

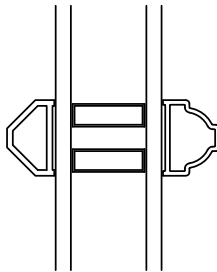

20mm PUTTY / OVOLO

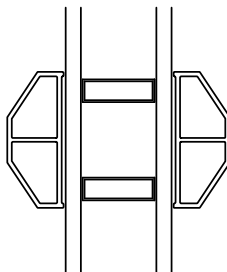
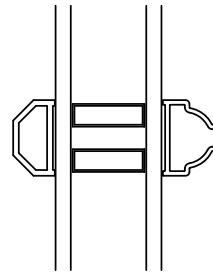

36mm GEORGIAN BAR

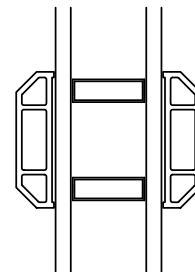

P10191
20mm Georgian Bar
External - Putty Line - Storm



P10193
20mm Georgian Bar
External - Putty Line - Flush



P90123
20mm Georgian Bar
Internal - Ovolo - Storm & Flush



EV03
36mm Georgian Bar
External & Internal - Storm

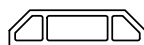

709021
36mm Georgian Bar
External & Internal - Flush

When ordering replacement Georgian bars for existing windows the following naming convention as shown on the example Storm 2 window below must be followed to avoid confusion and to ensure that the correct Georgian bar is supplied to the right length and with the correct end milling. These measurements are what Evolution call 'Shoulder to Shoulder' sizes.

State whether the window is Storm or Flush Casement or Storm Door and what width of Georgian bar is required, either 20mm or 36mm.

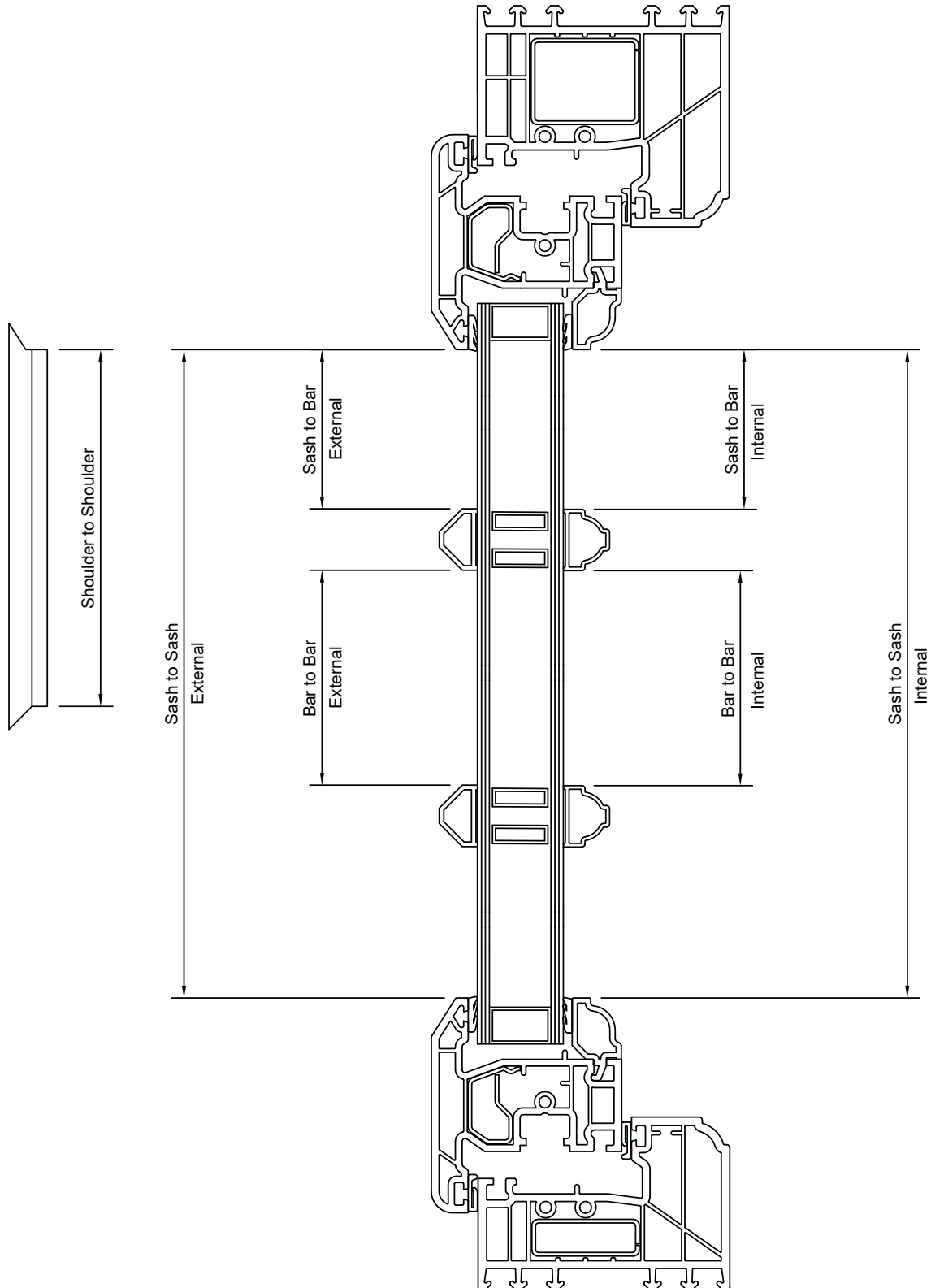

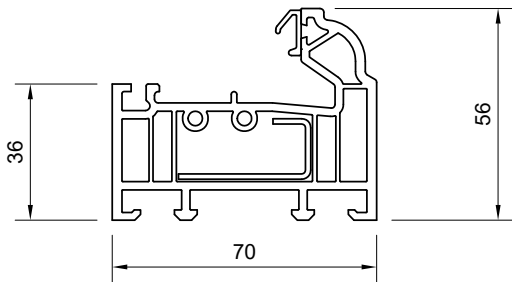

P10531 Storm 1 56mm Outerframe
AE1835GS/3 Reinforcing

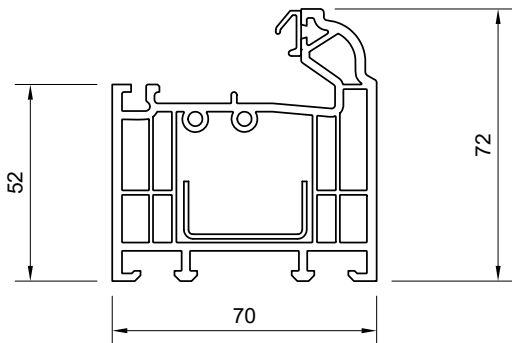

P10532 Storm 1 72mm Outerframe
S41101 Reinforcing

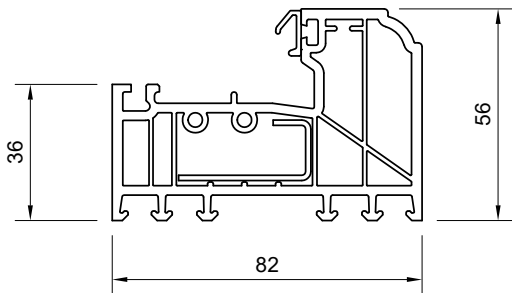

P90201 Storm 2 56mm Outerframe
AE1835GS/3 Reinforcing

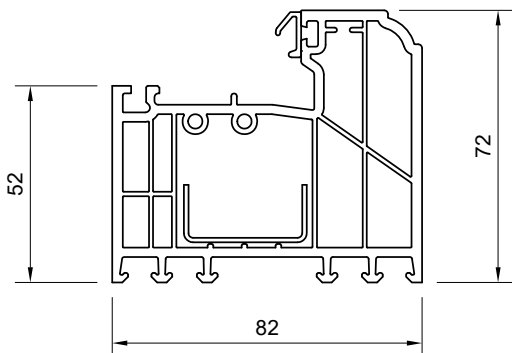

P90202 Storm 2 72mm Outerframe
S41101 Reinforcing

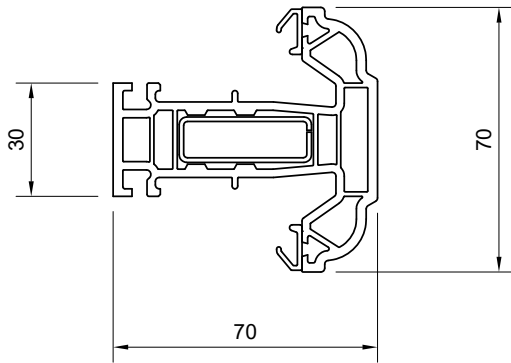

P10533 Storm 1 70mm Transom / Mullion
S00187 Reinforcing
Also Used As Flush French Casement Overlap

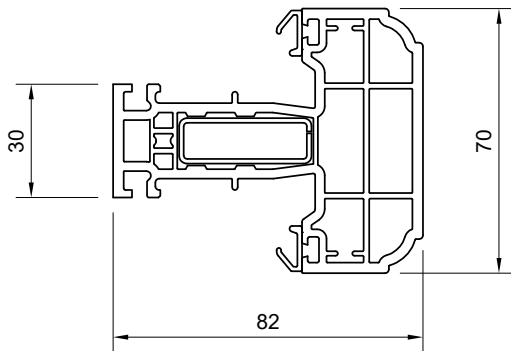

P90203 Storm 2 70mm Transom / Mullion
S00187 Reinforcing

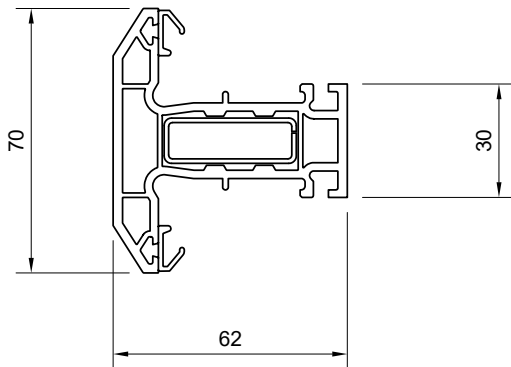

P62203 Storm 70mm Dummy Transom / Mullion
S00187 Reinforcing

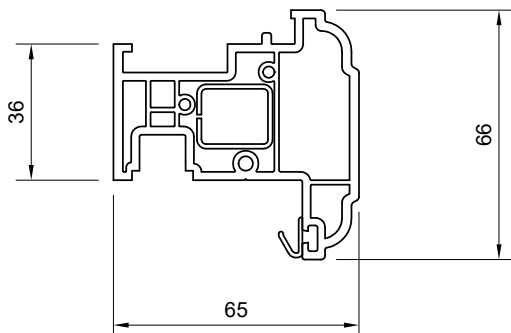

P10612 Storm French Casement Overlap
S41135 Reinforcing

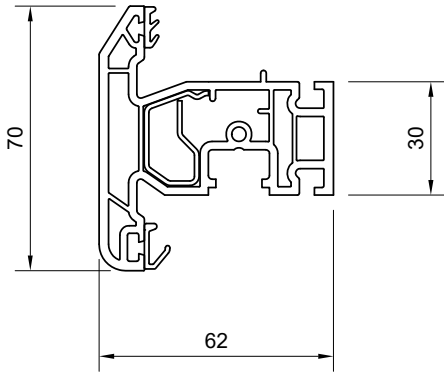

P90208 Storm Casement Sash
S00183 Reinforcing

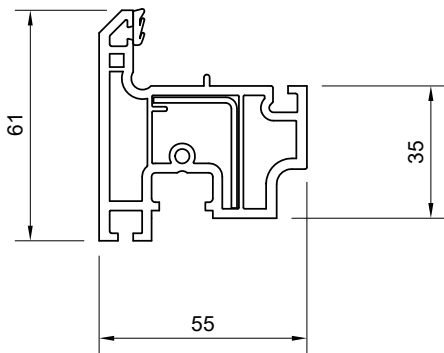

P10527 Flush Casement Sash
S00226 Reinforcing

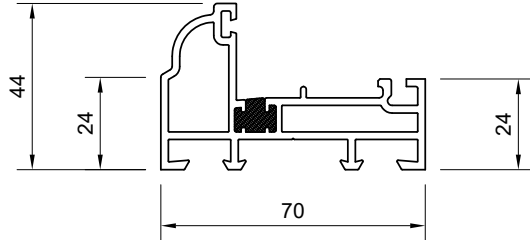

A00333 Storm 1 44mm Threshold
Note: Thermally Broken Aluminium

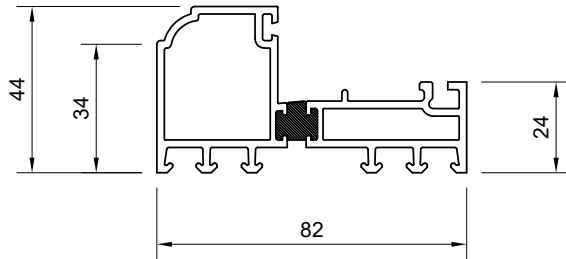

A00435 Storm 2 44mm Threshold
Note: Thermally Broken Aluminium

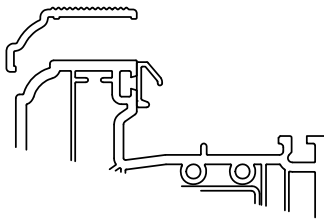

104475 Aluminium Kick Strip
Note: For Storm 2 56mm and 72mm
Thresholds

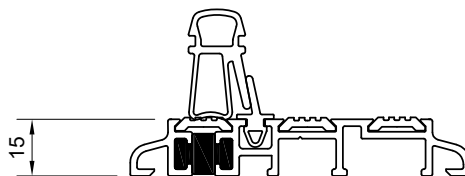

A00289 Part M Low Threshold with P01047
Threshold Inserts, G00086 Threshold Seal
and G00087 Sash Seal
Note: Thermally Broken Aluminium
Not suitable for use with French Doors or
Doors with Shootbolt Locking

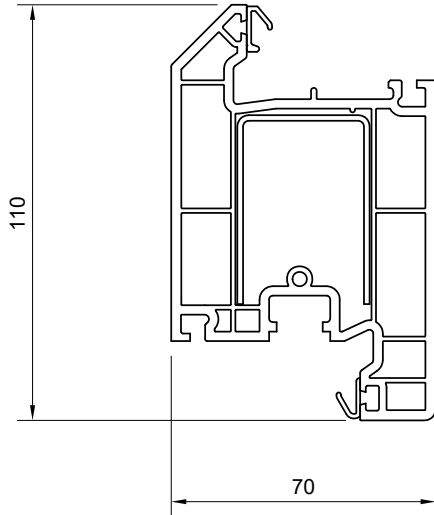

P10510 Open In Door Sash
S00162 / S00163 Reinforcing

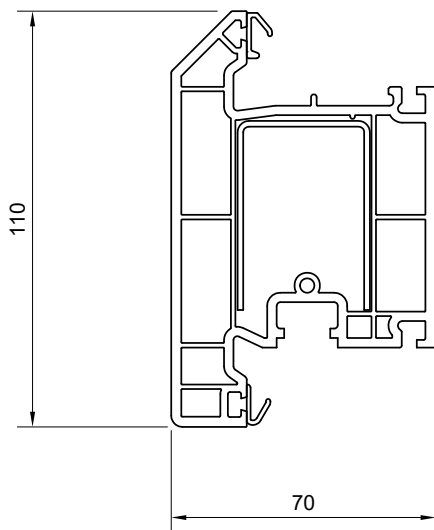

P10511 Open Out Door Sash
S00162 / S00163 Reinforcing

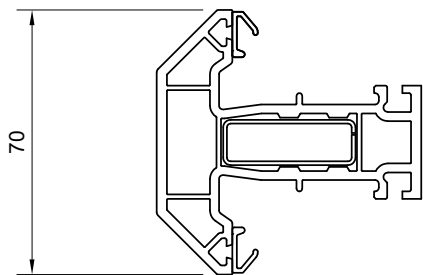

P10503 70mm Mullion / Transom
S00187 Reinforcing

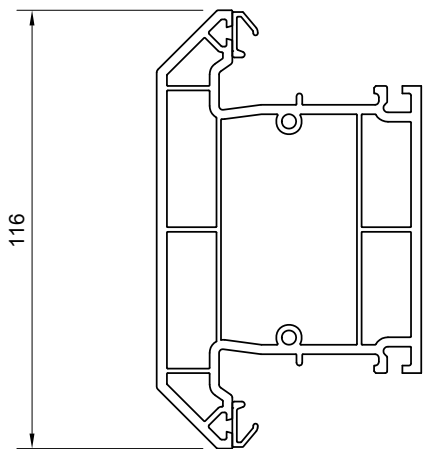

P10505 116mm Transom / Mullion / Midrail

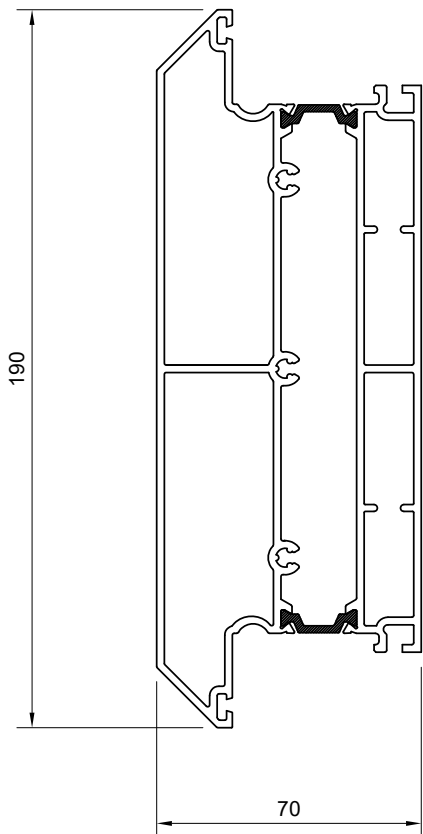

A00424 190mm Midrail
Note: Thermally Broken Aluminium

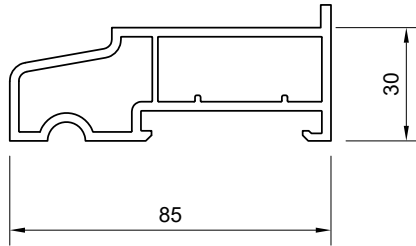

P90039 Storm 1 & 2 85mm Cill

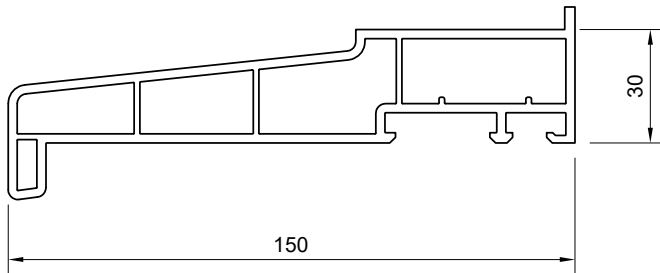

P90042 Storm 1 & 2 150mm Cill

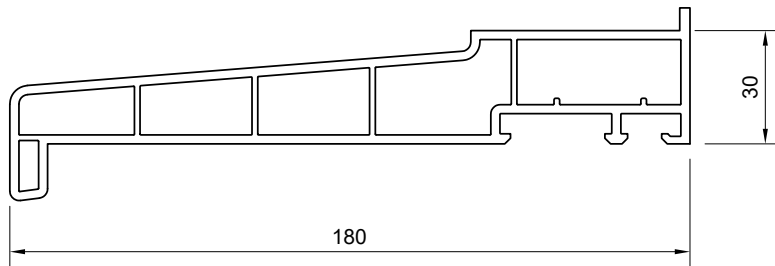

P90043 Storm 1 & 2 180mm Cill

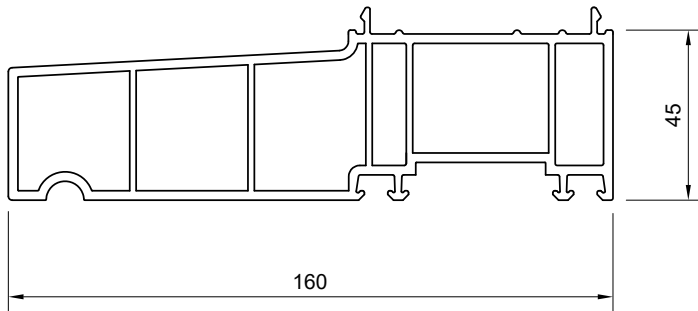

P90120 Storm 2 160mm Cill

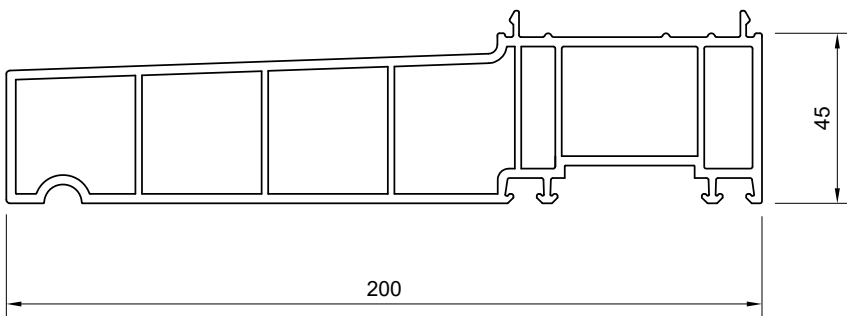

P90144 Storm 2 200mm Cill

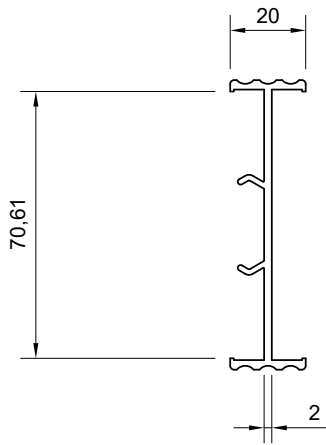

P10318 Storm 1 2mm Coupler

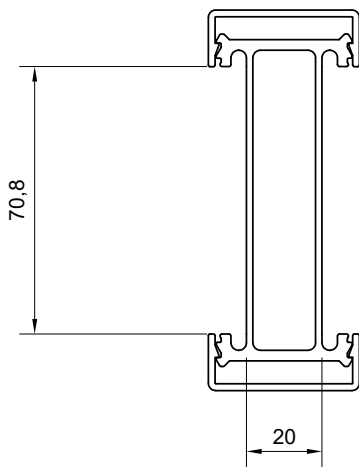

A00022 Storm 1 Heavy Duty Coupler - Aluminium
P10323 Plain Cover

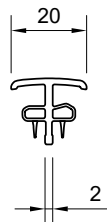

116 217 Storm 2 2mm Coupler
2 Required Per Frame Coupling (1 External, 1 Internal)

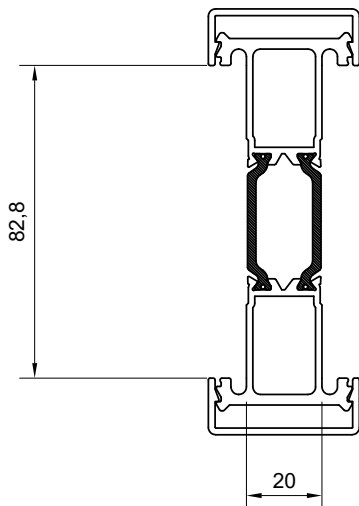

A00434 Storm 2 Heavy Duty Coupler
Thermally- Broken Aluminium
P10323 Plain Cover



P10431
28mm Glazing Bead - Storm



P10432
28mm Glazing Bead - Flush
32mm Glazing Bead - Storm



P10426
32mm Glazing Bead - Flush



P10191
20mm Georgian Bar
External - Putty Line - Storm



P10193
20mm Georgian Bar
External - Putty Line - Flush



P90123
20mm Georgian Bar
Internal - Ovolo - Storm & Flush



EV03
36mm Georgian Bar
External & Internal - Storm

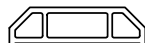

709021
36mm Georgian Bar
External & Internal - Flush

evolution[®]

© Evolution Manufacturing Limited