

LENGTH A

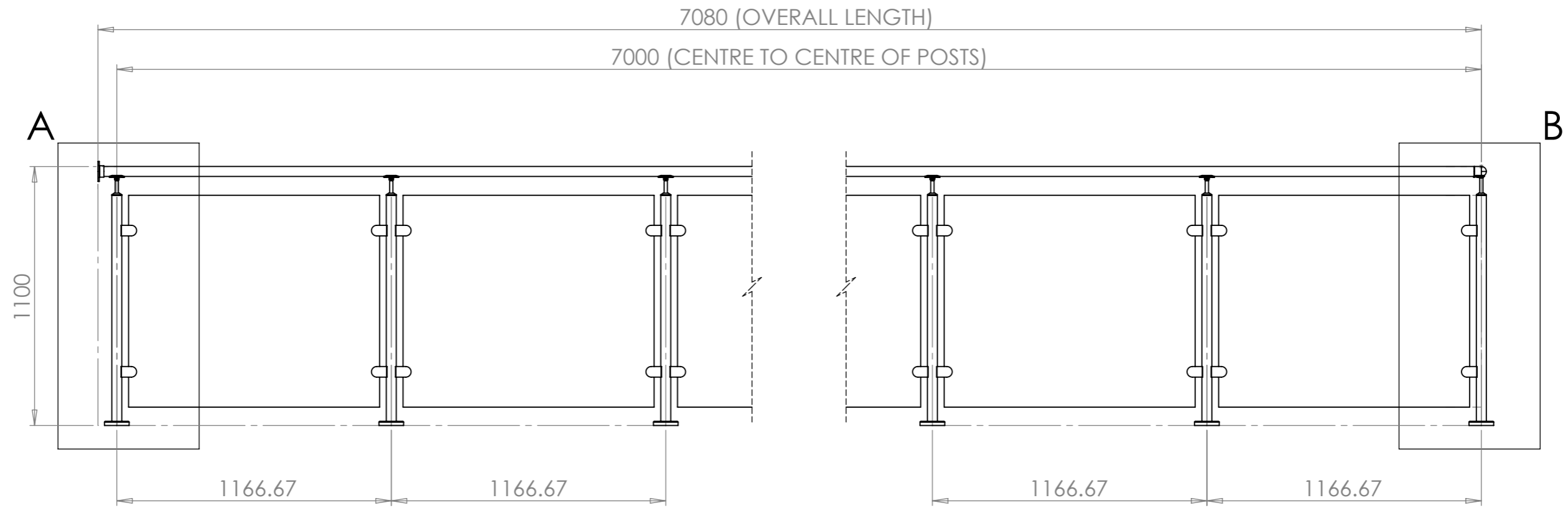

DETAIL A
SCALE 1 : 10

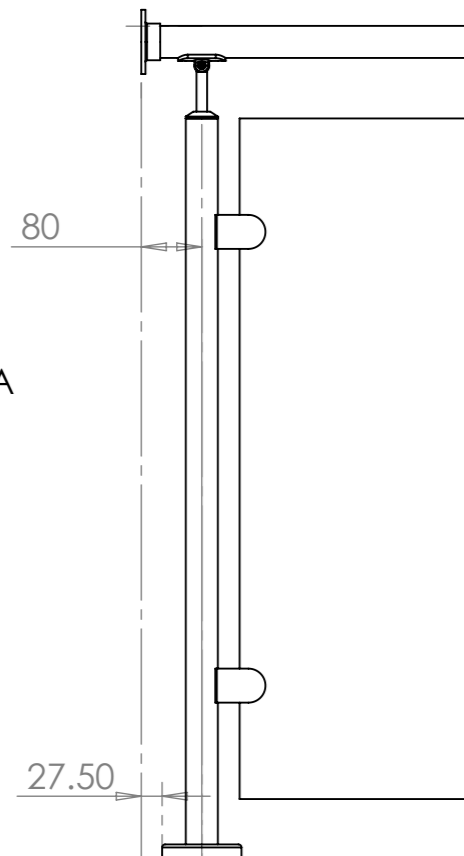

DETAIL B
SCALE 1 : 10

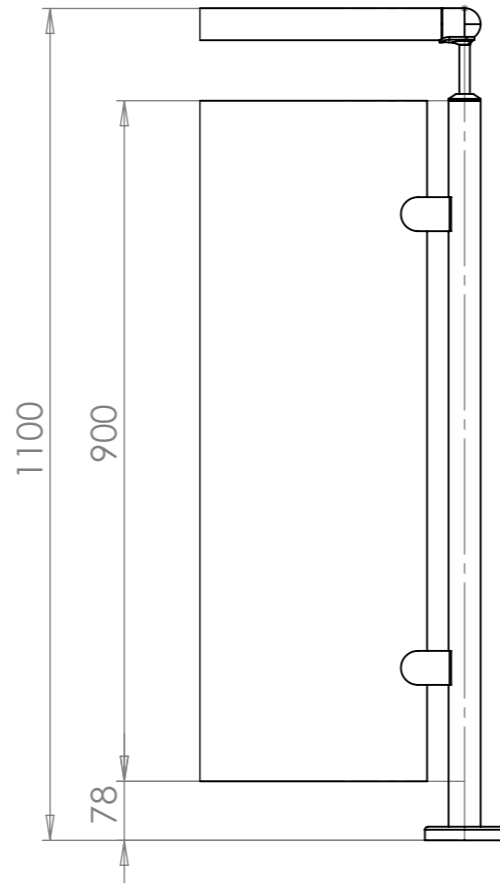

 REAL TIME DESIGN		NOTES: Customer Drawing Information	
		DESCRIPTION: Pre-Assembled Glass Clamp System	
UNLESS OTHERWISE SPECIFIED ALL DIMENSIONS ARE IN MILLIMETERS		QUOTE NO. LC-46867	
		CUSTOMER DETAILS: Kiely	
THIS DRAWING WAS CREATED AUTOMATICALLY		SCALE:1:20	SHEET 1 OF 6
MATERIAL: 304 SS TUBE SIZE: 42.40 GRIT SIZE: 320 Satin Polish WEIGHT: N/A Kg		DO NOT SCALE DRAWING	A3

LENGTH B

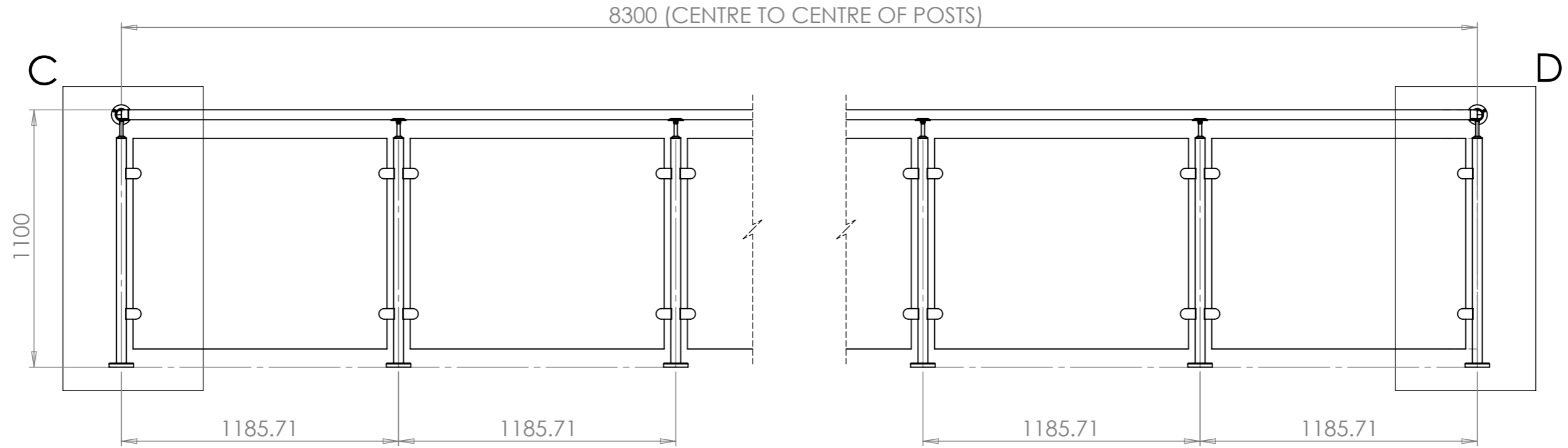

DETAIL C
SCALE 1 : 10

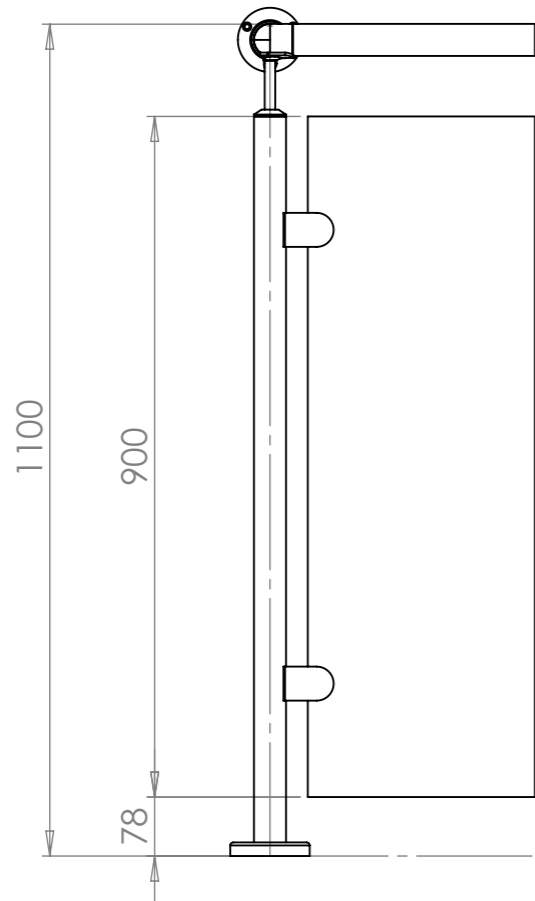

DETAIL D
SCALE 1 : 10

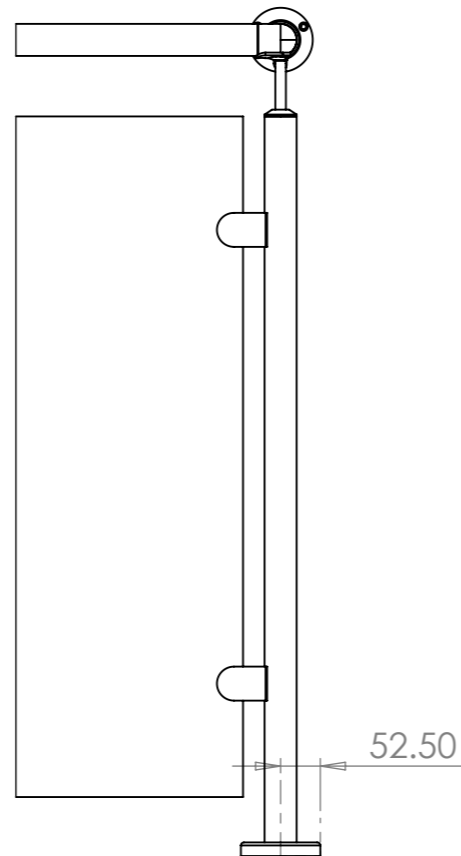

 REAL TIME DESIGN		NOTES:	
		Customer Drawing Information	
UNLESS OTHERWISE SPECIFIED ALL DIMENSIONS ARE IN MILLIMETERS		DESCRIPTION:	
		Pre-Assembled Glass Clamp System	
THIS DRAWING WAS CREATED AUTOMATICALLY		QUOTE NO.	
		LC-46867	
MATERIAL: 304 SS		CUSTOMER DETAILS:	
		Kiely	
TUBE SIZE: 42.4Ø		SCALE:1:20	DO NOT SCALE DRAWING
		SHEET 2 OF 6	
GRIT SIZE: 320 Satin Polish		A3	
		WEIGHT: N/A Kg	

LENGTH C

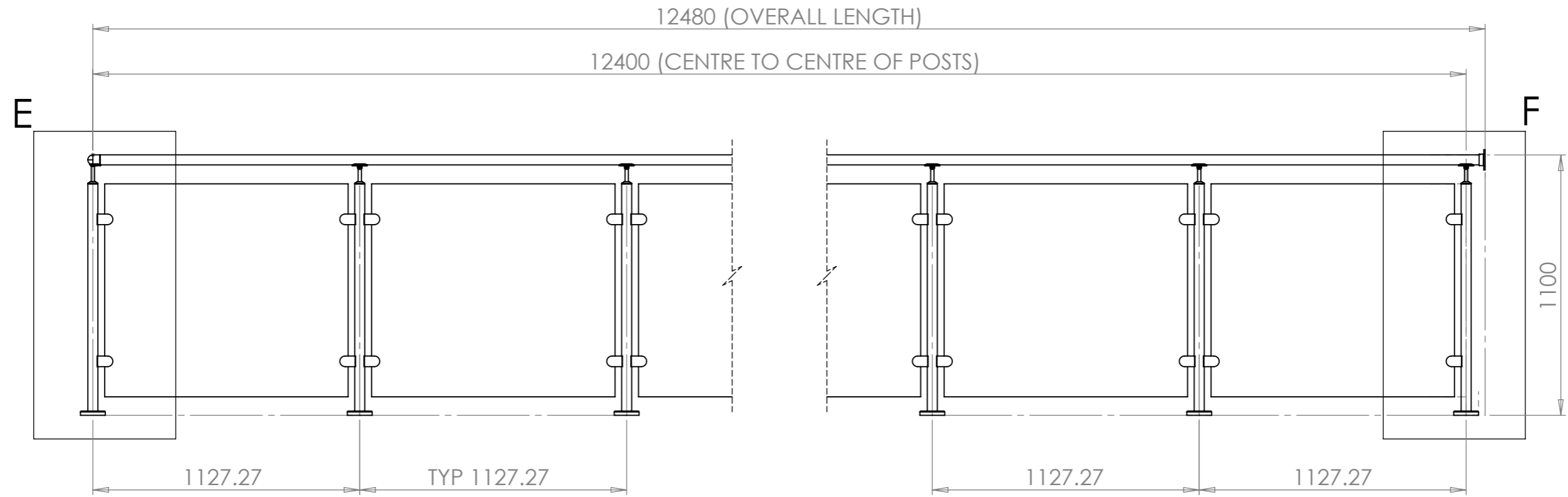

DETAIL E
SCALE 1 : 10

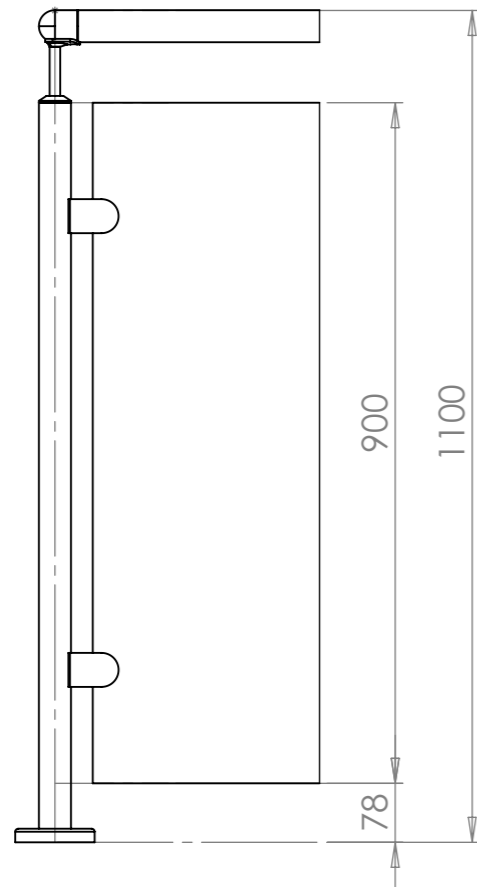

DETAIL F
SCALE 1 : 10

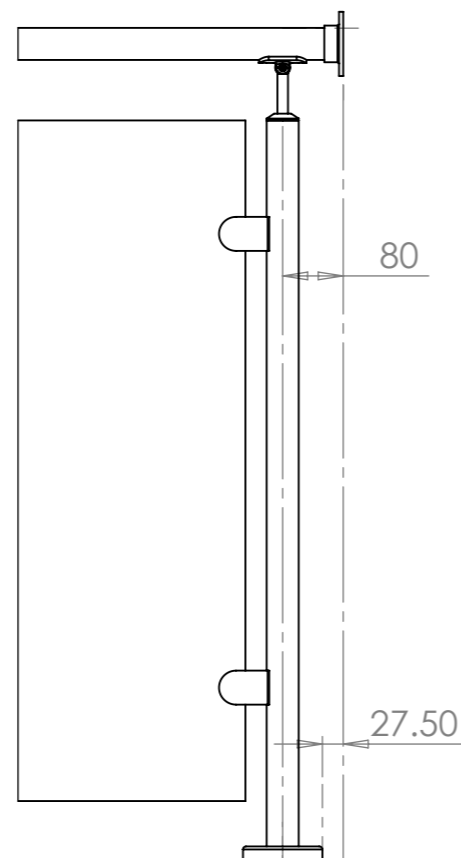

 REAL TIME DESIGN		NOTES: Customer Drawing Information		
		DESCRIPTION: Pre-Assembled Glass Clamp System		
UNLESS OTHERWISE SPECIFIED ALL DIMENSIONS ARE IN MILLIMETERS		QUOTE NO. LC-46867		
		CUSTOMER DETAILS: Kiely		
THIS DRAWING WAS CREATED AUTOMATICALLY		SCALE:1:20	DO NOT SCALE DRAWING	A3 SHEET 3 OF 6
MATERIAL: 304 SS		WEIGHT: N/A Kg		
TUBE SIZE: 42.4Ø		GRIT SIZE: 320 Satin Polish		

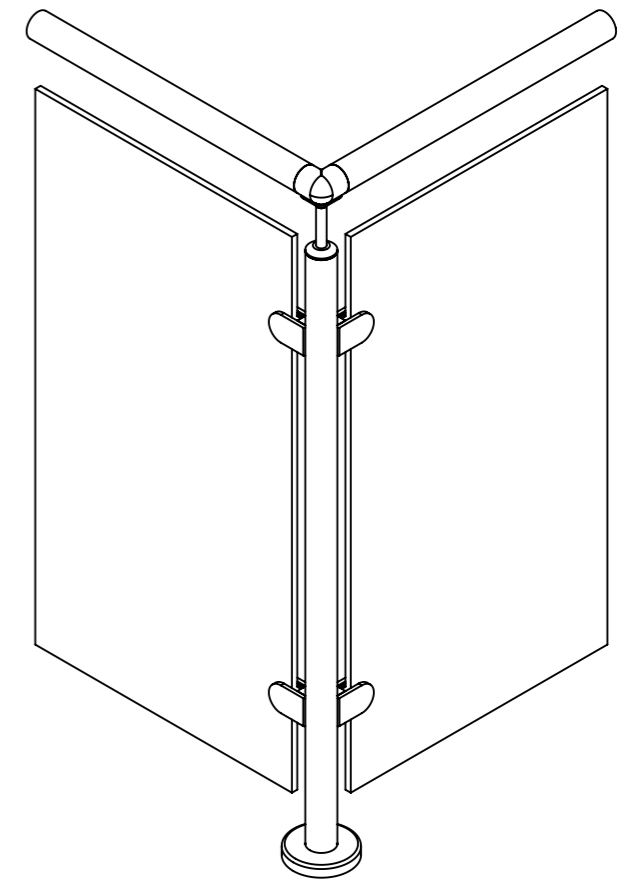
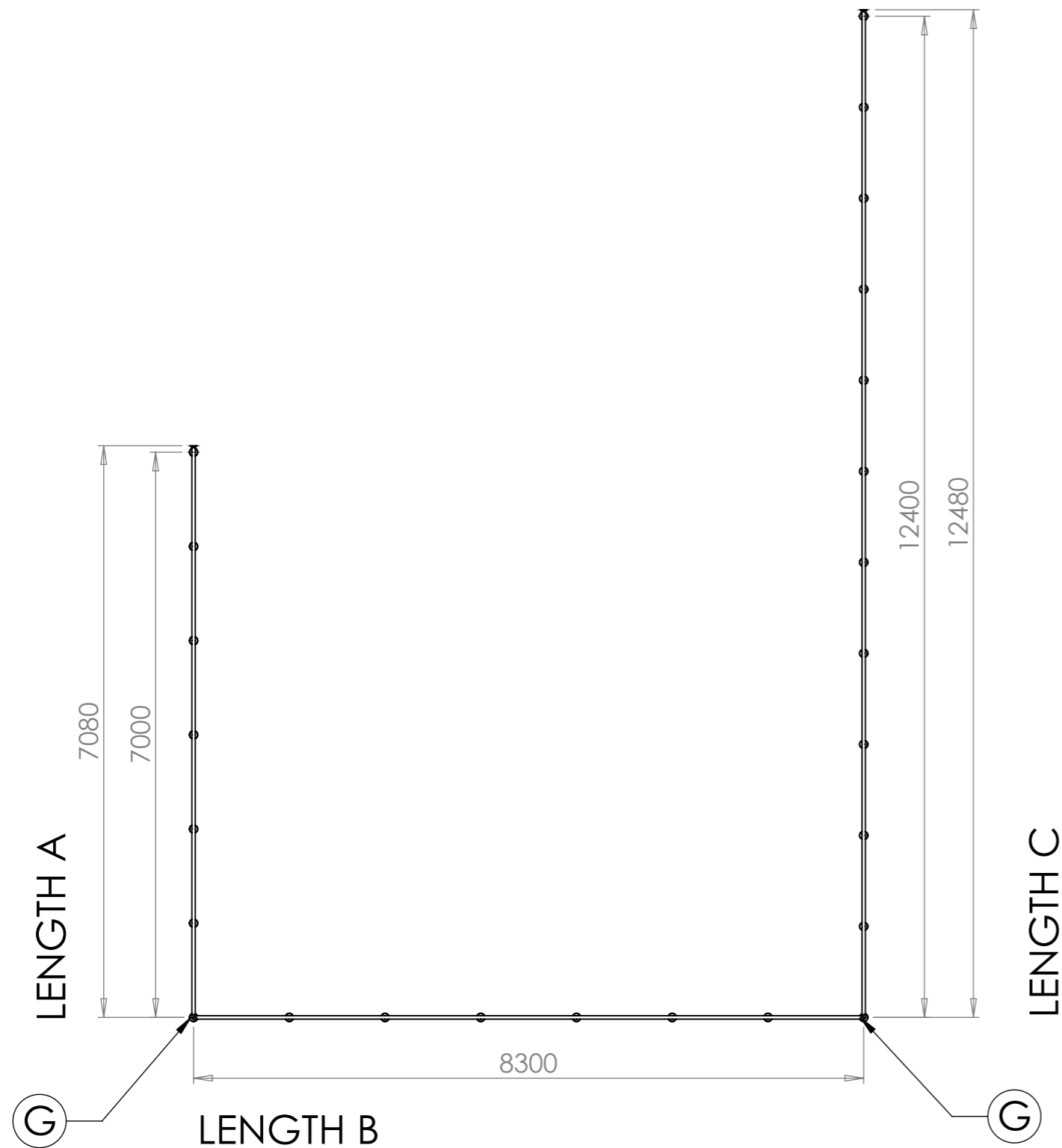

DETAIL G
SCALE 1 : 10

ITEM NO.	PART NUMBER	DESCRIPTION	QTY
1	1804791C	42.4Ø, 304 STAINLESS STEEL END POST	2
2	1804792C	42.4Ø, 304 STAINLESS STEEL MID POST	21
3	1804793C	42.4Ø, 304 STAINLESS STEEL CORNER POST	2
4	1804209C	42.4Ø, 304 STAINLESS STEEL ROUND WALL FLANGE	2
5	N/A	N/A	N/A
6	1804312CC	42.4Ø, 304 STAINLESS STEEL ADJUSTABLE SPIGOT	23
7	1804311CC	42.4Ø, 304 STAINLESS STEEL 90 DEGREE FIXED SPIGOT	2
8	1804701C	42.4Ø, 304 STAINLESS STEEL TUBE	27.74M
9	185510M	10MM CLEAR TOUGHENED GLASS	24

<p>REAL TIME DESIGN</p>		NOTES:	
		Customer Drawing Information	
<p>UNLESS OTHERWISE SPECIFIED ALL DIMENSIONS ARE IN MILLIMETERS</p>		DESCRIPTION:	
		Pre-Assembled Glass Clamp System	
<p>THIS DRAWING WAS CREATED AUTOMATICALLY</p>		QUOTE NO.	A3
		LC-46867	
<p>MATERIAL: 304 SS</p> <p>TUBE SIZE: 42.4Ø</p> <p>GRIT SIZE: 320 Satin Polish</p> <p>WEIGHT: N/A Kg</p>		CUSTOMER DETAILS:	
		Kiely	
		SCALE:1:20	SHEET 4 OF 6
		DO NOT SCALE DRAWING	

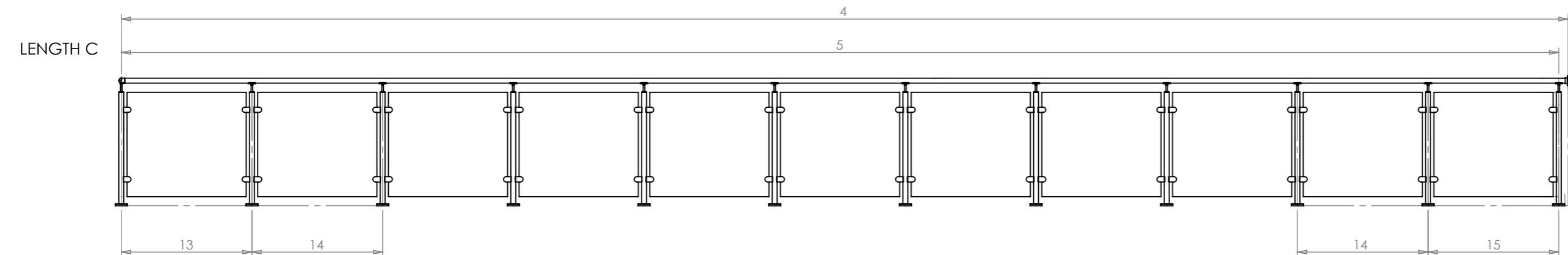
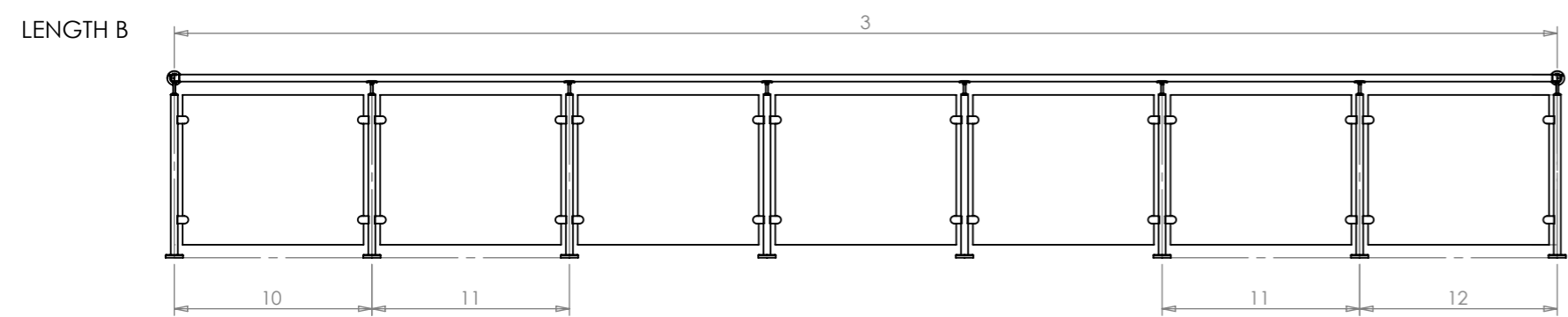
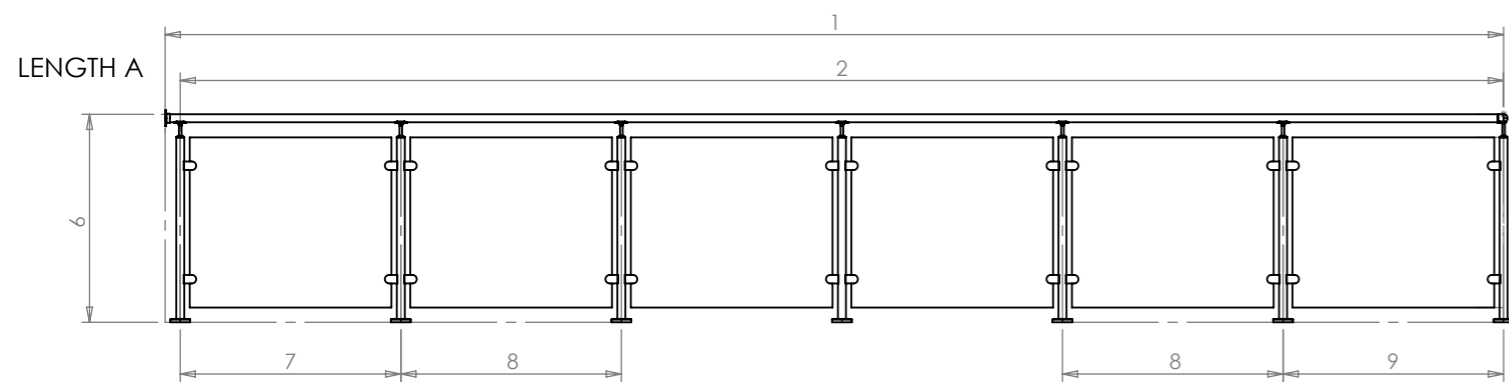

ITEM NO.	DESCRIPTION	LENGTH IN MM
1	OVERALL LENGTH (LENGTH A)	7080
2	START POST CENTRE TO END POST CENTRE (LENGTH A)	7000
3	POST CENTRE TO POST CENTRE (LENGTH B)	8300
4	OVERALL LENGTH (LENGTH C)	12480
5	START POST CENTRE TO END POST CENTRE (LENGTH C)	12400
6	OVERALL HEIGHT	1100
7	START PANEL POST CENTRES (LENGTH A)	1166.67
8	TYP POST CENTRES (LENGTH A)	1166.67
9	END PANEL POST CENTRES (LENGTH A)	1166.67
10	START PANEL POST CENTRES (LENGTH B)	1185.71
11	TYP POST CENTRES (LENGTH B)	1185.71
12	END PANEL POST CENTRES (LENGTH B)	1185.71
13	START PANEL POST CENTRES (LENGTH C)	1127.27
14	TYP POST CENTRES (LENGTH C)	1127.27
15	END PANEL POST CENTRES (LENGTH C)	1127.27

REAL TIME DESIGN

NOTES:
Customer Drawing Information

DESCRIPTION:
Pre-Assembled Glass Clamp System

QUOTE NO.
LC-46867

CUSTOMER DETAILS:
Kiely

UNLESS OTHERWISE SPECIFIED
ALL DIMENSIONS ARE IN MILLIMETERS

THIS DRAWING WAS CREATED AUTOMATICALLY

MATERIAL:
304 SS

TUBE SIZE:
42.4Ø

GRIT SIZE:
320 Satin Polish

WEIGHT: N/A Kg

SCALE: 1:20

DO NOT SCALE DRAWING

SHEET 5 OF 6

A3

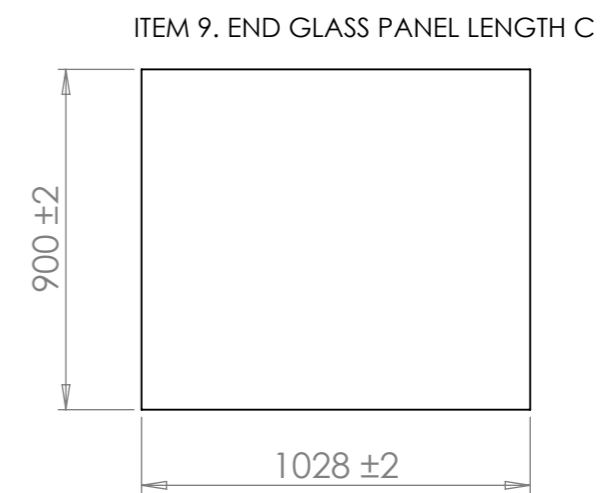
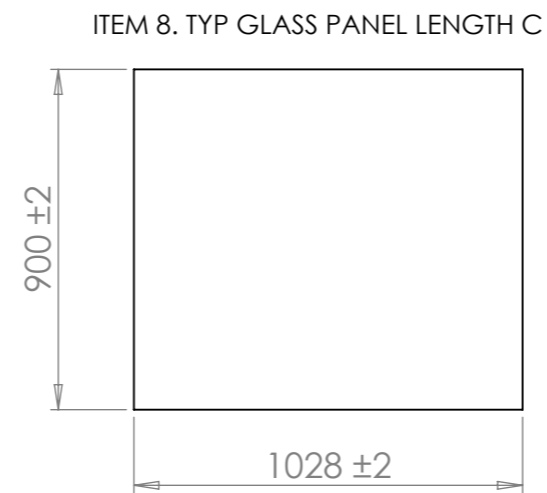
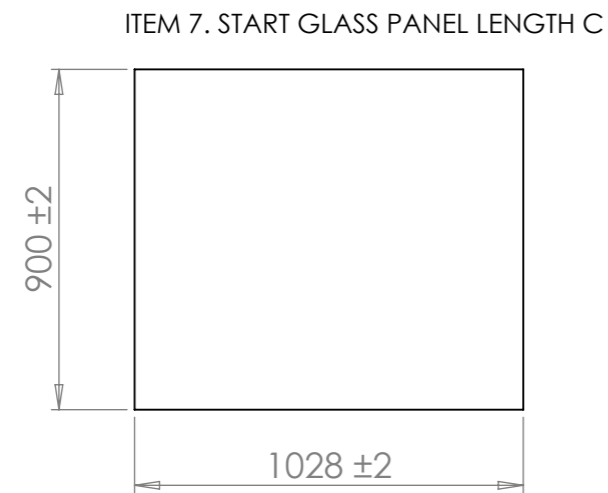
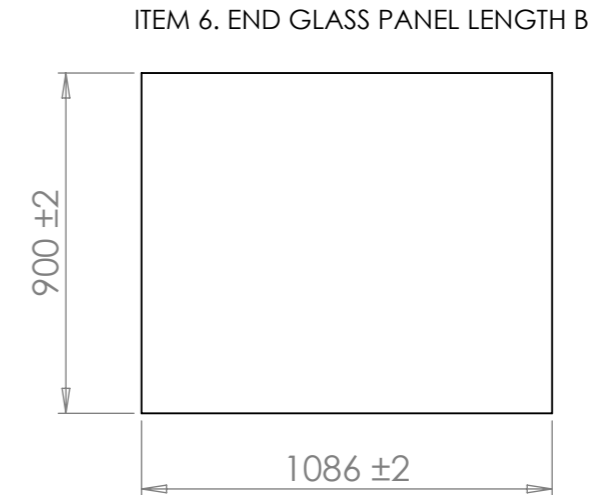
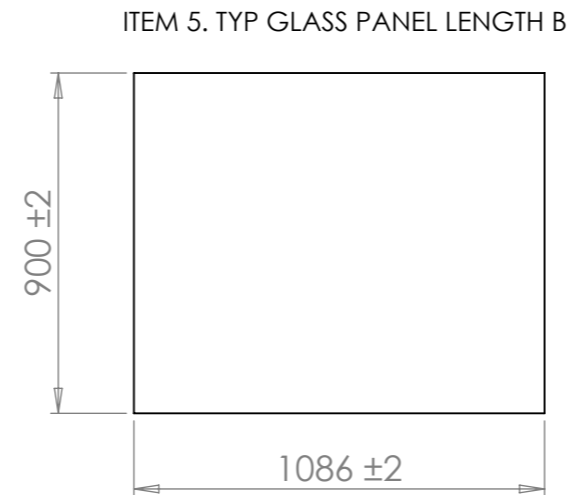
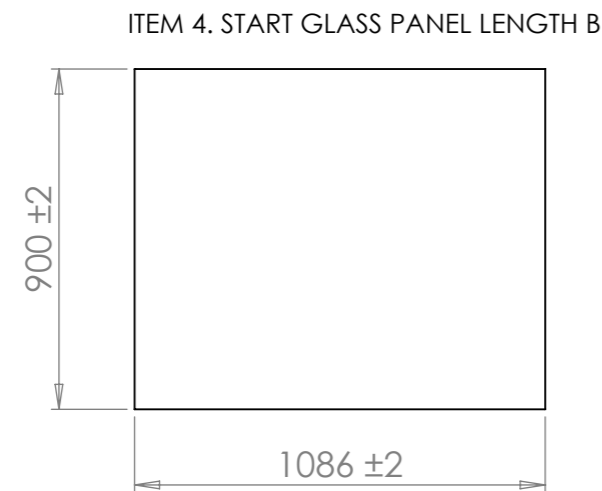
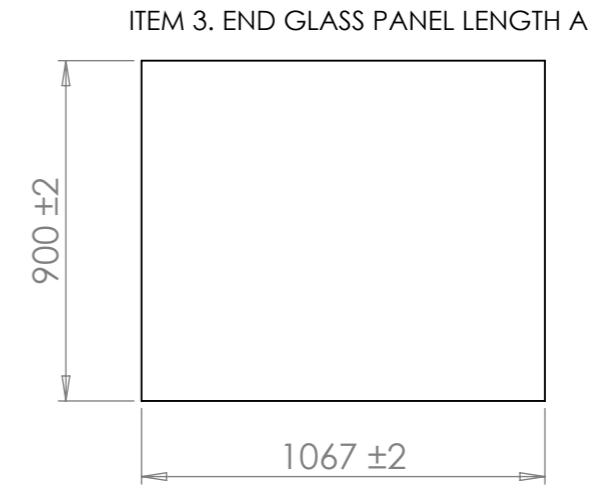
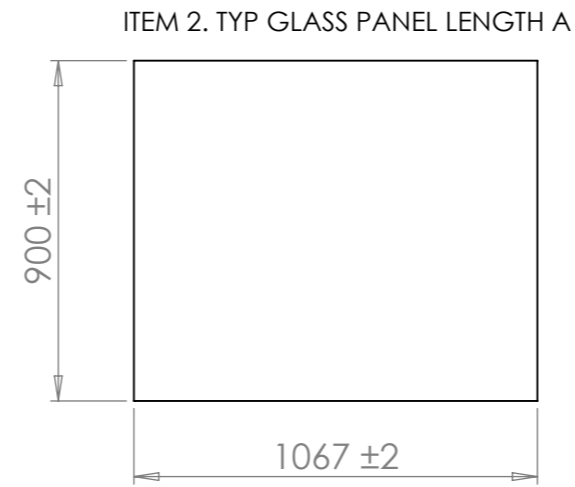
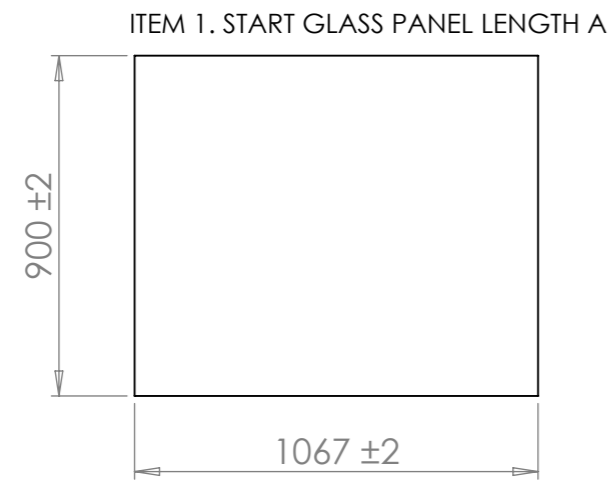

* DUBBED CORNERS & POLISHED EDGES

GLASS COMPLIES WITH BRITISH STANDARDS BS EN 12150

ITEM NO.	DESCRIPTION	THICKNESS IN MM	COLOUR/TYPE	QTY
1	START GLASS PANEL (LENGTH A)	10	CLEAR TOUGHENED	1
2	TYP GLASS PANEL (LENGTH A)	10	CLEAR TOUGHENED	4
3	END GLASS PANEL (LENGTH A)	10	CLEAR TOUGHENED	1
4	START GLASS PANEL (LENGTH B)	10	CLEAR TOUGHENED	1
5	TYP GLASS PANEL (LENGTH B)	10	CLEAR TOUGHENED	5
6	END GLASS PANEL (LENGTH B)	10	CLEAR TOUGHENED	1
7	START GLASS PANEL (LENGTH C)	10	CLEAR TOUGHENED	1
8	TYP GLASS PANEL (LENGTH C)	10	CLEAR TOUGHENED	9
9	END GLASS PANEL (LENGTH C)	10	CLEAR TOUGHENED	1



REAL TIME DESIGN

NOTES:
Customer Drawing Information

DESCRIPTION:
Pre-Assembled Glass Clamp System

QUOTE NO.
LC-46867

CUSTOMER DETAILS:
Kiely

UNLESS OTHERWISE SPECIFIED
ALL DIMENSIONS ARE IN MILLIMETERS

THIS DRAWING WAS CREATED AUTOMATICALLY

MATERIAL:
304 SS

TUBE SIZE:
42.4Ø

GRIT SIZE:
320 Satin Polish

WEIGHT: Kg

SCALE: 1:20 DO NOT SCALE DRAWING SHEET 6 OF 6

A3